

Sub-assemblies

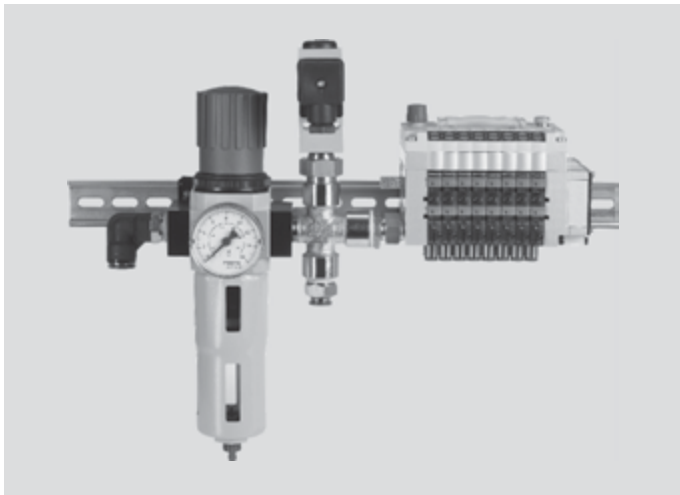

- Pneumatic and electrical components preassembled to create a function unit
- Can be combined from around 30,000 catalogue components
- Connections included
- For integration in machines

The Festo product portfolio includes around 30,000 individual components, which can be preassembled to create a sub-assembly based on their function. Accessories such as fittings and connections can also be assembled on the unit. The sub-assembly can thus be

installed directly in the system or in the higher-level system as a ready-to-install subsystem. A sub-assembly can be made up of a wide range of components. Typical combinations include:

- Cylinder/valve combinations
 - Components for compressed air preparation combined with valves
 - Valve manifolds
- Third-party components can be integrated and the sub-assembly can be mounted on a plate as required.

Upon completion, the entire unit undergoes a complete functional test. The sub-assembly is supplied ready-to-install.

Technical data

- Combination of various pneumatic and/or electrical components to create a single unit
- For a wide range of industrial applications
- Application-specific combination of components
- Optional accessories mounted on sub-assembly
- Use of the latest innovations and technologies

- Ready-to-install:
 - All steps from engineering through to assembly and right up to quality inspection are performed by Festo specialists.
- 100% tested, with test certificate
- Complete documentation

- Design conforms to:
 - EN 60204-1
 - ATEX zone 1 and 21 (pneumatic only), ATEX zone 2 and 22 (electric and electropneumatic)
 - UL-508A
- Implementation of safety functions

Ready-to-install – the benefits to you

Ordering
Just one order number for the entire solution.

Production & assembly
The entire production and assembly process, including wiring and connection, is taken care of for you. Connections to the system can be pre-installed on the sub-assembly if required.

Documentation
You receive detailed system documentation, which you can quickly and easily integrate into your overall documentation:

- Assembly drawing
- Parts list
- Circuit diagrams
- Operating instructions for components

Testing & test run
The sub-assembly is fully tested.

Interested in sub-assemblies?

Ask your Festo sales engineer, who will be happy to help.

Or visit your local website at www.festo.com,

where you will find further information on ready-to-install solutions.

Sub-assemblies

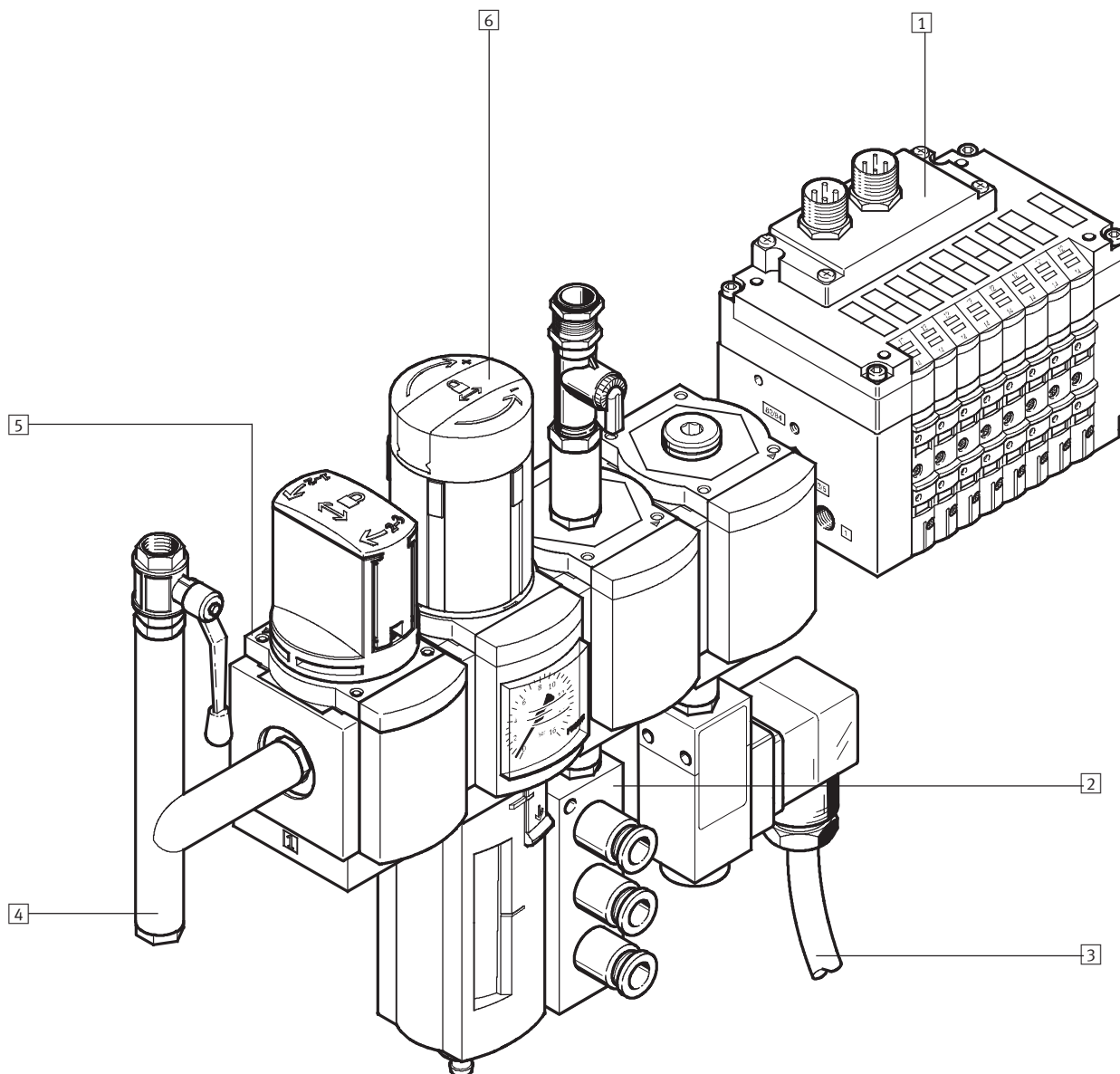

- 1 Valves and valve terminals
- 2 Other pneumatic components
 - Cylinders
 - Pressure regulators
 - Pressure gauges
 - Third-party components
 - Connections
 - Sensors
 - Servopneumatics
 - etc.

- 3 Tubing, wiring and piping
 - Number of wires
 - Cross section
 - Cable harness/individual cables
 - Cable inscription

- 4 Outputs
 - Pneumatic
 - Electrical
 - Multi-pin interfaces
- 5 Mounting options
 - For mounting in the system

- 6 Compressed air preparation
 - MS series
 - D series
 - Customised configuration of modules