

Solenoid coil VACS

FESTO

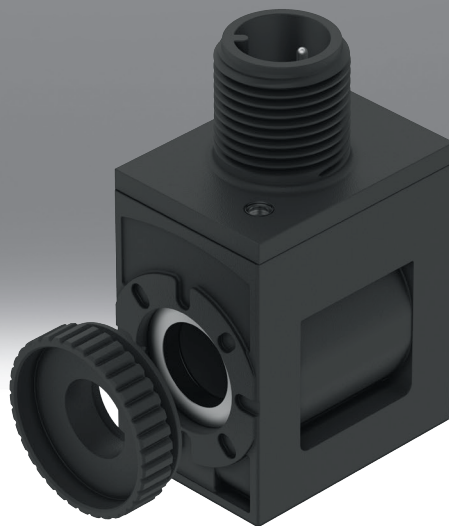

Type code

001	Series	
VACS	Solenoid coil VACS	
002	Solenoid coil type	
C	Solenoid coil width of 18 mm for armature tube of 8 mm	
003	Electrical connection	
C1	Plug pattern type C, to EN 175301-803	
E1	Plug pattern type C, industry standard	
R1	Individual connector M8, 4-pin	
R3	Single plug M12 A-coded, according to EN 61076-2-101	
R4	Single plug M12 A-coded, pin assignment according to DESINA	
R8	Individual connector M8, 3-pin	

004	Nominal operating voltage	
1	24 V DC	
1A	24 V AC/50-60 Hz	
3W	230 V AC/240 V AC/50-60 Hz	
5	12 V DC	
7	48 V DC	
7A	48 V AC/50-60 Hz	
16B	120 V AC/60 Hz and 110V AC/50-60 Hz	

005	Circuitry	
	None	
RA	Holding current reduction, analogue, with integrated protective circuit	

006	Display	
	None	
L	LED	

Datasheet

General technical data - Solenoid coils width 18 mm for Armature tube 8 mm, with electrical connection port pattern Form C, according to EN 175301-803



Electrical connection 1, connection type	Plugs
Electrical connection 1, connector system	Plug pattern type C to EN 175301-803
Electrical connection 1, number of connections/cores	3
Electrical connection 1, type of mounting	Central screw M2.5
Type of actuation	Electric
Conforms to standard	IEC 61010-1
Mounting position	optional
Type of mounting	Via knurled nut

Electrical data - Solenoid coils width 18 mm for Armature tube 8 mm, with electrical connection port pattern form C, according to EN 175301-803

Nominal operating voltage	24 V DC	12 V DC	48 V DC
Characteristic coil data	24 V DC: 2.6 W	12 V DC: 2.6 W	48 V DC: 2.4 W
Permissible voltage fluctuations	+/- 10%		
Duty cycle	100%		
Insulation material class	H		
Degree of protection	IP65		
Pollution degree	-		

Electrical data - Solenoid coils width 18 mm for Armature tube 8 mm, with electrical connection port pattern form C, according to EN 175301-803

Nominal operating voltage	24 V AC/50-60 Hz	230 V AC/240 V AC/50-60 Hz	48 V AC/50-60 Hz	120 V AC/60 Hz and 110V AC/50-60 Hz
Characteristic coil data	24 V AC: 50/60 Hz, pick-up power 2.5 VA, holding power 1.8 VA	230/240 V AC: 50/60 Hz, pick-up power 3.0 VA, holding power 2.3 VA	48 V AC: 50/60 Hz, pick-up power 2.5 VA, holding power 1.9 VA	110/120 V AC: 50/60 Hz, pick-up power 2.8 VA, holding power 1.9 VA
Permissible voltage fluctuations	+/- 10%			
Duty cycle	100%			
Insulation material class	H			
Degree of protection	IP65			
Pollution degree	-	2	-	2

Materials - Solenoid coils width 18 mm for Armature tube 8 mm, with electrical connection port pattern Form C, according to EN 175301-803

Material housing	PA, Steel
Material winding	Copper
Note on materials	RoHS-compliant
LABS (PWIS) conformity	VDMA24364-B1/B2-L

Datasheet

Operating and environmental conditions - Solenoid coils width 18 mm for Armature tube 8 mm, with electrical port pattern Form C, according to EN 175301-803

Nominal operating voltage	24 V DC	24 V AC/50-60 Hz	230 V AC/240 V AC/50-60 Hz	12 V DC	48 V DC	48 V AC/50-60 Hz	120 V AC/60 Hz and 110V AC/50-60 Hz
Ambient temperature	-10 ... 60°C						
Corrosion resistance class CRC ¹⁾	2 - Moderate corrosion stress						
Approval	c UL us - Recognized (OL)						
Certificate issuing authority	UL MH18122						

1) More information www.festo.com/x/topic/kbk

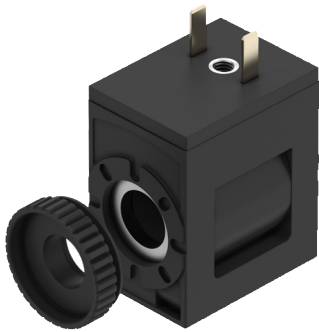
General technical data - Solenoid coils width 18 mm for Armature tube 8 mm, with electrical connection form C according to industry standard

Electrical connection 1, connection type	Plugs
Electrical connection 1, connector system	Plug pattern type C to industry standard, 9.4 mm
Electrical connection 1, number of connections/cores	2
Electrical connection 1, type of mounting	Central screw M3
Type of actuation	Electric
Conforms to standard	IEC 61010-1
Type of mounting	Via knurled nut
Mounting position	optional

Electrical data - Solenoid coils width 18 mm for Armature tube 8 mm, with electrical connection form C according to industry standard

Characteristic coil data	24 V DC: 2.6 W
Permissible voltage fluctuations	+/- 10%
Duty cycle	100%
Degree of protection	IP65
Insulation material class	H
Insulation material class of enamelled wire	H
Pollution degree	-

Material - Solenoid coils width 18 mm for Armature tube 8 mm, with electrical connection form C according to industry standard

Material solenoid coil	Copper, Steel, Thermoplastic
Material housing	PA, Steel
Material winding	Copper
Note on materials	RoHS-compliant
LABS (PWIS) conformity	VDMA24364-B1/B2-L

Datasheet

Operating and environmental conditions - Solenoid coils width 18 mm for Armature tube 8 mm, with electrical connection form C according to industry standard

Ambient temperature	-20 ... 60°C
Media temperature	-20 ... 60°C
Restrictions for environmental and media temperature	-20 - 50°C, with block mounting
Corrosion resistance class CRC ¹⁾	2 - Moderate corrosion stress
CE mark (see declaration of conformity) ²⁾	–
UKCA marking (see declaration of conformity) ³⁾	–
Approval	c UL us - Recognized (OL)
Certificate issuing authority	UL MH18122
Impact energy value	IK06

1) More information www.festo.com/x/topic/kbk

2) More information www.festo.com/catalogue/... Support/Downloads.

3) More information www.festo.com/catalogue/... Support/Downloads.

General technical data - Solenoid coils width 18 mm for Armature tube 8 mm, with electrical connection single plug M8, 4-pin



Electrical connection 1, connection type	Plugs
Electrical connection 1, connector system	M8x1, A-coded, to EN 61076-2-104
Electrical connection 1, number of connections/cores	4
Electrical connection 1, type of mounting	Screw-type lock
Type of actuation	Electric
Conforms to standard	IEC 61010-1; ISO 20401
Signal status display	LED
Mounting position	optional
Type of mounting	Via knurled nut

Electrical data - Solenoid coils width 18 mm for Armature tube 8 mm, with electrical connection single plug M8, 4-pin

Characteristic coil data	24 V DC: 2.8 W	24VDC: NS1,2:HS3.3
Permissible voltage fluctuations	+/- 10%	
Nominal pick-up current per solenoid coil	–	138 mA up to 70 ms
Nominal current with current reduction	–	50 mA after 70 ms
Duty cycle	100%	
Insulation material class	H	
Insulation material class of enamelled wire	H	
Degree of protection	IP65	

Datasheet

Materials - Solenoid coils width 18 mm for Armature tube 8 mm, with electrical connection single plug M8, 4-pin

Material housing	PA, Steel
Material solenoid coil	Copper, Steel, Thermoplastic
Material winding	Copper
Note on materials	RoHS-compliant
LABS (PWIS) conformity	VDMA24364-B1/B2-L

Operating and environmental conditions - Solenoid coils width 18 mm for Armature tube 8 mm, with electrical connection single plug M8, 4-pin

Characteristic coil data	24 V DC: 2.8 W	24VDC: NS1,2: HS3.3
Ambient temperature	-20 ... 60°C	
Media temperature	-20 ... 60°C	
Restrictions for environmental and media temperature	-20 - 50°C, with block mounting	-
Corrosion resistance class CRC ¹⁾	2 - Moderate corrosion stress	
Approval	c UL us - Recognized (OL)	
Certificate issuing authority	UL MH18122	
Impact energy value	IK06	

1) More information www.festo.com/x/topic/kbk

General technical data - Solenoid coils width 18 mm for Armature tube 8 mm, with electrical connection single plug M12, to EN 61076-2-101

Characteristic coil data	24 V DC: 2.8 W	24 V DC: low-current phase 0.36 W, high-current phase 2.6 W	24VDC: NS1,2: HS3.3
Electrical connection 1, connection type	Plugs	-	Plugs
Electrical connection 1, connector system	M12x1, A-coded to EN 61076-2-101	-	M12x1, A-coded to EN 61076-2-101
Electrical connection 1, number of connections/cores	2	-	2
Electrical connection 1, type of mounting	Screw-type lock	-	Screw-type lock
Type of actuation	Electric	-	Electric
Conforms to standard	IEC 61010-1, ISO 20401	-	IEC 61010-1, ISO 20401
Signal status display	LED		
Mounting position	optional		
Type of mounting	Via knurled nut		

Datasheet

Electrical data - Solenoid coils width 18 mm for Armature tube 8 mm, with electrical connection single plug M12, to EN 61076-2-101

Characteristic coil data	24 V DC: 2.8 W	24 V DC: low-current phase 0.36 W, high-current phase 2.6 W	24VDC:NS1,2:HS3.3
Permissible voltage fluctuations	+/- 10%		
Nominal pick-up current per solenoid coil	–	108 mA till 80 ms	138 mA up to 70 ms
Nominal current with current reduction	–	15 mA after 80 ms	50 mA after 70 ms
Duty cycle	100%		
Max. switching frequency	–	5	–
Insulation material class	H	–	H
Insulation material class of enamelled wire	H		
Max. cable length	–	30 m	
Degree of protection	IP65		

Material - Solenoid coils width 18 mm for Armature tube 8 mm, with electrical connection single plug M12, to EN 61076-2-101

Material housing	PA, Steel		
Material solenoid coil	Copper, Steel, Thermoplastic		
Material winding	Copper		
Note on materials	RoHS-compliant		
LABS (PWIS) conformity	VDMA24364-B1/B2-L		

Operating and environmental conditions - Solenoid coils width 18 mm for Armature tube 8 mm, with electrical connection single plug M12, according to EN 61076-2-101

Characteristic coil data	24 V DC: 2.8 W	24 V DC: low-current phase 0.36 W, high-current phase 2.6 W	24VDC:NS1,2:HS3.3
Ambient temperature	-20 ... 60°C	-10 ... 60°C	-20 ... 60°C
Media temperature	-20 ... 60°C	–	-20 ... 60°C
Restrictions for environmental and media temperature	-20 - 50°C, with block mounting	–	
Corrosion resistance class CRC ¹⁾	2 - Moderate corrosion stress		
CE mark (see declaration of conformity) ²⁾	–	To EU EMC Directive	To EU EMC Directive In accordance with EU RoHS Directive
Approval	c UL us - Recognized (OL)	RCM trademark	c UL us - Recognized (OL)
Certificate issuing authority	UL MH18122	–	UL MH18122
Impact energy value	IK06	–	IK06

1) More information www.festo.com/x/topic/kbk2) For information about the area of use, see the EC declaration of conformity at: www.festo.com/catalogue/... -> Support/Downloads.

If the devices are subject to usage restrictions in residential, commercial or light industrial environments, further measures for reducing the emitted interference may be necessary.

Datasheet

General technical data - Solenoid coils width 18 mm for Armature tube 8 mm, with electrical connection M12, assignment according to DESINA



Electrical connection 1, connection type	Plugs
Electrical connection 1, connector system	M12x1, A-coded to EN 61076-2-101
Electrical connection 1, number of connections/cores	4
Electrical connection 1, type of mounting	Screw-type lock
Type of actuation	Electric
Conforms to standard	DESINA, IEC 61010-1
Signal status display	LED
Mounting position	optional
Type of mounting	Via knurled nut

Electrical data - Solenoid coils width 18 mm for Armature tube 8 mm, with electrical connection M12, assignment according to DESINA

Characteristic coil data	24 V DC: 2.8 W	24VDC: NS1,2: HS3.3
Permissible voltage fluctuations	+/- 10%	
Nominal pick-up current per solenoid coil	–	138 mA up to 70 ms
Nominal current with current reduction	–	50 mA after 70 ms
Duty cycle	100%	
Insulation material class	H	
Insulation material class of enamelled wire	H	
Degree of protection	IP65	

Materials - Solenoid coils width 18 mm for Armature tube 8 mm, with electrical connection M12, assignment according to DESINA

Material housing	PA, Steel
Material solenoid coil	Copper, Steel, Thermoplastic
Material winding	Copper
Note on materials	RoHS-compliant
LABS (PWIS) conformity	VDMA24364-B1/B2-L

Datasheet

Operating and environmental conditions - Solenoid coils width 18 mm for Armature tube 8 mm, with electrical connection M12, assignment according to DESI-NA

Characteristic coil data	24 V DC: 2.8 W	24VDC: NS1,2: HS3.3
Ambient temperature	-20 ... 60°C	
Media temperature	-20 ... 60°C	
Restrictions for environmental and media temperature	-20 - 50°C, with block mounting	-
Corrosion resistance class CRC ¹⁾	2 - Moderate corrosion stress	
Approval	c UL us - Recognized (OL)	
Certificate issuing authority	UL MH18122	
Impact energy value	IK06	

1) More information www.festo.com/x/topic/kbk**General technical data - Solenoid coils width 18 mm for Armature tube 8 mm, with electrical connection M8, 3-pole**

Electrical connection 1, connection type	Plugs	
Electrical connection 1, connector system	M8x1, A-coded, to EN 61076-2-104	
Electrical connection 1, number of connections/cores	3	
Electrical connection 1, type of mounting	Screw-type lock	
Type of actuation	Electric	
Conforms to standard	IEC 61010-1, ISO 20401	
Signal status display	LED	
Mounting position	optional	
Type of mounting	Via knurled nut	

Electrical data - Solenoid coils width 18 mm for Armature tube 8 mm, with electrical connection M8, 3-pole

Characteristic coil data	24 V DC: 2.8 W	24VDC: NS1,2: HS3.3
Permissible voltage fluctuations	+/- 10%	
Nominal pick-up current per solenoid coil	-	138 mA up to 70 ms
Nominal current with current reduction	-	50 mA after 70 ms
Duty cycle	100%	
Insulation material class	H	
Insulation material class of enamelled wire	H	
Degree of protection	IP65	

Datasheet

Materials - Solenoid coils width 18 mm for Armature tube 8 mm, with electrical connection M8, 3-pole

Material housing	PA, Steel
Material solenoid coil	Copper, Steel, Thermoplastic
Material winding	Copper
Note on materials	RoHS-compliant
LABS (PWIS) conformity	VDMA24364-B1/B2-L

Operating and environmental conditions - Solenoid coils width 18 mm for Armature tube 8 mm, with electrical connection M8, 3-pole

Characteristic coil data	24 V DC: 2.8 W	24VDC:NS1,2:HS3.3
Ambient temperature	-20 ... 60°C	
Media temperature	-20 ... 60°C	
Restrictions for environmental and media temperature	-20 - 50°C, with block mounting	-
Corrosion resistance class CRC	2 - Moderate corrosion stress	
Approval	c UL us - Recognized (OL)	
Certificate issuing authority	UL MH18122	
Impact energy value	IK06	

Dimensions

Dimensions – Solenoid coils width 18 mm for Armature tube 8 mm, with electrical connection port pattern form C, according to EN 175301-803

Download CAD data www.festo.com

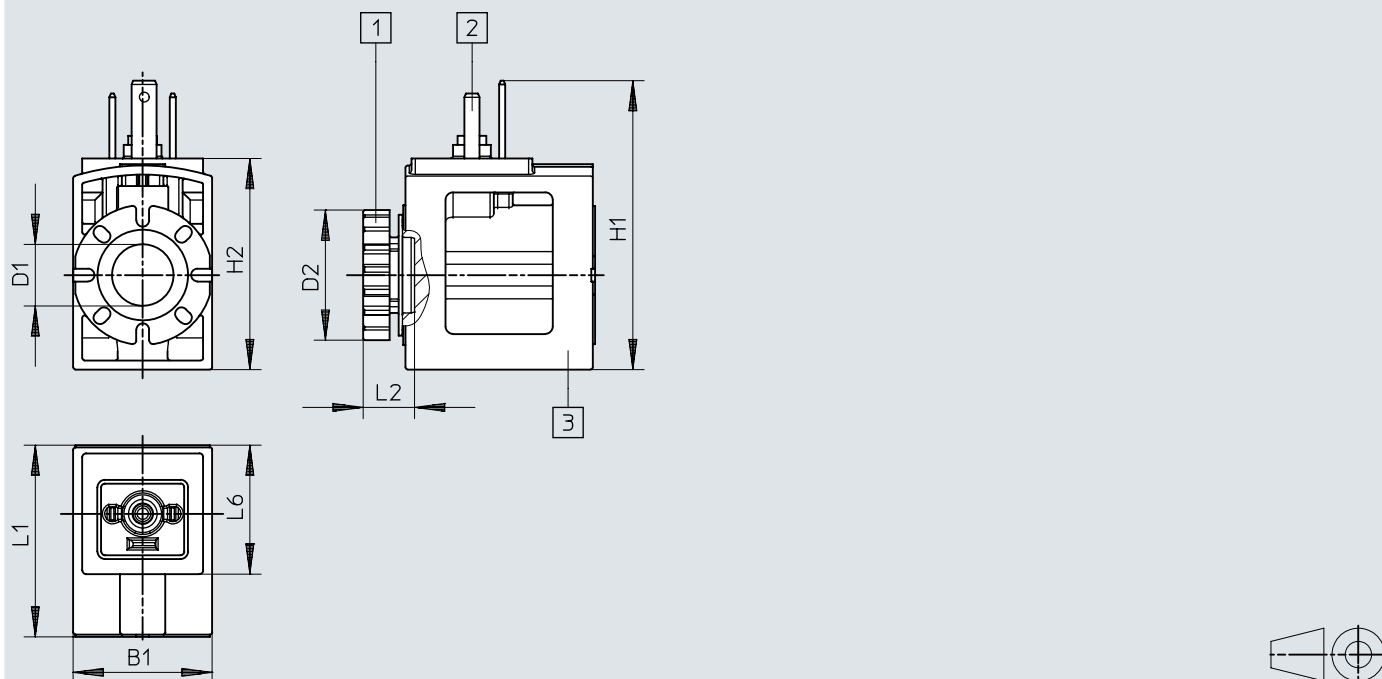

- [1] Knurled nut (seal set for solenoid coil)
 [2] Plug pattern according to EN 175301-803 Type C
 [3] Solenoid coil (can be rotated in increments of 45° on the armature, can be pushed on in any direction)

	B1	D1 ∅	D2 ∅	H1	H2	L1	L2	L6
VACS-C-C1-...	18,4	8,2	17,2	38,3	28	25,4	6,8	17,4

Dimensions

Dimensions – Solenoid coils width 18 mm for Armature tube 8 mm, with electrical connection Port pattern Form C according to industry standard

Download CAD data www.festo.com

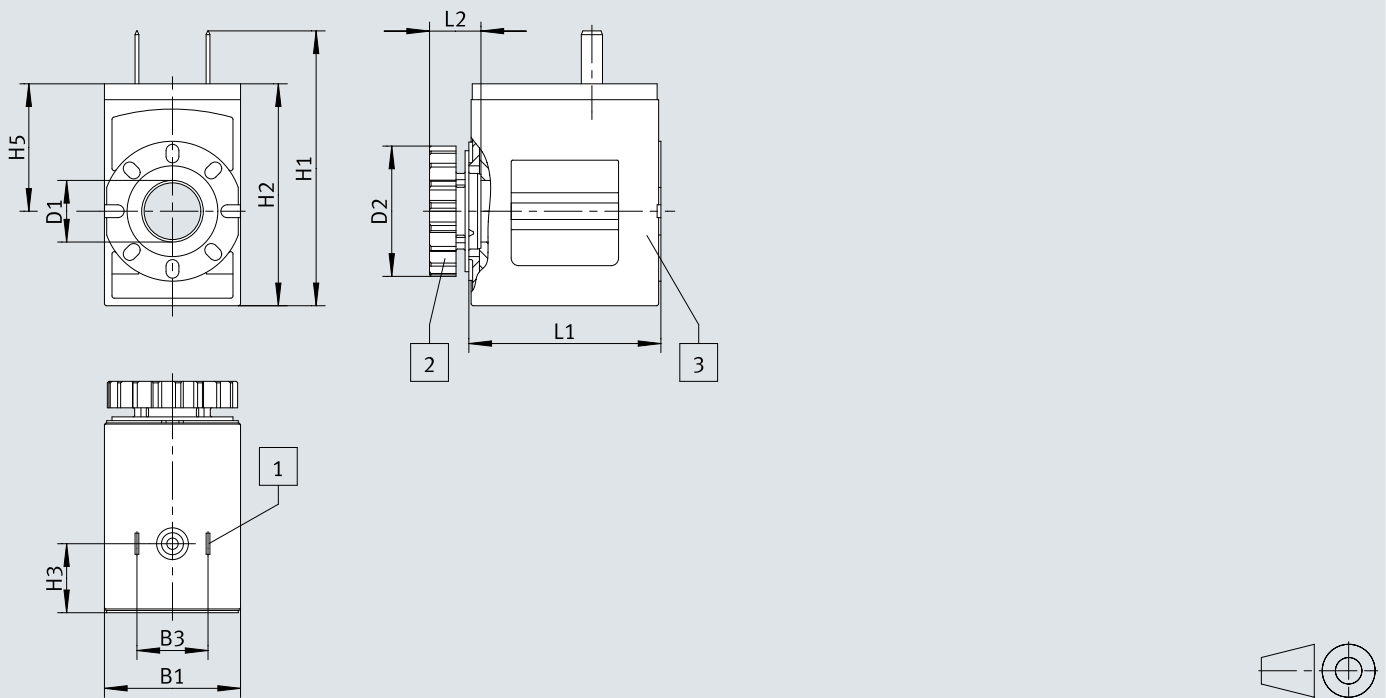

- [1] Knurled nut (seal set for solenoid coil)
- [2] Plug pattern according to EN 175301-803 Type C
- [3] Solenoid coil (can be rotated in increments of 45° on the armature, can be pushed on in any direction)

	B1	B3	D1 ∅	D2 ∅	H1	H2	H3	H5	L1	L2
VACS-C-E1-1	18	9,4	8,2	17,2	36,4	29,4	9,1	16,9	25,4	6,8

Dimensions

Dimensions – Solenoid coils width 18 mm for Armature tube 8 mm, with electrical connection single plug M8, 4-pin

Download CAD data www.festo.com

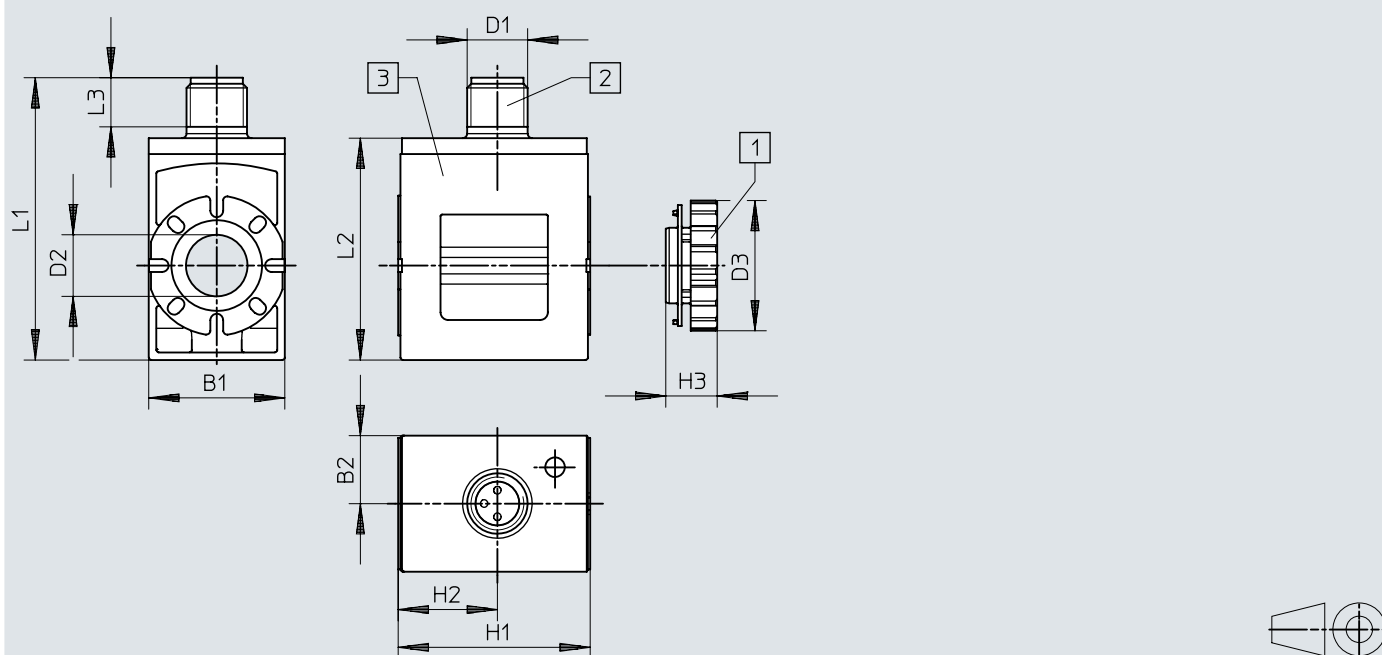

[1] Knurled nut

[2] Plug, M8x1, A-coded to EN 61076-2-104

[3] Solenoid coil (can be rotated in increments of 45° on the armature, can be pushed on in any direction)

	B1	B2	D1	D2 ∅	D3 ∅	H1	H2	H3	L1	L2
VACS-C-R1-...	18	9	M8	8,2	17,2	25,4	13,1	6,8	37,4	29,4

Dimensions

Dimensions – Solenoid coils width 18 mm for Armature tube 8 mm, with electrical connection single plug M12, to EN 61076-2-101

Download CAD data www.festo.com

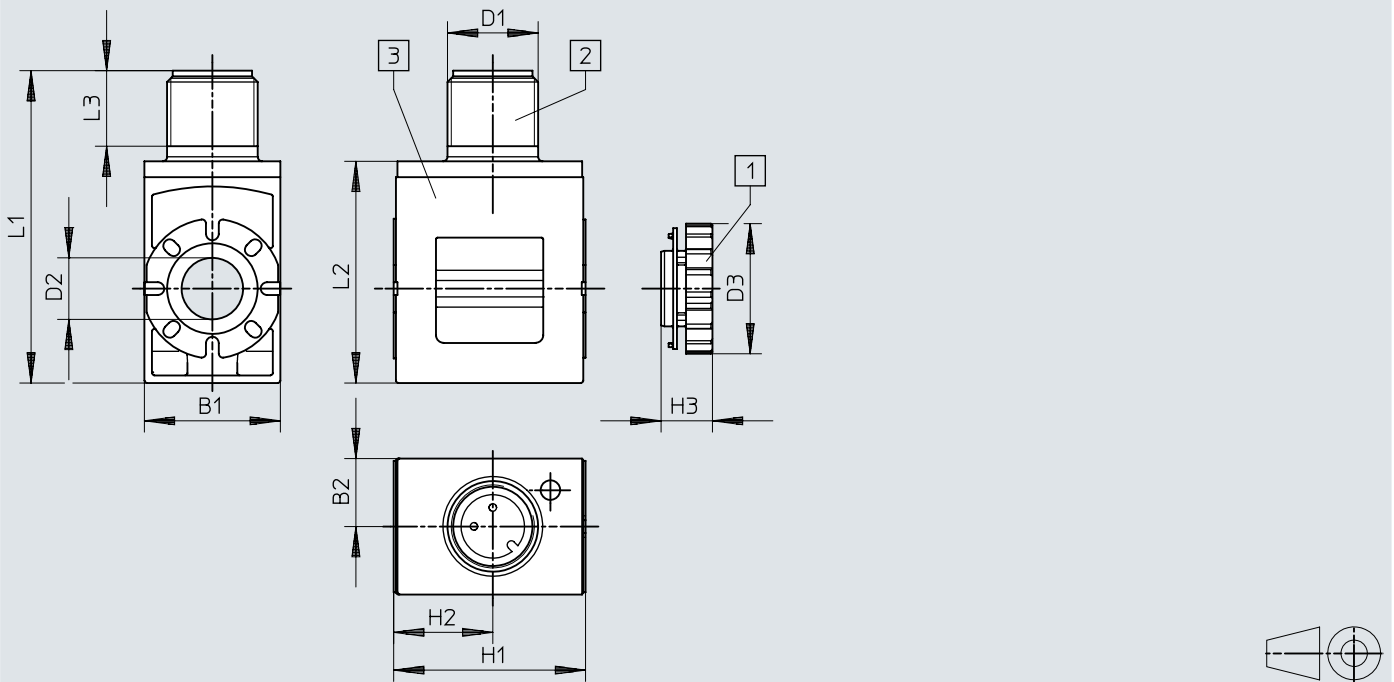

- [1] Knurled nut
- [2] Plug, M12x1, A-coded to EN 61076-2-101
- [3] Solenoid coil (can be rotated in increments of 45° on the armature, can be pushed on in any direction)

	B1	B2	D1	D2 ∅	D3 ∅	H1	H2	H3	L1	L2	L3
VACS-C-R3-...	18	9	M12	8,2	17,2	25,4	13,1	6,8	41,4	29,4	10

Dimensions

Dimensions – Solenoid coils width 18 mm for Armature tube 8 mm, with electrical connection M12, assignment according to DESINA

Download CAD data www.festo.com

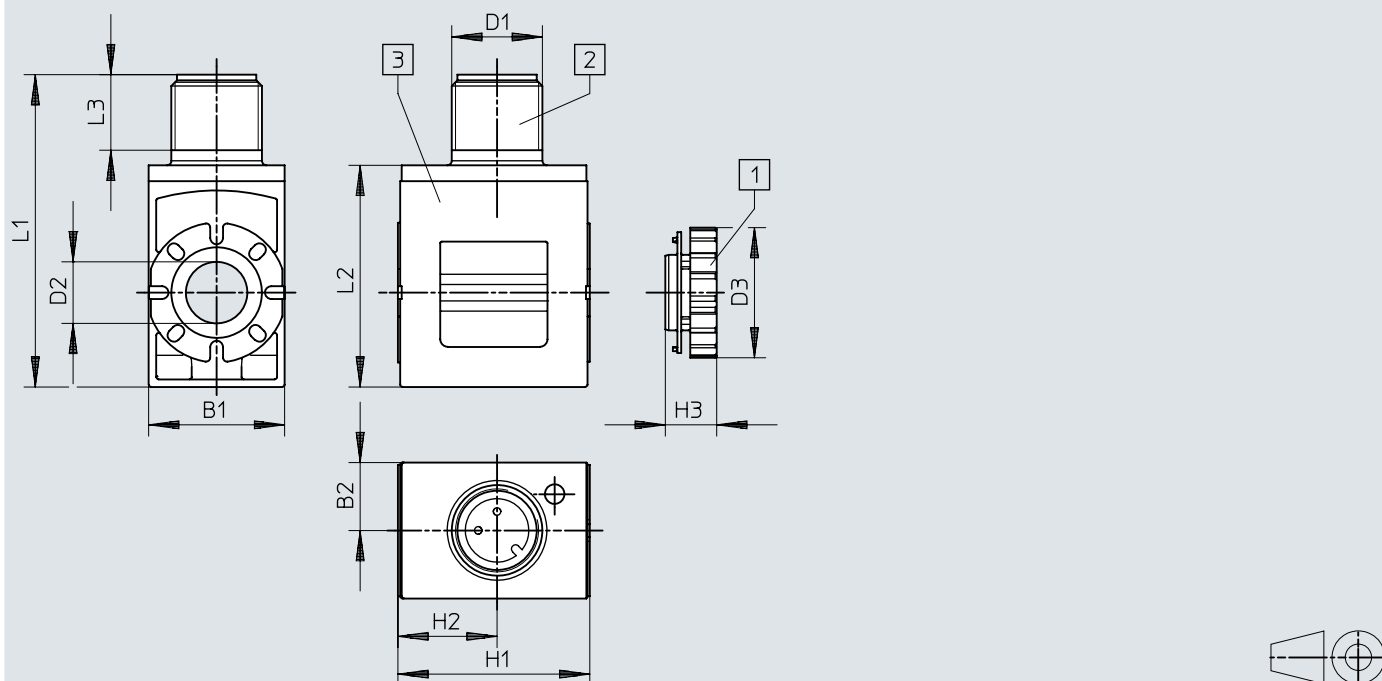

[1] Knurled nut

[2] Plug, M12x1, A-coded to EN 61076-2-101

[3] Solenoid coil (can be rotated in increments of 45° on the armature, can be pushed on in any direction)

	B1	B2	D1	D2 ∅	D3 ∅	H1	H2	H3	L1	L2	L3
VACS-C-R4-...	18	9	M12	8,2	17,2	25,4	13,1	6,8	41,4	29,4	10

Dimensions

Dimensions – Solenoid coils width 18 mm for Armature tube 8 mm, with electrical connection M8, 3-pole

Download CAD data www.festo.com

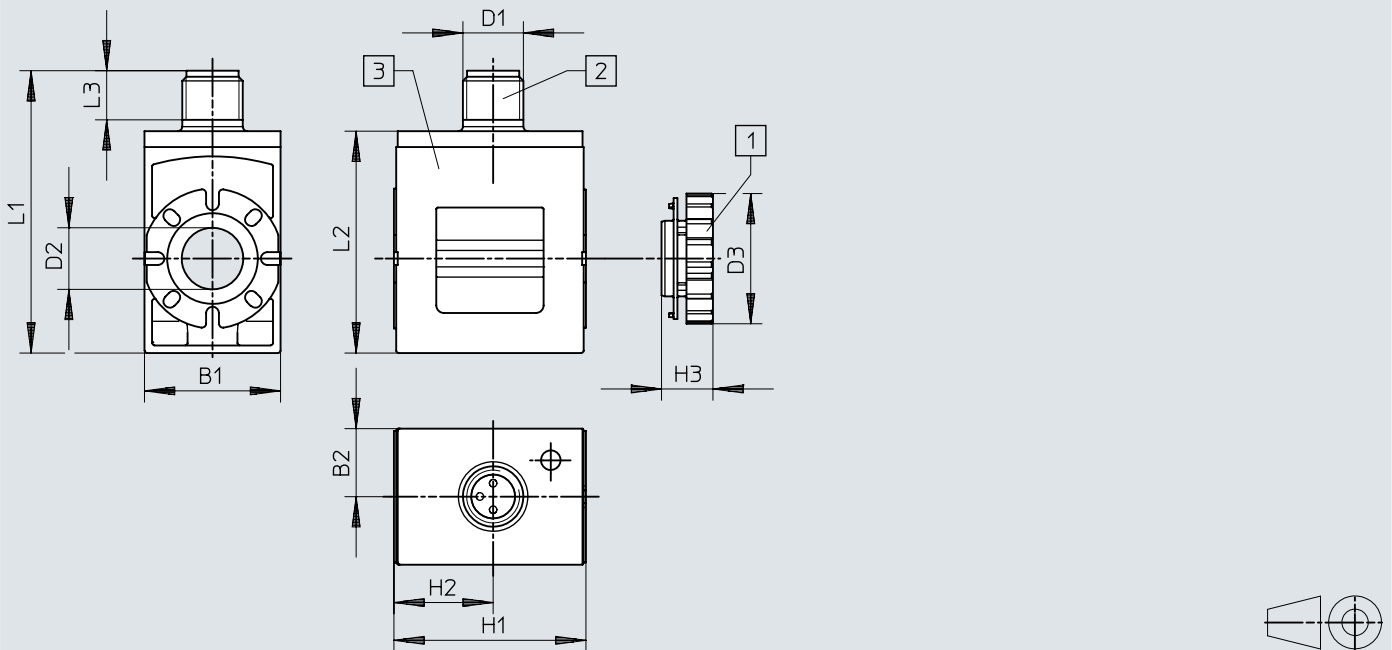

- [1] Knurled nut
- [2] Plug, M8x1, A-coded to EN 61076-2-104
- [3] Solenoid coil (can be rotated in increments of 45° on the armature, can be pushed on in any direction)

	B1	B2	D1	D2 ∅	D3 ∅	H1	H2	H3	L1	L2	L3
VACS-C-R8-...	18	9	M8	8,2	17,2	25,4	13,1	6,8	37,4	29,4	6,5

Ordering data

Solenoid coils width 18 mm for Armature tube 8 mm, with electrical connection port pattern form C, according to EN 175301-803					
Electrical connection 1, connection type	Electrical connection 1, connector system	Nominal operating voltage	Product weight	Part no.	Type
Plugs	Plug pattern type C to EN 175301-803	24 V DC	35.2 g	8025330	VACS-C-C1-1
		24 V AC/50-60 Hz	35.8 g	8025335	VACS-C-C1-1A
		230 V AC/240 V AC/50-60 Hz	34.6 g	8025338	VACS-C-C1-3W
		12 V DC	36.1 g	8025331	VACS-C-C1-5
		48 V DC	37.1 g	8025336	VACS-C-C1-7
		48 V AC/50-60 Hz	35.6 g	8025337	VACS-C-C1-7A
		120 V AC/60 Hz and 110V AC/50-60 Hz	34.8 g	8025334	VACS-C-C1-16B

Solenoid coils width 18 mm for Armature tube 8 mm, with electrical connection Port pattern Form C according to industry standard					
Electrical connection 1, connection type	Electrical connection 1, connector system	Nominal operating voltage	Product weight	Part no.	Type
Plugs	Plug pattern type C to industry standard, 9.4 mm	24 V DC	32 g	8153948	VACS-C-E1-1

Solenoid coils width 18 mm for Armature tube 8 mm, with electrical connection single plug M8, 4-pin					
Electrical connection 1, connection type	Electrical connection 1, connector system	Characteristic coil data	Product weight	Part no.	Type
Plugs	M8x1, A-coded, to EN 61076-2-104	24 V DC: 2.8 W	32.5 g	8135906	VACS-C-R1-1L
		24VDC:NS1,2:HS3.3		8135910	VACS-C-R1-1RAL

Solenoid coils width 18 mm for Armature tube 8 mm, with electrical connection single plug M12, to EN 61076-2-101					
Electrical connection 1, connection type	Electrical connection 1, connector system	Characteristic coil data	Product weight	Part no.	Type
Plugs	M12x1, A-coded to EN 61076-2-101	24 V DC: low-current phase 0.36 W, high-current phase 2.6 W	33 g	8135822	VACS-C-R3-1RL
		24 V DC: 2.8 W		8135907	VACS-C-R3-1L
		24VDC:NS1,2:HS3.3		8194567	VACS-C-R3-1RAL

Solenoid coils width 18 mm for Armature tube 8 mm, with electrical connection M12, assignment according to DESINA					
Electrical connection 1, connection type	Electrical connection 1, connector system	Characteristic coil data	Product weight	Part no.	Type
Plugs	M12x1, A-coded to EN 61076-2-101	24 V DC: 2.8 W	33 g	8135908	VACS-C-R4-1L
		24VDC:NS1,2:HS3.3		8135911	VACS-C-R4-1RAL

Solenoid coils width 18 mm for Armature tube 8 mm, with electrical connection M8, 3-pole					
Electrical connection 1, connection type	Electrical connection 1, connector system	Characteristic coil data	Product weight	Part no.	Type
Plugs	M8x1, A-coded, to EN 61076-2-104	24 V DC: 2.8 W	32.5 g	8135905	VACS-C-R8-1L
		24VDC:NS1,2:HS3.3		8135909	VACS-C-R8-1RAL

Accessories

Seal-SET for Solenoid coils with electrical port pattern form C, to achieve protection class IP67

	Product weight	Part no.	Type
	6 g	2643771	VAMC-B10-C-B-S8