

Imprint

Version:
7DSBGb_en 12.2022

Copyright:
©Festo SE & Co. KG
Ruiter Straße 82
73734 Esslingen
Germany

Editorial team:
Spare Part Documentation and
Support

Phone:
+49 / 711 / 347-0

Fax:
+49 / 711 / 347-2144

Email:
service_international@festo.com

Internet:
www.festo.com

Reproduction, distribution or sale of this document or communication of its contents to others without express authorisation is prohibited. Offenders will be held liable for damages. All rights reserved in the event that a patent, utility model or design patent is registered.

All product designations and brand names used are the property of the owners and not explicitly identified as such.

All technical data are subject to change according to technical updates.

Foreword

These repair instructions are valid for the ISO cylinder listed on the title page to the exclusion of any liability claims.

The descriptions in these repair instructions may differ depending on the version and/or modification status of the ISO cylinder. The user must check this prior to carrying out the repair and take the deviations into consideration if necessary.

These repair instructions have been prepared with care.

Festo SE & Co. KG does not, however, accept liability for any errors in these repair instructions or their consequences. Likewise, no liability is accepted for direct or consequential damage resulting from incorrect use of the products.

Further information is given in [Chapter 8 on page 48](#).

The relevant regulations on occupational safety, safety engineering, and interference suppression as well as the stipulations contained in these repair instructions must be observed when working on the products.

Table of Contents

1	Important information	6
1.1	About these repair instructions	6
1.2	Symbols used in these repair instructions	6
1.3	Text designations used in these repair instructions	7
1.4	General safety instructions	7
1.5	Technical requirements	8
1.6	Standards and test values	8
2	General product description	9
2.1	Functional description	9
2.2	Type code	9
2.3	Repair-relevant features	10
2.4	Orientation designations	12
2.5	Sizes and part numbers	12
3	Components list	13
3.1	DSBG-... / -A3	13
3.2	DSBG-...-T1 / T4	15
3.3	DSBG-...-T3 / A2	17
3.4	DSBG-...-A6	19
4	Repair steps	21
4.1	Preparatory steps	21
4.2	Visual inspection	22
4.3	Repairing the ISO standard cylinder DSBG-... / -A3	22
4.3.1	Requirements	22
4.3.2	Validity	22
4.3.3	Structure of the bearing cap	22
4.3.4	Removing the bearing and end caps	23
4.3.5	Replacing the piston components	23
4.3.6	Inserting the piston rod into the cylinder barrel	24
4.3.7	Repairing and attaching the bearing and end caps	25
4.4	Repairing the ISO standard cylinder DSBG-...-T1 / T4	28
4.4.1	Requirements	28
4.4.2	Validity	28
4.4.3	Structure of the bearing cap	28
4.4.4	Removing the bearing and end caps	29
4.4.5	Replacing the piston components	29
4.4.6	Inserting the piston rod into the cylinder barrel	30
4.4.7	Repairing and attaching the bearing and end caps	31
4.5	Repairing the ISO standard cylinder DSBG-...-T3 / A2	34
4.5.1	Requirements	34
4.5.2	Validity	34
4.5.3	Structure of the bearing cap	34
4.5.4	Removing the bearing and end caps	35
4.5.5	Replacing the piston components	35
4.5.6	Inserting the piston rod into the cylinder barrel	36
4.5.7	Repairing and attaching the bearing and end caps	36

Table of Contents

4.6	Repairing the ISO standard cylinder DSBG-...-A6	41
4.6.1	Requirements	41
4.6.2	Validity	41
4.6.3	Structure of the bearing cap	41
4.6.4	Removing the bearing and end caps	42
4.6.5	Replacing the piston components	42
4.6.6	Inserting the piston rod into the cylinder barrel	43
4.6.7	Repairing and attaching the bearing and end caps	43
5	Cleaning and Greasing	47
5.1	Cleaning	47
5.2	Greasing	47
5.2.1	Thin grease film	47
5.2.2	Grease reservoir	47
6	Maintenance and care	48
7	Tools	48
7.1	Standard tools	48
7.2	Special tools	48
8	Liability	48

1 Important information

1.1 About these repair instructions

This document contains important information about professional repair of the ISO cylinder of the type DSBG.

The ISO cylinder DSBG is fully repairable in the event of damage due to normal wear.

The entire ISO cylinder must be replaced in the event of damage to the cylinder barrel.

However, the costs of carrying out a repair must be considered in the case of larger defects.

Before carrying out a repair, the relevant chapter in these instructions must be read in full and followed consistently.

For reasons of clarity, these repair instructions do not contain all detailed information. The following documents should therefore also be available while performing repair work on the ISO cylinder:

- **Operating instructions**
Contains information about the operating elements and connections of the ISO cylinder, as well as information about its function, structure, application, installation, commissioning, maintenance and care, etc. This information is available on the Festo website (→ www.festo.com).
- **Spare parts documentation**
Contains an overview of the spare and wearing parts as well as information on their installation. This can be found in the online spare parts catalogue on the Festo website (→ www.festo.com/spareparts).
- **“Tools and repair accessories” information brochure**
Contains an overview of available assembly aids (e.g. lubricants, locking agent), special tools, schematic diagrams, fixtures, measuring devices, etc. The information can be found in the online spare parts catalogue on the Festo website (→ [Tools and repair accessories.pdf](#)).

1.2 Symbols used in these repair instructions

Danger categories

The following symbols identify text passages which draw attention to specific hazards.



Warning



Caution

Marking special information

The following pictograms mark passages in the text which contain special information.



Note



Information



Environment

1.3 Text designations used in these repair instructions

- Activities that can be carried out in any order.
 - 1. Activities which should be carried out in the specified order.
 - General list
 - ➔ Reference to further information
- Underlined, blue text indicates a cross-reference or hyperlink that you can click on in the PDF.

1.4 General safety instructions



Caution

Risk of injury due to unintended switching on and unexpected movements.

- Ensure that the ISO cylinder is depressurised and protected against restarting before any repair or maintenance work is carried out.



Caution

The ISO cylinder may only be repaired by authorised and trained persons in accordance with the specifications in the technical documentation and using genuine spare parts.

Installation and repair by unauthorised and untrained persons, repairs using non-original spare parts or without the technical documentation required for installation and/or repair are dangerous and therefore not permitted.

Repairs must only be carried out in conjunction with these repair instructions and the respective operating instructions for the device, as well as the documents listed in [Chapter 1.1 on page 6](#).



Caution

Lifting large loads can lead to permanent injury.

- The ISO cylinder must be lifted by several people or with suitable lifting gear, depending on its size and weight.



In the event of damage caused by unauthorised manipulation, improper use or use of non-original spare parts, all warranty and liability claims against the manufacturer expire.



Instead of carrying out the repair yourself, your local Festo sales office offers the option of having the repair carried out by Festo.

Due to the high torques, we recommend use of our repair service for cylinders with piston diameter 160 or larger.



Components and equipment replaced during repair must be disposed of in accordance with the relevant local environmental protection regulations.

1.5 Technical requirements



Note

The following instructions for safe and proper use must be observed:

- Observe the connection and ambient conditions specified in the technical data of the products and all the connected components. The product can only be operated in compliance with the relevant safety guidelines if you comply with the limit values and load limits (→ see enclosed documentation).
- The ISO cylinder must be in faultless technical condition.
- The ISO cylinder may only be operated in its original condition and without unauthorised modifications.
- The ISO cylinder is designed for industrial use.

1.6 Standards and test values



Standards and test values which products comply with and fulfil can be found in the “Technical data” sections of the enclosed documentation.

2 General product description

2.1 Functional description

The piston moves in the cylinder barrel when the cylinder chamber is pressurised. The piston rod transfers the movement to the outside. The advanced piston rod is retracted again when the other cylinder chamber is pressurised.

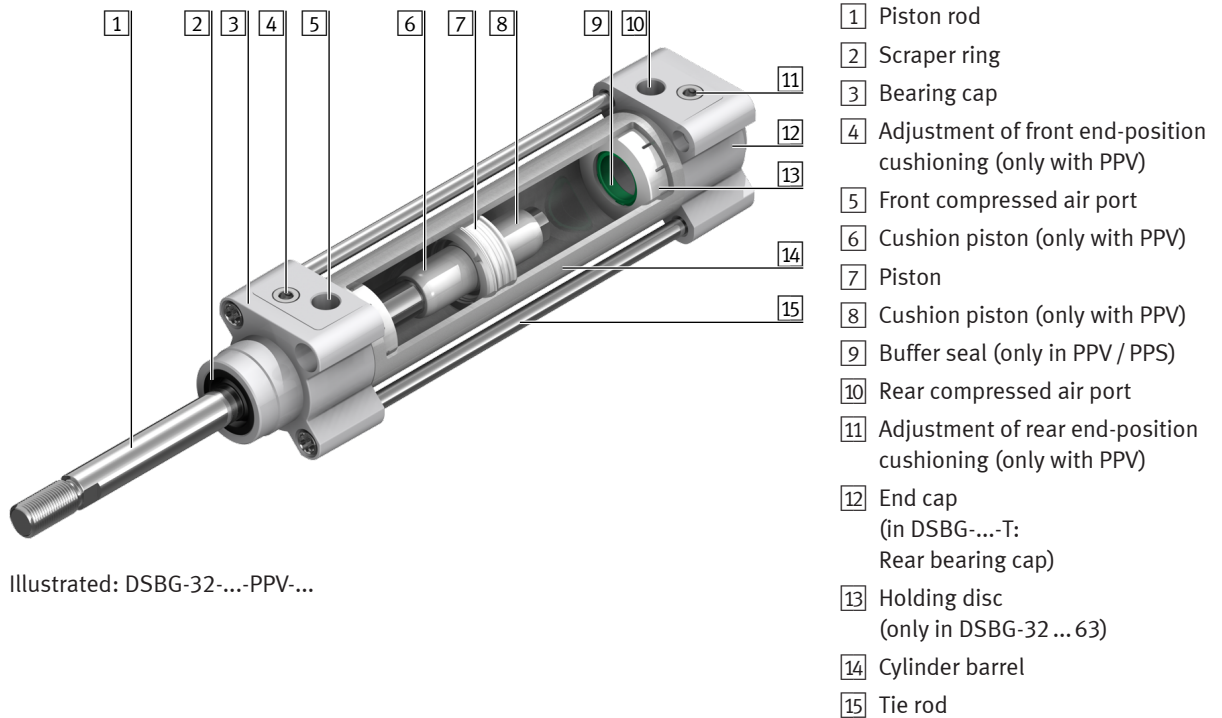

Illustrated: DSBG-32-...-PPV-...

2.2 Type code

The precise features of a standard cylinder can be determined with the help of the rating plate on the cylinder. The type code is positioned directly beneath the Festo logo and describes the features of a standard cylinder separated by a hyphen (-).

Example:

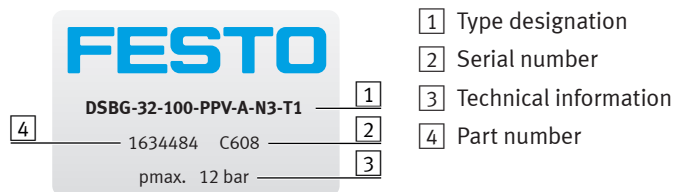

The type designation on this name plate provides the following information:

- DSBG** ISO cylinder of the type DSBG
- 32** Piston diameter 32 mm
- 100** Stroke 100 mm
- PPV** Pneumatic cushioning, adjustable at both ends
- A** Position sensing option (for proximity switch)
- N3** Conforms to ISO 15552
- T1** Heat-resistant seals 0 up to +120 °C (→ [Chapter 2.3 on page 10](#))



A list and description of all possible equipment features of the ISO cylinder can be found on the data sheet. The data sheet is available on the Festo website (→ www.festo.com).

2.3 Repair-relevant features

The ISO standard cylinder is equipped with repair-relevant and other, optional features. These features are listed in the table with a page reference to the corresponding repair instructions.

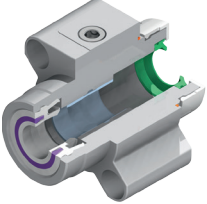
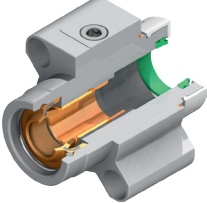
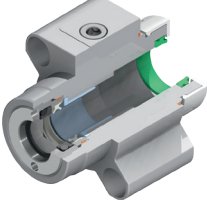
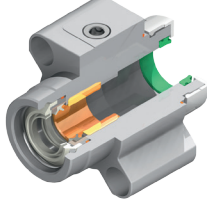
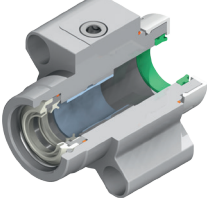
Repair-relevant features (bearing cap variants)	Other optional features	Page
 <p>DSBG-... Standard version, without repair-relevant feature</p>	<p>Q, L, U, L1, P, PPV, PPS, T, F, A, N3, R3, P2, EX4, ...V, ...Y, V, ...E, ...L, ...S, M..., B1, B2, B3, ...LB2, ...LB3</p>	<p>22</p>
 <p>DSBG-...-A3 Suitable for unlubricated operation</p>	<p>P, PPV, PPS, T, F, A, R3, ...V, ...Y, V, ...E, ...L, ...S, M..., B1, B2, B3, ...LB2, ...LB3</p>	
 <p>DSBG-...-T1 (without A6) Heat-resistant seals 0 to +120 °C</p> <p>DSBG-...-T4 (without A6) Heat-resistant seals 0 to +150 °C</p>	<p>P, PPV, T, F, A, N3, R3, ...V, ...Y, V, ...E, ...L, ...S, M..., B1, B2, B3, ...LB2, ...LB3</p>	<p>28</p>
 <p>DSBG-...-T3 (without A6) Resistant to low temperature –40 to +80 °C</p>	<p>P, PPV, T, F, A, N3, R3, ...V, ...Y, V, ...E, ...L, ...S, M..., B1, B2, B3, ...LB2, ...LB3</p>	<p>34</p>
 <p>DSBG-...-A2 Hard scraper</p>	<p>P, PPV, PPS, T, F, A, N3, EX4, ...V, ...Y, V, ...E, ...L, ...S, M..., B1, B2, B3, ...LB2, ...LB3</p>	
 <p>DSBG-...-A6 / T1-A6 / T3-A6 / T4-A6 Metal scraper</p>	<p>P, PPV, PPS, T, F, A, N3, ...V, ...Y, V, ...E, ...L, ...S, M..., B1, B2, B3, ...LB2, ...LB3</p>	<p>41</p>

Explanation of the other, optional features

Q	Piston rod, square (protection against rotation)
L	Running characteristic: low friction
U	Running characteristic: constant, slow movement
L1	Low friction for balancer applications
T	Through piston rod
F	Piston rod with female thread
P	Elastic cushioning rings/pads at both ends
PPV	Pneumatic cushioning, adjustable at both ends
PPS	Pneumatic cushioning, self-adjusting at both ends
A	Position sensing option (for proximity switch)
N3	Corresponds to ISO 15552
R3	High corrosion protection
P2	Bellows on the bearing cap
EX4	Approval II 2GD to EU Ex-Protection Directive (ATEX)
V	Middle swivel mounting
...Y	Swivel pivot mounting position, positive locking
...E	Extended piston rod
...L	Extended piston rod thread
M...	Piston rod thread
B1	Integrated spacer bolt, both ends
B2	Integrated spacer bolt, on the bearing cap
B3	Integrated spacer bolt, on the end cap
...LB2	Spacer bolt thread length, on bearing cap
...LB3	Spacer bolt thread length, on end cap

Application examples

Example 1 (from [Chapter 2.2 on page 9](#)): ISO standard cylinder DSBG-32-100-PPV-A-N3-T1-

The ISO standard cylinder includes the repair-relevant feature “**T1**”.

Use the instructions in [Chapter 4.4 on page 28](#) for repairs.

Example 2: ISO standard cylinder DSBG-32-100-PPV-A-N3-T1-A6

The ISO standard cylinder includes the repair-relevant feature combination “**T1-A6**”.

Use the instructions in [Chapter 4.6 on page 41](#) for repairs.

2.4 Orientation designations

This illustration provides an overview of the orientation designations of the ISO cylinder.

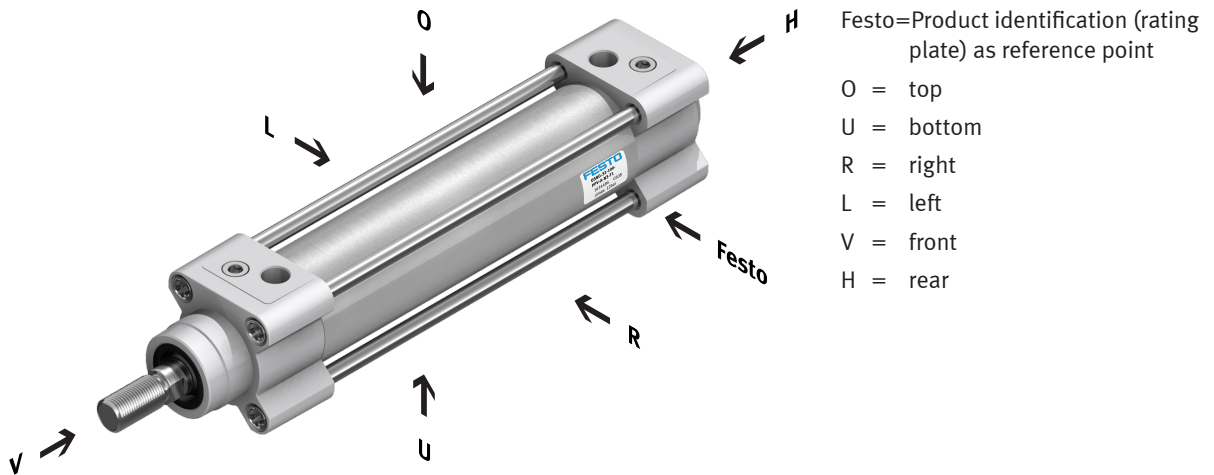

2.5 Sizes and part numbers

You will find the complete overview of features, accessories, type codes, technical data and dimensions in the product catalogue or on the Festo website (→ www.festo.com).

Size	Module number
DSBG-...-32- -	1634484
DSBG-...-40- -	1645477
DSBG-...-50- -	1646707
DSBG-...-63- -	1646738
DSBG-...-80- -	1646769
DSBG-...-100- -	1646799
DSBG-...-125- -	2045493
DSBG-...-160- -	2036032
DSBG-...-200- -	2344936
DSBG-...-250- -	2732003
DSBG-...-320- -	2776472

3 Components list

3.1 DSBG-... / -A3

This component overview does **not** apply to ISO standard cylinders with the following features: T1 / T3 / T4 / A2 / A6.

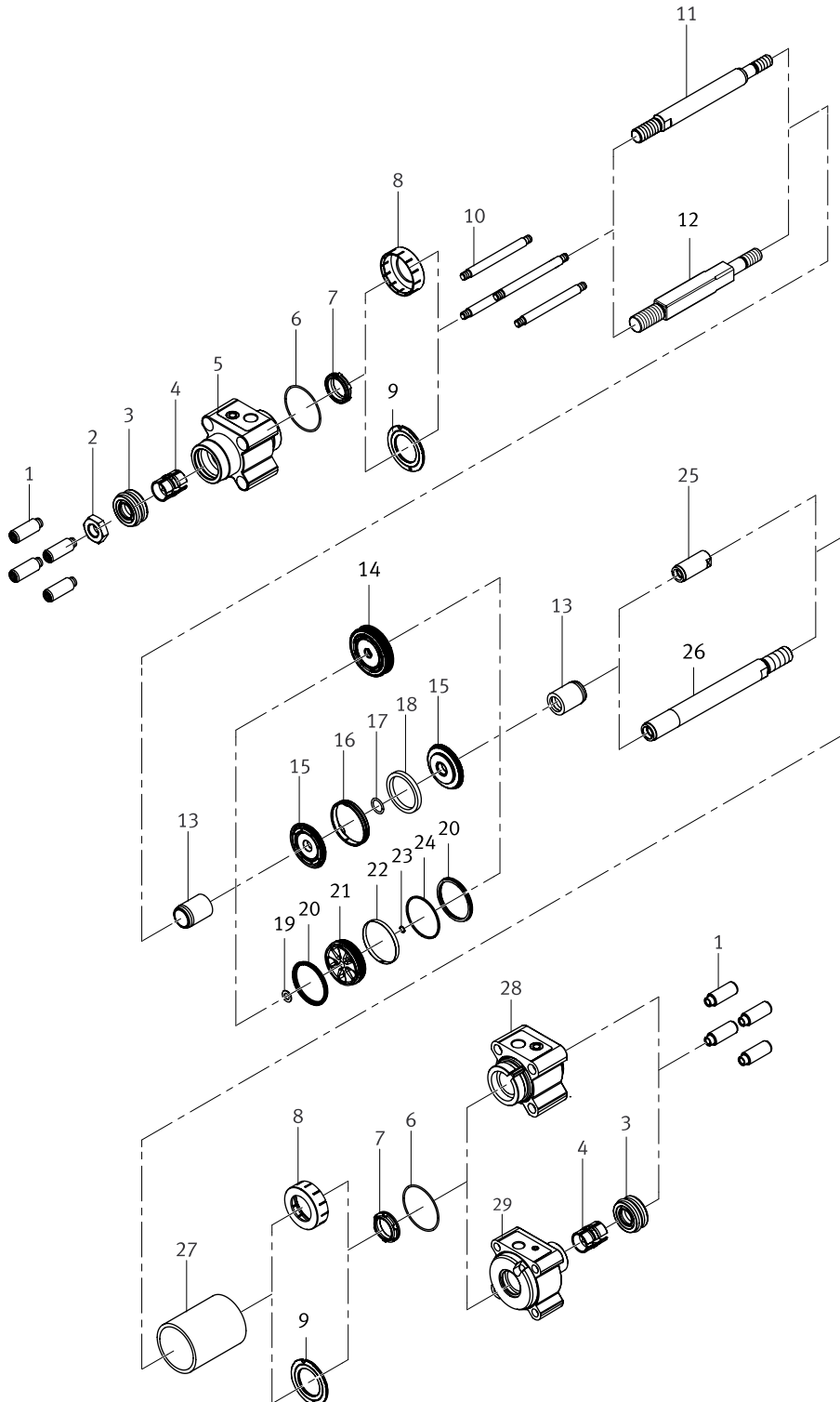

This diagram is intended to provide an overview of the individual components and an aid when ordering. For a more detailed assembly overview, refer to the online spare parts catalogue on the Festo website (→ www.festo.com/spareparts).

DSBG-... / A3		
Item	Designation	Note
1	Collar nut	
2	Hex nut	
3	Scraper ring	
4	Bearing (plastic)	interchangeable; in DSBG-...-Q/L/U/EX4: bearing (metal), pressed in, not interchangeable
5	Bearing cap	
6	O-ring	
7	Cushioning seal	only DSBG-...-PPV / PPS-...
8	Holding disc	only DSBG-32 / 40 / 50 / 63-...
9	Cushioning element	only DSBG-160 / 200 / 250 / 320-...
10	Tie rod	
11	Piston rod, round	DSBG-... (not in DSBG-...-Q)
12	Piston rod, protected against rotation	only DSBG-...-Q
13	Cushioning boss / buffer sleeve	only DSBG-...-PPV / PPS-...
14	Piston	only DSBG-32 / 40 (from E7)-...
15	Piston washer	only DSBG-40 (up to E6) / 50 / 63 / 80 / 100 / 125-...
16	Guide band	only DSBG-40 (up to E6) / 50 / 63 / 80 / 100 / 125-...
17	O-ring	only DSBG-40 (up to E6) / 50 / 63 / 80 / 100 / 125-...
18	Ring magnet	only DSBG-40 (up to E6) / 50 / 63 / 80 / 100 / 125-...
19	Washer	only DSBG-250 / 320-...
20	Lip ring	only DSBG-160 / 200 / 250 / 320-...
21	Piston	only DSBG-160 / 200 / 250 / 320-...
22	Guide band	only DSBG-160 / 200 / 250 / 320-...
23	O-ring	only DSBG-160 / 200 / 250 / 320-...
24	Magnetic strip	only DSBG-160 / 200 / 250 / 320-...
25	Threaded coupling	only DSBG-... with single-ended piston rod
26	Rear piston rod	only DSBG-...-T-... (through piston rod)
27	Cylinder barrel	
28	End cap	only DSBG-... with single-ended piston rod
29	Rear bearing cap	only DSBG-...-T-... (through piston rod)

3.2 DSBG-...-T1 / T4

This component overview does **not** apply to ISO standard cylinders with feature combinations “T1-A6” or “T4-A6”.

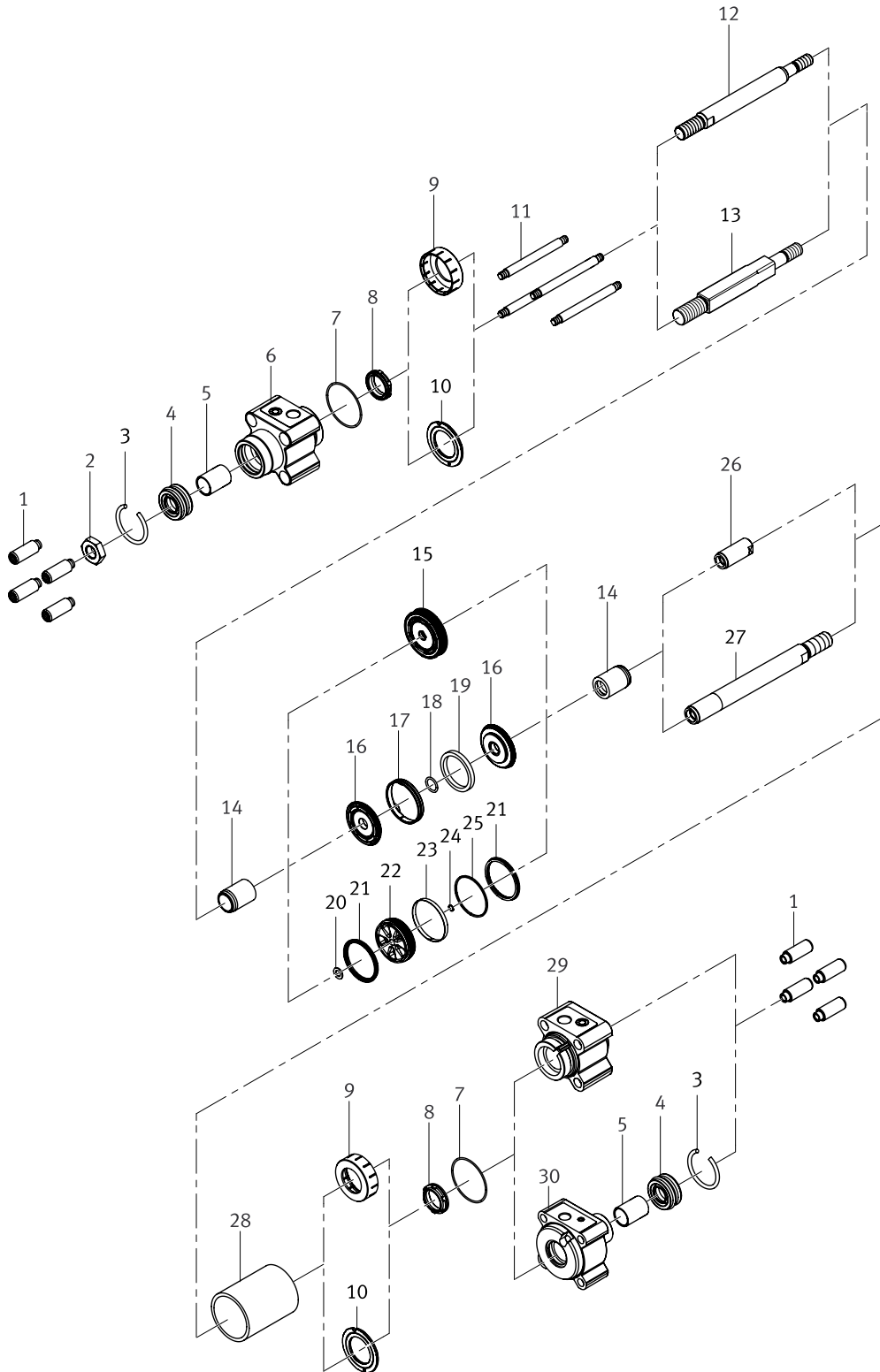

This diagram is intended to provide an overview of the individual components and an aid when ordering. For a more detailed assembly overview, refer to the online spare parts catalogue on the Festo website (→ www.festo.com/spareparts).

DSBG-...-T1 / T4		
Item	Designation	Note
1	Collar nut	
2	Hex nut	
3	Circlip	
4	Scraper ring	
5	Bearing (metal)	pressed in, not interchangeable
6	Bearing cap	
7	O-ring	
8	Cushioning seal	only DSBG-...-PPV / PPS-...
9	Holding disc	only DSBG-32 / 40 / 50 / 63-...
10	Cushioning element	only DSBG-160 / 200 / 250 / 320-...
11	Tie rod	
12	Piston rod, round	DSBG-... (not in DSBG-...-Q-...)
13	Piston rod, protected against rotation	only DSBG-...-Q-...
14	Cushioning boss / buffer sleeve	only DSBG-...-PPV / PPS-...
15	Piston	only DSBG-32 / 40 (from E7)-...
16	Piston washer	only DSBG-40 (up to E6) / 50 / 63 / 80 / 100 / 125-...
17	Guide band	only DSBG-40 (up to E6) / 50 / 63 / 80 / 100 / 125-...
18	O-ring	only DSBG-40 (up to E6) / 50 / 63 / 80 / 100 / 125-...
19	Ring magnet	only DSBG-40 (up to E6) / 50 / 63 / 80 / 100 / 125-...
20	Washer	only DSBG-250 / 320-...
21	Lip ring	only DSBG-160 / 200 / 250 / 320-...
22	Piston	only DSBG-160 / 200 / 250 / 320-...
23	Guide band	only DSBG-160 / 200 / 250 / 320-...
24	O-ring	only DSBG-160 / 200 / 250 / 320-...
25	Magnetic strip	only DSBG-160 / 200 / 250 / 320-...
26	Threaded coupling	only DSBG-... with single-ended piston rod
27	Rear piston rod	only DSBG-...-T-... (through piston rod)
28	Cylinder barrel	
29	End cap	only DSBG-... with single-ended piston rod
30	Rear bearing cap	only DSBG-...-T-... (through piston rod)

3.3 DSBG-...-T3 / A2

This component overview does **not** apply to ISO standard cylinders with the feature combination: "T3-A6".

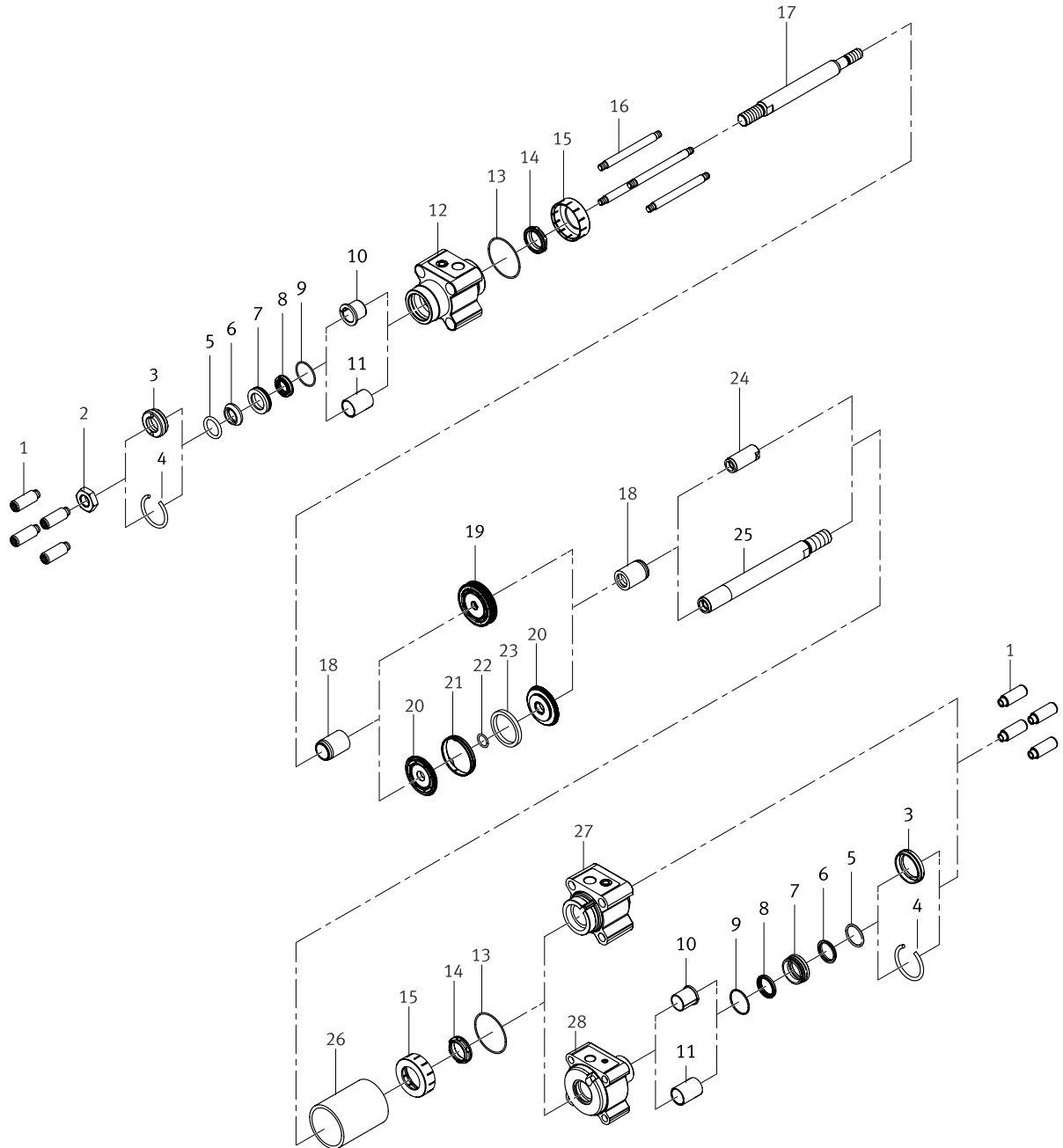

This diagram is intended to provide an overview of the individual components and an aid when ordering. For a more detailed assembly overview, refer to the online spare parts catalogue on the Festo website (→ www.festo.com/spareparts).

DSBG-...-T3 / A2		
Item	Designation	Note
1	Collar nut	
2	Hex nut	
3	Screw insert	only DSBG-32 / 40 / 50 / 63 / 80 / 100-...
4	Circlip	only DSBG-125-...
5	O-ring	
6	Excluder	
7	Insert sleeve	
8	Scraper ring	
9	O-ring	
10	Flanged bearing (plastic) Bearing (plastic)	only DSBG-32 ... 100-...-T3; interchangeable only DSBG-125-...-T3; interchangeable
11	Bearing (metal)	only DSBG-...-A2; pressed in, not interchangeable
12	Bearing cap	
13	O-ring	
14	Cushioning seal	only DSBG-...-PPV / PPS-...
15	Holding disc	only DSBG-32 / 40 / 50 / 63-...
16	Tie rod	
17	Piston rod	
18	Cushioning boss / buffer sleeve	only DSBG-...-PPV / PPS-...
19	Piston	only DSBG-32 / 40 (from E7)-...
20	Piston washer	only DSBG-40 (up to E6) / 50 / 63 / 80 / 100 / 125-...
21	Guide band	only DSBG-40 (up to E6) / 50 / 63 / 80 / 100 / 125-...
22	O-ring	only DSBG-40 (up to E6) / 50 / 63 / 80 / 100 / 125-...
23	Ring magnet	only DSBG-40 (up to E6) / 50 / 63 / 80 / 100 / 125-...
24	Threaded coupling	only DSBG-... with single-ended piston rod
25	Rear piston rod	only DSBG-...-T-... (through piston rod)
26	Cylinder barrel	
27	End cap	only DSBG-... with single-ended piston rod
28	Rear bearing cap	only DSBG-...-T-... (through piston rod)

3.4 DSBG-...-A6

This components list also applies to ISO cylinder with the feature combinations “T1-A6”, “T3-A6” or “T4-A6”.

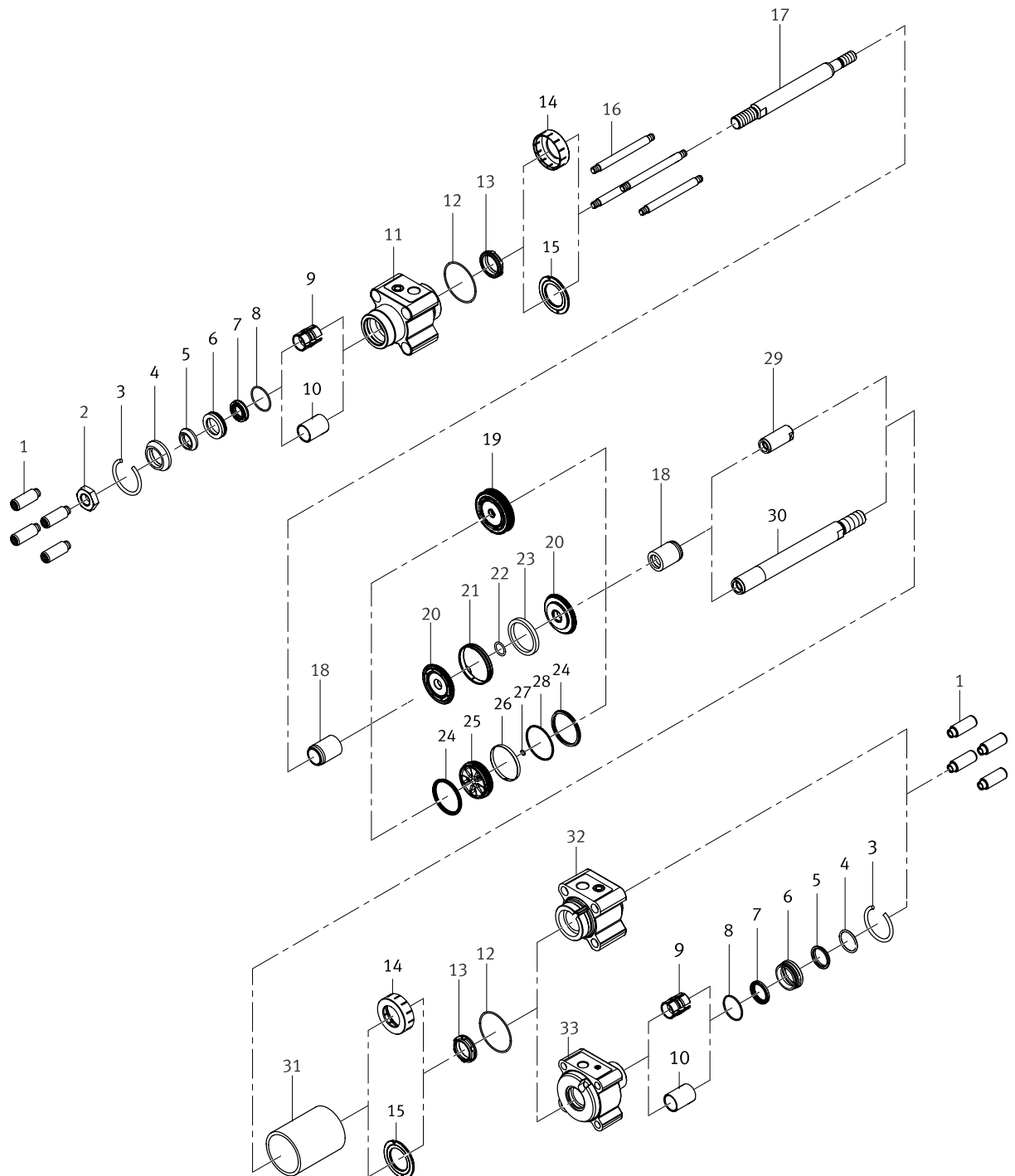

This diagram is intended to provide an overview of the individual components and an aid when ordering. For a more detailed assembly overview, refer to the online spare parts catalogue on the Festo website (→ www.festo.com/spareparts).

DSBG-... -A6		
Item	Designation	Note
1	Collar nut	
2	Hex nut	
3	Circlip	
4	Distance sleeve	
5	Scraper	
6	Insert sleeve	
7	Scraper ring	
8	O-ring	
9	Bearing (plastic)	only DSBG-...-...-A6 / T3-A6; interchangeable
10	Bearing (metal)	only DSBG-...-T1-A6 / T4-A6 (DSBG-160 / 200-... : 2-piece); pressed in, not interchangeable
11	Bearing cap	
12	O-ring	
13	Cushioning seal	only DSBG-...-PPV / PPS-...
14	Holding disc	only DSBG-32 / 40 / 50 / 63-...
15	Cushioning element	only DSBG-160 / 200-...
16	Tie rod	
17	Piston rod	
18	Cushioning boss / buffer sleeve	only DSBG-...-PPV / PPS-...
19	Piston	only DSBG-32 / 40 (from E7)-...
20	Piston washer	only DSBG-40 (up to E6) / 50 / 63 / 80 / 100 / 125-...
21	Guide band	only DSBG-40 (up to E6) / 50 / 63 / 80 / 100 / 125-...
22	O-ring	only DSBG-40 (up to E6) / 50 / 63 / 80 / 100 / 125-...
23	Ring magnet	only DSBG-40 (up to E6) / 50 / 63 / 80 / 100 / 125-...
24	Lip ring	only DSBG-160 / 200-...
25	Piston	only DSBG-160 / 200-...
26	Guide band	only DSBG-160 / 200-...
27	O-ring	only DSBG-160 / 200-...
28	Magnetic strip	only DSBG-160 / 200-...
29	Threaded coupling	only DSBG-... with single-ended piston rod
30	Rear piston rod	only DSBG-...-T-... (through piston rod)
31	Cylinder barrel	
32	End cap	only DSBG-... with single-ended piston rod
33	Rear bearing cap	only DSBG-...-T-... (through piston rod)

4 Repair steps

Where possible, it is advisable to dismantle the ISO cylinder from the system entirely before carrying out the repair. Before starting the repair, dismantle any attachments in accordance with the instructions in the accompanying operating instructions.

Keep your working environment clean and tidy.

Before dismantling the ISO cylinder the cause of the failure must be investigated to prevent repeated and premature failure. An ISO cylinder that has been used as intended will not normally exhibit any premature signs of failure.

This investigation is not necessary in the case of non-premature failure (fatigue time). However, the condition of the ISO cylinder (general condition, etc.) must always be checked.

In case of uncertainty, we recommend replacing all the components mentioned to rule out reciprocal effects during later operation.

In the event of premature failure of the ISO cylinder, the operating conditions should be examined more closely.

The following possibilities should be considered, among other things:

- **Overloading**
 - In case of overloading, the application parameters (load, speed) should be adjusted accordingly.
- **Ambient conditions/material resistance**
 - Check whether the ambient temperature is within the permissible range.
 - Check the chemical and physical ambient conditions for harmful substances, such as dust, abrasive particles, cooling lubricants, solvents, ozone, radiation, water-soluble substances, greases and oils, etc.



Note

Due to the high torques, we recommend use of our repair service for cylinders with piston diameter 160 or larger.



Note

The repair should preferably be carried out on a stable and flat work surface with storage for small parts. To prevent damage to sealing rims or guide surfaces, do not use pointed or sharp-edged assembly aids.



Note

Damage to the seals when dismantling the ISO cylinder:

- Use and replace all parts included in the set of wearing parts for the repair.



Only use the spare parts and assembly aids (grease, thread locking agent, ...) provided in the set of wearing parts.

4.1 Preparatory steps



Warning

Pressure in the ISO cylinder can dissipate suddenly on opening the cylinder.

Risk of injuries due to the bearing cap unexpected moving away.

- Before starting the repair, completely depressurise the ISO cylinder: Remove the non-return valves and tubing from the cylinder.

4.2 Visual inspection

Check the ISO cylinder for visible damage that could impair its function: such as warping of the piston rod as well as deposits and scoring.

The complete ISO cylinder must be replaced if the cylinder barrel is significantly damaged.

4.3 Repairing the ISO standard cylinder DSBG-... / -A3

4.3.1 Requirements

- Preparatory work has been completed (→ [Chapter 4.1 on page 21](#)).
- Visual inspection has been performed (→ [Chapter 4.2 on page 22](#)).

4.3.2 Validity

This chapter applies to the repair of the following versions of the ISO cylinder:

- DSBG-... (**Standard version**; without following features: T1 / T3 / T4 / A2 / A6)
- DSBG-...-A3

The different versions and features of the ISO cylinder are explained in [Chapter 2.3 on page 10](#).



The following repair steps describe and show the ISO cylinder with single-ended piston rod.

Differences in the **ISO standard cylinder with through piston rod (DSBG-...-T)**:

- Note the differences shown in the components list (→ [Chapter 3.1 on page 13](#)).
- Take into consideration the following for the repair steps:
 - Instead of threaded coupling: Rear piston rod (Item 26 in the component overview)
 - Instead of end cap: Rear bearing cap (Item 29 in the component overview)
 - Also replace the scraper ring in the rear bearing cap.

4.3.3 Structure of the bearing cap



The bearing and end caps of the various sizes and versions differ and can differ from the illustrations shown in the following. Before each repair, the parts lists of the online spare parts catalogue on the Festo website must be used to determine the precise type of bearing and end cap and must be taken into consideration in the repair (→ www.festo.com/spareparts).

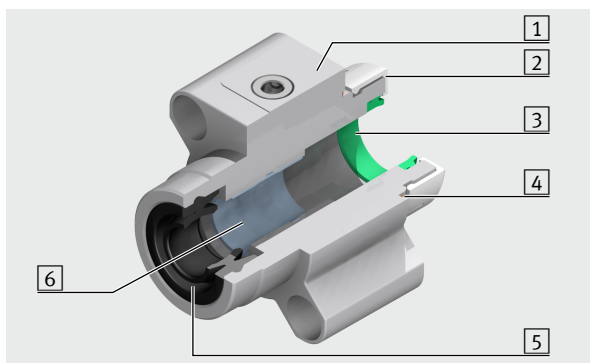

- 1 Bearing cap
- 2 Holding disc (only DSBG-32 ... 63) /
Cushioning element (only DSBG-160 ... 320, not illustrated)
- 3 Buffer seal (only DSBG-...-PPV / PPS)
- 4 O-ring
- 5 Scraper ring
- 6 Bearing (plastic), interchangeable.
In version DSBG-...-Q / L / U / EX4:
Bearing (metal), not interchangeable

Illustrated: DSBG-32-... (Standard version)

4.3.4 Removing the bearing and end caps

1. Undo the collar nuts in the end cap from the tie rods.
To do so, hold the collar nuts in the bearing cap in position.
2. Unscrew the collar nuts.
3. Pull the tie rods together with the collar nuts out of the bearing cap.
4. Pull the bearing cap off the cylinder barrel and the piston rod.
5. Pull the end cap off the cylinder barrel and the piston rod.
6. Only if the tie rods are damaged and need to be replaced:
Unscrew the collar nuts from the corresponding tie rods.

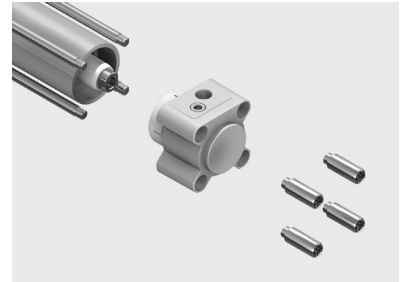

Note

We recommend replacing the tie rods.

4.3.5 Replacing the piston components

1. Pull the piston rod out of the cylinder barrel.
2. Inspect the cylinder barrel and piston rod for damage.
The entire ISO cylinder must be replaced if the cylinder barrel, particularly the bearing surface, shows signs of significant damage.

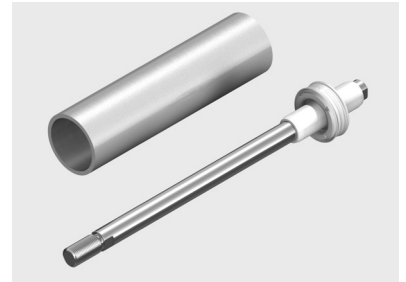

3. Unscrew the threaded coupling from the piston rod.



Note

Note the order and alignment when removing the piston components.
Recommendation: Place the piston components in such a way that correct assembly is ensured.

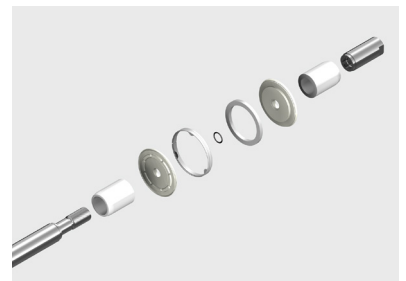

Illustrated: DSBG-63-...

4. Remove the piston components from the piston rod.
5. Clean the thread of the piston rod and the threaded coupling to remove screw locking agent.
6. Replace the components contained in the set of wearing parts.
7. Assemble the piston components on the piston rod in the correct order and alignment.

- Wet the inside of the threaded coupling with screw locking agent.
- Screw the threaded coupling onto the piston rod and tighten to the appropriate tightening torque.

Size	Tightening torque
DSBG-32	10 Nm
DSBG-40	20 Nm
DSBG-50	30 Nm
DSBG-63	40 Nm
DSBG-80	60 Nm
DSBG-100	60 Nm
DSBG-125	170 Nm
DSBG-160	330 Nm
DSBG-200	330 Nm
DSBG-250	700 Nm
DSBG-320	1200 Nm

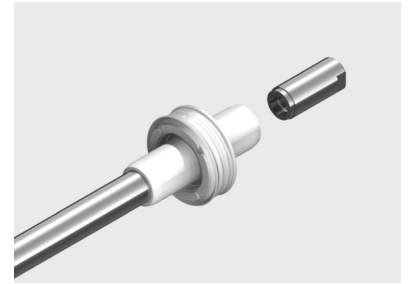

4.3.6 Inserting the piston rod into the cylinder barrel

- Clean the inside surface of the cylinder barrel (→ [Chapter 5.1 on page 47](#)).
- Grease the following components with the grease included in the set of wearing parts:

Component	Cylinder with L/U	Other cylinders
Inside surface of cylinder barrel	apply a thin film ¹⁾ of grease	apply a thin film ¹⁾ of grease
Surface of piston rod	apply a thin film ¹⁾ of grease	apply a thin film ¹⁾ of grease
Piston seal lip rings	apply a thin film ¹⁾ of grease on the outside	apply a thin film ¹⁾ of grease on the outside
Piston surface between lip rings (grease reservoir ²⁾)	Fill 1/3 with grease	Fill 2/3 with grease
Cushioning boss	apply a thin film ¹⁾ of grease on the outside	apply a thin film ¹⁾ of grease on the outside

¹⁾ → [Chapter 5.2.1 on page 47](#)

²⁾ → [Chapter 5.2.2 on page 47](#)

- Position the piston flat against the front side of the cylinder barrel.

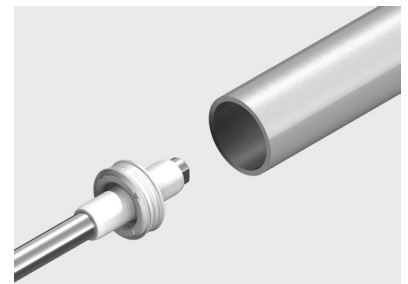

Note

The sealing lip of the lip ring may not fold back against the inside of the piston.
If necessary, push a thin piece of film rolled into a funnel shape a short way into the cylinder barrel, in order to insert the lip ring into the cylinder barrel.

- Insert the lip ring in the cylinder barrel by tilting and turning the ring slightly.
- Insert the piston fully into the cylinder barrel.
- Push the piston into the cylinder barrel until the first lip ring protrudes slightly out of the other end of the cylinder barrel.
- Pull the piston rod back again until the piston sits fully in the cylinder barrel.

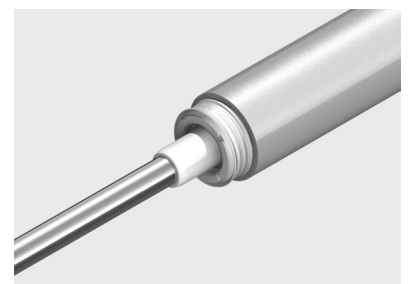

This procedure ensures that the sealing lips of the two lip rings sit correctly in the cylinder barrel.

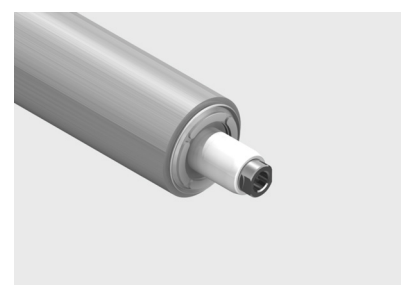

4.3.7 Repairing and attaching the bearing and end caps

1. Remove the scraper ring [1] from the bearing cap [3].
2. Remove O-ring [6] from the bearing cap and the end cap.
3. Pull the holding discs [5] off the bearing cap and end cap.
4. Remove the buffer seal [4] from the bearing cap and end cap.
5. Check the bearing [2] in the bearing cap.

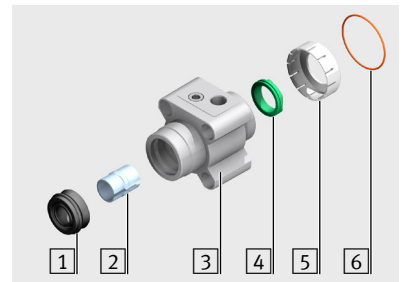

Note

ISO standard cylinder with metal bearing (DSBG-...-Q / L / U / EX4)

In case of identifiable damage to the bearing, which could impair its function (e.g. deposits or scoring), the bearing cap or the bearing cap with end position locking must be completely replaced.

6. **ISO standard cylinder with plastic bearing:**
If the bearing is damaged, press together at the inner end to unlock and push out of the bearing cap.

7. Clean the seat of the scraper ring [1].
8. Clean the seat of the buffer seal [4].
9. Clean the seat of the O-ring [5].
10. **ISO standard cylinder with plastic bearing:**
Insert new bearing into the bearing cap. Push the bearing until the middle shoulder of the bearing latches into the slot [3] in the bearing cap.
11. Grease the sliding surfaces of the bearing [2] with a thin film of the grease included in the set of wearing parts.
Fill the grease reservoir in the bearing 2/3 full with grease included in the set of wearing parts.

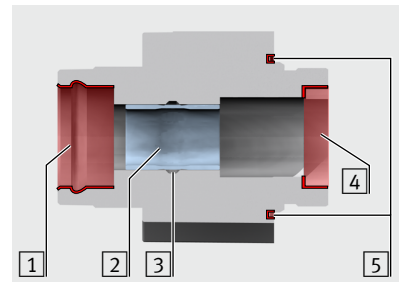

12. Grease the new scraper ring as follows:

Area	Cylinder with L / U	Other cylinders
[1] Surface facing piston rod	Apply a thin ¹⁾ film of grease on the surface	Fill grease reservoir 2/3 full with grease ²⁾
[2] External surface for bearing cap	apply a thin film ¹⁾ of grease	apply a thin film ¹⁾ of grease
[3] Grease reservoir ²⁾ for bearing	Fill 1/3 with grease	Fill 2/3 with grease

¹⁾ → [Chapter 5.2.1 on page 47](#)

²⁾ → [Chapter 5.2.2 on page 47](#)

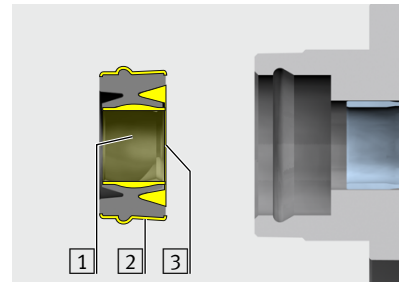

To mount the scraper ring, note the version of the ISO standard cylinder:
DSBG-...- (standard version) or DSBG-...-A3 (suitable for unlubricated operation)

DSBG-...- (standard version)



Note

Note the mounting direction of the scraper ring:
Individual sealing lip or labelling facing the outside.

13. Use a suitable thrust piece to insert the scraper ring into the bearing cap.

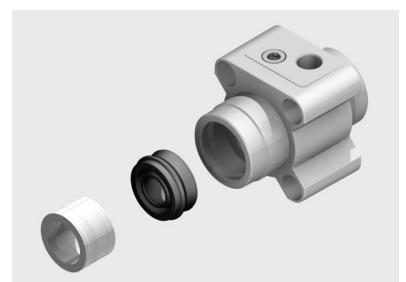

DSBG-...-A3 (suitable for unlubricated operation)



Note

To avoid damage to the scraper ring:
Insert the scraper ring only with matching mounting sleeve and the corresponding thrust piece.

1. Place the mounting sleeve with centring seat on the bearing cap.

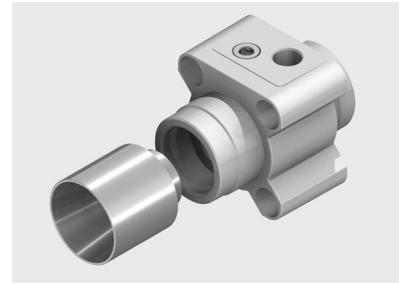

Note

Note the mounting direction of the scraper ring:
Purple coloured silicone ring facing outwards.

2. Use the thrust piece and mounting sleeve to insert the scraper ring into the bearing cap.

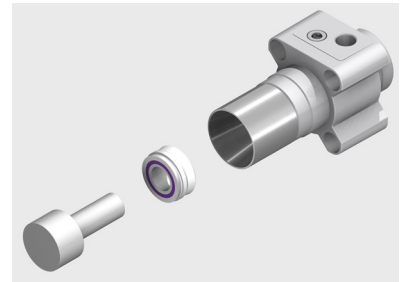

All

14. Apply a thin film of grease on the buffer seals on the front side facing the sealing surface.
15. Insert the buffer seals into the bearing cap and the end cap.
16. Place the new holding discs on the bearing cap and end cap.
17. Grease the new O-rings with the grease included in the set of wearing parts.
18. Insert the O-rings into the slot of the bearing cap and end cap.

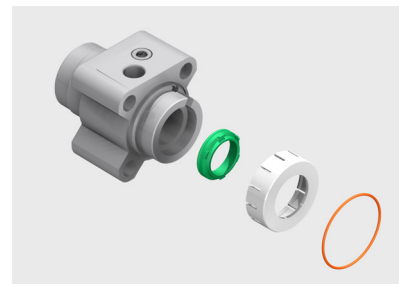

19. To avoid damage to the bearing and the seal:
Place the matching mounting sleeve on the thread of the piston rod
(→ [Chapter 7.2 on page 48](#)).
20. Guide the bearing cap over the mounting sleeve on the piston rod flush with the cylinder barrel.

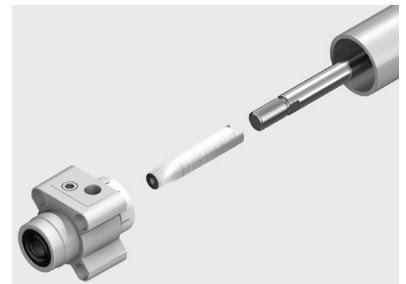

21. Push the end cap so that it is flush with the cylinder barrel.
22. Turn the end cap and bearing cap so that they align with each other.

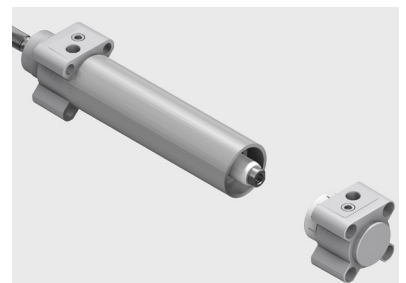

- 23. Clean the thread of the tie rod to remove the screw locking agent.
- 24. Wet the thread of the tie rod with screw locking agent.
- 25. Screw the collar nuts onto one end of the tie rods.
- 26. Push the tie rods, together with the collar nuts, through the holes in the bearing cap from the front.
- 27. Push the tie rods through the holes in the end cap. If necessary, turn the end cap into the correct position.

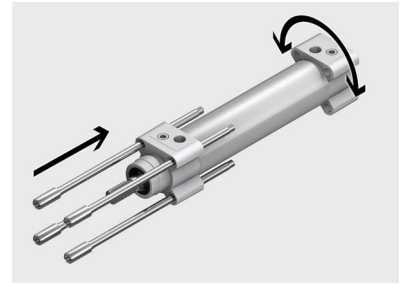

- 28. Screw the collar nuts uniformly onto the tie rods on the end cap.



Note

Size 160 to 320 only:

If the collar nuts are undone at both ends, the minimum screw-in depth must be checked and corrected if necessary before the final assembly. Otherwise the screws of attachments could “collide” with the screwed in tie rods, i.e. they cannot be tightened correctly.

It is sufficient for the minimum screw-in depth to be set at one end.

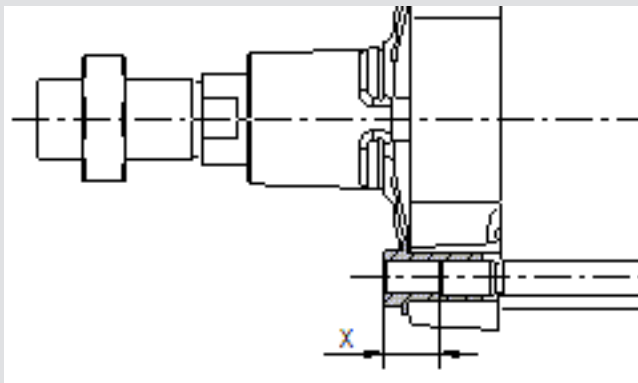

Size	Minimum screw-in depth X of the collar nuts
DSBG-160 / 200	25 ± 0.5 mm
DSBG-250	26 ± 0.5 mm
DSBG-320	29.5 ± 0.5 mm

- 29. Tighten the collar nuts crosswise to the appropriate tightening torque. To do so, hold the collar nuts on the bearing cap in position.

Size	Tightening torque
DSBG-32 / 40	4 Nm
DSBG-50 / 63	7 Nm
DSBG-80 / 100	17 Nm
DSBG-125	32 Nm
DSBG-160 / 200	100 Nm
DSBG-250	140 Nm
DSBG-320	280 Nm

- 30. Perform a functional test or start up the repaired ISO cylinder as described in the operating instructions. The operating instructions are enclosed with the ISO cylinder or can be called up on the Festo website (→ www.festo.com).

4.4 Repairing the ISO standard cylinder DSBG-...-T1 / T4

4.4.1 Requirements

- Preparatory work has been completed (→ [Chapter 4.1 on page 21](#)).
- Visual inspection has been performed (→ [Chapter 4.2 on page 22](#)).

4.4.2 Validity

This chapter applies to the repair of the following versions of the ISO cylinder:

- DSBG-...-T1 (without feature “A6”)
- DSBG-...-T4 (without feature “A6”)

The different versions and features of the ISO cylinder are explained in [Chapter 2.3 on page 10](#).



The following repair steps describe and show the ISO cylinder with single-ended piston rod.

Differences in the **ISO standard cylinder with through piston rod (DSBG-...-T)**:

- Note the differences shown in the components list (→ [Chapter 3.2 on page 15](#)).
- Take into consideration the following for the repair steps:
 - Instead of threaded coupling: Rear piston rod (Item 27 in the component overview)
 - Instead of end cap: Rear bearing cap (Item 30 in the component overview)
 - Also replace the scraper ring in the rear bearing cap.

4.4.3 Structure of the bearing cap



The bearing and end caps of the various sizes and versions differ and can differ from the illustrations shown in the following. Before each repair, the parts lists of the online spare parts catalogue on the Festo website must be used to determine the precise type of bearing and end cap and must be taken into consideration in the repair (→ www.festo.com/spareparts).

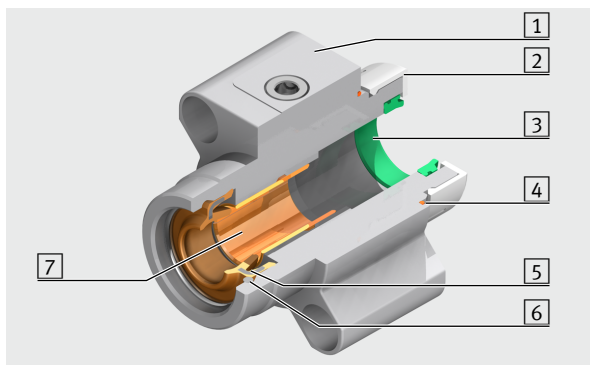

- 1 Bearing cap
- 2 Holding disc (only DSBG-32 ... 63) /
Cushioning element (only DSBG-160 ... 320; not illustrated)
- 3 Buffer seal (only DSBG-...-PPV / PPS)
- 4 O-ring
- 5 Scraper ring with metal insert
- 6 Circlip
- 7 Bearing (metal), not interchangeable

Illustrated: DSBG-32-...-T1 / T4

4.4.4 Removing the bearing and end caps

1. Undo the collar nuts in the end cap from the tie rods.
To do so, hold the collar nuts in the bearing cap in position.
2. Unscrew the collar nuts.
3. Pull the tie rods together with the collar nuts out of the bearing cap.
4. Pull the bearing cap off the cylinder barrel and the piston rod.
5. Pull the end cap off the cylinder barrel and the piston rod.
6. Only if the tie rods are damaged and need to be replaced:
Unscrew the collar nuts from the corresponding tie rods.

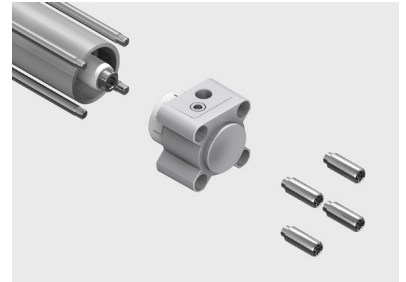

Note

We recommend replacing the tie rods.

4.4.5 Replacing the piston components

1. Pull the piston rod out of the cylinder barrel.
2. Inspect the cylinder barrel and piston rod for damage.
The entire ISO cylinder must be replaced if the cylinder barrel, particularly the bearing surface, shows signs of significant damage.

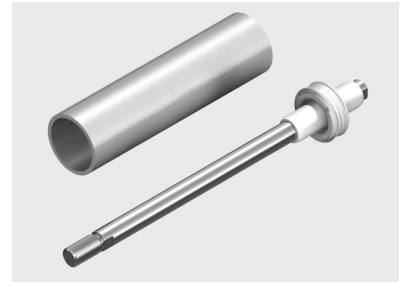

3. Unscrew the threaded coupling from the piston rod.



Note

Note the order and alignment when removing the piston components.
Recommendation: Place the piston components in such a way that correct assembly is ensured.

4. Remove the piston components from the piston rod.
5. Clean the thread of the piston rod and the threaded coupling to remove screw locking agent.
6. Replace the components contained in the set of wearing parts.
7. Assemble the piston components on the piston rod in the correct order and alignment.

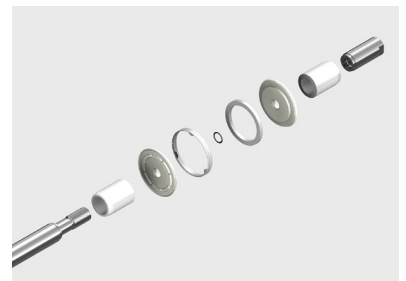

Illustrated: DSBG-63-...

8. Wet the inside of the threaded coupling with screw locking agent.
9. Screw the threaded coupling onto the piston rod and tighten to the appropriate tightening torque.

Size	Tightening torque
DSBG-32	10 Nm
DSBG-40	20 Nm
DSBG-50	30 Nm
DSBG-63	40 Nm
DSBG-80	60 Nm
DSBG-100	60 Nm
DSBG-125	170 Nm
DSBG-160	330 Nm
DSBG-200	330 Nm
DSBG-250	700 Nm
DSBG-320	1200 Nm

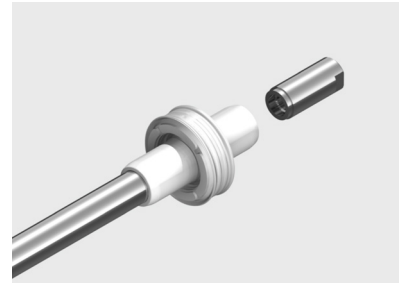

4.4.6 Inserting the piston rod into the cylinder barrel

1. Clean the inside surface of the cylinder barrel (→ [Chapter 5.1 on page 47](#)).
2. Grease the following parts with the grease included in the set of wearing parts:

Component	Greasing
Inside surface of cylinder barrel	apply a thin film ¹⁾ of grease
Surface of piston rod	apply a thin film ¹⁾ of grease
Piston seal lip rings	apply a thin film ¹⁾ of grease on the outside
Piston surface between lip rings (grease reservoir ²⁾)	Fill 2/3 with grease
Cushioning boss	apply a thin film ¹⁾ of grease on the outside

¹⁾ → [Chapter 5.2.1 on page 47](#)

²⁾ → [Chapter 5.2.2 on page 47](#)

3. Position the piston flat against the front side of the cylinder barrel.

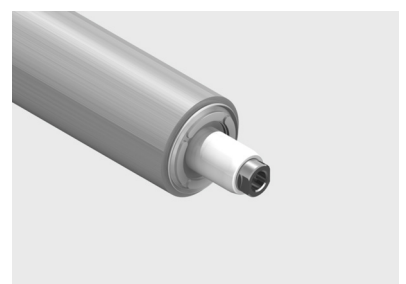
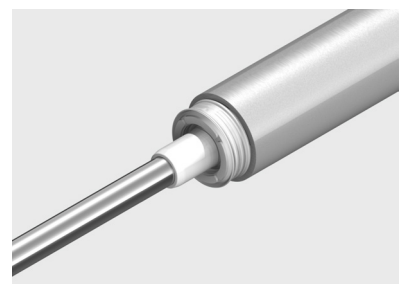
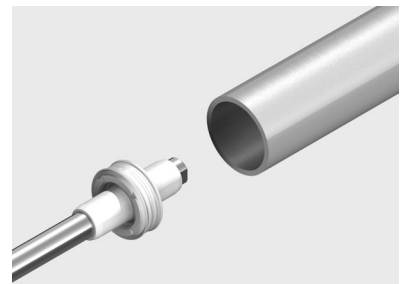

Note

The sealing lip of the lip ring may not fold back against the inside of the piston.
If necessary, push a thin piece of film rolled into a funnel shape a short way into the cylinder barrel, in order to insert the lip ring into the cylinder barrel.

4. Insert the lip ring in the cylinder barrel by tilting and turning the ring slightly.
5. Insert the piston fully into the cylinder barrel.
6. Push the piston into the cylinder barrel until the first lip ring protrudes slightly out of the other end of the cylinder barrel.
7. Pull the piston rod back again until the piston sits fully in the cylinder barrel.



This procedure ensures that the sealing lips of the two lip rings sit correctly in the cylinder barrel.

4.4.7 Repairing and attaching the bearing and end caps

1. Remove the circlip [1] and scraper ring [2] from the bearing cap [3].
2. Remove O-ring [6] from the bearing cap and the end cap.
3. Pull the holding discs [5] off the bearing cap and end cap.
4. Remove the buffer seal [4] from the bearing cap and end cap.
5. Check the bearing in the bearing cap.

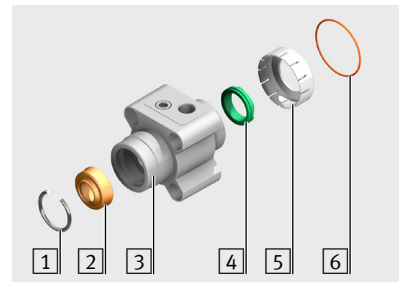

Note

In case of identifiable damage to the bearing, which could impair its function (e.g. deposits or scoring), the bearing cap must be completely replaced.

6. Clean the seat of the scraper ring [1].
7. Clean the seat of the buffer seal [3].
8. Clean the seat of the O-ring [4].
9. Grease the sliding surfaces of the bearing [2] with a thin film of the grease included in the set of wearing parts.

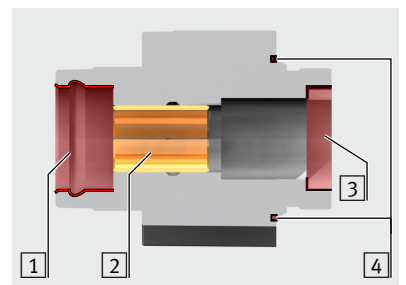

10. Grease the new scraper ring as follows:

Area	Greasing
[1] Grease reservoir ¹⁾ for piston rod	Fill 2/3 with grease
[2] External surface for bearing cap	apply a thin film ²⁾ of grease
[3] Grease reservoir ¹⁾ for bearing	Fill 2/3 with grease

¹⁾ → [Chapter 5.2.2 on page 47](#)

²⁾ → [Chapter 5.2.1 on page 47](#)

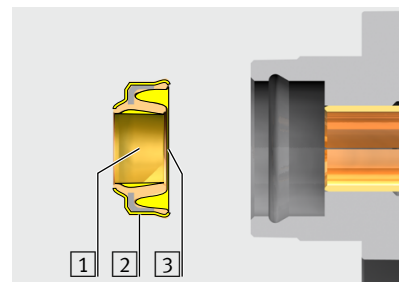

Note

Note the mounting direction of the scraper ring: Individual sealing lip or labelling facing the outside.

11. Use a suitable thrust piece to insert the scraper ring into the bearing cap.

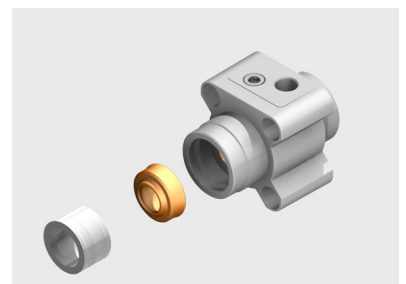

12. Press together the circlip (e.g. with the help of pliers) and insert it into the bearing cap.

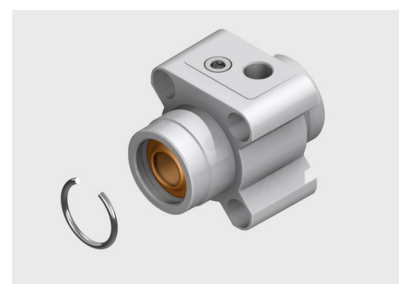

13. Apply a thin film of grease on the buffer seals on the front side facing the sealing surface.
14. Insert the buffer seals into the bearing cap and the end cap.
15. Place the new holding discs on the bearing cap and end cap.
16. Grease the new O-rings with the grease included in the set of wearing parts.
17. Insert the O-rings into the slot of the bearing cap and end cap.

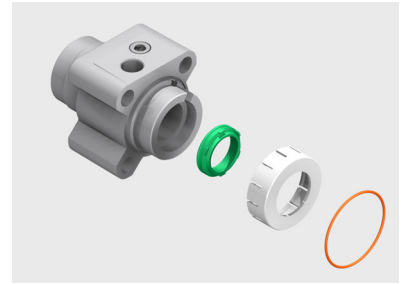

18. To avoid damage to the bearing and the seal:
Position the matching mounting sleeve on the thread of the piston rod
(→ [Chapter 7.2 on page 48](#)).
19. Guide the bearing cap over the mounting sleeve on the piston rod flush with the cylinder barrel.

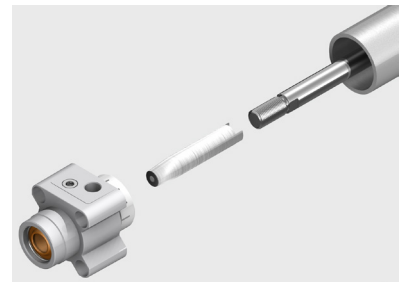

20. Push the end cap so that it is flush with the cylinder barrel.
21. Turn the end cap and bearing cap so that they align with each other.

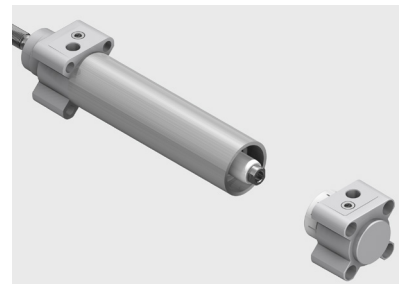

22. Clean the thread of the tie rod to remove the screw locking agent.
23. Wet the thread of the tie rod with screw locking agent.
24. Screw the collar nuts onto one end of the tie rods.
25. Push the tie rods, together with the collar nuts, through the holes in the bearing cap from the front.
26. Push the tie rods through the holes in the end cap. If necessary, turn the end cap into the correct position.

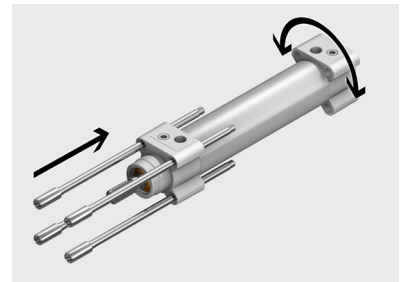

27. Screw the collar nuts uniformly onto the tie rods on the end cap.

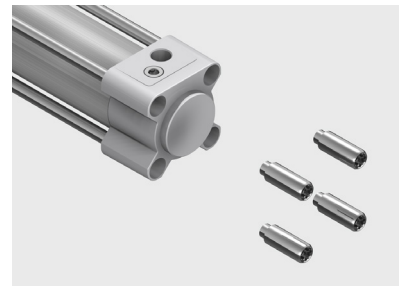

Note

Size 160 to 320 only:

If the collar nuts are undone at both ends, the minimum screw-in depth must be checked and corrected if necessary before the final assembly. Otherwise the screws of attachments could “collide” with the screwed in tie rods, i.e. they cannot be tightened correctly.

It is sufficient for the minimum screw-in depth to be set at one end.

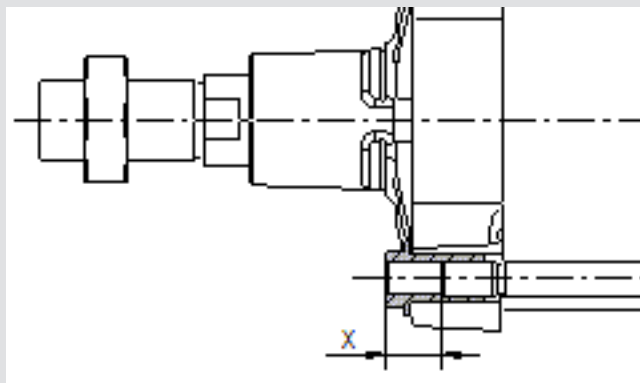

Size	Minimum screw-in depth X of the collar nuts
DSBG-160 / 200	25 ± 0.5 mm
DSBG-250	26 ± 0.5 mm
DSBG-320	29.5 ± 0.5 mm

28. Tighten the collar nuts crosswise to the appropriate tightening torque.
To do so, hold the collar nuts on the bearing cap in position.

Size	Tightening torque
DSBG-32	4 Nm
DSBG-40	4 Nm
DSBG-50	7 Nm
DSBG-63	7 Nm
DSBG-80	17 Nm
DSBG-100	17 Nm
DSBG-125	32 Nm
DSBG-160	100 Nm
DSBG-200	100 Nm
DSBG-250	140 Nm
DSBG-320	280 Nm

29. Perform a functional test or start up the repaired ISO cylinder as described in the operating instructions.

The operating instructions are enclosed with the ISO cylinder or can be called up on the Festo website (→ www.festo.com).

4.5 Repairing the ISO standard cylinder DSBG-...-T3 / A2

4.5.1 Requirements

- Preparatory work has been completed (→ [Chapter 4.1 on page 21](#)).
- Visual inspection has been performed (→ [Chapter 4.2 on page 22](#)).

4.5.2 Validity

This chapter applies to the repair of the following versions of the ISO cylinder:

- DSBG-...-T3 (without feature “A6”)
- DSBG-...-A2

The different versions and features of the ISO cylinder are explained in [Chapter 2.3 on page 10](#).



The following repair steps describe and show the ISO cylinder with single-ended piston rod.

Differences in the **ISO standard cylinder with through piston rod (DSBG-...-T)**:

- Note the differences shown in the components list (→ [Chapter 3.3 on page 17](#)).
- Take into consideration the following for the repair steps:
 - Instead of threaded coupling: Rear piston rod (Item 25 in the component overview)
 - Instead of end cap: Rear bearing cap (Item 28 in the component overview)
 - Also replace the scraper ring in the rear bearing cap.

4.5.3 Structure of the bearing cap



The bearing and end caps of the various sizes and versions differ and can differ from the illustrations shown in the following. Before each repair, the parts lists of the online spare parts catalogue on the Festo website must be used to determine the precise type of bearing and end cap and must be taken into consideration in the repair (→ www.festo.com/spareparts).

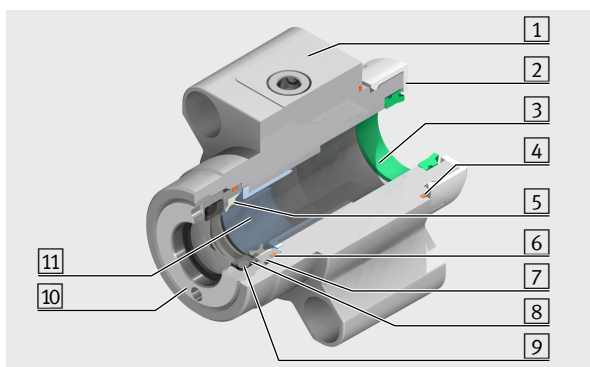

Illustrated: DSBG-32-...-T3

- 1 Bearing cap
- 2 Holding disc (only DSBG-32 ... 63)
- 3 Buffer seal (only DSBG-...-PPV / PPS)
- 4 O-ring
- 5 Scraper ring
- 6 O-ring
- 7 Insert sleeve
- 8 Excluder
- 9 O-ring
- 10 DSBG-32 ... 100: Screw insert
DSBG-125 (not illustrated): Circlip
- 11 DSBG-32 ... 100-...-T3:
Flanged bearing (plastic), interchangeable.
Not illustrated:
DSBG-125-...-T3: Bearing (plastic), interchangeable;
DSBG-...-A2: Bearing (metal), not interchangeable

4.5.4 Removing the bearing and end caps

1. Undo the collar nuts in the end cap from the tie rods.
To do so, hold the collar nuts in the bearing cap in position.
2. Unscrew the collar nuts.
3. Pull the tie rods together with the collar nuts out of the bearing cap.
4. Pull the bearing cap off the cylinder barrel and the piston rod.
5. Pull the end cap off the cylinder barrel and the piston rod.
6. Only if the tie rods are damaged and need to be replaced:
Unscrew the collar nuts from the corresponding tie rods.

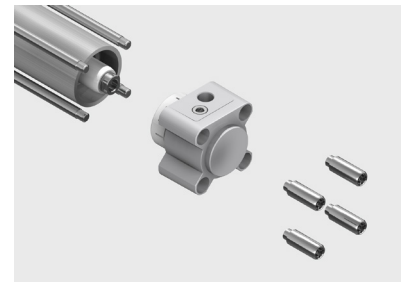

Note

We recommend replacing the tie rods.

4.5.5 Replacing the piston components

1. Pull the piston rod out of the cylinder barrel.
2. Inspect the cylinder barrel and piston rod for damage.
The entire ISO cylinder must be replaced if the cylinder barrel, particularly the bearing surface, shows signs of significant damage.

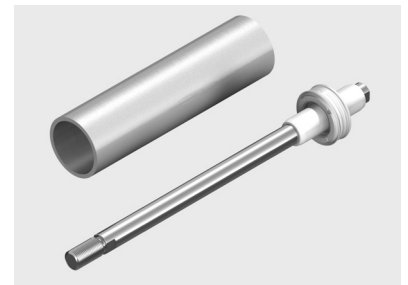

3. Unscrew the threaded coupling from the piston rod.



Note

Note the order and alignment when removing the piston components.
Recommendation: Place the piston components in such a way that correct assembly is ensured.

4. Remove the piston components from the piston rod.
5. Clean the thread of the piston rod and the threaded coupling to remove screw locking agent.
6. Replace the components contained in the set of wearing parts.
7. Assemble the piston components on the piston rod in the correct order and alignment.
8. Wet the inside of the threaded coupling with screw locking agent.
9. Screw the threaded coupling onto the piston rod and tighten to the appropriate tightening torque.

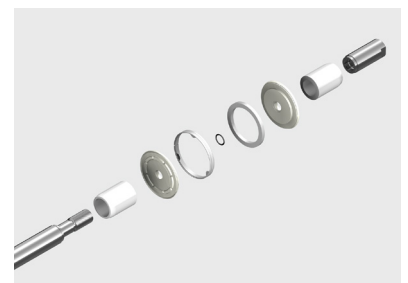

Illustrated: DSBG-63-...

Size	Tightening torque
DSBG-32	10 Nm
DSBG-40	20 Nm
DSBG-50	30 Nm
DSBG-63	40 Nm
DSBG-80	60 Nm
DSBG-100	60 Nm
DSBG-125	170 Nm

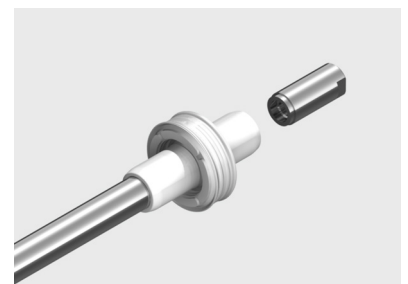

4.5.6 Inserting the piston rod into the cylinder barrel

1. Clean the inside surface of the cylinder barrel (→ [Chapter 5.1 on page 47](#)).
2. Grease the following components with the grease included in the set of wearing parts:

Component	Greasing
Inside surface of cylinder barrel	apply a thin film ¹⁾ of grease
Surface of piston rod	apply a thin film ¹⁾ of grease
Piston seal lip rings	apply a thin film ¹⁾ of grease on the outside
Piston surface between lip rings (grease reservoir ²⁾)	Fill 2/3 with grease
Cushioning boss	apply a thin film ¹⁾ of grease on the outside

¹⁾ → [Chapter 5.2.1 on page 47](#)

²⁾ → [Chapter 5.2.2 on page 47](#)

3. Position the piston flat against the front side of the cylinder barrel.

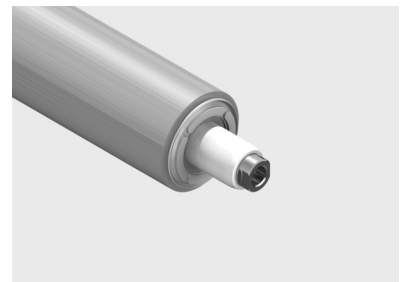
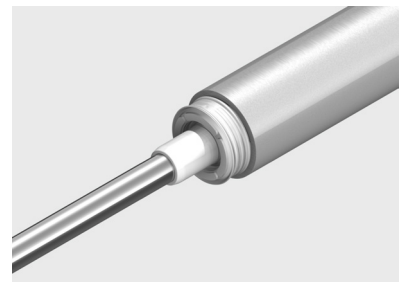
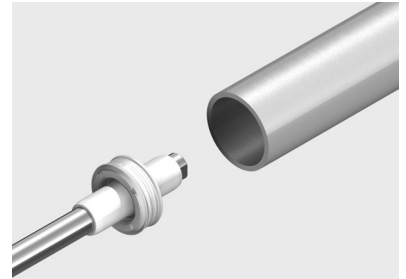

Note

The sealing lip of the lip ring may not fold back against the inside of the piston.
If necessary, push a thin piece of film rolled into a funnel shape a short way into the cylinder barrel, in order to insert the lip ring into the cylinder barrel.

4. Insert the lip ring in the cylinder barrel by tilting and turning the ring slightly.
5. Insert the piston fully into the cylinder barrel.
6. Push the piston into the cylinder barrel until the first lip ring protrudes slightly out of the other end of the cylinder barrel.
7. Pull the piston rod back again until the piston sits fully in the cylinder barrel.



This procedure ensures that the sealing lips of the two lip rings sit correctly in the cylinder barrel.

4.5.7 Repairing and attaching the bearing and end caps

DSBG-32 ... 100

1. Unscrew the screw insert [1] from the bearing cap [8].
2. Remove the excluder [3] and O-ring [2] from the screw insert.
3. Remove the insert sleeve [4] with scraper ring [5] and O-ring [6] from the bearing cap.
4. Separate the scraper ring and O-ring from the insert sleeve.

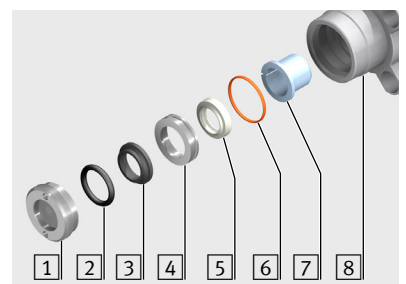

Illustrated: DSBG-32-...-T3

DSBG-125

1. Remove the circlip [1] from the bearing cap [8].
2. Remove the insert sleeve [4] with excluder [3], O-ring [2], scraper ring [5] and O-ring [6] from the bearing cap.
3. Separate the scraper ring and O-ring from the insert sleeve.
4. Remove the excluder and O-ring from the insert sleeve.

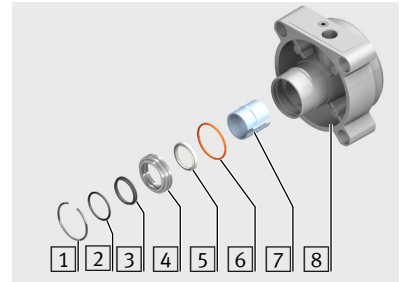

Illustrated: DSBG-125-...-T3

All

5. Remove the O-ring [4] from the bearing cap [1] and end cap.
6. Pull the holding discs [3] off the bearing cap and end cap.
7. Remove the buffer seal [2] from the bearing cap and end cap.
8. Check the bearing in the bearing cap.

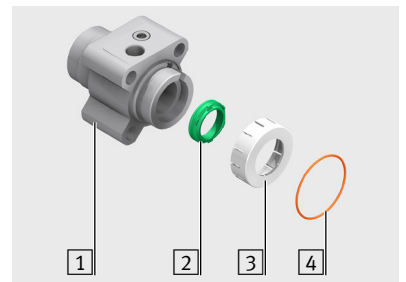

Note

ISO standard cylinder with metal bearing (DSBG-...-A2)

In case of identifiable damage to the bearing, which could impair the function (e.g. deposits or scoring), the bearing cap must be completely replaced.

9. ISO standard cylinder with plastic bearing (DSBG-...-T3):

If the bearing is damaged, press together at the inner end and push out of the bearing cap.

10. **DSBG-32... 100:** Clean the thread of the bearing cap [1] and of the screw insert to remove screw locking agent.
11. Clean the seat of the insert sleeve [1] in the bearing cap.
12. Clean the seat of the buffer seal [4].
13. Clean the seat of the O-ring [5].
14. **ISO standard cylinder with plastic bearing (DSBG-...-T3):** Insert the new bearing into the bearing cap.
15. **DSBG-125-...-T3:** Push the bearing until the middle shoulder of the bearing latches into the slot [3] in the bearing cap.
16. Grease the sliding surfaces of the bearing [2] with a thin film of the grease included in the set of wearing parts.
17. **DSBG-125-...-T3:** Fill the grease reservoir 2/3 full with grease included in the set of wearing parts.

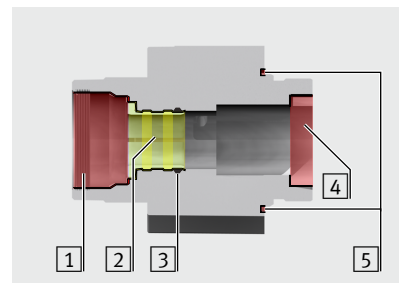

18. Clean the seat of the scraper ring [2] and of the O-ring [4] on the insert sleeve [1].
19. Grease the outside [3] of the insert sleeve.
20. Grease the new scraper ring [6] as follows:

Area	Greasing
[5] External surface facing insert sleeve	apply a thin film ¹⁾ of grease
[7] Grease reservoir ²⁾ for bearing	Fill 2/3 with grease
[8] Grease reservoir ²⁾ for piston rod	Fill 2/3 with grease

¹⁾ → [Chapter 5.2.1 on page 47](#)

²⁾ → [Chapter 5.2.2 on page 47](#)

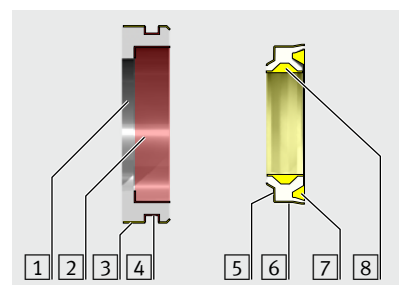

Illustrated: DSBG-32-...



Note

Note the mounting direction of the scraper ring:
Protruding sealing lip facing outwards, grease reservoir facing inwards.

21. Insert the greased scraper ring into the insert sleeve.
22. Grease the new O-ring with the grease included in the set of wearing parts.
23. Insert the O-ring into the outer slot +-of the insert sleeve.

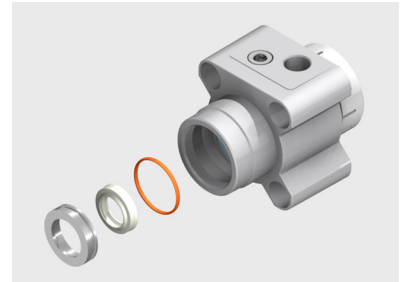

Illustrated: DSBG-32-...

DSBG-125

1. Grease the O-ring [1] and excluder [2] with the grease included in the set of wearing parts.



Note

Note the mounting direction and order:
O-ring between the outside insert sleeve and the excluder.

2. Insert the O-ring and excluder together into the insert sleeve [3].

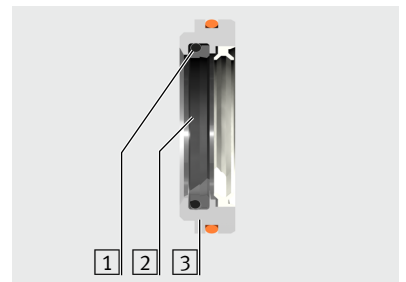

All sizes



Note

Note the mounting direction of the insert sleeve: Chamfer faces the bearing cap.

24. Insert the insert sleeve into the bearing cap.

DSBG-32... 100

25. Grease the O-ring and excluder with the grease included in the set of wearing parts.



Note

Note the mounting direction and order:
O-ring between the screw insert and excluder.

26. Insert the O-ring and excluder together into the screw insert.
27. Wet the thread of the screw insert with screw locking agent.
28. Screw the screw insert into the bearing cap and tighten to the appropriate torque.

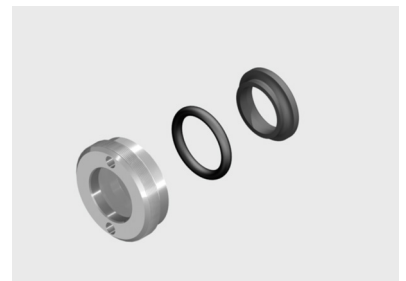

Size	Tightening torque
DSBG-32	4 Nm
DSBG-40	8 Nm
DSBG-50 / 63	11 Nm
DSBG-80 / 100	15 Nm



DSBG-125

- Press together the circlip (e.g. using pliers) and insert it into the bearing cap.



All

29. Apply a thin film of the grease included in the set of wearing parts on the new buffer seals on the front side facing the sealing surface.
30. Insert the buffer seals into the bearing cap and the end cap.
31. Place the new holding discs on the bearing cap and end cap.
32. Grease the new O-rings with the grease included in the set of wearing parts.
33. Insert the O-rings into the slot of the bearing cap and end cap.

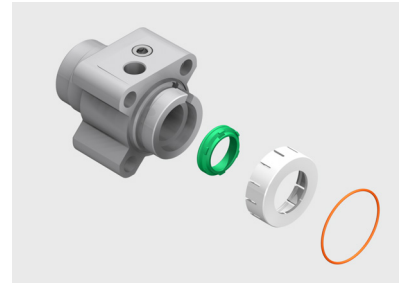

34. To avoid damage to the bearing and the seal:
Position the matching mounting sleeve on the thread of the piston rod
(→ [Chapter 7.2 on page 48](#)).
35. Guide the bearing cap over the mounting sleeve on the piston rod flush with the cylinder barrel.

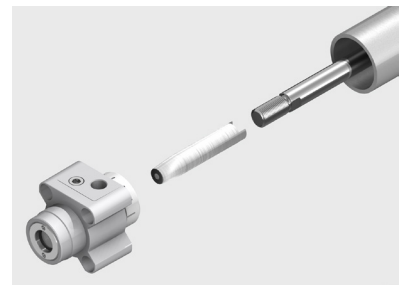

36. Push the end cap so that it is flush with the cylinder barrel.
37. Turn the end cap and bearing cap so that they align with each other.

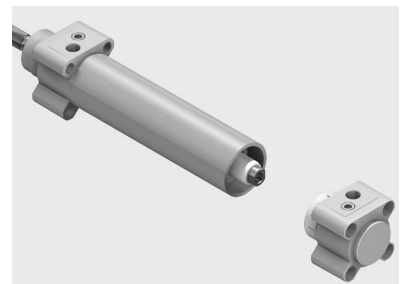

38. Clean the thread of the tie rod to remove the screw locking agent.
39. Wet the thread of the tie rod with screw locking agent.
40. Screw the collar nuts onto one end of the tie rods.
41. Push the tie rods, together with the collar nuts, through the holes in the bearing cap from the front.
42. Push the tie rods through the holes in the end cap. If necessary, turn the end cap into the correct position.

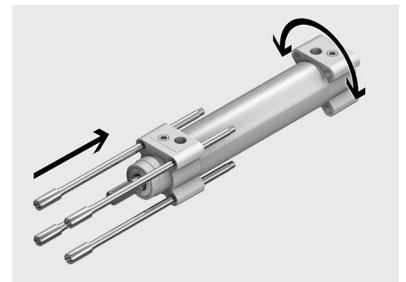

43. Screw the collar nuts uniformly onto the tie rods on the end cap.



Note

Size 160 to 320 only:

If the collar nuts are undone at both ends, the minimum screw-in depth must be checked and corrected if necessary before the final assembly. Otherwise the screws of attachments could “collide” with the screwed in tie rods, i.e. they cannot be tightened correctly.

It is sufficient for the minimum screw-in depth to be set at one end.

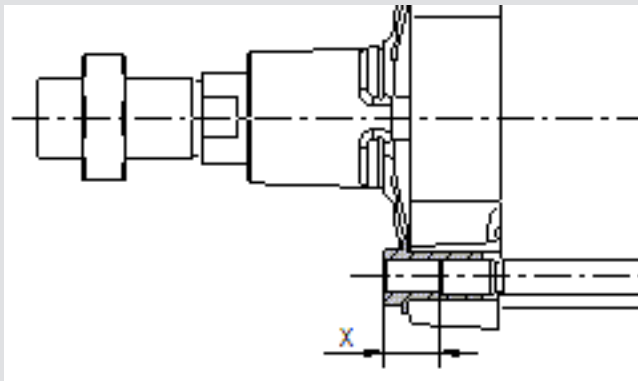

Size	Minimum screw-in depth X of the collar nuts
DSBG-160 / 200	25 ± 0.5 mm
DSBG-250	26 ± 0.5 mm
DSBG-320	29.5 ± 0.5 mm

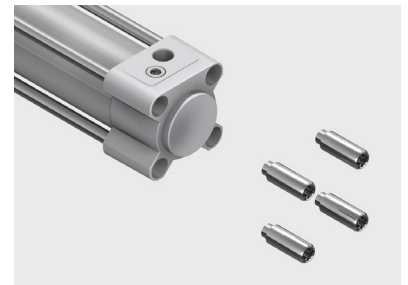

44. Tighten the collar nuts crosswise to the appropriate tightening torque.
To do so, hold the collar nuts on the bearing cap in position.

Size	Tightening torque
DSBG-32 / 40	4 Nm
DSBG-50 / 63	7 Nm
DSBG-80 / 100	17 Nm
DSBG-125	32 Nm

45. Perform a functional test or start up the repaired ISO cylinder as described in the operating instructions.

The operating instructions are enclosed with the ISO cylinder or can be called up on the Festo website (→ www.festo.com).

4.6 Repairing the ISO standard cylinder DSBG-...-A6

4.6.1 Requirements

- Preparatory work has been completed (→ [Chapter 4.1 on page 21](#)).
- Visual inspection has been performed (→ [Chapter 4.2 on page 22](#)).

4.6.2 Validity

This chapter applies to the repair of the following versions of the ISO cylinder:

- DSBG-...-A6 / T1-A6 / T3-A6 / T4-A6

The different versions and features of the ISO cylinder are explained in [Chapter 2.3 on page 10](#).



The following repair steps describe and show the ISO cylinder with single-ended piston rod.

Differences in the **ISO standard cylinder with through piston rod (DSBG-...-T)**:

- Note the differences illustrated in the component overview ([Chapter 3.4 on page 19](#)).
- Take into consideration the following for the repair steps:
 - Instead of threaded coupling: Rear piston rod (Item 30 in the component overview)
 - Instead of end cap: Rear bearing cap (Item 33 in the component overview)
 - Also replace the scraper ring in the rear bearing cap.

4.6.3 Structure of the bearing cap



The bearing and end caps of the various sizes and versions differ and can differ from the illustrations shown in the following. Before each repair, the parts lists of the online spare parts catalogue on the Festo website must be used to determine the precise type of bearing and end cap and must be taken into consideration in the repair (→ www.festo.com/spareparts).

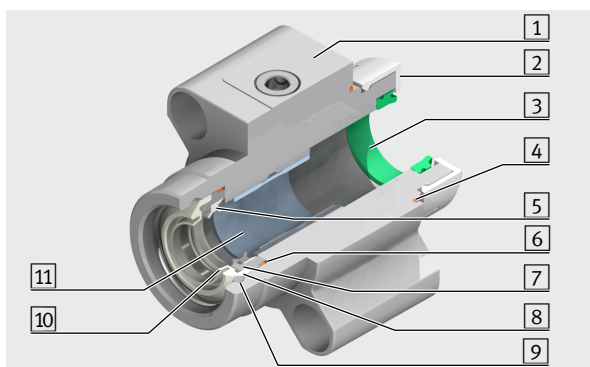

Illustrated: DSBG-32-...-T3-A6

- 1 Bearing cap
- 2 Holding disc (only DSBG-32 ... 63) /
Cushioning element (only DSBG-160 / 200; not illustrated)
- 3 Buffer seal (only DSBG-...-PPV / PPS)
- 4 O-ring
- 5 Scraper ring
- 6 O-ring
- 7 Insert sleeve
- 8 Distance sleeve
- 9 Circlip
- 10 Scraper
- 11 DSBG-...-A6 / T3-A6: Bearing (plastic), interchangeable.
Not illustrated:
DSBG-...-T1-A6 / T4-A6: Bearing (metal),
not interchangeable;
DSBG-160 / 200-...-T1-A6 / T4-A6: 2-piece bearing

4.6.4 Removing the bearing and end caps

1. Undo the collar nuts in the end cap from the tie rods.
To do so, hold the collar nuts in the bearing cap in position.
2. Unscrew the collar nuts.
3. Pull the tie rods together with the collar nuts out of the bearing cap.
4. Pull the bearing cap off the cylinder barrel and the piston rod.
5. Pull the end cap off the cylinder barrel and the piston rod.
6. Only if the tie rods are damaged and need to be replaced:
Unscrew the collar nuts from the corresponding tie rods.

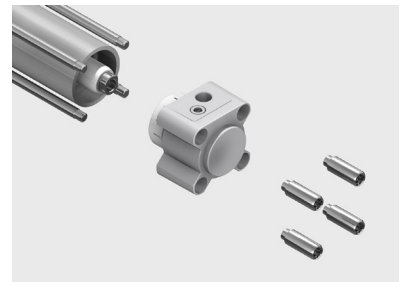

Note

We recommend replacing the tie rods.

4.6.5 Replacing the piston components

1. Pull the piston rod out of the cylinder barrel.
2. Inspect the cylinder barrel and piston rod for damage.
The entire ISO cylinder must be replaced if the cylinder barrel, particularly the bearing surface, shows signs of significant damage.

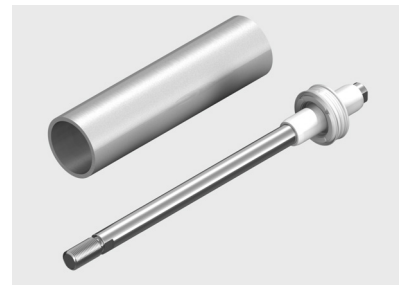

3. Unscrew the threaded coupling from the piston rod.



Note

Note the order and alignment when removing the piston components.

Recommendation: Place the piston components in such a way that correct assembly is ensured.

4. Remove the piston components from the piston rod.
5. Clean the thread of the piston rod and the threaded coupling to remove screw locking agent.
6. Replace the components contained in the set of wearing parts.
7. Assemble the piston components on the piston rod in the correct order and alignment.
8. Wet the inside of the threaded coupling with screw locking agent.
9. Screw the threaded coupling onto the piston rod and tighten to the appropriate tightening torque.

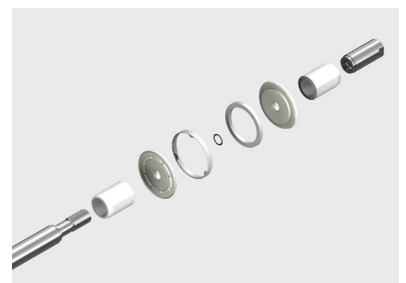

Illustrated: DSBG-63-...

Size	Tightening torque
DSBG-32	10 Nm
DSBG-40	20 Nm
DSBG-50	30 Nm
DSBG-63	40 Nm
DSBG-80	60 Nm
DSBG-100	60 Nm
DSBG-125	170 Nm
DSBG-160	330 Nm
DSBG-200	330 Nm

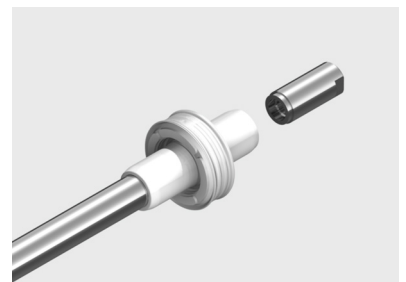

4.6.6 Inserting the piston rod into the cylinder barrel

1. Clean the inside surface of the cylinder barrel (→ [Chapter 5.1 on page 47](#)).
2. Grease the following components with the grease included in the set of wearing parts:

Component	Greasing
Inside surface of cylinder barrel	apply a thin film ¹⁾ of grease
Surface of piston rod	apply a thin film ¹⁾ of grease
Piston seal lip rings	apply a thin film ¹⁾ of grease on the outside
Piston surface between lip rings (grease reservoir ²⁾)	Fill 2/3 with grease
Cushioning boss	apply a thin film ¹⁾ of grease on the outside

¹⁾ → [Chapter 5.2.1 on page 47](#)

²⁾ → [Chapter 5.2.2 on page 47](#)

3. Position the piston flat against the front side of the cylinder barrel.

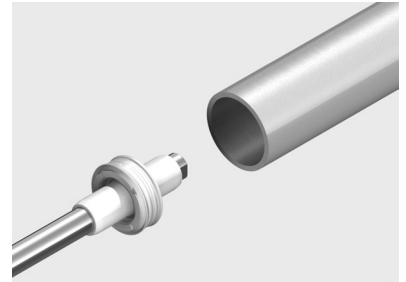

Note

The sealing lip of the lip ring may not fold back against the inside of the piston.

If necessary, push a thin piece of film rolled into a funnel shape a short way into the cylinder barrel, in order to insert the lip ring into the cylinder barrel.

4. Insert the lip ring in the cylinder barrel by tilting and turning the ring slightly.
5. Insert the piston fully into the cylinder barrel.
6. Push the piston into the cylinder barrel until the first lip ring protrudes slightly out of the other end of the cylinder barrel.
7. Pull the piston rod back again until the piston sits fully in the cylinder barrel.

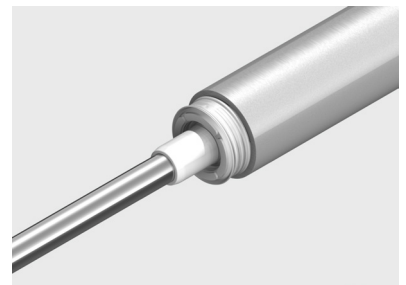

This procedure ensures that the sealing lips of the two lip rings sit correctly in the cylinder barrel.

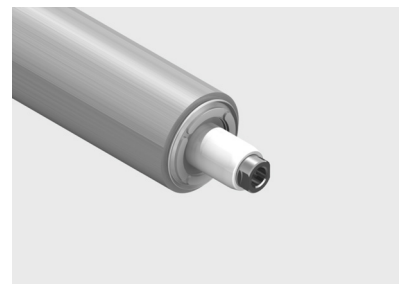

4.6.7 Repairing and attaching the bearing and end caps

1. Remove the circlip [1] from the bearing cap [8].
2. Remove the distance sleeve [2] from the bearing cap.
3. Remove the scraper [3] from the bearing cap.
4. Remove the insert sleeve [4] with scraper ring [5] and O-ring [6] from the bearing cap.
5. Separate the scraper ring and O-ring from the insert sleeve.

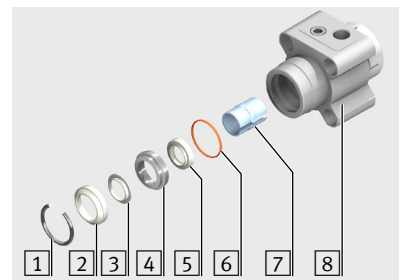

Illustrated: DSBG-32-...-T3-A6

6. Remove the O-ring [4] from the bearing cap [1] and the end cap.
7. Pull the holding discs [3] off the bearing cap and the end cap.
8. Remove the buffer seal [2] from the bearing cap and the end cap.
9. Check the bearing in the bearing cap.

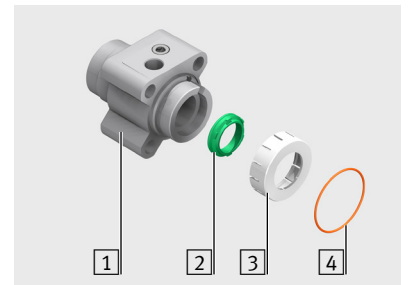

Note

ISO standard cylinder with metal bearing (DSBG-...-T1-A6 / T4-A6)

In case of identifiable damage to the bearing, which could impair its function (e.g. deposits or scoring), the bearing cap must be completely replaced.

10. ISO standard cylinder with plastic bearing (DSBG-...-A6 / T3-A6):

If the bearing is damaged, press together at the inner end to unlock and push out of the bearing cap.

11. Clean the seat of the circlip and the insert sleeve [1] in the bearing cap.
12. Clean the seat of the buffer seal [4].
13. Clean the seat of the O-ring [5].

14. ISO standard cylinder with plastic bearing (DSBG-...-A6 / T3-A6):

Insert new bearing into the bearing cap. Push the bearing until the middle shoulder of the bearing latches into the slot [3] in the bearing cap.

15. Grease the sliding surfaces of the bearing [2] with a thin film of the grease included in the set of wearing parts.
If there is a grease reservoir in the bearing, fill it 2/3 full with grease included in the set of wearing parts.

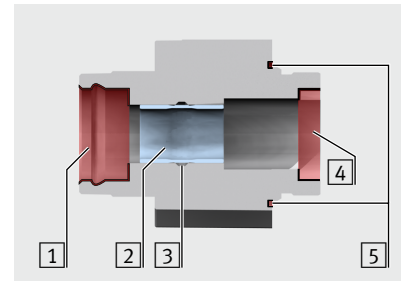

16. Clean the seat of the scraper ring [2] and of the O-ring [4] on the insert sleeve [1].

17. Grease the outside [3] of the insert sleeve.

18. Grease the new scraper ring [6] as follows:

Area	Greasing
[5] External surface facing insert sleeve	apply a thin film ¹⁾ of grease
[7] Grease reservoir ²⁾ for bearing	Fill 2/3 with grease
[8] Grease reservoir ²⁾ for piston rod	Fill 2/3 with grease

¹⁾ → [Chapter 5.2.1 on page 47](#)

²⁾ → [Chapter 5.2.2 on page 47](#)

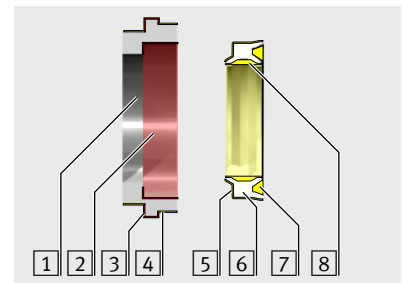

Note

Note the mounting direction of the scraper ring:
Protruding sealing lip facing outwards, grease reservoir facing inwards.

19. Insert the greased scraper ring into the insert sleeve.
20. Grease the new O-ring with the grease included in the set of wearing parts.
21. Insert the O-ring into the outer slot +-of the insert sleeve.

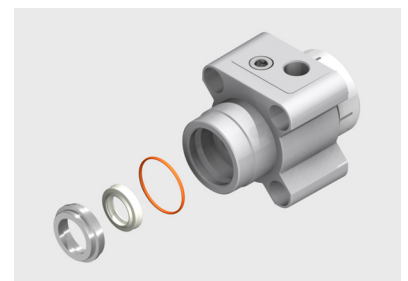

Note

Note the mounting direction of the insert sleeve: Chamfer faces the bearing cap.

22. Insert the insert sleeve into the bearing cap.

23. Insert the scraper into the bearing cap.
24. Insert the distance sleeve into the bearing cap.
25. Press together the circlip (e.g. using pliers) and insert it into the bearing cap.



26. Apply a thin film of the grease included in the set of wearing parts on the new buffer seals on the front side facing the sealing surface.
27. Insert the buffer seals into the bearing cap and the end cap.
28. Place the new holding discs on the bearing cap and end cap.
29. Grease the new O-rings with the grease included in the set of wearing parts.
30. Insert the O-rings into the slot of the bearing cap and end cap.

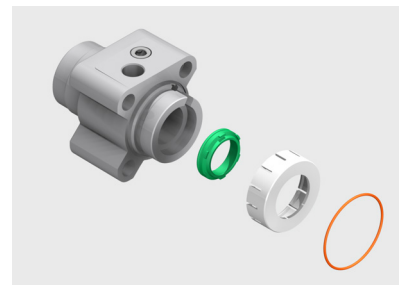

31. To avoid damage to the bearing and the seal:
Position the matching mounting sleeve on the thread of the piston rod
(→ [Chapter 7.2 on page 48](#)).
32. Guide the bearing cap over the mounting sleeve on the piston rod flush with the cylinder barrel.

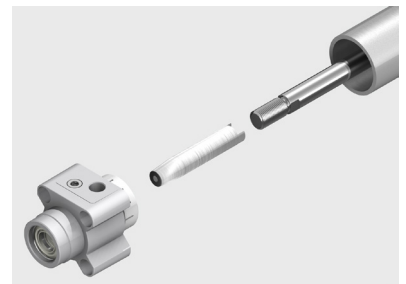

33. Push the end cap so that it is flush with the cylinder barrel.
34. Turn the end cap and bearing cap so that they align with each other.

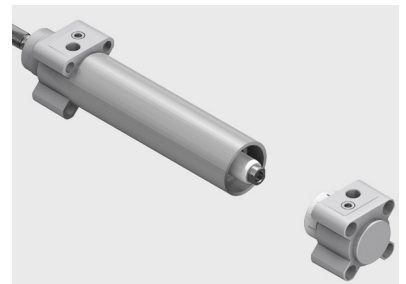

35. Clean the thread of the tie rod to remove the screw locking agent.
36. Wet the thread of the tie rod with screw locking agent.
37. Screw the collar nuts onto one end of the tie rods.
38. Push the tie rods, together with the collar nuts, through the holes in the bearing cap from the front.
39. Push the tie rods through the holes in the end cap. If necessary, turn the end cap into the correct position.

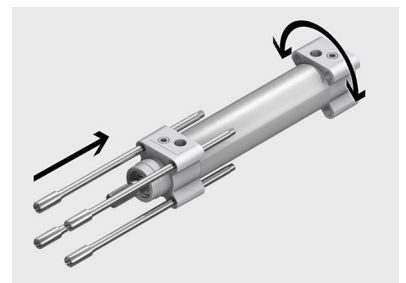

40. Screw the collar nuts uniformly onto the tie rods on the end cap.



Note

Size 160 to 320 only:

If the collar nuts are undone at both ends, the minimum screw-in depth must be checked and corrected if necessary before the final assembly. Otherwise the screws of attachments could “collide” with the screwed in tie rods, i.e. they cannot be tightened correctly.

It is sufficient for the minimum screw-in depth to be set at one end.

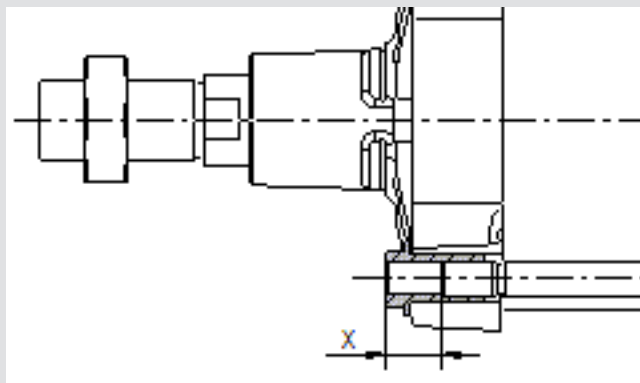

Size	Minimum screw-in depth X of the collar nuts
DSBG-160 / 200	25 ± 0.5 mm
DSBG-250	26 ± 0.5 mm
DSBG-320	29.5 ± 0.5 mm

41. Tighten the collar nuts crosswise to the appropriate tightening torque.
To do so, hold the collar nuts on the bearing cap in position.

Size	Tightening torque
DSBG-32	4 Nm
DSBG-40	4 Nm
DSBG-50	7 Nm
DSBG-63	7 Nm
DSBG-80	17 Nm
DSBG-100	17 Nm
DSBG-125	32 Nm
DSBG-160	100 Nm
DSBG-200	100 Nm

42. Perform a functional test or start up the repaired ISO cylinder as described in the operating instructions.
The operating instructions are enclosed with the ISO cylinder or can be called up on the Festo website (→ www.festo.com).

5 Cleaning and Greasing

5.1 Cleaning

The seals are designed so that the lubricant film applied to them is effective for the entire service life of the seal. The ISO cylinder must be cleaned thoroughly to remove all foreign particles, machining residues and old lubricants before it is greased to ensure this life-time lubrication is retained.

All non-abrasive cleaning agents are permissible.



Note

Regular removal of the lubricant on the surface of the piston rod reduces its service life.



Note

- Clean with a soft, lint-free cloth and non-abrasive cleaning agents.
- Check the compatibility of the cleaning agent with the materials to be cleaned.

5.2 Greasing

The various components and seals of the ISO standard cylinder require different levels of greasing depending on a number of factors.



Note

To ensure the life-time lubrication and so that a uniform lubricant film results:

- After greasing, move the piston rod with mounted piston and piston seals several times along the entire stroke of the cylinder barrel.

5.2.1 Thin grease film

A film of grease covers the bearing surface so that the grease colour darkens the surface slightly.

Recommendation:

- Apply the grease with a paint brush, a fine bristle brush or similar.

5.2.2 Grease reservoir

A defined quantity of grease is enclosed between two edges or in an enclosed ring volume.

6 Maintenance and care

The ISO standard cylinder is maintenance-free due to life-time lubrication.

7 Tools

This chapter provides an overview of the tools and accessories required to repair the ISO cylinder.

7.1 Standard tools

The following standard tools are required to repair the ISO cylinder:

- Internal hexagon socket screwdriver (Allen key)
- Screwdriver
- Wrench
- Flat pliers
- Torque wrench
- Face pin spanner (only for ISO standard cylinder DSBG-32 ... 100-...-T3 (resistant to low temperatures))

7.2 Special tools

The following special tools are required to repair the ISO cylinder:

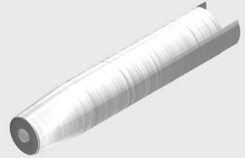
Designation	Additional information	Figure
Mounting sleeve for piston rod	<p>The mounting sleeve for piston rods for protecting the scraper ring and the bearing in the bearing cap during the repair must be made by the customer.</p> <p>The schematic diagram is included in the “Tools and repair accessories” information brochure.</p>	



For further information on the fixtures and measuring devices, refer to the **“Tools and repair accessories”** information brochure. It can be found in the online spare parts catalogue on the Festo internet site (→ [Tools and repair accessories.pdf](#)).

8 Liability

The General Terms and Conditions of Business (AGB) of Festo SE & Co. KG, which can be viewed on the Festo website (→ www.festo.com), apply.

Conditions of use for “Electronic documentation”

I. Protection rights and scope of use

The file of your choice is subject to protective provisions. Festo or third parties have protective rights to this electronic documentation, which Festo provides both on portable data storage devices (diskettes, CD ROM, removable disks) as well as on the Internet and/or intranet, referred to as electronic documentation below. In so far as third parties have whole or partial right of access to this electronic documentation, Festo has the appropriate rights of use. Festo permits the user the use under the following conditions:

1. Scope of use

- a) The user of the electronic documentation is allowed to use this documentation for his own, exclusively company-internal purposes on any number of machines within his business premises (location). This right of use includes exclusively the right to save the electronic documentation on the central processors (machines) used at the location.
- b) The electronic documentation may be printed out on a printer at the location of the user as often as desired, providing this printout is printed with or kept in a safe place together with these conditions of use and other user instructions.
- c) With the exception of the Festo logo, the user has the right to use pictures and texts from the electronic documentation for creating his own machine and system documentation. The use of the Festo logo requires written consent from Festo. The user is responsible for ensuring that the pictures and texts used match the machine/system or the product.
- d) Further uses are permitted within the following framework:
 Copying exclusively for use within the framework of machine and system documentation from electronic documents of all documented supplier components. Demonstrating to third parties exclusively under guarantee that no data material is stored wholly or partly in other networks or other data storage devices or can be reproduced there.
 Passing on printouts to third parties not covered by the regulation in item 3, as well as any processing or other use are not permitted.

2. Copyright note

Every “electronic document” receives a copyright note. This note must be included on every copy and every printout.

Example: E 2003, Festo SE & Co. KG, D-73734 Esslingen

3. Transferring the authorisation of use

The user can transfer the authorization of use in the scope of and with the limitations of the conditions in accordance with items 1 and 2 completely to a third party. The third party must be made explicitly aware of these conditions of use.

II. Exporting the electronic documentation

When exporting the electronic documentation, the licence holder must observe the export regulations of the exporting country and those of the purchasing country.

III. Warranty

1. Festo products are being continuously developed with regard to hardware and software. The hardware status and, where applicable, the software status of the product can be found on the name plate of the product. If the electronic documentation, in whatever form, is not supplied with the product, i.e. is not supplied on a data storage device (diskettes, CD ROM, removable disk) as a delivery unit with the relevant product, Festo does not guarantee that the electronic documentation corresponds to every hardware and software status of the product. In this case, the printed documentation from Festo accompanying the product alone is decisive for ensuring that the hardware and software status of the product matches that of the electronic documentation.
2. The information contained in this electronic documentation can be amended by Festo without prior notice and does not commit Festo in any way.

IV. Liability/limitations on liability

1. Festo provides this electronic documentation in order to assist the user in creating his machine and system documentation. In the case that electronic documentation in the form of data storage devices (diskettes, CD ROM, removable disk) does not accompany a product, i.e. is not automatically supplied together with that product, Festo does not guarantee that the electronic documentation separately available/supplied matches the product actually used by the user.

The latter applies particularly to extracts of the documents for the user's own documentation. The guarantee and liability for separately available/supplied portable data storage devices, i.e. with the exception of electronic documentation provided on the Internet/intranet, are limited exclusively to proper duplication of the software, whereby Festo guarantees that in each case the relevant portable data storage device or software contains the latest status of the documentation. In respect of the electronic documentation available on the Internet/Intranet, there is no guarantee that it will have the same version status as the last printed edition.

2. Furthermore, Festo cannot be held liable for the lack of economic success or for damage or claims by third parties resulting from the use of the documentation by the user, with the exception of claims arising from infringement of the protection rights of third parties concerning the use of the electronic documentation.

3. The limitations on liability as per paragraphs 1 and 2 do not apply if, in cases of intent or gross negligence or lack of warranted quality, a compulsory liability exists. In such a case, Festo's liability is limited to the damage discernable by Festo when the concrete circumstances are made known.

V. Safety guidelines/documentation

Warranty and liability claims in conformity with the aforementioned regulations (points III. and IV) may be raised only if the user has observed the safety guidelines of the documentation in conjunction with the use of the machine and its safety guidelines. The user himself is responsible for ensuring that the electronic documentation, when not supplied with the product, matches the product actually used by the user.