

### Festo AX Motion Insights Electric



GASA-MIE-CTR-\*

This document describes how to set up AX Motion Insights Electric from connectivity to asset onboarding and monitoring of electric actuators.

Title .....Festo AX Motion Insights Electric  
Version ..... 1.30  
Document no. .... 100735  
Original .....en  
Author .....Festo  
  
Last saved ..... 07.11.2025

## General information:

This document is intended for qualified, trained and instructed professionals. The data provided in this document are no guaranteed specifications, in particular with regard to functionality, condition or quality in the legal sense. The information in this document is intended only as simple indications for the implementation of a specific, hypothetical application, and in no way as a substitute for the operating instructions of the respective manufacturers or the design and testing of the respective application by the user. The respective operating instructions for Festo products can be found under [www.festo.com](http://www.festo.com). The user of this document must ensure that each function described herein works properly in his application. The user remains solely responsible for his or her own use of this document, even by studying this document and using the information mentioned therein. This also applies to any software (in source code and/or object code) that is made available to the user as an appendix to this document.

## Rights of use of the software:

If software is made available to the user as an appendix to this document, the user is granted a simple and unlimited right of use hereto. This right also includes the processing and distribution of the software to third parties in edited or unedited form. The User is not permitted to use the name "Festo" to endorse or promote products derived from the Software without express prior written permission.

Software is provided to the user "as is". Festo does not assume any warranty or guarantee with regard to software. Festo's liability for damages of any kind arising from the use of the software is limited to intent and gross negligence.

## Legal Notices:

©Festo SE & Co. KG, all rights reserved. A change in content and form is only permitted with the express written consent of Festo SE & Co. KG. Festo grants the user the right to reproduce this document in a form that remains unchanged in terms of content and form and to pass it on to third parties.



Need **support** with your **application**?  
Get in touch with your local **Technical Support**:  
[www.festo.com/contact](http://www.festo.com/contact)

# Table of contents

<b>1</b>	<b>Introduction .....</b>	<b>5</b>
<b>2</b>	<b>System Requirements.....</b>	<b>6</b>
2.1	Motor Controller and axis .....	6
2.2	Computer hardware/runtime environment.....	6
2.2.1	Hardware .....	6
2.2.2	Network .....	6
2.2.3	Software / runtime environment.....	7
2.3	Security/Intended Use .....	7
<b>3</b>	<b>Installation and Commissioning.....</b>	<b>8</b>
3.1	Installation and setup of AX MIE containers .....	8
3.1.1	Provisioning of relevant information after purchase .....	9
3.1.2	Pre-Requisites to install and run AX MIE .....	9
3.1.3	Retrieve container from Festo's container registry.....	9
3.1.4	Authenticate / Login to registry .....	10
3.1.5	Start with docker compose file.....	10
3.1.6	Version update.....	10
3.2	Initial Setup: user creation and license activation.....	11
	Further licenses can be added later according chapter 3.3.....	11
3.3	Additional licenses .....	12
<b>4</b>	<b>Onboarding of Assets .....</b>	<b>14</b>
4.1	Automatic Onboarding .....	14
4.2	Manual offboarding / deletion of assets .....	16
4.3	Initial Training .....	17
4.4	Model-Finetuning .....	17
<b>5</b>	<b>When the application is running .....</b>	<b>19</b>
5.1	UI Walkthrough .....	19
5.1.1	Main Menu (1) .....	20
5.1.2	Quick Access Buttons (2) .....	20
5.1.3	Notifications and User Profile (3) .....	20
5.2	Asset Dashboard Walkthrough.....	21
5.2.1	Asset Tree (1).....	21
5.2.2	Asset Tree Controls (2).....	21
5.2.3	Asset Main Screen (3) .....	21
5.2.4	Asset Tree Controls (4).....	22

5.3	Inviting New Users.....	22
5.4	Outbound MQTT Data Delivery.....	23
5.5	Connecting Festo AX Smartenance .....	25
5.6	Deletion of data.....	26
5.7	Debugging: System Info / Status .....	26
<b>6</b>	<b>Frequently Asked Questions.....</b>	<b>28</b>

# 1 Introduction

Festo AX Motion Insights Electric (AX MIE) is an industrial app for continuous monitoring of electric drive systems. It comes with a standardized AI model and a user interface as well as a connectivity adapter for data acquisition.



**Highlights**

- Continuous monitoring of the electric drive chain for wear and anomalies
- Direct connectivity to the servo drive
- Plug and play with Festo CMMT: data science expertise not required
- Simple display and access via the browser, including trend analysis
- One standard app that works with drives from all manufacturers

## 2 System Requirements

### 2.1 Motor Controller and axis

- Festo CMMT-AS (Profinet, EtherCAT<sup>1</sup>, Ethernet/IP, Modbus)
- Festo CMMT-ST (Profinet, EtherCAT<sup>1</sup>, Ethernet/IP, Modbus)

All linear movements are supported.

<sup>1</sup> EoE (Ethernet over Ethercat) must be powerful enough. Alternatively you can use the standard ethernet port (X18) on the CMMT for connecting Festo AX. See chapter 2.2.2.

### 2.2 Computer hardware/runtime environment

#### 2.2.1 Hardware

The Industrial App runs on industrial PCs, virtual machines (VM) or other devices and computing instances that meet the following hardware requirements:

- CPU: min. 4-core, x86-64bit (Core i5 or higher)
- HDD: 120 GB or more
- RAM: 8 GB or more
- 1x Ethernet network interface

#### 2.2.2 Network

- Device access: Ethernet network access to all involved CMMTs

Festo AX can always be connected to the X18 standard Ethernet port, regardless of the fieldbus technology. This option is particularly suitable for Ethercat, so no EoE tunnel is required.

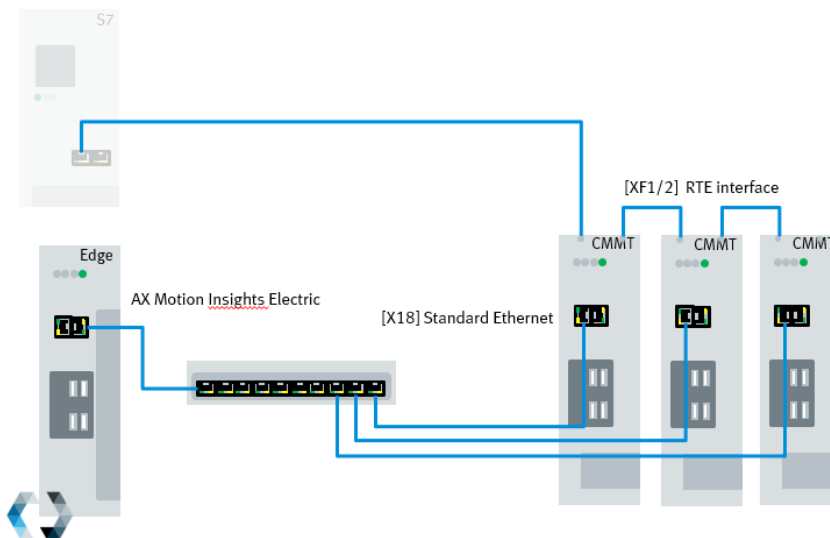

Festo AX can also be connected to TCP/ IP based fieldbus (PROFINET, EtherNet/IP, Modbus TCP) infrastructure.

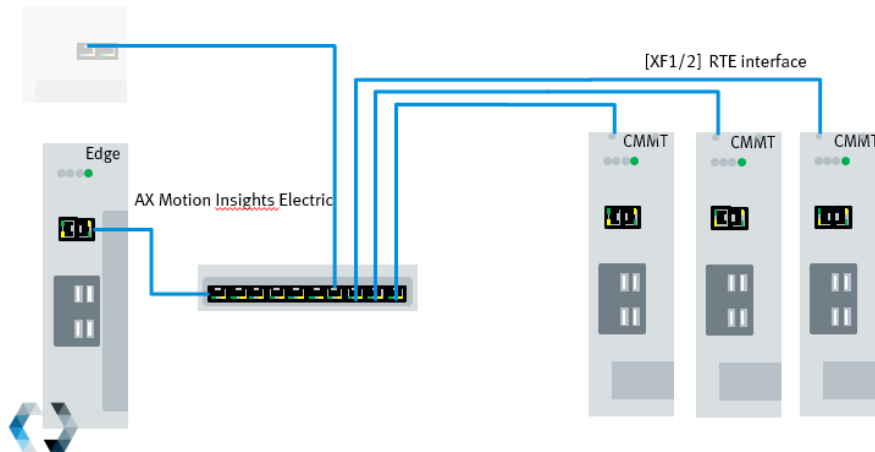

An Ethernet over EtherCAT (EoE) tunnel is required for the EtherCAT field bus. This must be powerful enough to transmit the data. Otherwise, you can use the connection to the X18 standard Ethernet port.

- Internet access

For retrieval of the industrial app “AX Motion Insights Electric” from Festo’s central container registry, temporary internet access is necessary. After installation, the internet access can be turned off.

### 2.2.3 Software / runtime environment

- Installed Docker runtime (OCI container)
- Support for Linux-Containers
- Docker-Compose v2.0
- WebUI: optimized for Webkit-based browsers and Firefox
- UI is optimized for a resolution of: 1024x768 or higher

## 2.3 Security/Intended Use

Festo AX Motion Insights Electric (AX MIE) is an industrial app, provided as a set of docker containers, for continuous monitoring of electric drive systems. Therefore, it gathers data from a Festo motor controller via proprietary Festo protocol, converts and streams the data over MQTT, analyses the data regarding anomalies of the connected electric drive system and persists the data and the results in a data storage (default a PostgreSQL database).

AX MIE is mainly designed to operate on shopfloor level on e.g. an edge computer inside an internal network with no permanent access to the public internet. If you choose to distribute the Docker container of MIE on different hosting systems or to operate MIE (partly) in a public cloud, please ensure to secure all communication channels like the MQTT broker with methods of authentication like username/password or certificates. Furthermore, keep in mind to restrict the access to the ports of the system via an appropriate firewall configuration (open only necessary ports and filter IP addresses for the access).

AX MIE is a recommendation system, that gives maintenance engineers insights about the health of the connected electric drive system. Therefore, AX MIE analyses data continuously by the use of algorithms from the field of machine learning. It is not recommended to automate an intervention in the control system of the machine based on analysis results from AX MIE.

### 3 Installation and Commissioning

To setup the entire AX Motion Insights Electric (AX MIE) industrial app, these steps have to be conducted:

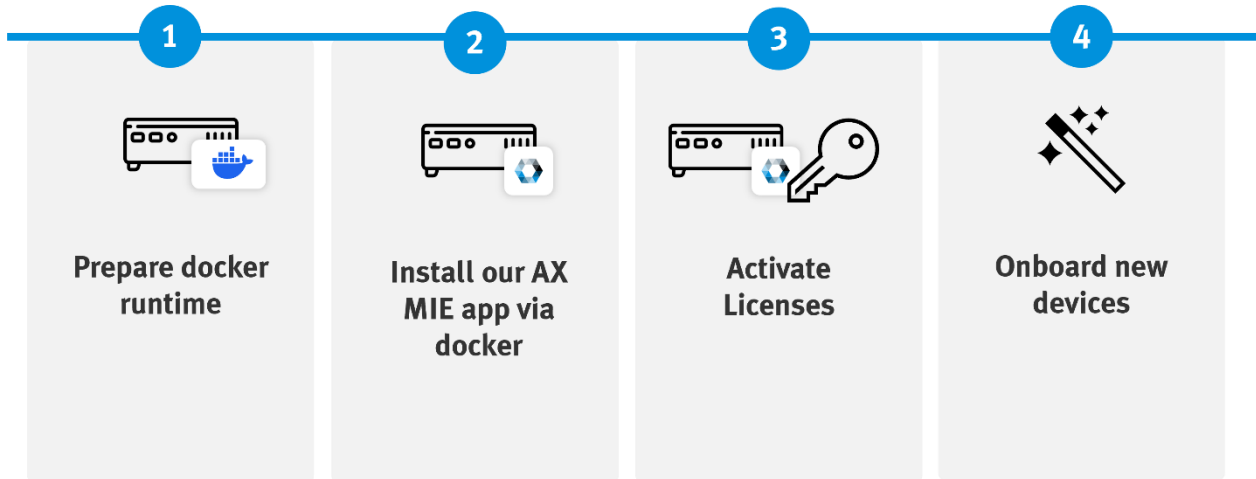

#### 3.1 Installation and setup of AX MIE containers

To learn more about “Container Applications” please refer to a google search and possible resources (last checked: Feb 2024):

Title	Author	URL
“Docker overview”	docker.com	<a href="https://docs.docker.com/get-started/overview/">https://docs.docker.com/get-started/overview/</a>
„Docker 101 Tutorial“	docker.com	<a href="https://www.docker.com/101-tutorial/">https://www.docker.com/101-tutorial/</a>
„Introduction to Docker containers“	Microsoft Learn	<a href="https://docs.docker.com/reference/cli/docker/image/save/">Introduction to Docker containers - Training   Microsoft Learn</a>
„Using tar archives to install offline“	docker.com	<a href="https://docs.docker.com/reference/cli/docker/image/save/">https://docs.docker.com/reference/cli/docker/image/save/</a> <a href="https://docs.docker.com/reference/cli/docker/image/load/">https://docs.docker.com/reference/cli/docker/image/load/</a>

Table 3.1: Tutorial links

The tutorials also explain on how to install a docker runtime on your preferred environment.

### 3.1.1 Provisioning of relevant information after purchase

After purchase an email is sent to the purchasing entity that includes all relevant information to fulfill the installation.

The email contains brief step-by-step instructions and links to all relevant document and most important setup and license files (“Download files” Link). Through this link a .zip is provided. It includes the following files:

Filename	Description
.env	File containing all relevant environment variables for the AX MIE instance, such as version, host name information, credentials. Besides other it is used by the docker-compose.yml to setup all containers accordingly. <b>Note:</b> Depending on local file explorer settings, this file might be hidden. Modifications to this file should only be made by knowledgeable persons.
docker-compose.yml	The docker-compose.yml file is a configuration file used in Docker to define and manage multi-container applications. It is used to specify the services, networks, and volumes required for AX MIE to run. The docker-compose.yml, defines the different containers in the AX MIE installation, their dependencies, and the configuration options for each container. <b>Note:</b> Modifications to this file should only be made by knowledgeable persons.
<uuid>-<package>-<nr>.lic	License file for each purchased AX MIE license. The number of .lic files in that package is equal to the number of licenses purchased through Festo online sales channel. The content of the license has to be copied to activate the license in one specific instance of AX MIE.
mosquitto.conf	File containing the configuration for the external facing MQTT broker that can be used to ingest data to Festo AX MIE. Additionally this MQTT broker can also be used to subscribe to the results of MIE. <b>Note:</b> Modifications to this file should only be made by knowledgeable persons.

Table 3.2: Files descriptions

### 3.1.2 Pre-Requisites to install and run AX MIE

AX MIE is provided as “docker container application”. To run AX MIE, e.g. on an Industry PC, “Docker” must be installed on the device/OS. Please refer to the provided information in chapter 3.1 or search for preferred and up-to-date installation instructions. This part is not covered in this application note.

It is highly recommended to also know about command line interaction, such as Bash or Windows PowerShell. For installation, the target device must be connected to the internet (to get the containers). After that, the internet connection can be disconnected again.

### 3.1.3 Retrieve container from Festo’s container registry

Upon purchase you receive an email with instructions and credentials to access our public container registry and retrieve (“download”) AX MIE containers.

The address of Festo AX’s container registry is:

**festoaxregistry.azurecr.io**

### 3.1.4 Authenticate / Login to registry

To authenticate to our registry a login command has to be executed. This authenticates the client to our public Festo AX container registry and allows for pulling of repositories and their stored container(s).

Insert on command line/terminal:

```
docker login -u <user> -p <password> festoaxregistry.azurecr.io
```

The credentials to <user> and <password> are automatically sent after purchase of AX MIE through our online sales channel, e.g. Festo App World. If not available to reader of this document, get in contact with the people that performed the purchase through our online sales channel.



#### Note

- **In case you can not access this registry, check the firewall settings according to <https://learn.microsoft.com/en-us/azure/container-registry/container-registry-firewall-access-rules>**

### 3.1.5 Start with docker compose file

The docker compose file is also attached to the after sales email and is the central setup file to retrieve all containers and set them up in the correct order and configuration. It is configured as an easy-to-use setup. It can be edited and adjusted to individual needs. Note: Modifications to this file should only be made by knowledgeable persons.

Open up a command interface and navigate to the directory where the docker-compose.yml is stored.

To start the application enter the following command. Upon first execution or after version changes in the docker compose file, the containers are retrieved from the central repository and installed locally.

Insert on command line/terminal:

```
docker compose up
```

To stop the container from running again, enter the following command:

Insert on command line/terminal:

```
docker compose down
```

### 3.1.6 Version update

If there is a new version released, the update procedure only needs a docker compose down, change of the version tag at the beginning of the .env file and run docker compose up again like described in 3.1.5:

```
##BEGIN OF COMMON SECTION  
# Version of the Containerset  
VERSION=xx.y.zz
```

### 3.2 Initial Setup: user creation and license activation

To work in the main application browse to <ip-address> without any additional port information (it uses standard http port 80).

During startup, you will be asked to create initial user accounts for Superadmin and Admin:

The screenshot shows the 'Festo Automation Experience' setup interface. At the top, there is a progress bar with three steps: 'Superadmin Account' (completed), 'Admin Account' (current step), and 'License' (pending). Below the progress bar, the text reads: 'Set up of admin user account. Please provide a user name, email and password. More users can be invited later.' The form includes fields for 'Name \*', 'Email \*', 'Password \*', and 'Repeat password \*'. Below the password fields, there is a list of password requirements:

- One lowercase character or more
- One uppercase character or more
- One number or more
- One of these special characters or more #!@%\$%^&\*+~\_
- 8 characters minimum

At the bottom right, there are 'Back' and 'Next' buttons.

In the next step you will be asked for a license key. License keys are provided as files through the after sales email that redirects to the setup package of files.

The license files (.lic) include the license key string that is needed to activate a license in one AX MIP instance. Therefore paste the content of your license file (\*.lic) into the form:

The screenshot shows the 'Festo Automation Experience' setup interface. At the top, there is a progress bar with three steps: 'Superadmin Account' (completed), 'Admin Account' (completed), and 'License' (current step). Below the progress bar, the text reads: 'Set up license to activate Festo AX.' The form includes a large text area labeled 'License \*' for pasting the license key. At the bottom right, there are 'Back' and 'Save' buttons.

Further licenses can be added later according chapter 3.3.

### 3.3 Additional licenses

To activate further licenses, please navigate to “Admin Setup” > “Licenses”

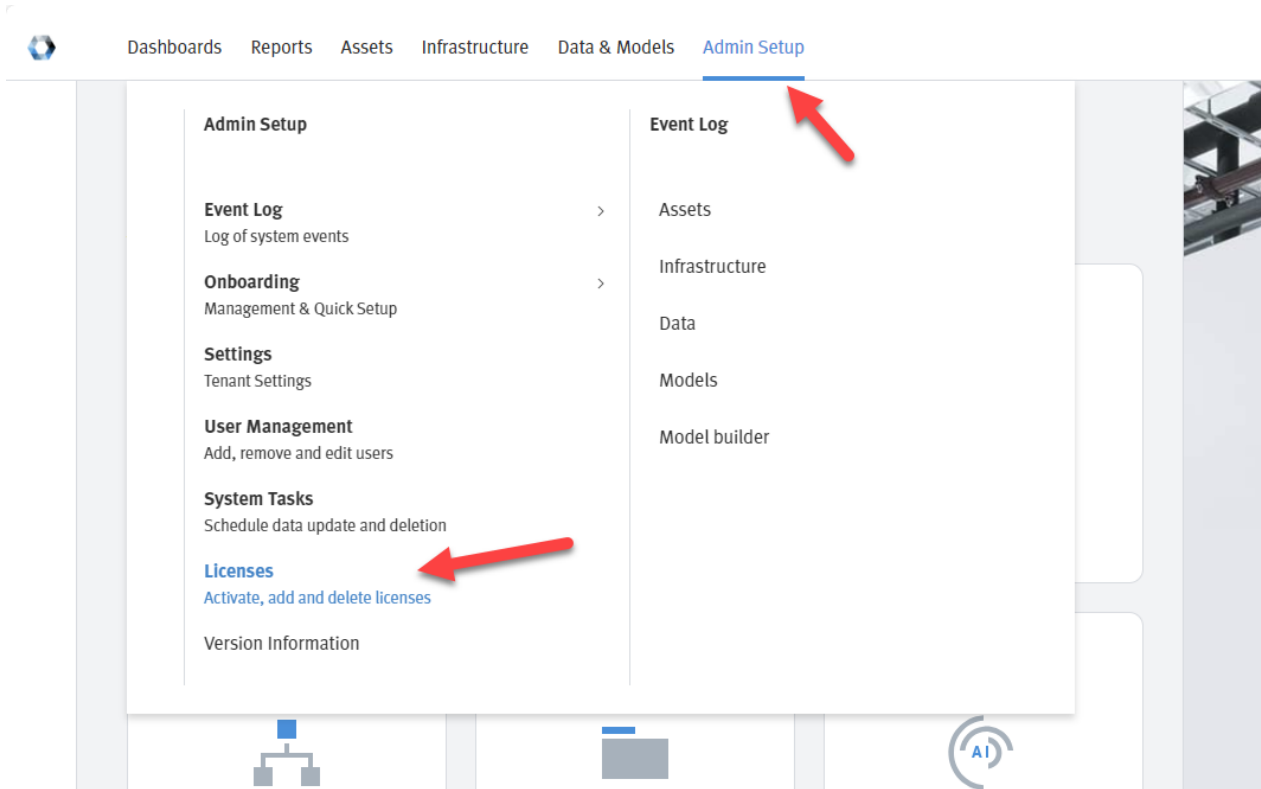

You will be in the license overview page:

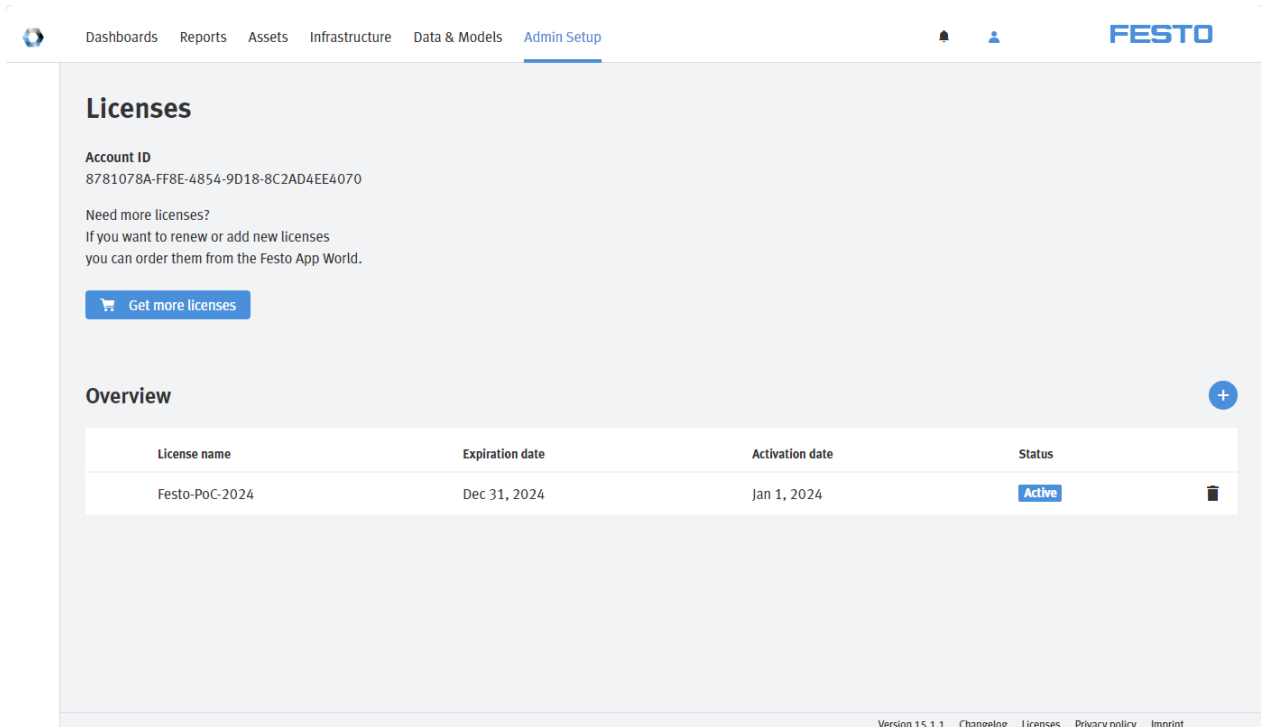

This gives you an overview of the already activated licenses. Furthermore, once assets are onboarded, you will also see the number of already onboarded assets (and the number of licenses left).

By clicking on the (+) button, one can add new licenses to the instance. Therefor paste the content of one your license files (\*.lic) into the form:

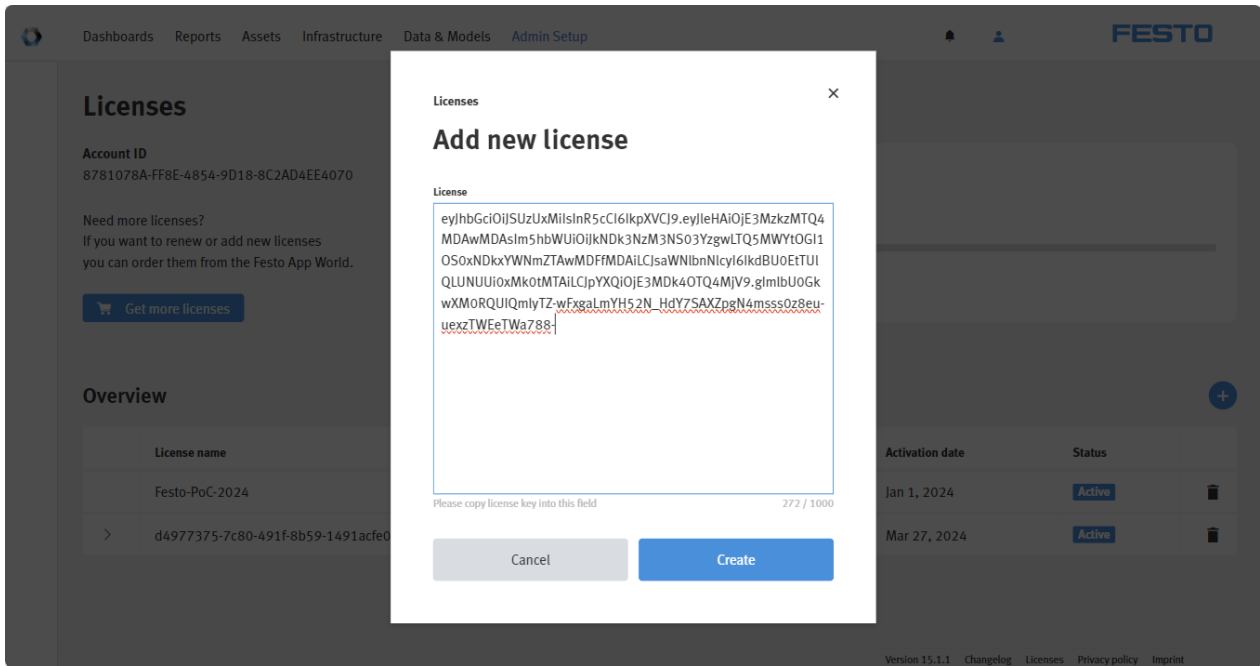

The license is then added to the instance. Further assets can be onboarded then!

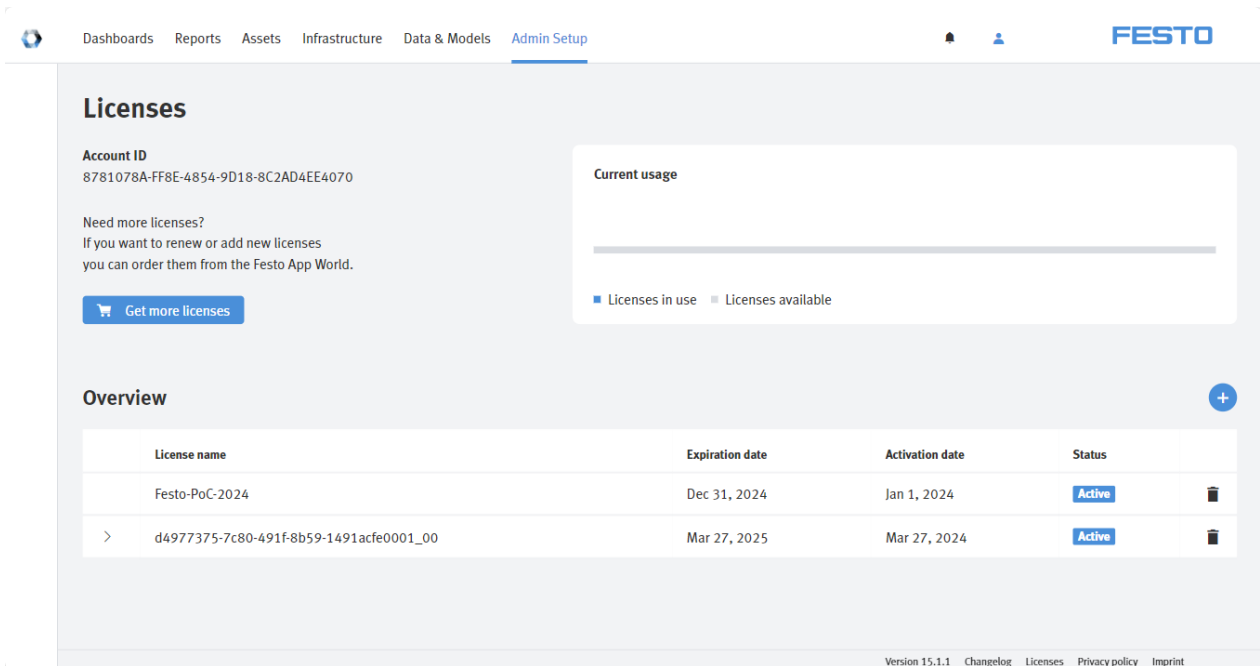

## 4 Onboarding of Assets

### 4.1 Automatic Onboarding

To establish the connection to AX MIE, you only need to put in the IP address of the motor controller in our connectivity solution “AX Data Access”.

Browse to <ip-address> :4444 on your AX MIE installation. The connectivity solution “AX Data Access” opens up.

Click on “Devices/ Manage Devices”

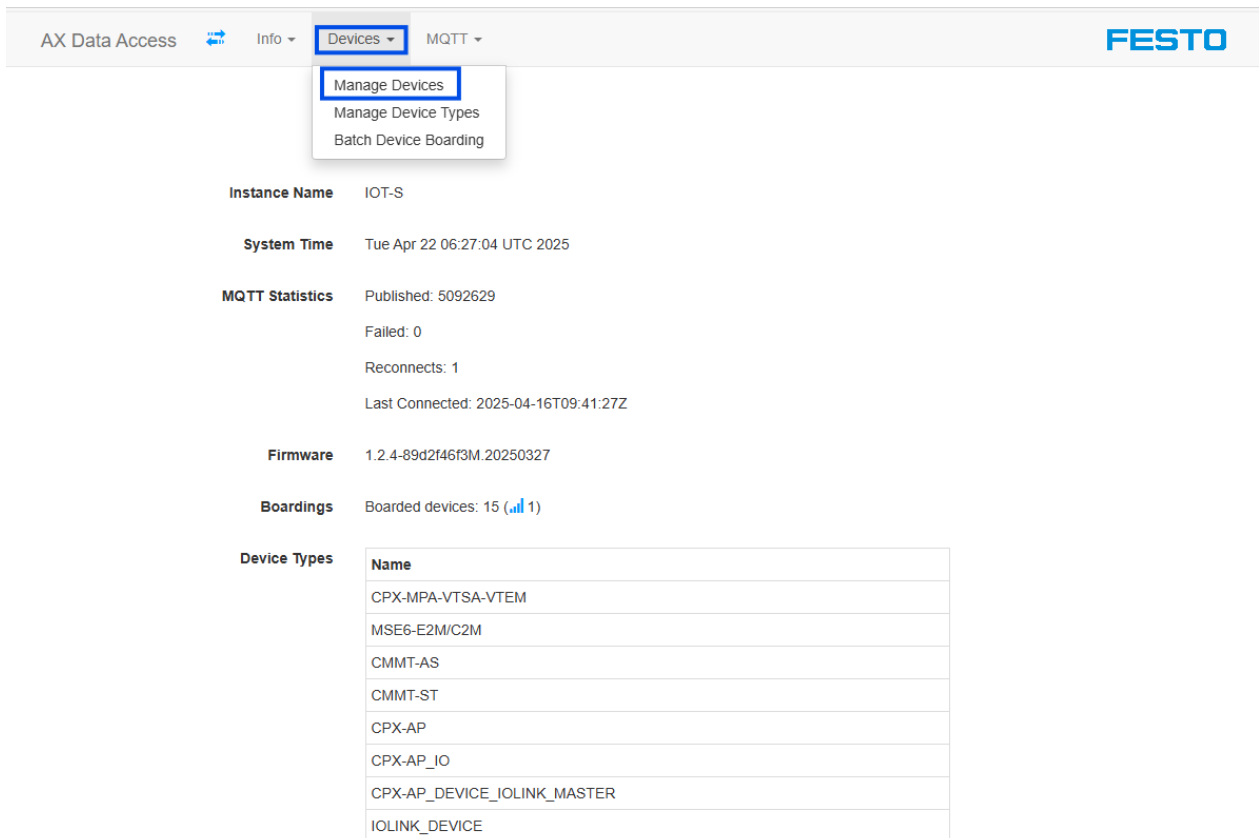

The screenshot shows the AX Data Access web interface. At the top, there is a navigation bar with 'AX Data Access', 'Info', 'Devices', and 'MQTT'. The 'Devices' dropdown menu is open, showing options: 'Manage Devices', 'Manage Device Types', and 'Batch Device Boarding'. Below the navigation bar, the main content area displays system information:

- Instance Name:** IOT-S
- System Time:** Tue Apr 22 06:27:04 UTC 2025
- MQTT Statistics:** Published: 5092629, Failed: 0, Reconnects: 1, Last Connected: 2025-04-16T09:41:27Z
- Firmware:** 1.2.4-89d2f46f3M.20250327
- Boardings:** Boarded devices: 15 (all 1)
- Device Types:** A table listing device names: CPX-MPA-VTSA-VTEM, MSE6-E2M/C2M, CMMT-AS, CMMT-ST, CPX-AP, CPX-AP\_IO, CPX-AP\_DEVICE\_IOLINK\_MASTER, and IOLINK\_DEVICE.

Put in the IP address of the CMMT motor controller and press the “Scan” button.

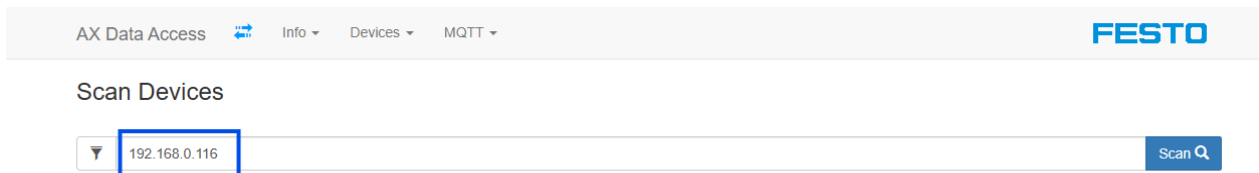

The screenshot shows the AX Data Access web interface with the 'Scan Devices' section. The 'Devices' dropdown menu is open. Below it, there is a text input field containing the IP address '192.168.0.116'. To the right of the input field is a blue 'Scan' button with a magnifying glass icon.

Click on the “Board” button.

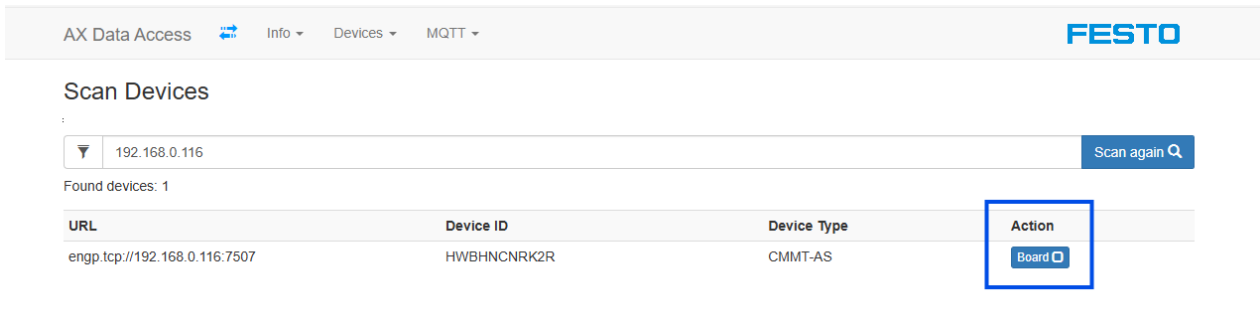

You can now specify the name of the node in the asset tree in the “Topic Prefix” input field. The default value is “machineGroup1”. The root node is always “MIE”.

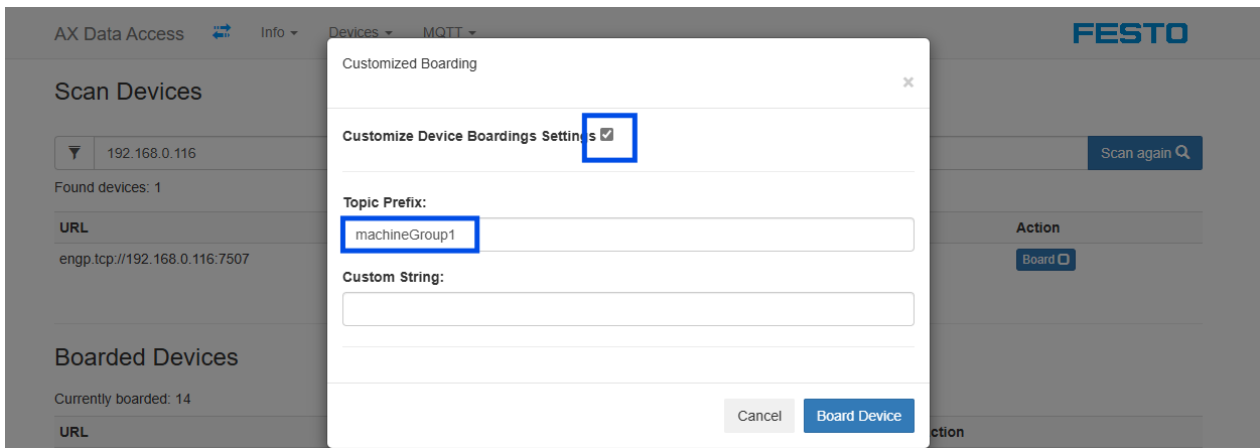

You have now successfully boarded the device. The MQTT connection is preconfigured and the blue symbol indicates a successful MQTT connection.

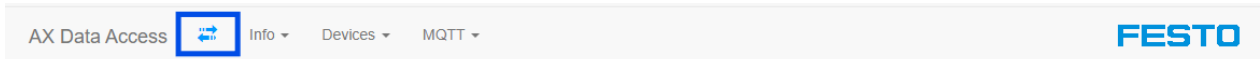

Open Festo AX MIE: Browse to <ip-address> on your AX MIE installation. You will see the new onboarded devices in the asset tree as previously defined.

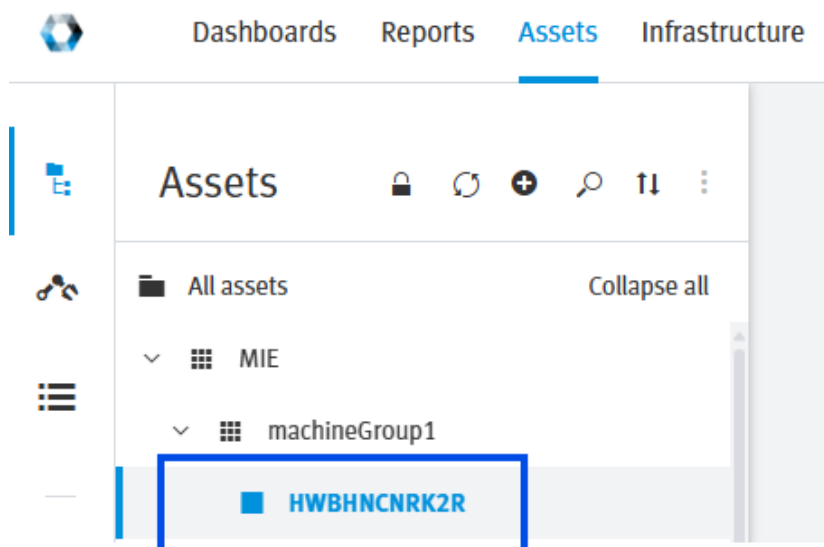

## 4.2 Manual offboarding / deletion of assets

In case there are assets, that you don't need to monitor anymore, they have to be deleted in the AX MIE UI manually.

Make sure, that you also offboard the according device in AX Data Access (see 4.1), otherwise the asset will be auto-onboarded again.

### Boarded Devices

Currently boarded: 1

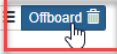
URL	Device ID	Device Type	Action
engp.tcp://192.168.0.110:7507		CMMT-ST	Info ⓘ Config ⋮ <b>Offboard</b> 

Next turn on edit mode of the asset tree, then delete the assets via right click on the context menu of each assets bottom up.



#### Note

- For versions > 22.x.x the asset tree is in read-only mode by default. To make it editable, deactivate the feature toggle “Asset Tree Read Only” when logged in with the superadmin account (see chapter 3.2)

By deleting the assets, the according license will be released then.

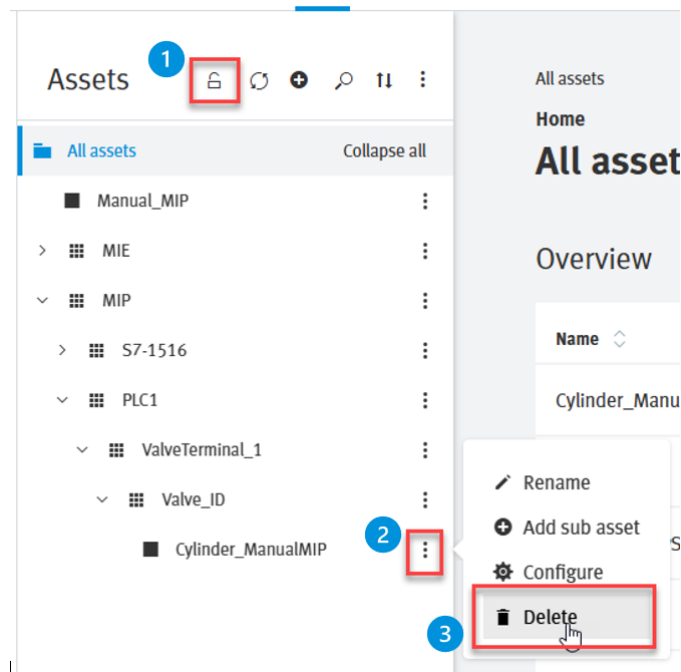

### 4.3 Initial Training

Before the anomaly detection is active, a first initial training has to be finished. Therefore a scheduled training is configured by default. You can check the progress in the asset settings.

AX MIE needs at least 200000 “good” data points for initialization. “Good” means, the electric drive system must be in a good condition working in its usual behavior. This is the “baseline” for the ongoing anomaly detection.

The screenshot displays the configuration interface for asset HWBHNCNRK2R-25. It features a 'Models' table with columns: No., Model name, Type, Format, Sample size, Current version, Linked Model, Active, and Status. Three models are listed, with the third model, 'HWBHNCNRK2R-25-MIE', selected. Below this, the 'Scheduled trainings' tab is active, showing a table with columns: Model name, Status, Next run, Recording progress, and Stop date. The recording progress bar indicates 158811 of 200000 samples collected.

### 4.4 Model-Finetuning

The machine learning model has two main hyper-parameters “Tolerance” and “Sensitivity”. The default values are well chosen. Start with the default values and only adjust them if you are not satisfied with the results.

Hyper-Parameter	default	Too many false positives	Too many false negatives
Sensitivity	60	50	70
Tolerance	6	7	5

Table 4.1: Parameter finetuning values

False positives mean that an anomaly was reported but did not exist.

False negatives mean that an anomaly has been missed.

To retrain an existing model with new hyper-parameters you can do the following steps.

- Open the 3rd model of the asset and configure a “Scheduled training”

Configuration  
**HWBHNCNRK2R-6**

Resume Pause & Edit

Models

No.	Model name	Type	Format	Sample size	Current version	Linked Model	Active	Status
1	MIE-Pre	Anomaly detection	Custom Java Model	-	v1 (Mar 20, 2025, 13:12:41)		On	✓
2	MIE-Filtering	Anomaly detection	Custom Java Model	-	v1 (Mar 20, 2025, 13:12:41)	HWBHNCNRK2R-6-MIE HWBHNCNRK2R-6-MIE-Post	On	✓
3	HWBHNCNRK2R-6-MIE	Anomaly detection	Custom Java Model	99995	v1 (Apr 3, 2025, 20:01:02)	HWBHNCNRK2R-6-MIE-Post	On	✓

Feature mapping Output features Thresholds **Scheduled trainings**

No scheduled model trainings active

- Set the “Datasamples” and the hyper-parameters and click “ok”

Model: HWBHNCNRK2R-6-MIE

### Add scheduled retraining

Datasamples: 200000 Scheduler stop date: May 23, 2025 Scheduler stop time: 9:22

Advanced settings

Model activation

Workflow

Algorithm	AUTO
Random Seed	-1
Sensitivity	50
Tolerance	7

Cancel Ok

## 5 When the application is running

### 5.1 UI Walkthrough

After logging into the application, the user is greeted with the app's start screen. As user with the role "ADMIN", the start screen looks as following:

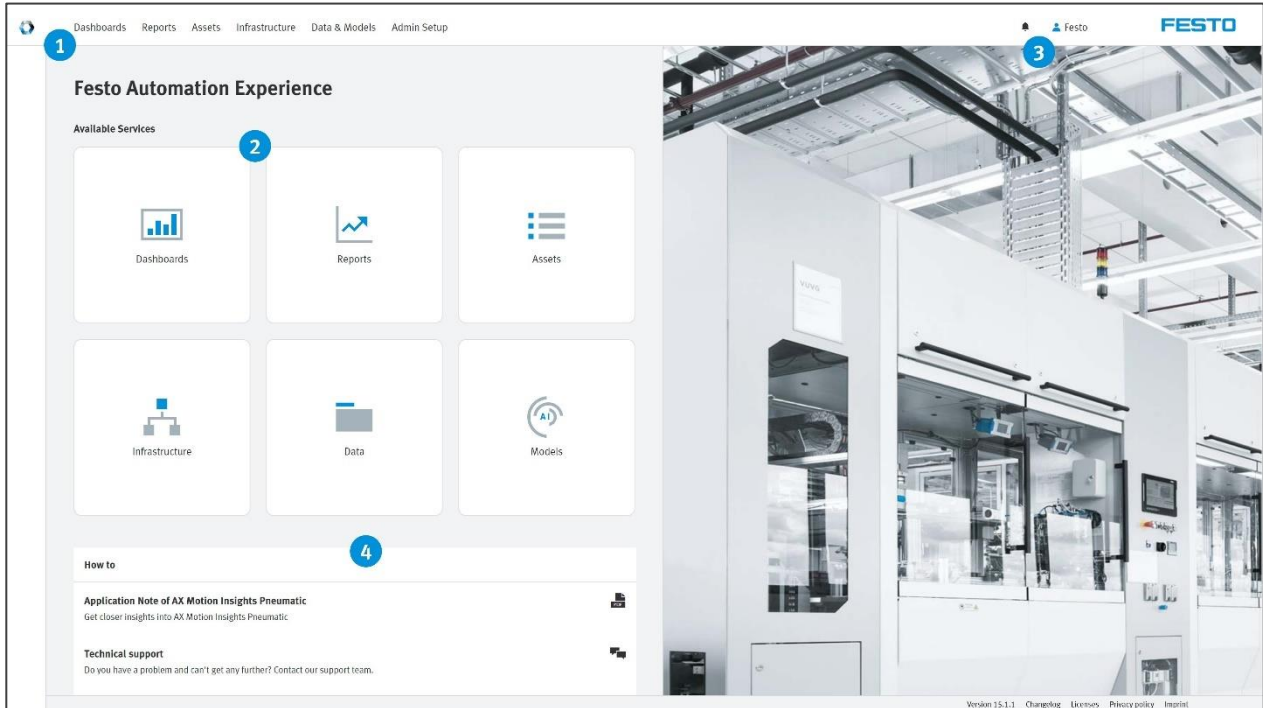

When the application is running

### 5.1.1 Main Menu (1)

On the top you'll find the main menu starting from the left, that will bring you to the sub sections of the app. It includes:

Menu point	Description	Remark
Dashboards	Access to build customized dashboards from a selection of widgets with the data coming from onboarded assets with their data points/features.	Only users with ADMIN role
Reports	Access to reports to get dedicated views on events and data in retrospective. First report is "Hierarchical Report" to gain overview of anomalies that have occurred in a specific time range.	All users
Assets	Access to all onboarded assets (here: pneumatic cylinders) with their dedicated dashboards for each asset for live view on the asset state.  An asset tree allows for easy navigation in hierarchical structure.	All users
Infrastructure	Expert setting screen to adjust inbound and outbound MQTT broker and other settings.	Only users with ADMIN role
Data&Models	Expert setting screen to work with data sets and trigger new trainings on models.	Only users with ADMIN role
Admin Setup	Access to event log, onboarding settings, general tenant settings, user management and system settings.  Furthermore access to license settings to activate new licenses and gain overview about existing license setting.	Only users with ADMIN role

Table 5.1: Menu descriptions

### 5.1.2 Quick Access Buttons (2)

The buttons copy the functionality from the main menu for fast access.

### 5.1.3 Notifications and User Profile (3)

The bell icon gives you access to the notification dialog. Here users will be notified about two types of events:

1. Anomaly events
2. Onboarding events

**Anomaly events:** All anomaly events that occur on the onboarded assets are being triggered as a notification and shown here for direct access.

**Onboarding events:** Once a new asset has been onboarded to the application, a notification is triggered and shown here. This is especially helpful in the onboarding process.

## 5.2 Asset Dashboard Walkthrough

Clicking on “Assets” guides you to the assets section that represents one of the core parts of the application. This section gives you structured access to the live data for all onboarded assets.

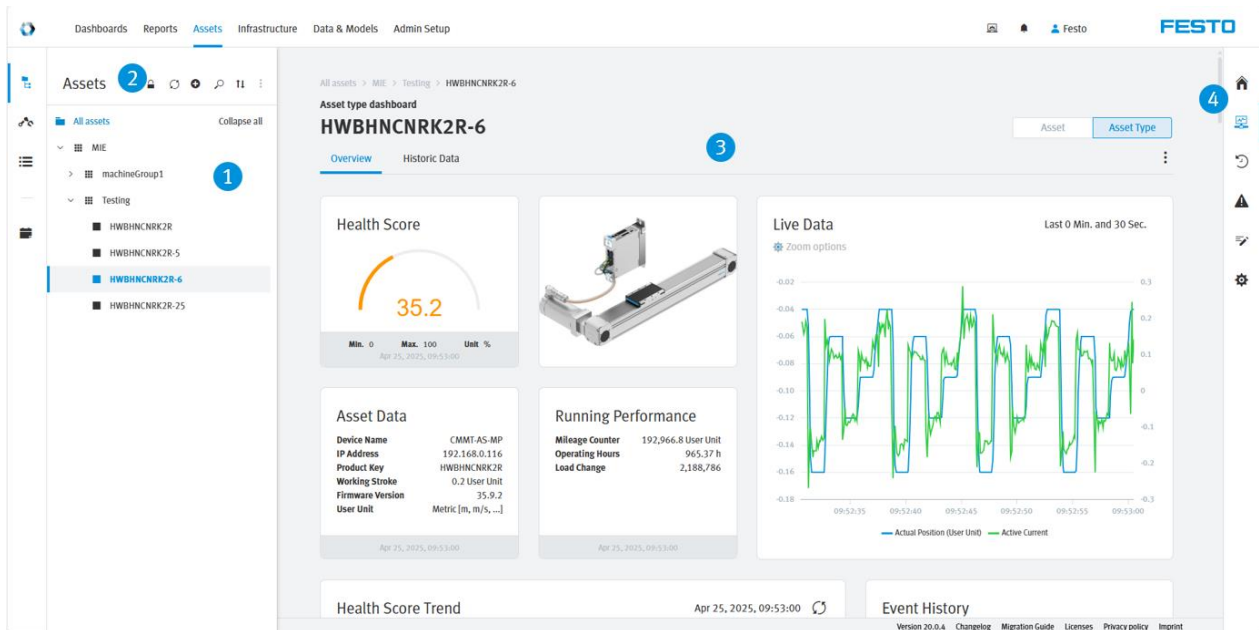

### 5.2.1 Asset Tree (1)

The asset tree represents the hierarchical structure of your monitored machine or subsystem. Clicking on the asset name will bring you to the detail screen for the asset.

### 5.2.2 Asset Tree Controls (2)

These buttons allow you to turn on the edit mode for the asset tree (to modify it), to reload its structure (can be helpful in onboarding phase), to create new assets or to search for a specific one (helpful in scenarios with many assets).

### 5.2.3 Asset Main Screen (3)

The main screen section displays the respective sub menu content that is selected through the sub menu on the right side. For example: it contains the dashboard section for an asset when “Dashboard” is selected on the right side.

When the application is running

### 5.2.4 Asset Tree Controls (4)

The sub menu on the right side controls section to show for the asset selected by the asset tree.







Icon	Descriptions
	Home Screen for the asset. Contains an overview including the current health score for the asset (or group of assets when a node is selected in the tree).
	<b>The dashboard for the asset.</b> There is two sections: the general dashboard that is derived from the asset's asset type and a dashboard for the individual asset. The latter can be designed individually by the user. The first one gives a great overview and already contains a lot of information about the current state of the asset as well as a look back for a certain time period.
	Access to historic data of the asset. Further offers to export the data selection as csv or to create a new data set in AX from it to train a model with it.
	Event log for an asset. Here all events for the asset, such as anomalies, are collected.
	Upon anomalies, annotation can be added to an event to use in future events.
	Model overview for an asset. Allows for fine tuning of a model and to schedule new trainings, e.g. after component replacement. Expert section.

Table 5.2: Icon descriptions

## 5.3 Inviting New Users

User with role "ADMIN" can invite new users. There is currently no logical limit to users added to the application. New users are added through the "Users" screen. It is reached through

Admin Setup > User Settings > (+) *New User*

Three things are needed for a new user:

- Name: a non-unique name to label the user
- FestoAX-ID: E-Mail address to uniquely identify user (also used for login)
- Password: The password to authenticate the user.

The new user can be set to "read-only". This allows for accounts that can only view the data but not make amendments.

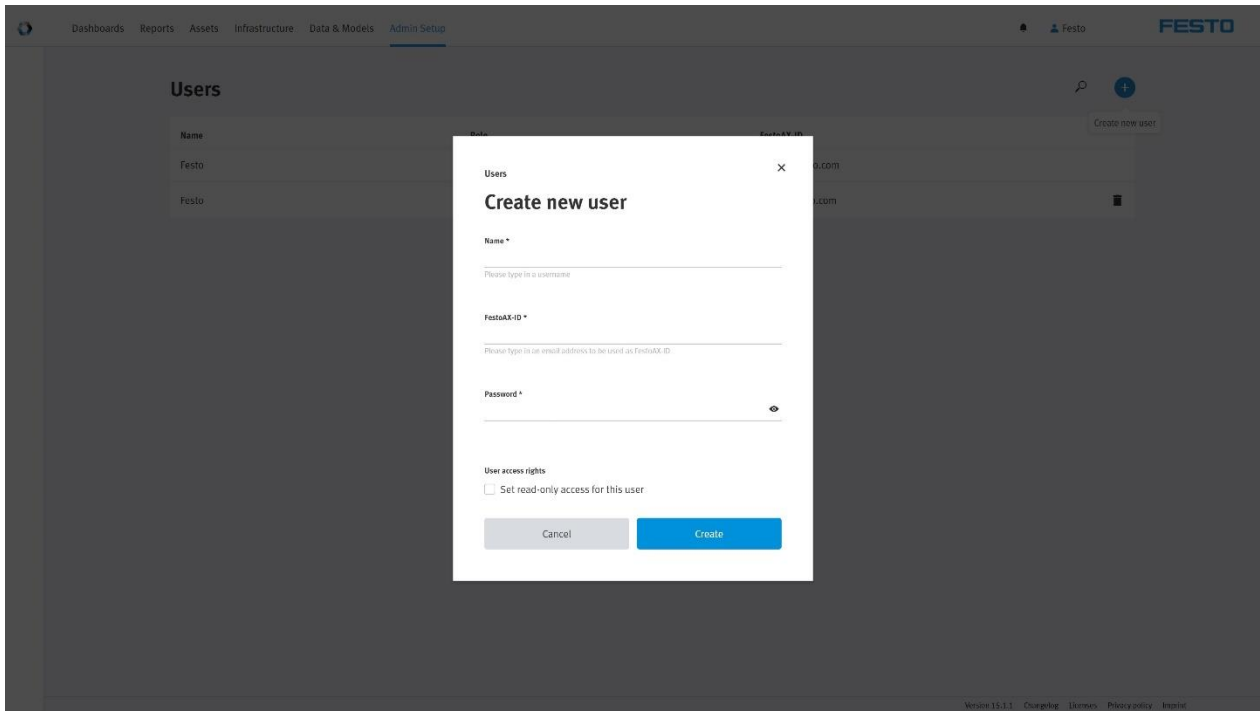

## 5.4 Outbound MQTT Data Delivery

To use model results like anomaly score or anomaly event in 3<sup>rd</sup> party systems, an outbound connection via MQTT can be configured. It is reached through

Infrastructure > Field > Outgoing data > Default Datadelivery > (+) *New Component*

The same broker like for the incoming data, which is part of the docker-compose.yml, can be used:

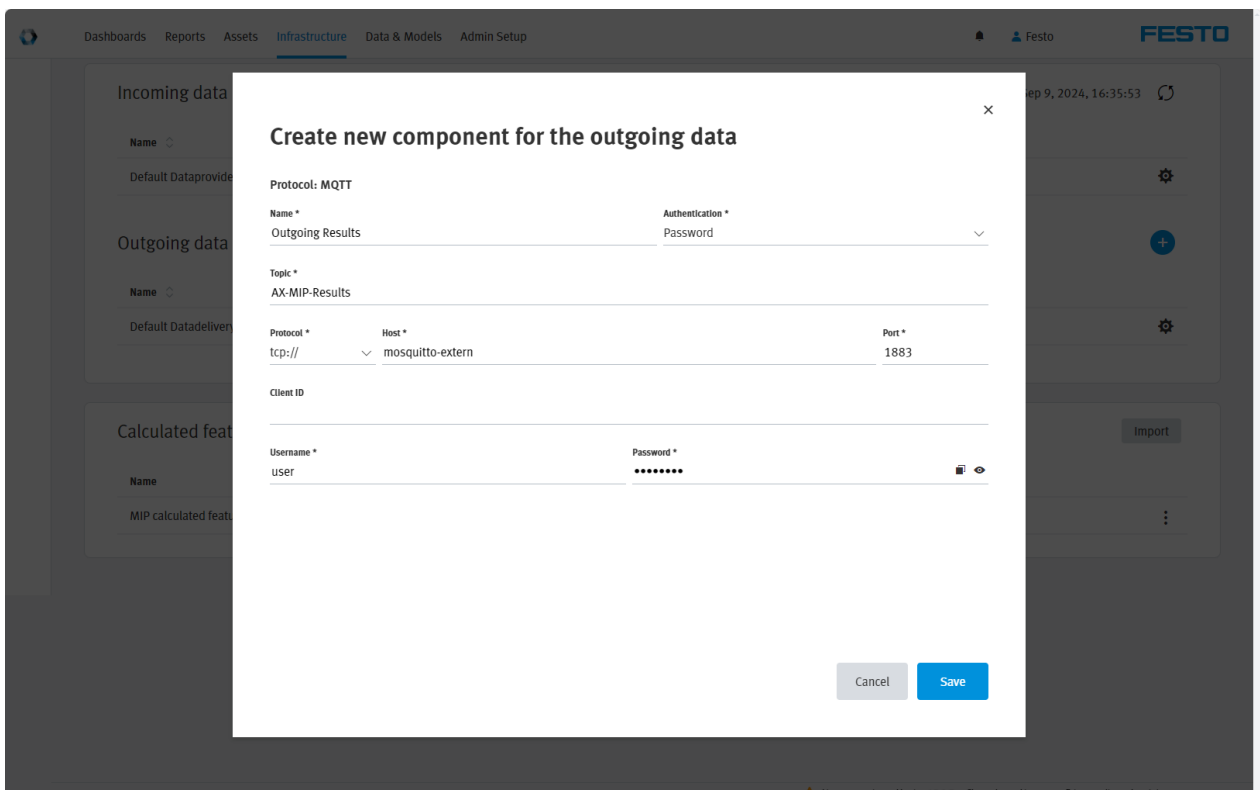

When the application is running

To get results being sent out, the “Field to External (F2E)” forwarding gate has to be activated for the features needed:

- For the according asset, choose the settings and pause the anomaly detection model (MIE-Post):

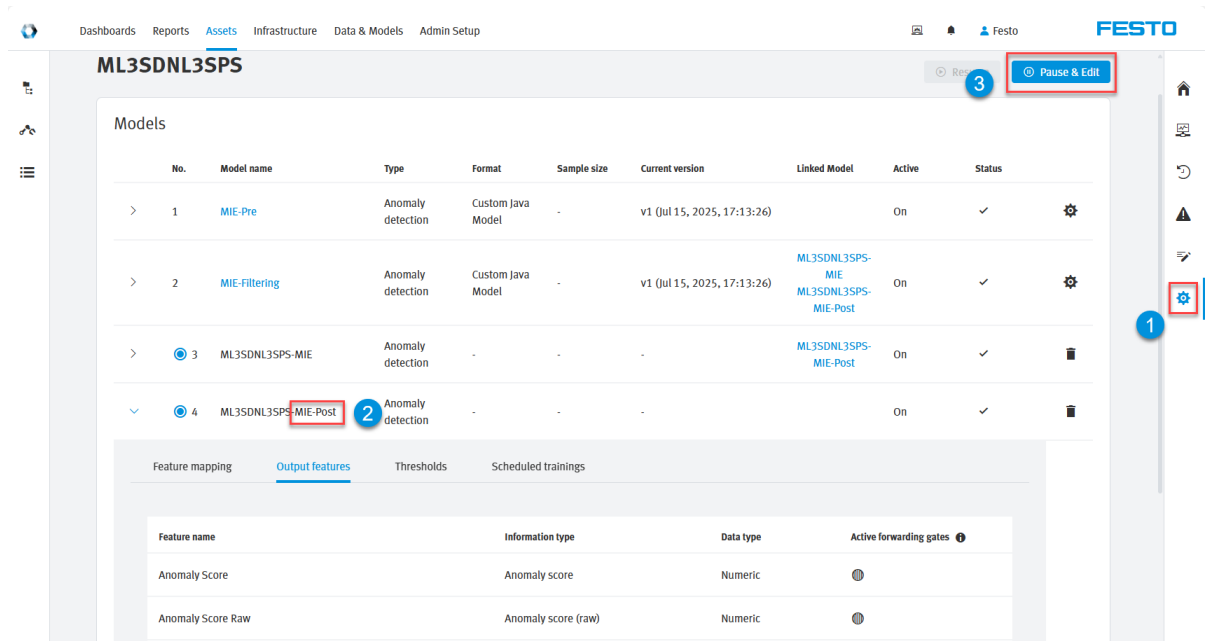

- After pausing the model, the forwarding gates can be adjusted and the anomaly detection model can be resumed:

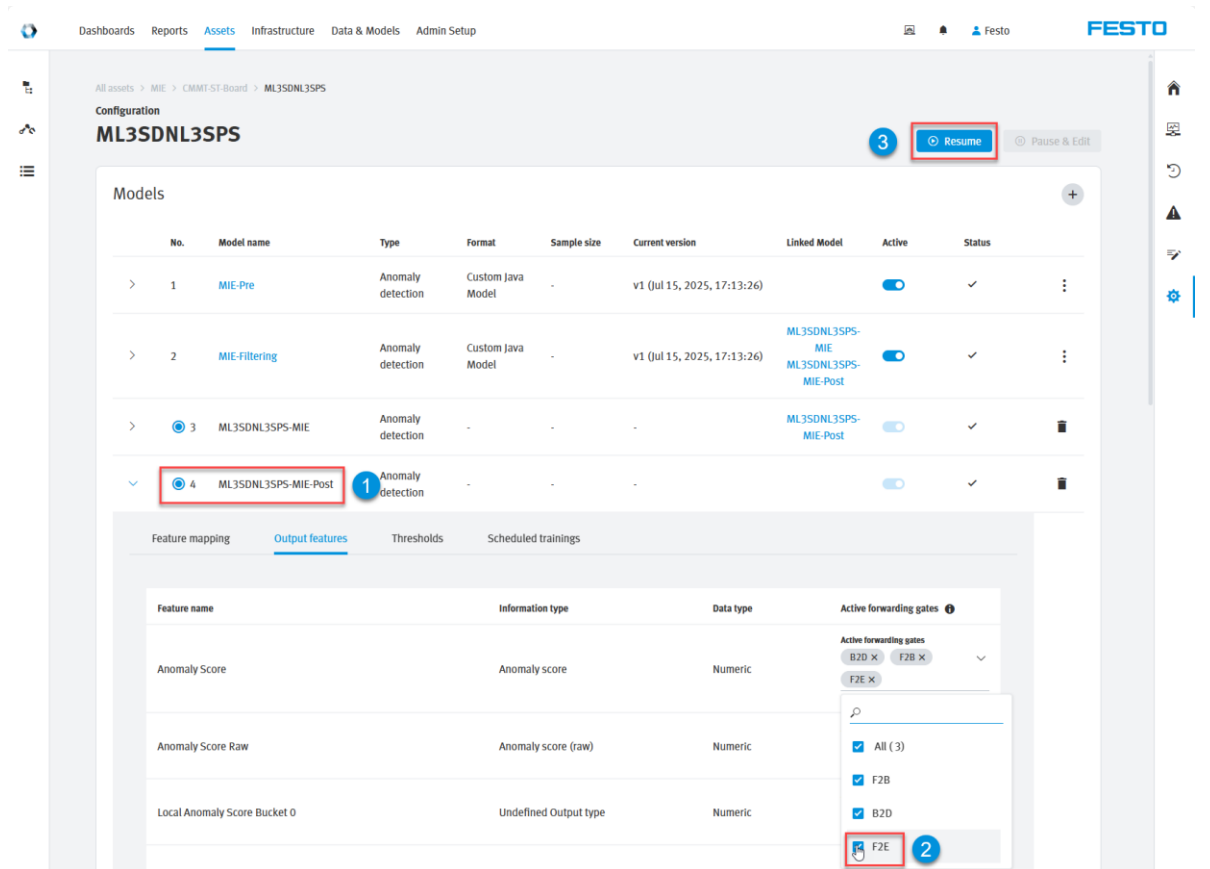

## 5.5 Connecting Festo AX Smartenance

To be able to trigger incidents for specific assets, a premium account for Festo AX Smartenance is needed. Then the API credentials to connect both systems can be added in Festo AX Motion Electric Insights here:

Admin Setup > Settings > Smartenance

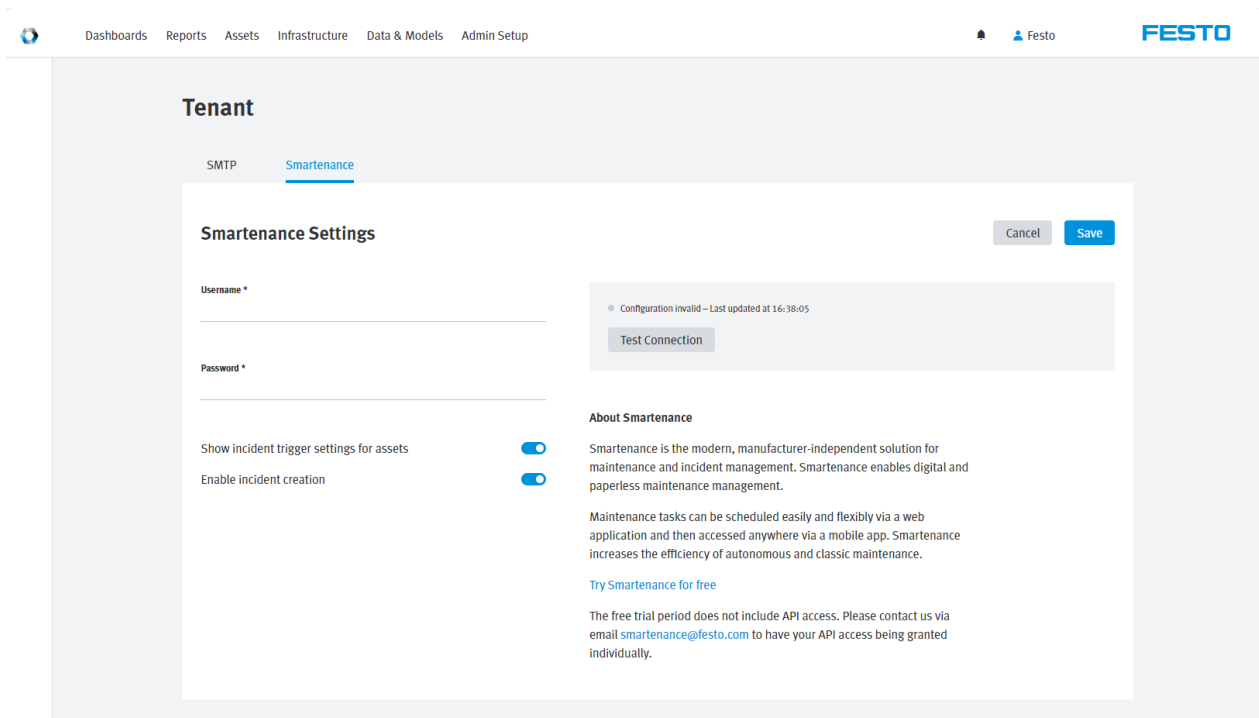

After establishing the connection, each asset can be configured to trigger an according incident in Smartenance:

Asset Tree Controls > Asset configuration > Maintenance system triggers > (+) *Add maintenance trigger*

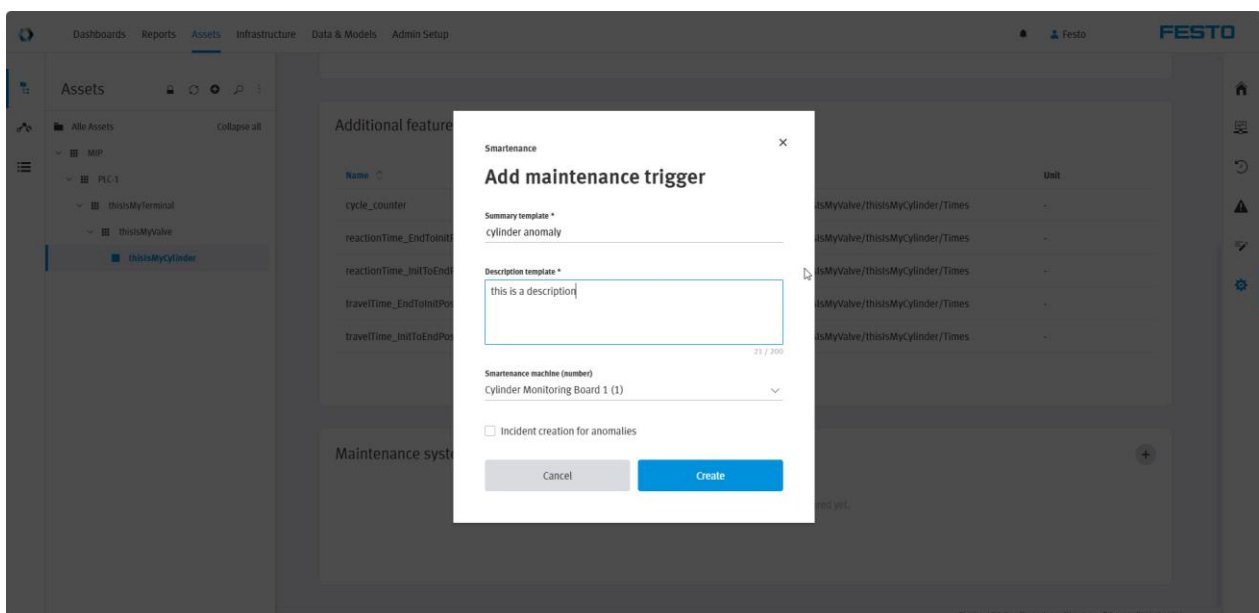

When the application is running

## 5.6 Deletion of data

Recorded data is deleted by 90 days as a default deletion task. This can be changed by adding a new task and deleting the existing default task:

Admin Setup > System Tasks

## 5.7 Debugging: System Info / Status

In case of any unexpected behaviour, the status of connectivity etc. can be checked in the connectivity solution “AX Data Access”.

### MQTT Connection State

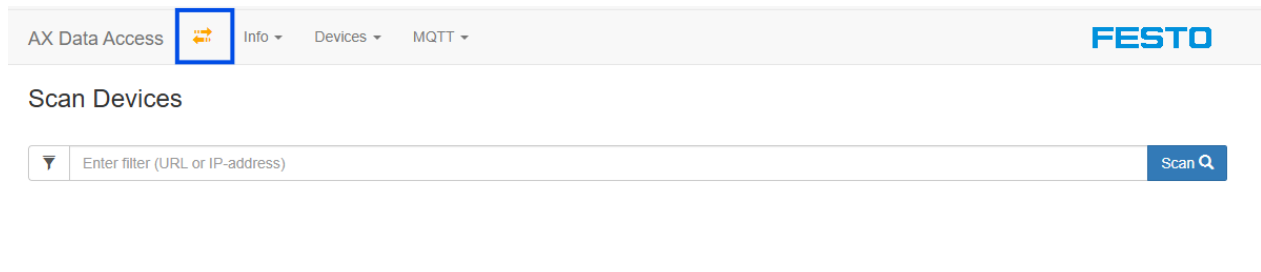

### MQTT Statistics

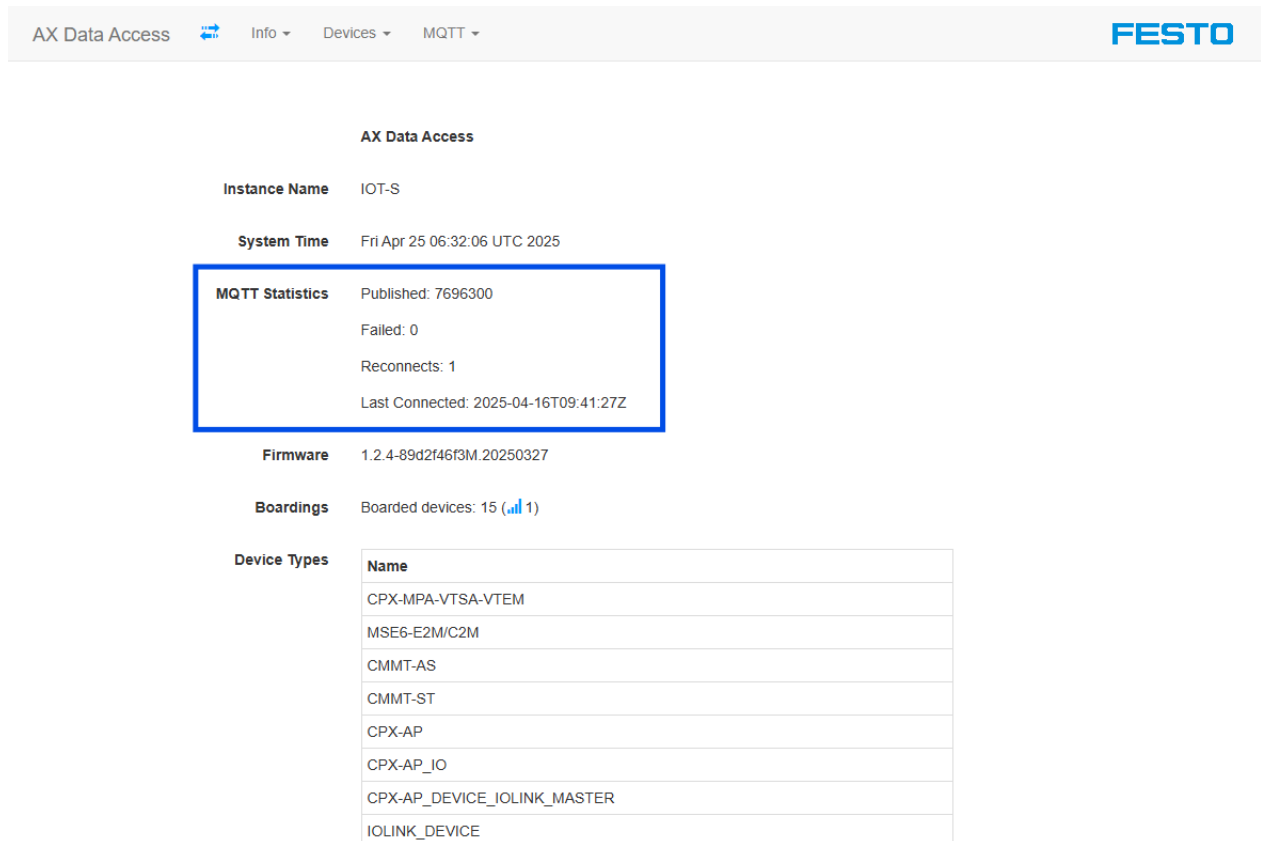

**AX Data Access**

**Instance Name** IOT-S

**System Time** Fri Apr 25 06:32:06 UTC 2025

**MQTT Statistics** Published: 7696300  
Failed: 0  
Reconnects: 1  
Last Connected: 2025-04-16T09:41:27Z



**Firmware** 1.2.4-89d2f46f3M.20250327

**Boardings** Boarded devices: 15 (1)

**Device Types**

Name
CPX-MPA-VTSA-VTEM
MSE6-E2M/C2M
CMMT-AS
CMMT-ST
CPX-AP
CPX-AP_IO
CPX-AP_DEVICE_IOLINK_MASTER
IOLINK_DEVICE

## Device Connection State





























































AX Data Access  Info  **Devices**  **FESTO**

### Scan Devices

 Enter filter (URL or IP-address) **Scan** 

### Boarded Devices

Currently boarded: 15

URL	Device ID	Device Type	Action
engp.tcp://192.168.103.13:7507	 3S7PMD240S6	CMMT-AS	  
engp.tcp://192.168.103.16:7507	 3S7PMD240TQ	CMMT-AS	  
engp.tcp://192.168.103.15:7507	 3S7PMD240X8	CMMT-AS	  
engp.tcp://192.168.103.18:7507	 3S7PMD240YS	CMMT-AS	  
engp.tcp://192.168.103.14:7507	 3S7PMD240Z9	CMMT-AS	  
engp.tcp://192.168.103.17:7507	 3S7PMD24123	CMMT-AS	  
engp.tcp://192.168.103.19:7507	 3S7PMDGD6QJ	CMMT-AS	  
engp.tcp://192.168.103.25:7507	 3S7PMDGD6R1	CMMT-AS	  
engp.tcp://192.168.103.22:7507	 3S7PMDGD6T2	CMMT-AS	  
engp.tcp://192.168.103.21:7507	 3S7PMDGD6Y4	CMMT-AS	  
engp.tcp://192.168.103.26:7507	 3S7PMDGKXJR	CMMT-AS	  
engp.tcp://192.168.103.20:7507	 3S7PMDGKXLS	CMMT-AS	  
engp.tcp://192.168.103.24:7507	 3S7PMDGKXM9	CMMT-AS	  
engp.tcp://192.168.0.70:7507	 B2MCNTXJ0KJ	CMMT-ST	  
engp.tcp://192.168.0.54:7507	 HWBHNCNRK2R	CMMT-AS	  

## 6 Frequently Asked Questions

➤ **How many cycles do I need to fine-tune the model initially?**

200000 data points are needed to fine-tune the model. These cycles should include all possible variants of the process (e.g. different weights or movements).

➤ **What actuators does AX Motion Insights Electric work for?**

It works for linear actuators with a belt or spindle that perform cyclic movements. It does not work for a completely random movements.

➤ **Can I install Motion Insights Electric to an existing installation or do all the actuators have to be new at start up?**

Motion Insights Electric can be installed on existing, running installations as well as new ones. The electric drive system should be in good condition and running optimally.

➤ **What happens to the monitoring when an actuator is replaced by a new one?**

You need to retrain the AI for 200000 datapoints to re-establish norms.

➤ **Does AX Motion Insights Electric work with non-Festo electric drive system?**

The model is capable to monitor a wide variety of electric drive systems. To realize the best possible user experience, the connectivity is specially tailored to Festo CMMT motor controllers. If you would like to monitor a non-Festo drive, please contact our sales team.

➤ **I have specific questions. How can I get in contact?**

Get in contact with your Festo contact person or through [www.festo.com/contact](http://www.festo.com/contact)

➤ **The machine is running but I don't see any data or anomaly score calculated. What is the reason?**

There's different reason why no anomaly score is calculated and no data received although everything seems to be set up correctly and machine is running.

- Check MQTT status
- Check MQTT statistics
- Check Device connection status