

# Basic Motor Control Technology

Original Operating Instructions

**FESTO**

Electric Power Technology

User Guide



Festo Didactic

en

8174388

**Electric Power Technology**

**Basic Motor Control Technology**

**Original Operating Instructions**

**User Guide**

8174388

Order no.: 8174388 (Printed version) 8174389 (Electronic version)  
First Edition 2022/03  
Revision level: 2025/09

By the staff of Festo Didactic

© Festo Didactic Ltée/Ltd, Quebec, Canada 2022

Internet: [www.festo.com](http://www.festo.com)

e-mail: [services.didactic@festo.com](mailto:services.didactic@festo.com)

Printed in Canada

All rights reserved

ISBN 978-2-89834-142-7 (Printed version)

ISBN 978-2-89834-143-4 (Electronic version)

Legal Deposit - Bibliothèque et Archives nationales du Québec, 2022

Legal Deposit - Library and Archives Canada, 2022

The purchaser shall receive a single right of use which is non-exclusive, non-time-limited and limited geographically to use at the purchaser's site/location as follows.

The purchaser shall be entitled to use the work to train his/her staff at the purchaser's site/location and shall also be entitled to use parts of the copyright material as the basis for the production of his/her own training documentation for the training of his/her staff at the purchaser's site/location with acknowledgement of source and to make copies for this purpose. In the case of schools/technical colleges, training centers, and universities, the right of use shall also include use by school and college students and trainees at the purchaser's site/location for teaching purposes.

The right of use shall in all cases exclude the right to publish the copyright material or to make this available for use on intranet, Internet, and LMS platforms and databases such as Moodle, which allow access by a wide variety of users, including those outside of the purchaser's site/location.

Entitlement to other rights relating to reproductions, copies, adaptations, translations, microfilming, and transfer to and storage and processing in electronic systems, no matter whether in whole or in part, shall require the prior consent of Festo Didactic.

Information in this document is subject to change without notice and does not represent a commitment on the part of Festo Didactic. The Festo materials described in this document are furnished under a license agreement or a nondisclosure agreement.

Festo Didactic recognizes product names as trademarks or registered trademarks of their respective holders.

All other trademarks are the property of their respective owners. Other trademarks and trade names may be used in this document to refer to either the entity claiming the marks and names or their products. Festo Didactic disclaims any proprietary interest in trademarks and trade names other than its own.

# Table of Contents

Document Preliminaries.....	3
<b>Learning Unit 1 - General Requirements for Operating the Equipment.....</b>	<b>7</b>
<b>Learning Unit 2 - Use for Intended Purpose.....</b>	<b>9</b>
<b>Learning Unit 3 - Guarantee and Liability .....</b>	<b>11</b>
<b>Learning Unit 4 - Work and Safety Instructions .....</b>	<b>13</b>
Safety responsibilities .....	13
General operational safety .....	14
Personal protective equipment (PPE) .....	14
Equipment handling and layout .....	15
Electrical safety.....	16
Mechanical safety with rotating machines .....	17
Cyber security .....	18
<b>Learning Unit 5 - Equipment Installation and Commissioning.....</b>	<b>19</b>
Environmental requirements.....	19
Equipment handling.....	19
Equipment installation in an A4 workstation.....	20
Protective earthing instructions .....	20
Connecting the equipment to ac power outlets.....	21
Three-phase powered equipment .....	22
Single-phase powered equipment .....	22
Setting up rotating machines .....	23
Setting up rotating machines side by side .....	23
Setting up rotating machines in line with each other.....	30
Setting up a rotating machine for stand-alone operation .....	34
Uncoupling rotating machines .....	37
Quick start .....	39
Installing and powering up the equipment.....	39
Powering off, disconnecting, and removing the equipment .....	41
<b>Learning Unit 6 - Equipment Description.....</b>	<b>43</b>
Basic Motor Control Mobile Solution - 120/208 V (8184213) .....	45
Motor provided with the Basic Motor Control Mobile Solution (8184213) .....	49
Basic Motor Control Mobile Solution - 230/400 V (8231927) .....	50
Motor provided with the Basic Motor Control Mobile Solution (8231927) .....	54
3AC Power Supply and Safety Unit (8162950) .....	54
3AC Power Supply and Safety Unit (594826).....	58
3AC Power Supply and Safety Unit (8143155) .....	60
3AC Power Supply and Safety Unit (8143154) .....	64
Electrodynamometer Load (8147352).....	67
Main menu and Settings menu .....	69
Display color .....	70

Main specifications and features .....	71
Squirrel-Cage Induction Machine (8143697) .....	72
Squirrel-Cage Induction Machine (8143698) .....	75
Control and Pilot Devices (8140123) .....	80
Disconnect Switch (8140373) .....	82
Rotary Cam Switch (8140444) .....	84
Starting Resistors (8142976) .....	88
Starting Resistors (8144625) .....	91
Contactor (8140795) .....	93
Control Relay (8140801) .....	95
Motor Starter Protector (8140796) .....	97
Motor Starter Protector (8140797) .....	100
Overload Relay (8140798) .....	103
Overload Relay (8140799) .....	105
Time-Delay Relay (8140800) .....	107
Available functions .....	109
<b>Learning Unit 7 - Fault Insertion for Troubleshooting .....</b>	<b>111</b>
Using fault-insertion switches .....	111
Using fault cards .....	112
<b>Learning Unit 8 - Equipment Maintenance .....</b>	<b>113</b>
General maintenance .....	113
Consumables and replacement parts .....	114
Equipment disposal .....	114
Cleaning .....	114
<b>Learning Unit 9 - Indications of conformity .....</b>	<b>115</b>
Directives and declarations of conformity .....	115
Electromagnetic compatibility (EMC) .....	115

# Document Preliminaries

## About this document

The operator should be familiar with the content of this document before installing and operating the equipment.

The Safety Symbols table at the beginning of this document lists safety symbols that may be present in this document or on the equipment.

This document is freely available for download from the Festo Didactic website.

Upon request, printed copies of this document are freely available. Contact your Festo Didactic sales representative.



**Important.** In this document, "the equipment" and/or "the learning system" specifically refers to the Basic Motor Control Technology Learning System.

This document contains the information required to set up, commission, and carry out maintenance on the equipment. However, for specific instructions or information, refer to the documents listed in the following table. These documents form the core of the documentation for the equipment.











**Table 1: Documents important to the operation of the Basic Motor Control Technology Learning System.**











Document	Part number
Basic Motor Control Technology (workbook)	8145791 (IEC) 8145787 (NEMA)
Basic Motor Control Technology (workbook for instructors)	8145789 (IEC) 8145785 (NEMA)









## Safety Symbols and Procedures

The following table lists the safety and common symbols that may be used in this document and on the equipment. Before performing procedures with the equipment, you should read all sections regarding safety in the User Guide accompanying the equipment. Additional safety procedures are given before any task requiring specific safety precautions.

Symbol	Description
	<b>DANGER</b> indicates a hazard with a high level of risk, which, if not avoided, will result in death or serious injury.
	<b>WARNING</b> indicates a hazard with a medium level of risk, which, if not avoided, could result in death or serious injury.

Symbol	Description
	<p><b>CAUTION</b> indicates a hazard with a low level of risk, which, if not avoided, could result in minor or moderate injury.</p>
	<p><b>NOTICE</b> indicates a hazard with a potentially hazardous situation, which, if not avoided, may result in property damage.</p>
	<p>Caution, risk of danger. Consult the relevant user documentation.</p>
	<p>Caution, risk of electric shock.</p>
	<p>Caution, lifting hazard.</p>
	<p>Caution, hot surface.</p>
	<p>Caution, risk of fire.</p>
	<p>Caution, risk of explosion.</p>
	<p>Caution, belt drive entanglement hazard.</p>
	<p>Caution, chain drive entanglement hazard.</p>

Symbol	Description
	Caution, gear entanglement hazard.
	Caution, hand crushing hazard.
	Static sensitive contents. Observe precautions for handling electrostatic discharge sensitive devices.
	Notice, non-ionizing radiation.
	Consult the relevant user documentation.
	Radio Equipment Directive (RED) geographical restrictions – consult the relevant user documentation.
	Direct current.
	Alternating current.
	Both direct and alternating current.
	Three-phase alternating current.
	Earth (ground) terminal.

Symbol	Description
	Protective conductor terminal.
	Frame or chassis terminal.
	Equipotentiality.
	On (supply).
	Off (supply).
	Equipment protected throughout by double insulation or reinforced insulation.
	In position of a bi-stable push control.
	Out position of a bi-stable push control.

## General Requirements for Operating the Equipment

To safely operate electrical equipment in commercial or training environments, the following requirements apply:

- **Follow national regulations** that govern electrical systems and equipment in commercial or industrial facilities.
- **Ensure supervision.** A qualified supervisor (electrician or trained electrical engineer with documented training) must oversee the laboratory or classroom.
- **Perform correct setup.** Install and commission the equipment strictly according to the accompanying documentation before use.
- **Remove damaged equipment.** Immediately block off and remove damaged or defective devices, cables, leads, pneumatic tubing, or hydraulic hoses from the lab or classroom.
- **Ensure the room is equipped with all required safety devices.** Where local regulations apply, the room must include:
  - DC-sensitive residual current devices (RCDs), type B,  $\leq 30$  mA.
  - Overcurrent protection (circuit breakers or fuses).
  - One or more emergency-off devices to cut power either for the entire room or individual workstations.
  - Security features (e.g., lockable power-on switches or on-off valves) to prevent unauthorized activation of voltage or compressed air.





## Use for Intended Purpose

The equipment may only be used:

- For its intended purpose in teaching and training applications.
- When its safety functions are in flawless condition.

The equipment components are designed with the latest technology and adhere to recognized safety standards. However, improper use can endanger the user and others, and may damage the equipment.

The Festo Didactic learning program is designed solely for training. To keep trainees safe, the training company or supervisors must ensure that all trainees use the equipment as instructed in the Festo Didactic courses and follow the safety guidelines in this document.

	 <b>WARNING</b>
	<p><b>Risk of danger from using the equipment in a way other than prescribed by Festo Didactic!</b></p> <ul style="list-style-type: none"> <li>• Using the equipment in a way other than directed in the accompanying Festo Didactic courses, or using the equipment with equipment from other manufacturers, may increase the risk of injuries or property damage.</li> <li>• To minimize the risk of danger, always respect the specifications marked on the equipment as well as the specifications in the Festo Didactic data sheet of the equipment.</li> <li>• If the equipment includes a third-party component, consult the manufacturer's official documentation for that component—available from the manufacturer or online—to ensure safe use and compliance with all specifications and directives.</li> </ul>



## Guarantee and Liability

Our "general terms and conditions of sale and delivery" are always applicable. These are made available to the operating company no later than on conclusion of the sales contract. Guarantee and liability claims resulting from personal injury and/or property damage are excluded if they can be traced back to one or more of the following causes:

- Use of the equipment for anything other than its intended purpose.
- Improper commissioning and/or operation of the equipment.
- Use of the equipment with defective safety equipment, or with improperly attached or non-functional safety and protective equipment.
- Non-compliance with instructions included in the core documentation about commissioning and operation.
- Unauthorized modifications to the equipment.
- Improperly executed repairs.
- Disasters resulting from the influence of foreign bodies and acts of nature.

Festo Didactic hereby excludes any and all liability for damages suffered by trainees, the training company, and/or any third parties, which occur during use of the equipment in situations which serve any purpose other than training and/or vocational education, unless such damages have been caused by Festo Didactic due to malicious intent or gross negligence.



## Work and Safety Instructions





### Safety responsibilities

Responsibilities are divided by role as shown in the following table.

**Table 2: Responsibilities by role.**

Role	Responsibilities
Operating company	<ul style="list-style-type: none"> <li>● Allow only qualified personnel to work with the equipment.</li> <li>● Ensure personnel are trained in safety regulations and have read the safety information in this document.</li> <li>● Periodically evaluate personnel for safe working practices.</li> </ul>
Instructor	<ul style="list-style-type: none"> <li>● Supervise trainees at all times.</li> <li>● Permit only harmless mistakes and prevent actions that could cause injury or damage.</li> </ul>
Trainees	<ul style="list-style-type: none"> <li>● Read the safety chapter and warnings before use.</li> <li>● Follow all applicable work-safety and accident-prevention rules.</li> <li>● Work only under the supervision of a qualified person.</li> </ul>

## General operational safety

	 <b>CAUTION</b>	
	<p><b>Ignoring basic operational safety rules may lead to accidents, injuries, or equipment damage.</b></p> <ul style="list-style-type: none"> <li>• Trainees must be supervised by an instructor at all times when working with the equipment.</li> <li>• Use the equipment only as instructed in Festo Didactic documentation.</li> <li>• Keep switches, buttons, and disconnectors unobstructed and easy to reach.</li> <li>• Repair or secure faulty equipment immediately.</li> <li>• Wear suitable personal protective equipment (PPE), such as safety glasses and safety shoes.</li> <li>• Avoid wearing loose clothing or accessories that could become entangled in equipment.</li> <li>• Secure long hair to prevent it from interfering with moving parts or obstructing vision.</li> <li>• Keep the work area clean, dry, and free of substances that could cause slips or interfere with equipment operation.</li> </ul>	
	<td data-bbox="593 1220 1385 1294" style="background-color: yellow; text-align: center;">  <b>CAUTION</b> </td>	 <b>CAUTION</b>
<p><b>Improper handling of heavy equipment may cause personal injury or equipment damage.</b></p> <ul style="list-style-type: none"> <li>• Use proper lifting techniques or assistance when moving heavy components marked with the lifting-hazard symbol.</li> </ul>		

## Personal protective equipment (PPE)

Despite built-in safety features, residual risks remain due to misuse or faulty components. To reduce injury risk, always follow these PPE guidelines:

- Wear **safety shoes** when frequently moving equipment between storage and workstations.
- Wear **safety glasses** when working with polarized capacitors, which may explode unexpectedly.
- Wear **hearing protection** when using noisy equipment such as rotating machines.

- Wear **insulating gloves** when handling live electrical components.
- Wear **safety gloves** for mechanical handling (e.g., sharp edges, heavy parts, hot surfaces).

### Equipment handling and layout

#### *NOTICE*

##### **Cable handling**

- Lay out cables without bends, pinches, or contact with hot surfaces (clearly marked if applicable).
- Always unplug by pulling the plug itself—never pull on the cable.
- Prevent continuous tension on cables to avoid damage and disconnection.

#### *NOTICE*

##### **Ventilation and heat management**



- Keep all ventilation slots unobstructed. Place equipment only on hard, flame-resistant surfaces to allow proper airflow.
- Do not install heat-generating equipment near or underneath temperature-sensitive components.

#### *NOTICE*



##### **Workstation setup**

- Check the maximum load capacity of the workstation and ensure it is not exceeded.

## Electrical safety

	 <b>WARNING</b>
	<p><b>Risk of electric shock due to dangerous voltage</b></p> <p>The equipment contains hazardous voltage that can cause death, serious injury, or major property damage if safety instructions are ignored.</p> <p><b>Protective earth (PE)</b></p> <ul style="list-style-type: none"> <li>• Always earth equipment fitted with a PE terminal.</li> <li>• Connect the PE first and disconnect it last.</li> <li>• Do not break or damage yellow-green PE conductors.</li> <li>• Equipment with high leakage current needs a separate PE lead on its extra PE terminal.</li> </ul> <p><b>Prohibited practices</b></p> <ul style="list-style-type: none"> <li>• Never connect power sources in series.</li> <li>• Never connect multiple power supplies to a single ac power wall outlet, as this can cause higher leakage currents.</li> <li>• Do not exceed the input voltage or current rating of any device, as this can lead to heating, shocks, and fires.</li> </ul> <p><b>Safe voltage limits</b></p> <ul style="list-style-type: none"> <li>• Contact with &gt; 30 V ac rms or &gt; 60 V dc can be fatal.</li> <li>• Shield power source outputs and leads from touch; use shrouded safety leads rated CAT II or higher.</li> <li>• Switch off all power sources and de-energize circuits before wiring changes.</li> <li>• Only use detachable mains supply cords, cables, and connection leads with adequate ratings.</li> </ul> <p><b>Capacitors</b></p> <ul style="list-style-type: none"> <li>• Large capacitors may stay charged after power-off. Wait several minutes before opening housings.</li> </ul> <p><b>Low-voltage circuits</b></p> <ul style="list-style-type: none"> <li>• Power low-voltage circuits only with Class II SELV or double-insulated supplies (e.g., Festo Didactic power sources).</li> </ul>

### Mechanical safety with rotating machines

	<b>⚠ WARNING</b>
	<p><b>Risk of serious injury from rotating parts!</b></p> <ul style="list-style-type: none"><li>• Always turn off electric power before mechanically coupling rotating machines.</li><li>• Wait until all moving parts have completely stopped before touching or servicing the equipment.</li><li>• Inspect the protective guard before installation to ensure it is undamaged. Secure the guard by tightening its top screw into the corresponding hole on the prime mover frame using the provided hexagonal key. The rotating machines will not operate without a correctly installed guard. Immediately remove damaged guards from the laboratory or classroom.</li></ul>
	<b>⚠ CAUTION</b>
	<ul style="list-style-type: none"><li>• Rotating machines generate high noise levels, which may cause fatigue or headaches. Always wear appropriate hearing protection, such as protective earpieces, when operating the machines.</li></ul>
<b>NOTICE</b>	
<ul style="list-style-type: none"><li>• Before moving the system, always remove any inertia wheel from the motor shaft to avoid damaging it during transportation.</li></ul>	
<b>NOTICE</b>	
<ul style="list-style-type: none"><li>• Follow all installation and positioning instructions to ensure correct operation of rotating machines.</li></ul>	

## Cyber security

Festo Didactic provides products with security functions that support the safe operation of plants, systems, machines, and networks. However, protecting these assets from cyber threats requires a comprehensive and regularly updated security concept. Festo's products and services form only part of such a strategy.

The customer is responsible for preventing unauthorized access to their equipment and networks. Connections to company networks or the Internet should be made only when necessary and only with appropriate security measures in place—such as firewalls, network segmentation, and defense-in-depth strategies. Without these measures, connecting products to a network can expose vulnerabilities that allow unauthorized remote access, potentially affecting the entire system. This access can be exploited for data theft, manipulation, or sabotage. Common threats include Denial-of-Service attacks, remote code execution, privilege escalation, ransomware, and other malicious activities. In industrial environments, such attacks can lead to unsafe conditions, endangering people and equipment.

Customers should follow Festo's security guidelines and keep their products up to date. Festo continuously enhances its products for improved security and strongly recommends installing updates promptly. Using outdated or unsupported versions increases exposure to cyber threats.

Help Festo maintain safety by reporting security issues to the Festo Product Security Incident Response Team (PSIRT) in German or English via email at [psirt@festo.com](mailto:psirt@festo.com) or through the online form at <https://www.festo.com/psirt>.



### WARNING

#### Unsecure operating conditions due to software tampering

- Software tampering (e.g., viruses, Trojans, malware, worms) can cause unsafe system conditions, potentially leading to serious injury or property damage.
- Keep your software up to date.
- Integrate all automation and actuator components into a comprehensive industrial security concept that reflects current technological standards.
- Ensure all installed products are covered by your security concept.
- Use protective tools, such as antivirus software, to scan files on removable storage media for malware.

## Equipment Installation and Commissioning

### Environmental requirements

The equipment is designed to be installed and stored indoors and operated in the following environmental conditions:

- An altitude up to 2000 m (6560 ft).
- A temperature between 5°C and 40°C (41°F and 104°F).
- A maximum relative humidity of 80% for temperatures up to 31°C (88°F), decreasing linearly to 50% relative humidity at 40°C (104°F).
- Mains supply voltage fluctuations which do not exceed  $\pm 10\%$  of the nominal voltage.
- Transient overvoltages up to the levels of overvoltage category II (1500 V for 120 V mains and 2500 V for 230 V mains).
- Temporary overvoltage occurring on the mains supply.
- A pollution degree of 2 (dry, non-conductive pollution).



The word pollution used above refers to any addition of foreign matter, solid, liquid, or gaseous (ionized gases), that may produce a reduction of dielectric strength or surface resistivity.



### Equipment handling

Before handling equipment, ensure the following:

- You know where to install or relocate the equipment.
- The path is clear—no obstacles, bumps, or slippery surfaces.
- You can safely lift and carry the equipment. Check its weight beforehand if needed.

While carrying equipment, make sure to:

- Maintain a firm grip.
- Hold the equipment close to your waist, with level shoulders. Do not extend your arms.
- Move slowly and maintain stable footing.
- Turn by moving your feet, not by twisting your back.

	 <b>CAUTION</b>
	<p><b>Physical stress likely to occur when handling heavy equipment.</b></p> <ul style="list-style-type: none"><li>• Take extra care when lifting or moving heavy equipment.</li><li>• Equipment heavier than 5 kg (10 lb) are marked with a lifting hazard symbol where not otherwise obvious.</li></ul>

## Equipment installation in an A4 workstation

The equipment is designed either for tabletop use or for installation in an A4 workstation. The following safety guidelines apply when equipment is installed in an A4 workstation.

To install equipment in an A4 workstation, first place the equipment between the lower and upper rails of a workstation row. Then, insert the top edge of the equipment in the upper rail of the workstation row. Finally, insert the bottom edge of the equipment in the lower rails so that the equipment is up straight. Once properly installed, the equipment can slide on the rails.

Always respect the following recommendations when installing equipment in an A4 workstation.

- If the A4 workstation comprises more than one row, equipment that dissipates heat should be installed in the top row. Heat-dissipating equipment are recognized by a hot surface caution sign cut in the top surface of the equipment.
- The manufacturer gives the maximum load limit of the rails of the A4 workstation. It is important to consult the document on the A4 workstation before installing the equipment in order to avoid overloading the rails.



Festo Didactic A4 workstations 8153360 and 8158409 are rated for 50 kg (110 lb) per row.

## Protective earthing instructions

Before you power up the equipment, follow these steps to ensure protective earthing (grounding).

### Power Source module

- Connect the module into a properly grounded ac outlet.
- Its two PE terminals are now at earth potential and serve as the common earthing point.

### Training modules

- Every other module also has two PE terminals.
- Connect them using the supplied PE leads to form strings of up to 20 modules.
- Connect each string to a PE terminal on the Power Source module.



If you use leads other than the ones supplied, they must have a minimum cross-section of 4 mm<sup>2</sup> (EN 60204-1).

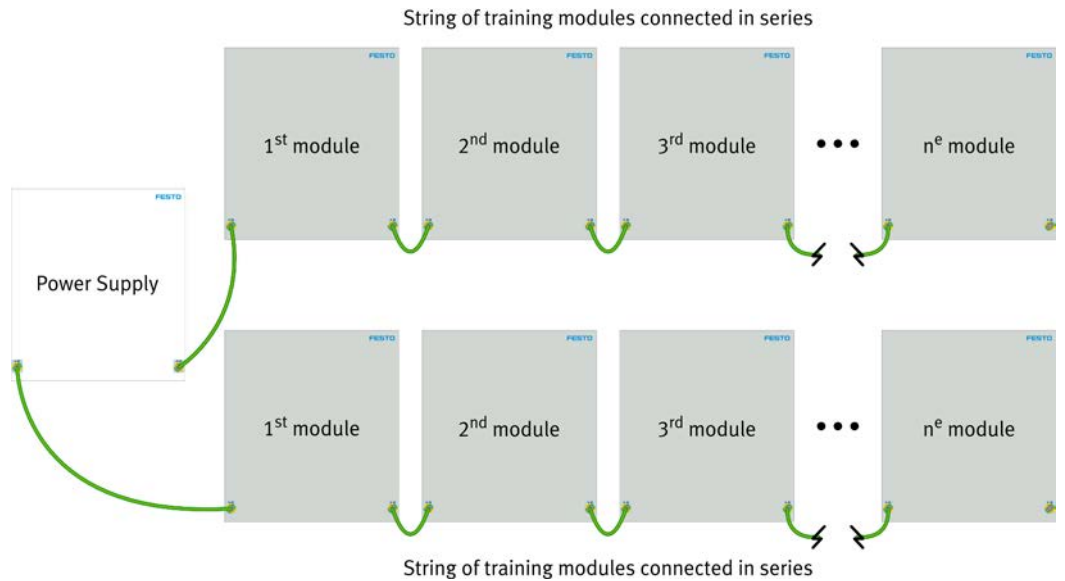

Figure 1: Protective earthing of the training modules in an equipment setup containing a single power supply module.

## Connecting the equipment to ac power outlets

The equipment mostly consists of A4 format modules which are designed for operation in an A4 workstation. When several A4 workstations are installed in the same laboratory classroom, use a different ac power wall outlet to supply power to each A4 workstation.

	<b>CAUTION</b>
	<p>When the earth conductor of an ac power wall outlet is interrupted for any reason, failure to comply with the above requirement may increase the severity of electric shocks resulting from the leakage current of the equipment.</p>

Furthermore, regulation in certain countries requires electric equipment in laboratory classrooms to be connected to ac power outlets that have overcurrent protection (fuses or circuit breakers) and residual current protection (residual current devices of type A or type B). Make sure that the ac power outlets in your laboratory classroom are protected according to the local regulation in your country before using the equipment.

If the ac power outlets in your laboratory classroom do not have the protection features required by the local regulation, use a Festo Didactic power supply that includes a safety unit at each workstation in the classroom.

### Three-phase powered equipment

Connect three-phase powered equipment to one of the available three-phase power supplies, as the following figure shows. Notice that four connection leads (or jumpers) route electric power from the three-phase power supply to any three-phase powered module. Also notice that a fifth protective earthing (PE) lead connects the PE terminal of the three-phase power supply to a PE terminal of the powered module.

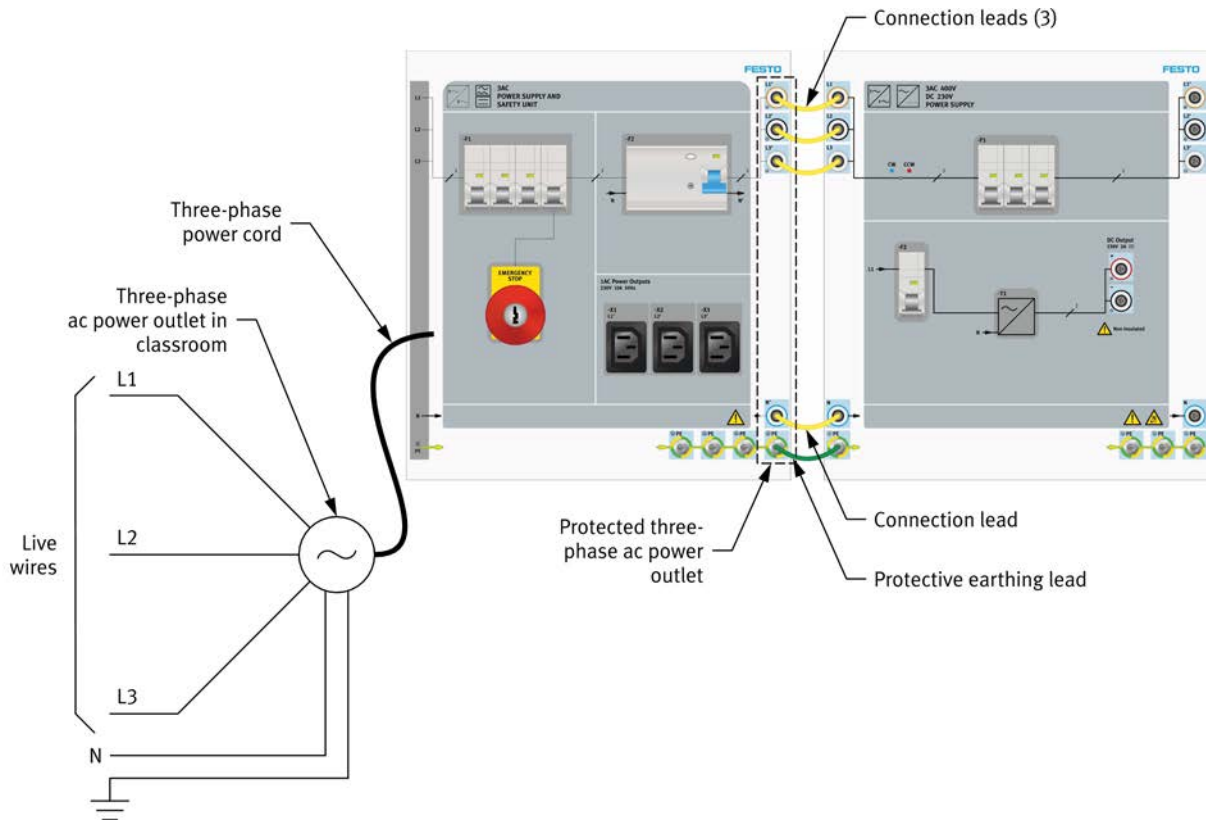

Figure 2: Three-phase powered equipment connected to an ac power outlet via a three-phase power supply.

### Single-phase powered equipment

Connect single-phase powered equipment to one of the available three-phase power supplies, as the following figure shows. Notice that a three-prong, polarized power cord routes electric power from the three-phase power supply to any single-phase powered module. Polarized power cords prevent the inversion of the line and neutral conductors during equipment connection. Also notice that the protective earth (PE) terminals of the three-phase power supply do not need to be connected to the PE terminals of the powered modules. This is because the protective earthing of these modules is achieved via the third prong of their respective power cord.

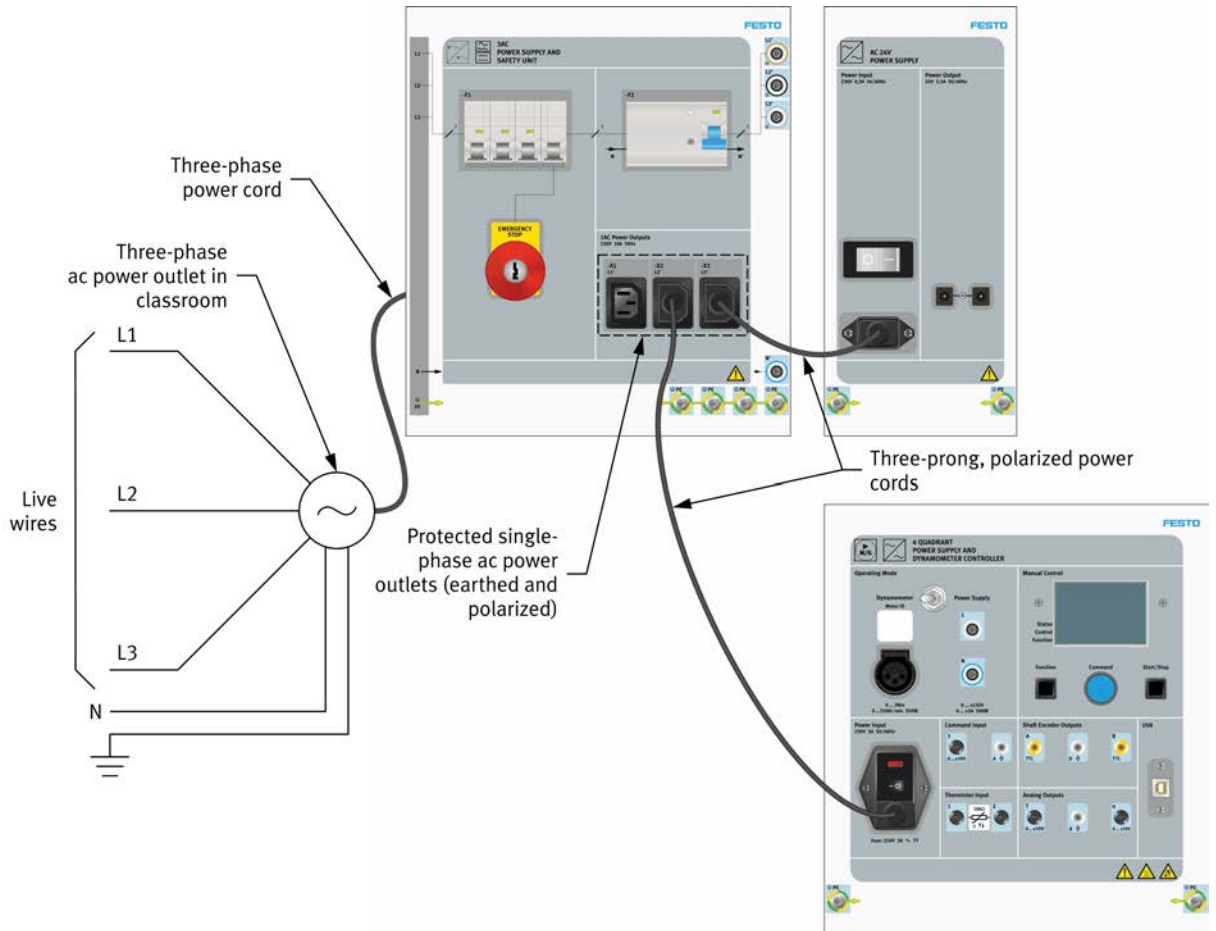

Figure 3: Single-phase powered equipment connected to an ac power outlet via a three-phase power supply.

## Setting up rotating machines

The equipment includes several rotating machines that can be set up in three ways:



1. **Side by side.** Machines are set up next to each other and coupled using a timing belt.
2. **In line.** Machines are aligned and directly coupled. This setup is often used with a four-quadrant prime mover/dynamometer and is used in the Basic Motor Control Technology course.
3. **Stand-alone.** Most machines can also operate independently.

The following subsections explain how to set up each configuration.

### Setting up rotating machines side by side

Some rotating machines are designed for side-by-side setup. Each has a geared pulley on its shaft for mechanical coupling to a prime mover—such as the 4 Quadrant Dynamometer Motor—using a timing belt.

The following procedure explains how to set up a side-by-side configuration, couple the rotating machine to the prime mover using a timing belt, and install the protective guard to prevent contact with moving parts.

	 <b>WARNING</b>
	<p>Always disconnect power before coupling rotating machines. Failure to do so may cause the machines to start unexpectedly, leading to serious hand or arm injury.</p>

1. Place the prime mover on a horizontal surface, making sure that it is close to the A4 workstation housing the rest of the equipment. This facilitates interconnection of the prime mover with the equipment.



If the prime mover was already present near the A4 workstation, make sure it is not connected to any power supply.

Make sure the prime mover is oriented so that its pulley is facing you.

2. Locate the rotating machine required for the lab exercise. Make sure the rotating machine has a geared pulley attached to its shaft.

Place the rotating machine on the work surface so that it is located to the right of the prime mover.





If the rotating machine was already placed to the right of the prime mover, make sure it is not connected to any equipment installed in the A4 workstation.

Make sure the rotating machine is oriented so that its pulley is facing you.

3. Notice that there are two guiding pins mounted on the right-hand side of the base plate of the prime mover. Also notice that there are two guiding slots in the left-hand side of the base plate of the rotating machine.

Slide the rotating machine toward the prime mover so that the guiding pins fully engage with the guiding slots (see the following figure). The two machines are properly installed when their base plates make contact over their full length.

	 <b>CAUTION</b>
	<p>Never attempt to lift two rotating machines together as this may result in injuries and/or equipment damage.</p>

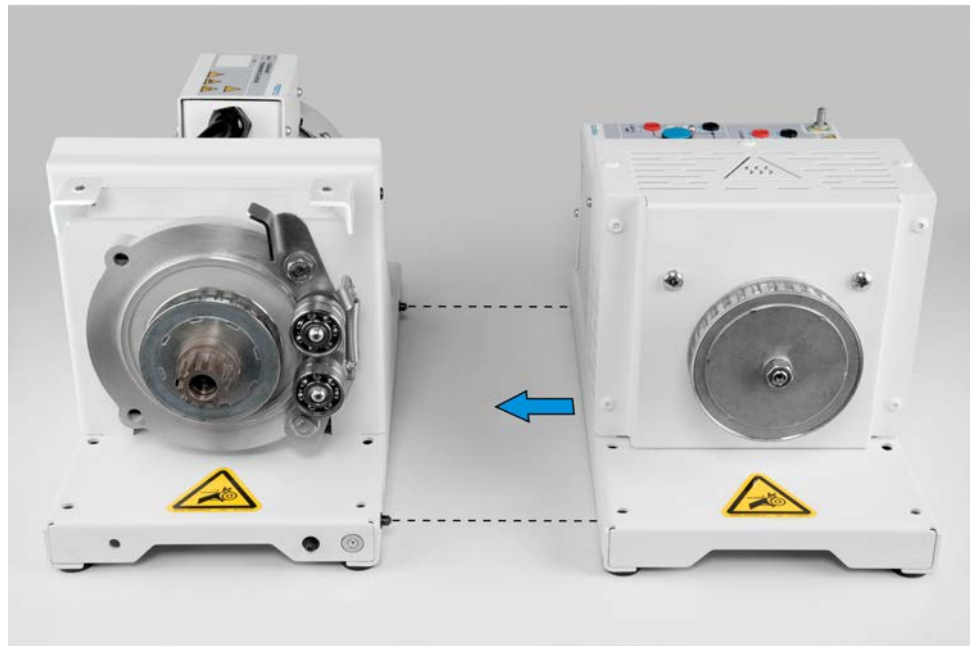

Figure 4: Setting up the prime mover and a rotating machine side by side.

4. Place one end of a timing belt of proper length around the geared pulley of the prime mover (see (a) of the following figure). Then, place the other end of the timing belt around the geared pulley of the rotating machine (see (b) of the following figure).
5. Pull the timing belt toward you (with some twisting action) at the location shown in (c) of the following figure and push down the lower bearing of the belt tensioner on the prime mover with your other hand as shown in (d) of the following figure. Then, push the timing belt toward the machines so that it sits over the lower bearing of the belt tensioner (see (e) of the following figure).
6. Pull the timing belt toward you (with some twisting action) at the location shown in (f) of the following figure and lift the upper bearing of the belt tensioner on the prime mover by pushing the metal lever with a finger of your other hand as shown in (g) of the following figure. Then, push the timing belt toward the machines so that it slips underneath the upper bearing (see (h) of the following figure).

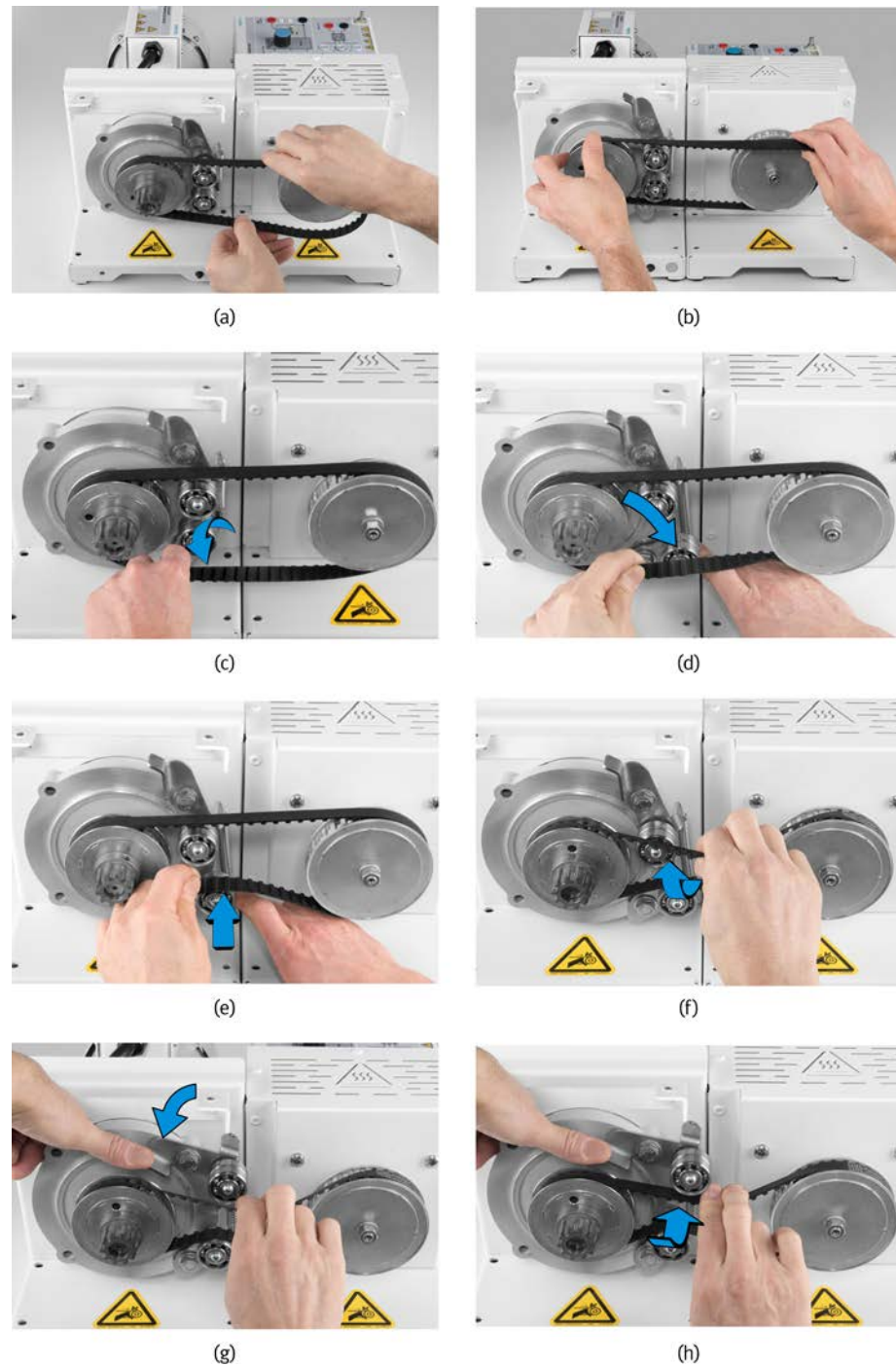

Figure 5: Mechanically coupling a rotating machine to the prime mover using a timing belt.

7. To ensure the timing belt is of proper length and that it installed correctly, rotate the shaft of either the prime mover or the rotating machine by hand. The timing belt is of proper length and installed correctly when both machines rotate and tension is applied to the timing belt by both bearings of the belt tensioner. Also, the timing belt must be in contact with both bearings of the belt tensioner over its full width. See the following figure.



**Figure 6:** To ensure the timing belt is installed correctly, rotate the shaft of either the prime mover or the rotating machine by hand. Both machines should rotate and tension should be applied to the timing belt by both bearings of the tensioner.

8. A limit switch (see the following figure) located in the base plate of each rotating machine (including the prime mover) in the equipment prevents machine operation as long as a protective guard is not installed. This guard is intended to avoid possible injuries resulting from accidental contact with rotating parts of the machine.



Figure 7: A limit switch in the base plate of each rotating machine prevents machine operation as long as a protective guard is not properly installed.

9. Locate the protective guard for side-by-side rotating machines. Notice that there are guiding pins on the bottom side of the protective guard (see the following figure).

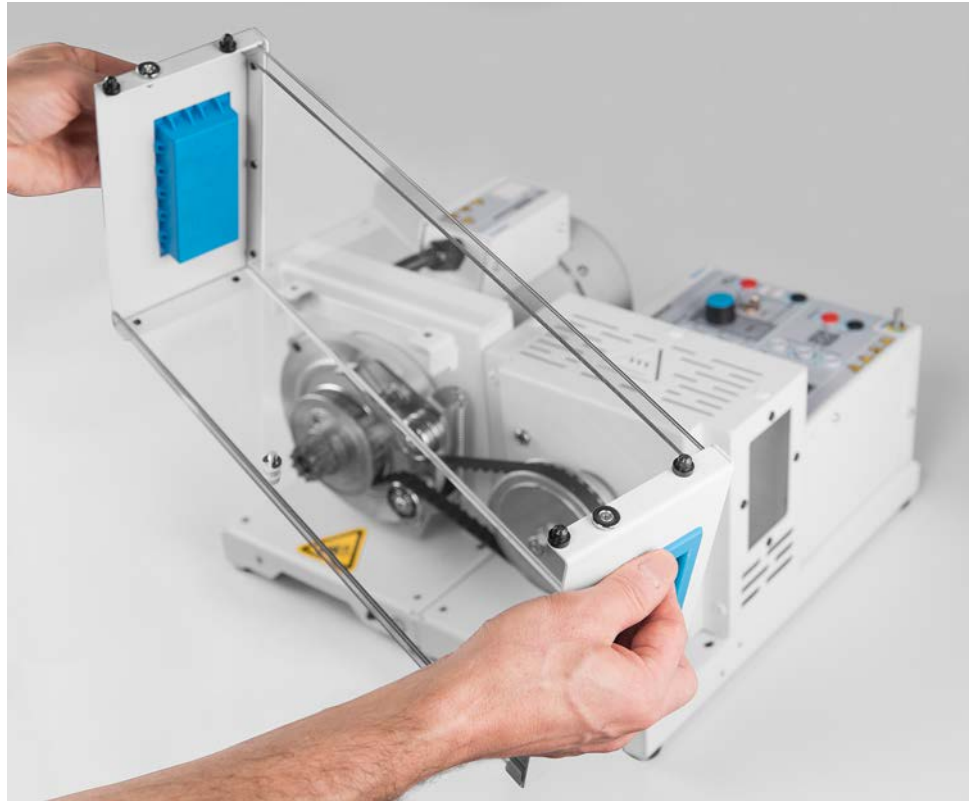



Figure 8: Guiding pins at the bottom of the protective guard for side-by-side rotating machines.

10. To install the protective guard on the prime mover and the rotating machine, align the guiding pins of the protective guard with the holes in the base plates of both machines. Insert the guard into the base plates (see the following figure). All guiding pins must be fully engaged with the holes of the base plates.

Using the provided hexagonal key, screw the top screw on the protective guard in the corresponding hole of the prime mover frame. This secures the guard in place.

Installing the protective guard on the prime mover and the rotating machine actuates the limit switch in the base plate of each machine, thereby allowing both machines to operate.

	 <b>WARNING</b>
	<p>Risk of serious injuries caused by accidental contact with moving parts of rotating machines operated without a protective guard secured in place by the top screw. Never operate rotating machines without a protective guard by inserting objects into the holes of the base plates to actuate the limit switches.</p>

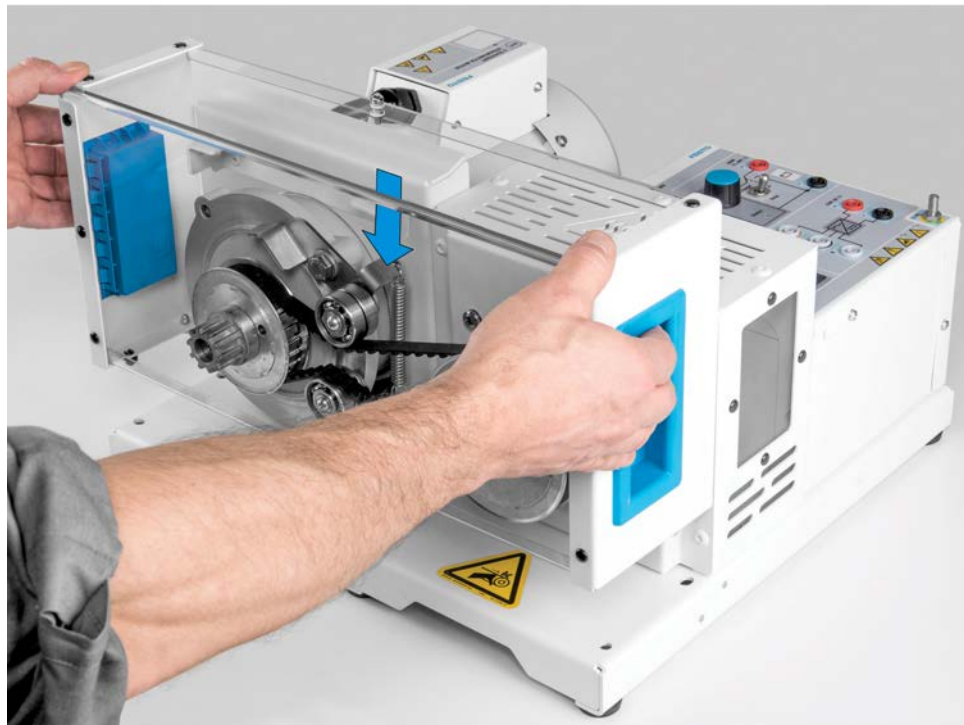



Figure 9: Installing the protective guard on side-by-side rotating machines.

### Setting up rotating machines in line with each other

Several rotating machines are designed to be set up in line with each other. A gear coupling at the end of each machine's shaft enables direct mechanical connection to a prime mover, such as the 4 Quadrant Dynamometer Motor or the Squirrel-Cage Induction Machine.

The following step-by-step procedure explains how to correctly set up a rotating machine in line with a prime mover, mechanically couple them, and install a protective guard to prevent accidental contact with rotating parts.

	 <b>WARNING</b>
	<p>Before coupling rotating machines, always ensure they are disconnected from all electric power sources to prevent accidental startup, which could cause serious hand or arm injuries.</p>

1. Place the prime mover on a horizontal surface. Make sure it is close to the A4 workstation housing the rest of the equipment. This facilitates interconnection between the modules.



If the prime mover was already present near the A4 workstation, make sure it is not connected to any power supply.

Make sure the prime mover is oriented so that its shaft points toward the right-hand side of the work surface.

2. Locate the rotating machine required for the lab exercise. Make sure the rotating machine has a gear attached to the end of its shaft.

Place the rotating machine on the work surface so that it is located to the right of the prime mover.



If the rotating machine was already placed to the right of the prime mover, make sure it is not connected to any equipment installed in the A4 workstation.

Make sure the rotating machine is oriented so that its shaft is facing the prime mover.

3. Notice that there are a guiding pin and a guiding hole on the front side of the base plate of the prime mover. Notice that a guiding pin and a guiding hole are also provided on the front side of the base plate of the rotating machine. Align the rotating machine with the prime mover so that the guiding pins are aligned with the guiding holes (see the following figure).

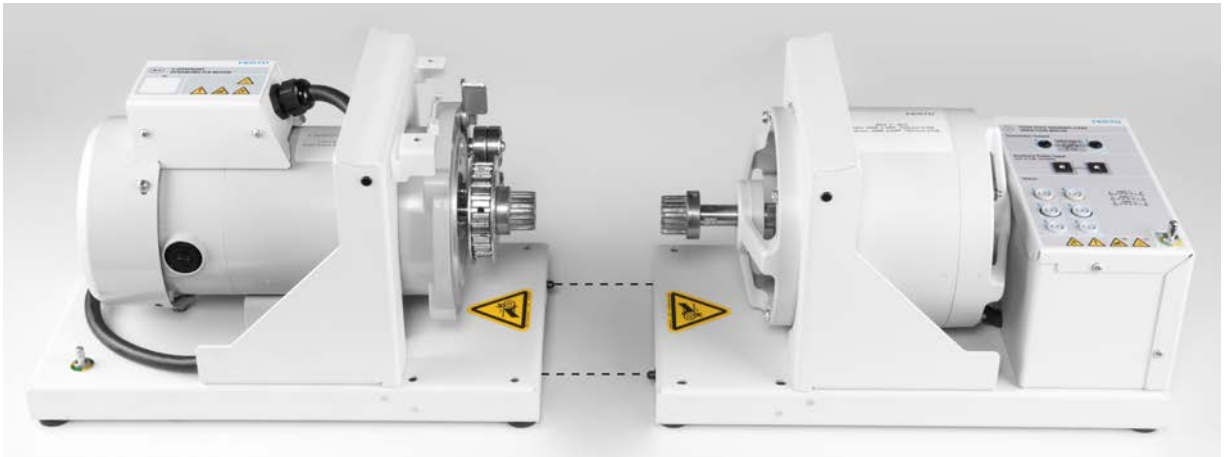

Figure 10: Aligning the rotating machine with the prime mover.

4. Slide the direct coupling supplied with the equipment onto the gear attached to the shaft of the prime mover.

Slide the rotating machine toward the prime mover so that the gear attached to its shaft enters into the direct coupling (the coupling may need to be rotated slightly) and the guiding pins fully engage with the guiding holes (see the following figure). The two machines are properly installed when their base plates make contact over their full width.

	<b>CAUTION</b>
	Never attempt to lift two rotating machines together as this may result in injuries and/or equipment damage.

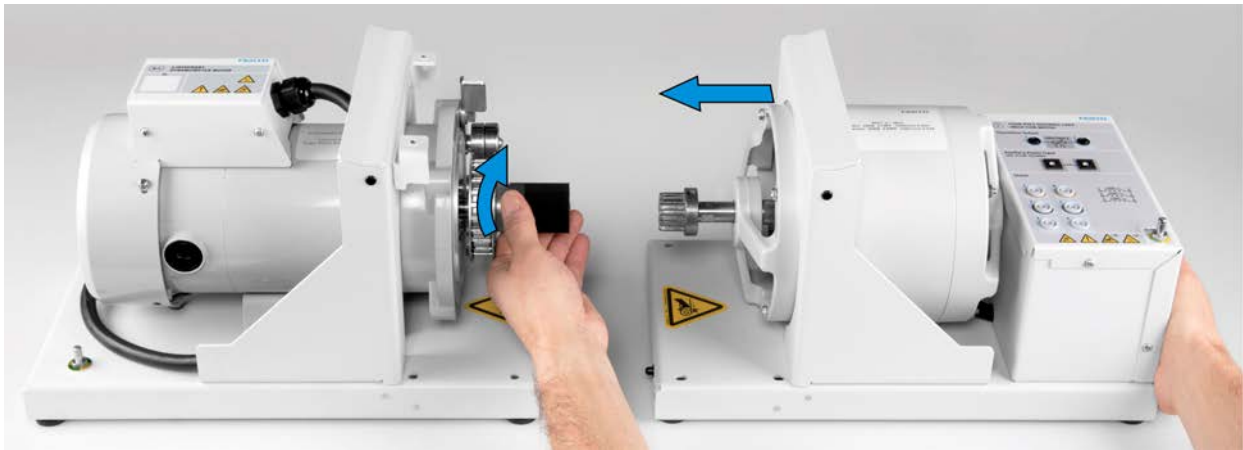

Figure 11: Mechanically coupling a rotating machine to the prime mover using direct coupling.

5. A limit switch (see the following figure) located in the base plate of each rotating machine (including the prime mover) in the equipment prevents machine operation as long as a protective guard is not installed. This guard is intended to avoid possible injuries resulting from accidental contact with rotating parts of the machine.



Figure 12: A limit switch in the base plate of each rotating machine prevents machine operation as long as a protective guard is not properly installed.

6. Locate the protective guard for in-line rotating machines. Notice that there are guiding pins on the bottom side of the protective guard (see the following figure).





Figure 13: Guiding pins at the bottom of the protective guard for in-line rotating machines.

7. To install the protective guard on the prime mover and rotating machine, align its guiding pins with the holes in the base plates of both machines. Insert the guard fully into the base plates (see the following figure). Ensure all guiding pins engage completely with the holes.

Use the provided hexagonal key to screw the top screw of the protective guard into the corresponding hole on the prime mover frame. This secures the guard in place.

When the protective guard is installed, it actuates the limit switch in each machine's base plate, allowing both machines to operate.

 <b>WARNING</b>	
	Serious injuries can occur from accidental contact with moving parts if rotating machines are operated without the protective guard secured by the top screw. Never operate rotating machines without the guard or by inserting objects into the base plate holes to actuate the limit switches.

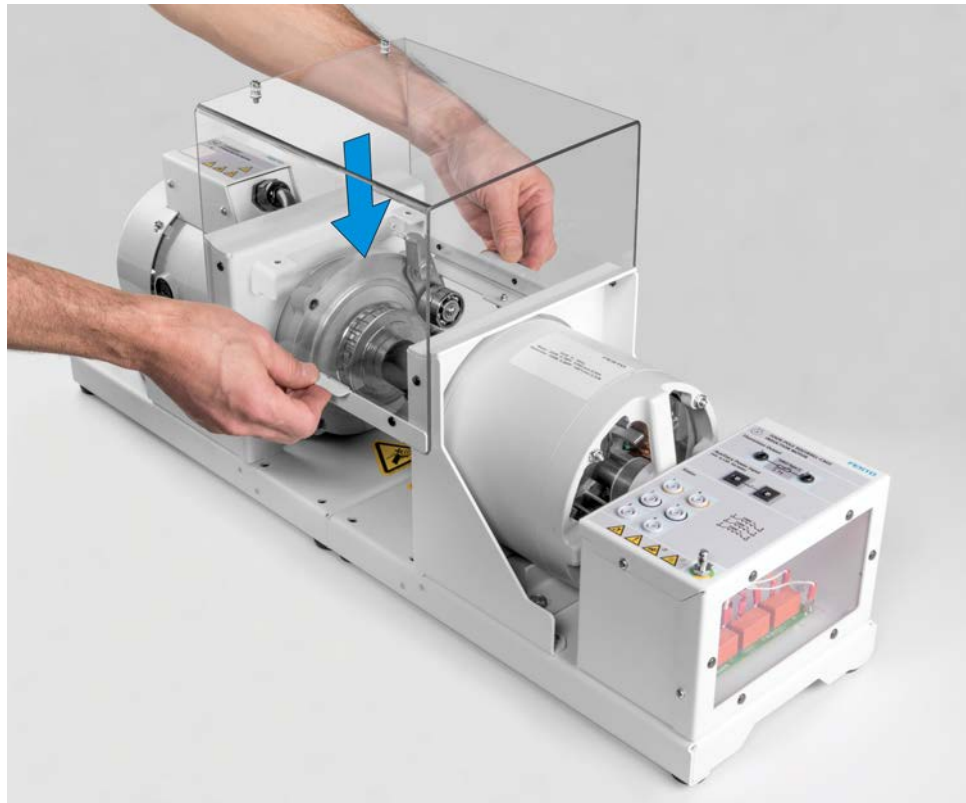

Figure 14: Installing the protective guard on in-line rotating machines.

### Setting up a rotating machine for stand-alone operation

Most rotating machines in the equipment can be set up to operate independently. The following step-by-step procedure explains how to properly configure a rotating machine for stand-alone use. It also shows how to install a protective guard to prevent accidental contact with the machine's rotating parts.

1. Locate the rotating machine required for the lab exercise.
2. Place the rotating machine on a horizontal surface, making sure that it is close to the A4 workstation housing the rest of the equipment. This facilitates interconnection of the rotating machine with the equipment.



If the rotating machine is already placed on a horizontal surface, make sure it is disconnected from the equipment installed in the A4 workstation.

Finally, make sure the rotating machine is oriented so that its pulley is facing you.

3. A limit switch (see the following figure) located in the base plate of each rotating machine (including the 4 Quadrant Dynamometer Motor) in the equipment prevents machine operation as long as a protective guard is not installed. This guard is intended to avoid possible injuries resulting from accidental contact with rotating parts of the machine.



**Figure 15:** A limit switch in the base plate of each rotating machine prevents machine operation as long as a protective guard is not properly installed.

4. Locate the protective guard for stand-alone rotating machines. Notice that there are guiding pins on the bottom side of the protective guard (see the following figure).

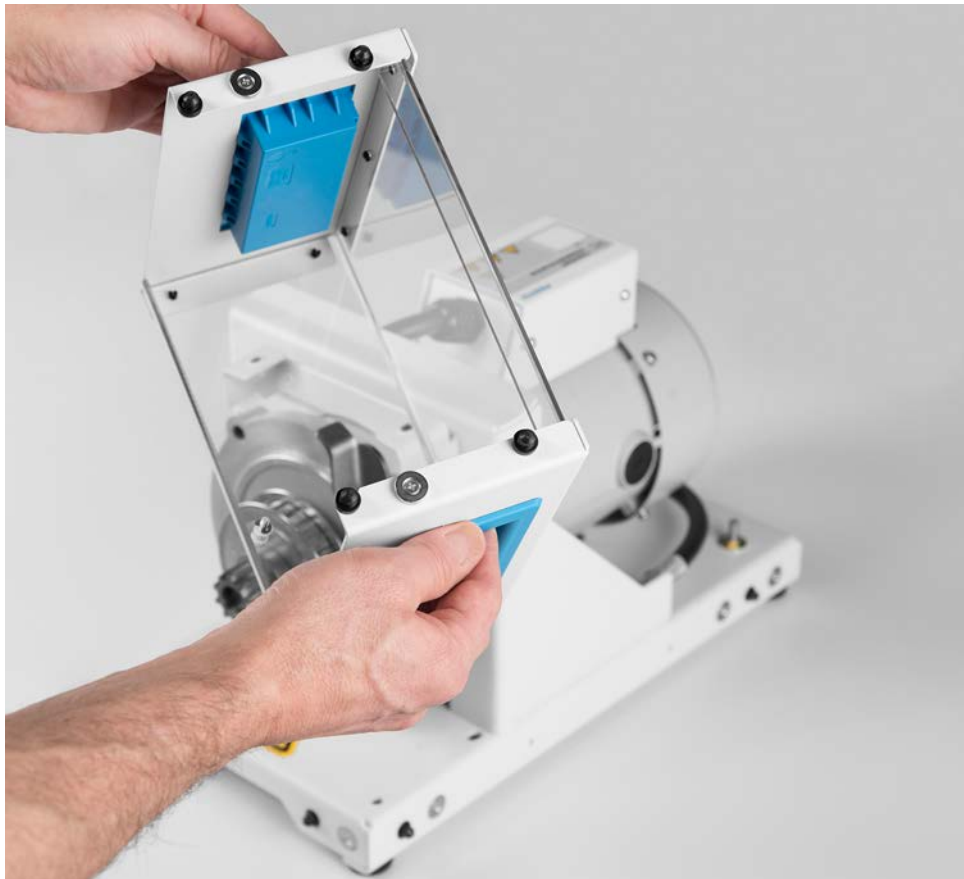



Figure 16: Guiding pins at the bottom of the protective guard for a stand-alone machine.

5. To install the protective guard on the rotating machine, align the guiding pins of the protective guard with the holes in the base plate of the machine then insert the guard into the base plate (see the following figure). The protective guard is properly installed when all guiding pins are fully engaged with the holes of the base plate. Installing the protective guard on the rotating machine actuates the limit switch located in the base plate, thereby allowing the machine to operate.

 <b>WARNING</b>	
	Risk of serious injuries caused by accidental contact with moving parts of a rotating machine operated without a protective guard. Never try to operate a rotating machine without a protective guard by inserting an object into the hole of the base plate to actuate the limit switch.

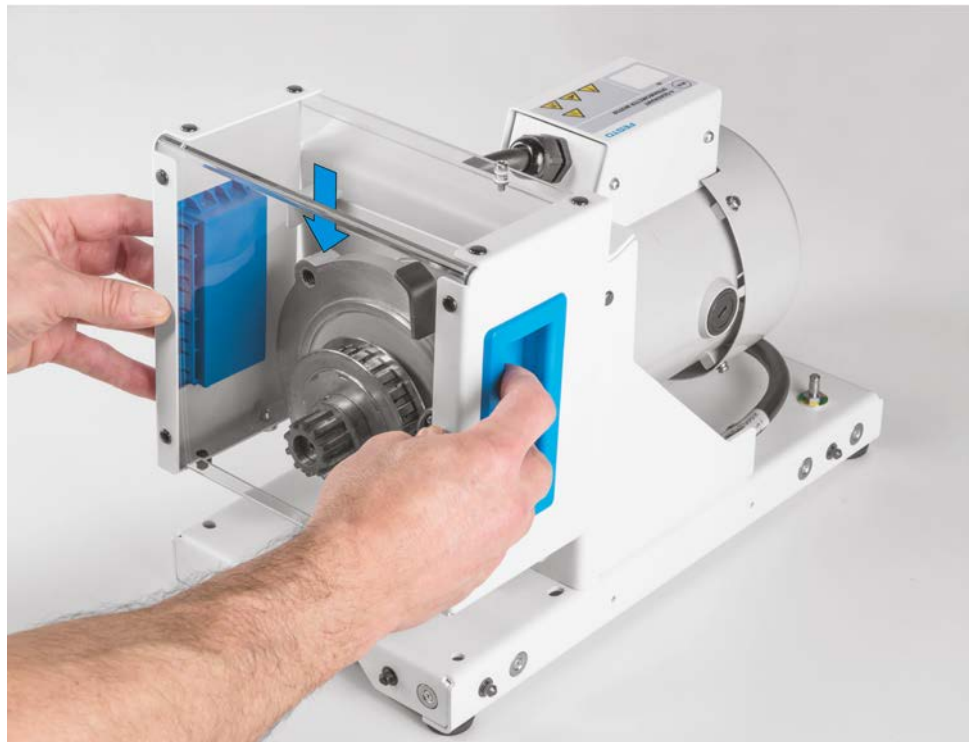



Figure 17: Installing the protective guard on a stand-alone rotating machine.

### Uncoupling rotating machines

The following step-by-step procedure describes how to uncouple rotating machines safely.

	<b>! WARNING</b>
	Before uncoupling rotating machines, make absolutely sure that the machines are disconnected from any source of electric power to prevent the machines from starting inadvertently. This situation, if not avoided, can result in serious hand or arm injury.

1. Turn all electric power sources in the system off.
2. Remove all connections from the rotating machines.
3. Unscrew the top screw of the protective guard using the provided hexagonal key. Remove the protective guard from the rotating machines by pulling it up. Return the protective guard to its storage location.

4. If the rotating machines are coupled using a timing belt, go to the next step. Otherwise, continue the present step.

Slide one of the two rotating machines sideways until the gear attached to the end of its shaft exits the direct coupling (see the following figure). Remove the direct coupling from the shaft of the rotating machine and return it to its storage location.

Go to the last step of the procedure.

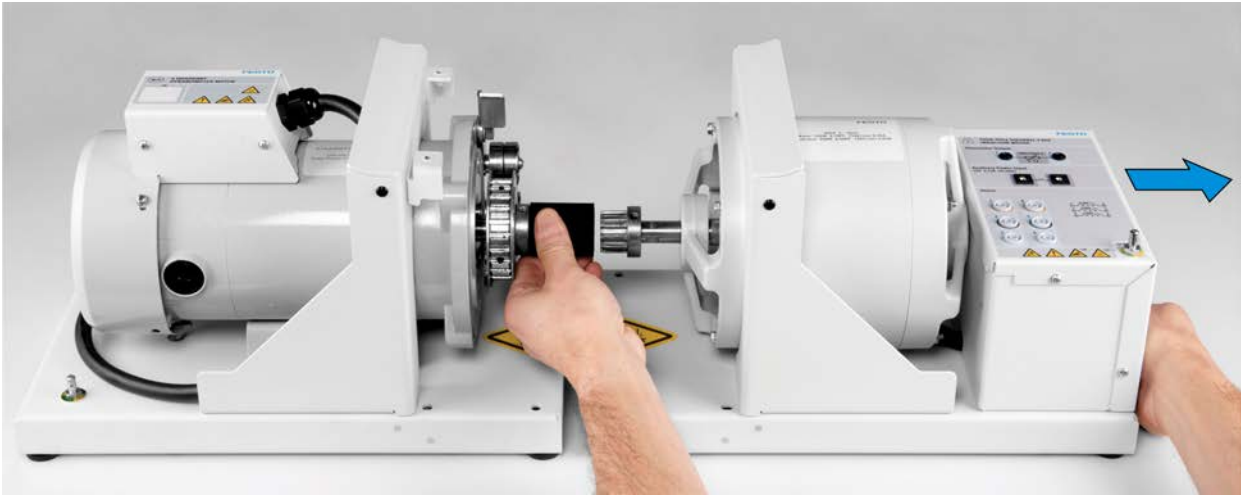

Figure 18: Uncoupling in-line rotating machines.

5. Lift the upper bearing of the belt tensioner on the prime mover by pushing the metal lever with one hand as shown in (a) of the following figure, then use your other hand to pull the timing belt toward you at the location shown in (a) of the figure, until it slips out from the bearings of the belt tensioner. Finally, remove the timing belt from the geared pulley of each rotating machine (see (b) of the following figure) and return it to its storage location.

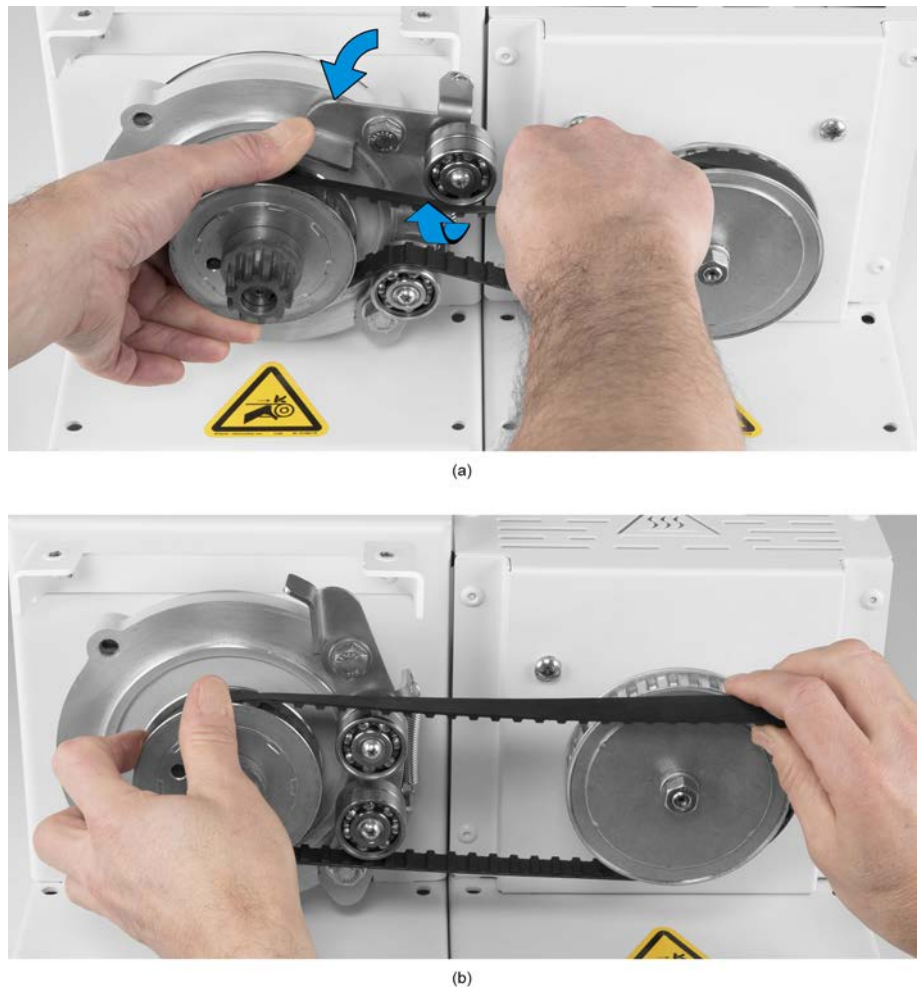

Figure 19: Uncoupling side-by-side rotating machines.

## Quick start

This section provides a quick-start procedure to install and power up the equipment at the beginning of a practice session. This section also provides a general procedure to power off, disconnect, and remove the equipment at the end of a practice session.

### *NOTICE*

The check procedures in the Checking the electrical installation in the laboratory classroom section must have been performed to ensure that the equipment is properly powered by any of the power supply modules. Failure to do so could result in damage to the equipment.

## Installing and powering up the equipment

1. Make sure that you have read and understood the directives in the Safety precautions section of this document before you start using the equipment.

2. Install all the modules required for your practice session in or near the A4 workstation, depending on the module. Refer to the Handling and installing modules section in case of need.



Set up any rotating machine required for your practice session according to the directives in the Setting up rotating machines section.

3. Make the connections required for protective earthing of the equipment according to the directives in the Protective earthing instructions section.

4. Make sure that all power supply modules are turned off.

Connect each power supply module to a properly protected ac power outlet. Refer to the Connecting equipment to ac power outlets section, if necessary.

5. Connect the equipment as required for your practice session. Use the safety connection leads provided with the equipment.

	 <b>WARNING</b>
	Do not use connection leads from other manufacturers. Always use the connection leads provided with the equipment to make all connections. The live parts of these leads have their plugs concealed and insulated in such a way that they cannot be contacted accidentally, allowing safe connection of the equipment without danger of electric shock.



6. Verify your equipment connections.

7. Turn on (i.e., unlock) electric power at your workstation (if applicable).



If necessary, ask the assistance of your supervisor.

8. Turn all power supply modules on. If more than one is present, proceed in order of power rating, starting with the lowest.

	 <b>WARNING</b>
	<p>When the equipment is powered on, keep in mind the following directives to avoid the risk of injuries caused by electric shocks:</p> <ul style="list-style-type: none"><li>• Never leave the equipment unattended.</li><li>• Unless specifically stated otherwise, never modify the equipment connections while power is on.</li><li>• Never move a module while power is on.</li></ul>

### **Powering off, disconnecting, and removing the equipment**

1. Turn all power supply modules off. If more than one is present, proceed in order of power rating, starting with the highest.
2. Turn electric power off at your workstation (if applicable).
3. Remove all equipment connections, finishing with the protective earthing connections. Remove the protective guard then uncouple the rotating machines, if applicable. Return all equipment and connection leads to their storage location.



## Equipment Description

The present unit identifies the front panels and main components (connectors, controls, displays, indicators, etc.) of the equipment. It may also provide safety directives and/or operating instructions specific to certain pieces of equipment, as well as instructions for the part replacement.

The following modules are covered:

- Basic Motor Control Mobile Solution (8145472)
- **Power supplies**
  - Power Supply and Safety Unit (8162950)
  - Power Supply and Safety Unit (594826)
  - Power Supply and Safety Unit (8143155)
  - Power Supply and Safety Unit (8143154)



The differences between each Power Supply and Safety Units are indicated in the following table.

**Table 3: Differences between each Power Supply and Safety Units.**

Power Supply and Safety Units variant	Nominal voltage	Includes an RCD	Includes a dc power output
8162950	230 V	✓	✓
594826	230 V	✓	
8143155	230 V		✓
8143154	120 V		✓

- **Rotating machines and loads**
  - Electrodynamic Load (8147352)
  - Squirrel-Cage Induction Machine (8143697) – 120/208 V variant
  - Squirrel-Cage Induction Machine (8143698) – 230/400 V variant

- **A4 modules**
  - Control and Pilot Devices (8140123)
  - Disconnect Switch (8140373)
  - Rotary Cam Switch (8140444)
  - Starting Resistors (8142976) – 25  $\Omega$  variant
  - Starting Resistors (8144625) – 100  $\Omega$  variant
  
- **Faultable interconnection boxes**
  - Contactor (8140795)
  - Control Relay (8140801)
  - Motor Starter Protector (8140796)
  - Motor Starter Protector (8140797)
  - Overload Relay (8140798)
  - Overload Relay (8140799)
  - Time-Delay Relay (8140800)

## Basic Motor Control Mobile Solution - 120/208 V (8184213)

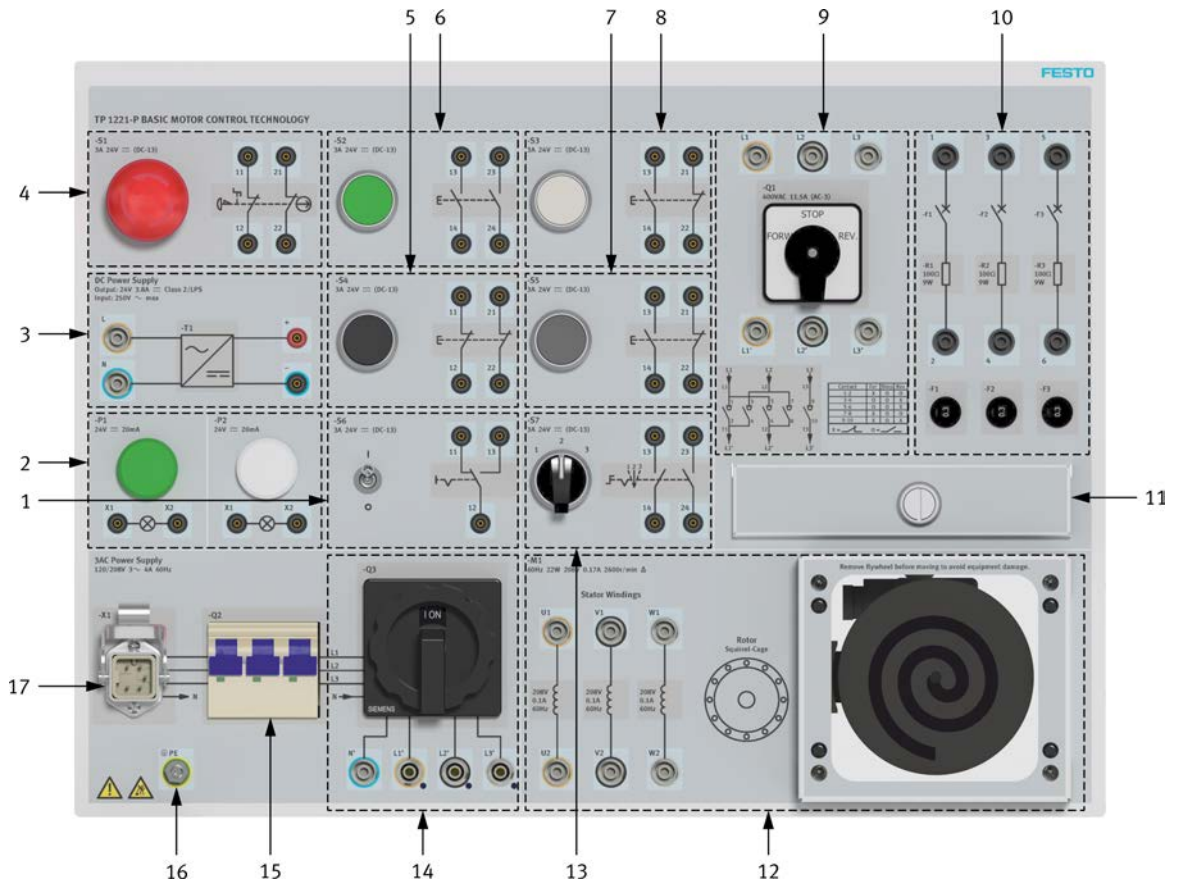



Figure 20: Basic Motor Control Mobile Solution.

Table 4: Components of the Basic Motor Control Mobile Solution (8184213).

Number	Name	Description
1	Single-pole, double-throw toggle switch (-S6)	Three terminals provide access to a single-pole, double-throw toggle switch.
2	Indicator lights (-P1, -P2)	Two pairs of terminals provide access to two indicator lights.

Number	Name	Description
3	DC power output (-T1)	<p>A pair of positive and negative 2 mm terminals supply 24 V dc power through a rectifier.</p> <p>In order for ac power to be supplied to the rectifier, electrical jumpers must be added between L1 and L, as well as between N and N. Removing these jumpers cuts off the supply of 24 V dc power.</p>
4	Mushroom-head push button (-S1)	<p>Two pairs of terminals provide access to a mushroom-head push button that acts similarly to an emergency button (double-pole, single-throw normally closed switch). Pressing the button immediately opens the circuit between each pair of terminals. To reset the push-button, rotate it until it releases.</p>
5	Normally closed push button (-S4)	<p>Two pairs of terminals provide access to a double-pole, single-throw switch. The contacts between both pairs of terminals are normally closed. The switch is actuated by a push button.</p>
6	Normally open push button (-S2)	<p>Two pairs of terminals provide access to a double-pole, single-throw switch. The contacts between both pairs of terminals are normally open. The switch is actuated by a push button.</p>
7	Mixed normally open and close push button (-S5)	<p>Two pairs of terminals provide access to a double-pole, single-throw switch. The contacts between one pair of terminals are normally open, while the contacts between the other pair are normally closed. The switch is actuated by a push button.</p>
8	Mixed normally open and close push button (-S3)	<p>Two pairs of terminals provide access to a double-pole, single-throw switch. The contacts between one pair of terminals are normally open, while the contacts between the other pair are normally closed. The switch is actuated by a push button.</p>
9	Rotary cam switch (-Q1)	<p>Six terminals provide access to a rotary cam switch. Follow the instructions in the diagram below the switch for connection information.</p>
10	Resistors and circuit-breakers (-R1, -R2, -R3, and -F1, -F2, -F3)	<p>Three pairs of terminals provide access to three resistors and three circuit breakers. The circuit breakers can be reset using the push buttons below the connectors.</p>
11	Fault-insertion switches	<p>Fault-insertion switches allow the insertion of faults for troubleshooting purposes. A lockable cover prevents students from accessing the switches.</p>

Number	Name	Description
12	Squirrel-cage induction motor machine (-M1)	Three pairs of terminals provide access to each line of the motor stator windings. See the following subsection for more information on the motor provided with the Basic Motor Control Mobile Solution.
13	Double-pole, triple-throw selector switch (-S7)	Two pairs of terminals provide access to a double-pole, triple-throw selector switch. The contacts between one pair of terminals are normally open, while the contacts between the other pair are normally closed. The switch is actuated by a rotary selector switch.
14	Main power switch and three-phase power supply (-Q3)	Four line terminals provide three-phase ac power. The main power switch turns on or off the power to the line terminals.
15	Three-phase circuit breaker (-Q2)	Levers for the three-phase circuit breaker protecting the three-phase power supply. The three-phase circuit breaker can be reset using the three levers.
16	Ground connector	Terminal that provides grounding to the module and any connected module.
17	AC power input (-X1)	Main power input for the Motor Control Mobile Solution. This power input must be connected to a three-phase ac power supply.

	 <b>WARNING</b>
	<p>Always connect a ground terminal of each module in your setup to a ground terminal of a Power Supply and Safety Unit.</p>

**Table 5: Main specifications of the Basic Motor Control Mobile Solution (8184213).**

Components and parameters	Main specifications
Input power	<ul style="list-style-type: none"> <li>● Maximum current: 4 A</li> <li>● AC power network voltage and frequency: 120/208 V – 60 Hz</li> <li>● Electrical installation: 3 phases, star (wye) configuration including neutral and earth wires, protected by a 20 A circuit breaker.</li> <li>● Connection via power cord with NEMA L21-20 plug (included).</li> </ul>
Power supplies output (integrated in suitcase)	<ul style="list-style-type: none"> <li>● 120/208 V, 4 A, 60 Hz</li> <li>● 24 V DC, 3.8 A</li> </ul>
DC power supply input	250 V ac max.
Control devices	24 V DC, 3 A (per contact)
Pilot lights	24 V DC, 20 mA
Cam switch	Forward-stop-reverse, 3AC 400 V, 11.5 A
Power resistors (3)	100 $\Omega$ , 9 W, protected with electronic fuses
Induction motor	Three-phase, 208 V, 22 W, 0.17 A, 60 Hz, 2600 r/min, delta
Faults for troubleshooting exercises	7 faults switches located on the suitcase faceplate and 4 faults keys for the switchgear components (contactors, relays, etc.)
Connectors	Connections are made via 4 mm safety sockets for power and 2 mm safety sockets for control.
Ingress protection rating	IP20
Electromagnetic compatibility	Group 1, Class A (industrial environment, EN 55011)
Dimensions (H x W x D)	625 x 475 x 290 mm (24.6 x 18.7 x 11.4 in)
Weight	23.5 kg (51.8 lb)

### **Motor provided with the Basic Motor Control Mobile Solution (8184213)**

The motor provided with the portable edition of the Basic Motor Control Technology system is a two-pole, three-phase squirrel-cage induction machine. It is configured as a six-lead motor and is designed to be connected as a triangle (delta) configuration.

The motor has a permanent flywheel to increase its inertia. More inertia means longer acceleration and deceleration times. This helps to replicate real-life conditions where a motor would be tied to an actual mechanical load.

A plastic brake can be used to stop the motor once it is disconnected instead of waiting for it to stop by itself.

#### ***NOTICE***

Do not use this brake when the motor is powered as it will wear down the brake and can eventually overheat the motor.

In order to meet safety regulations, the motor is already grounded.



#### **Setting up the portable edition.**

<https://lx.festo.com/media/6499944932f54c4b8aeacd131faea1d6>



#### **Braking the motor on the portable edition.**

<https://lx.festo.com/media/72d781e08e15449fa882dcaa03aaf9b3>

## Basic Motor Control Mobile Solution - 230/400 V (8231927)

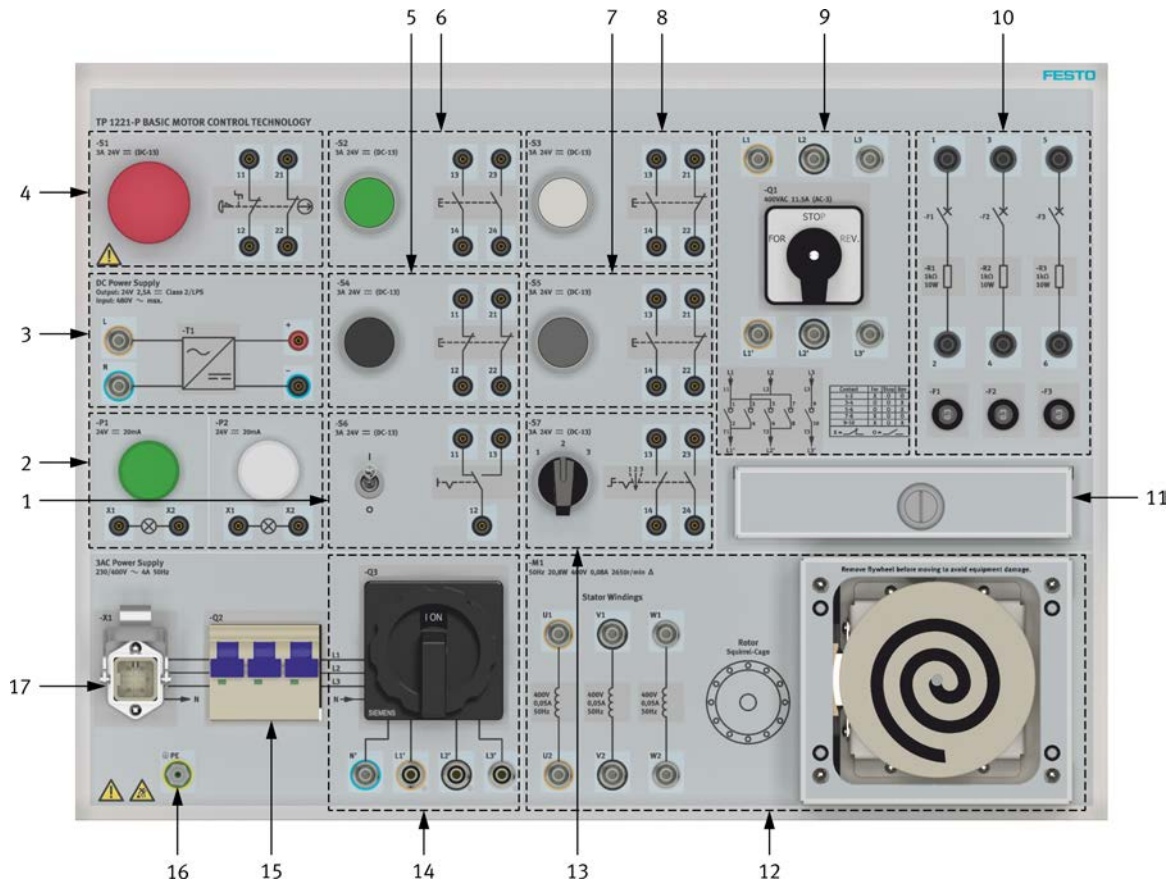



Figure 21: Basic Motor Control Mobile Solution (8231927).



Table 6: Components of the Basic Motor Control Mobile Solution (8231927).

Number	Name	Description
1	Single-pole, double-throw toggle switch (-S6)	Three terminals provide access to a single-pole, double-throw toggle switch.
2	Indicator lights (-P1, -P2)	Two pairs of terminals provide access to two indicator lights.

Number	Name	Description
3	DC power output (-T1)	<p>A pair of positive and negative 2 mm terminals supply 24 V dc power through a rectifier.</p> <p>In order for ac power to be supplied to the rectifier, electrical jumpers must be added between L1 and L, as well as between N and N. Removing these jumpers cuts off the supply of 24 V dc power.</p>
4	Mushroom-head push button (-S1)	<p>Two pairs of terminals provide access to a mushroom-head push button that acts similarly to an emergency button (double-pole, single-throw normally closed switch). Pressing the button immediately opens the circuit between each pair of terminals. To reset the push-button, rotate it until it releases.</p>
5	Normally closed push button (-S4)	<p>Two pairs of terminals provide access to a double-pole, single-throw switch. The contacts between both pairs of terminals are normally closed. The switch is actuated by a push button.</p>
6	Normally open push button (-S2)	<p>Two pairs of terminals provide access to a double-pole, single-throw switch. The contacts between both pairs of terminals are normally open. The switch is actuated by a push button.</p>
7	Mixed normally open and close push button (-S5)	<p>Two pairs of terminals provide access to a double-pole, single-throw switch. The contacts between one pair of terminals are normally open, while the contacts between the other pair are normally closed. The switch is actuated by a push button.</p>
8	Mixed normally open and close push button (-S3)	<p>Two pairs of terminals provide access to a double-pole, single-throw switch. The contacts between one pair of terminals are normally open, while the contacts between the other pair are normally closed. The switch is actuated by a push button.</p>
9	Rotary cam switch (-Q1)	<p>Six terminals provide access to a rotary cam switch. Follow the instructions in the diagram below the switch for connection information.</p>
10	Resistors and circuit-breakers (-R1, -R2, -R3, and -F1, -F2, -F3)	<p>Three pairs of terminals provide access to three resistors and three circuit breakers. The circuit breakers can be reset using the push buttons below the connectors.</p>
11	Fault-insertion switches	<p>Fault-insertion switches allow the insertion of faults for troubleshooting purposes. A lockable cover prevents students from accessing the switches.</p>

Number	Name	Description
12	Squirrel-cage induction motor machine (-M1)	Three pairs of terminals provide access to each line of the motor stator windings. See the following subsection for more information on the motor provided with the Basic Motor Control Mobile Solution.
13	Double-pole, triple-throw selector switch (-S7)	Two pairs of terminals provide access to a double-pole, triple-throw selector switch. The contacts between one pair of terminals are normally open, while the contacts between the other pair are normally closed. The switch is actuated by a rotary selector switch.
14	Main power switch and three-phase power supply (-Q3)	Four line terminals provide three-phase ac power. The main power switch turns on or off the power to the line terminals.
15	Three-phase circuit breaker (-Q2)	Levers for the three-phase circuit breaker protecting the three-phase power supply. The three-phase circuit breaker can be reset using the three levers.
16	Ground connector	Terminal that provides grounding to the module and any connected module.
17	AC power input (-X1)	Main power input for the Motor Control Mobile Solution. This power input must be connected to a three-phase ac power supply.

	 <b>WARNING</b>
	<p>Always connect a ground terminal of each module in your setup to a ground terminal of a Power Supply and Safety Unit.</p>

	 <b>WARNING</b>
	<p>The mushroom-head push button does not serve a safety function and is used in the training system for educational purposes only.</p>

**Table 7: Main specifications of the Basic Motor Control Mobile Solution (8231927).**

Components and parameters	Main specifications
Input power	<ul style="list-style-type: none"> <li>● Maximum current: 4 A</li> <li>● AC power network voltage and frequency: 230/400 V – 50 Hz</li> <li>● Electrical installation: 3 phases, star (wye) configuration including neutral and earth wires, protected by a 20 A circuit breaker.</li> <li>● Connection via power cord with IEC 60309 plug (included).</li> </ul>
Power supplies output (integrated in suitcase)	<ul style="list-style-type: none"> <li>● 230/400 V, 4 A, 50 Hz</li> <li>● 24 V DC, 2.5 A</li> </ul>
DC power supply input	480 V ac max.
Control devices	24 V DC, 3 A (per contact)
Pilot lights	24 V DC, 20 mA
Cam switch	Forward-stop-reverse, 3AC 400 V, 11.5 A
Power resistors (3)	1 k $\Omega$ , 10 W, protected with electronic fuses
Induction motor	Three-phase, 400 V, 20.8 W, 0.08 A, 50 Hz, 2650 r/min, delta
Faults for troubleshooting exercises	7 faults switches located on the suitcase faceplate and 4 faults keys for the switchgear components (contactors, relays, etc.)
Connectors	Connections are made via 4 mm safety sockets for power and 2 mm safety sockets for control.
Ingress protection rating	IP20
Electromagnetic compatibility	Group 1, Class A (industrial environment, EN 55011)
Dimensions (H x W x D)	625 x 475 x 290 mm (24.6 x 18.7 x 11.4 in)
Weight	23.5 kg (51.8 lb)

Components and parameters	Main specifications
CE and UKCA markings	<ul style="list-style-type: none"> <li>● Low-Voltage Directive</li> <li>● EMC Directive</li> <li>● RoHS Directive</li> </ul>

### Motor provided with the Basic Motor Control Mobile Solution (8231927)

The motor provided with the portable edition of the Basic Motor Control Technology system is a two-pole, three-phase squirrel-cage induction machine. It is configured as a six-lead motor and is designed to be connected as a triangle (delta) configuration.

The motor has a permanent flywheel to increase its inertia. More inertia means longer acceleration and deceleration times. This helps to replicate real-life conditions where a motor would be tied to an actual mechanical load.

A plastic brake can be used to stop the motor once it is disconnected instead of waiting for it to stop by itself.

<i>NOTICE</i>
Do not use this brake when the motor is powered as it will wear down the brake and can eventually overheat the motor.

In order to meet safety regulations, the motor is already grounded.

	<p><b>Setting up the portable edition.</b></p> <p><a href="https://lx.festo.com/media/6499944932f54c4b8aeacd131faea1d6">https://lx.festo.com/media/6499944932f54c4b8aeacd131faea1d6</a></p>
---	---

	<p><b>Braking the motor on the portable edition.</b></p> <p><a href="https://lx.festo.com/media/72d781e08e15449fa882dcaa03aaf9b3">https://lx.festo.com/media/72d781e08e15449fa882dcaa03aaf9b3</a></p>
---	---

### 3AC Power Supply and Safety Unit (8162950)

The 3AC Power Supply and Safety Unit provides power to circuits. It can operate as any of the following:

- Three-phase ac power source
- Single-phase ac power source
- 24 V dc power source

The 3AC Power Supply and Safety Unit provides power to and removes power from the circuits in the practical exercises. It must be connected to a three-phase power outlet. The module is equipped with a main circuit breaker and an emergency switch push button.

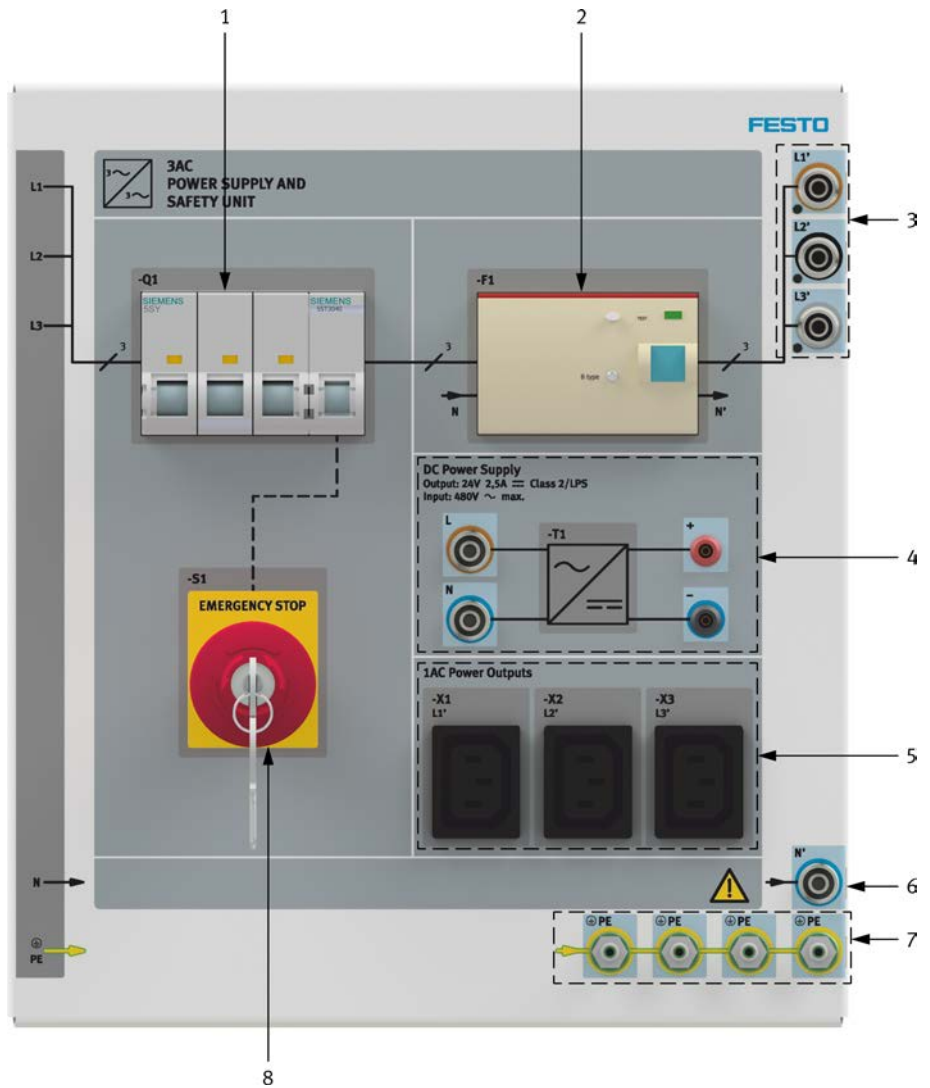





Figure 22: 3AC Power Supply and Safety Unit (8162950).

Table 8: Components of the 3AC Power Supply and Safety Unit (8162950).

Number	Component	Description
1	Three-pole circuit breaker with undervoltage release	Protection against short circuits.

Number	Component	Description
2	Residual current circuit breaker	Protection that disconnects the circuit in case of current leakage.
3	Three-phase ac power output	Output terminals for each of the three lines (L1', L2', L3'). Near each terminal is an LED that lights up when that terminal is powered.
4	24 V dc power output	A pair of positive and negative 2 mm terminals supply 24 V dc power through a rectifier.  In order for ac power to be supplied to the rectifier, electrical jumpers must be added between L1 and L, as well as between N and N. Removing these jumpers cuts off the supply of 24 V dc power.
5	Single-phase ac power outlets	Standard power outlets.
6	Neutral output	Output terminal for the neutral line.
7	Protective earthing terminals	Terminals that provide protective earthing to the module and any connected module.
8	Lockable power-on switch and emergency stop button	Protection that removes power from the circuit when depressed. A key is required to reset the push button.

	 <b>WARNING</b>
	<p>Always connect a ground terminal of each module in your setup to a ground terminal of a 3AC Power Supply and Safety Unit.</p>

	 <b>CAUTION</b>
	<p>Do not leave the key in the power-on switch after locking or unlocking it. If you need to rapidly press on the emergency stop button, the presence of a key in the switch could cause a hand injury.</p>

**Table 9: Main specifications of the 3AC Power Supply and Safety Unit (8162950).**

Components and parameters	Main specifications
Input power	<ul style="list-style-type: none"> <li>● Maximum current: 10 A</li> <li>● AC power network voltage and frequency: 230/400 V – 50 Hz</li> <li>● Electrical installation: 3 phases, star (wye) configuration including neutral and earth wires, protected by a 20 A circuit breaker.</li> <li>● Connection via CEE-plug 16 A.</li> </ul>
Output power	<ul style="list-style-type: none"> <li>● 3 AC 400 V, 50 Hz, 10 A (max)</li> <li>● 24 V DC, 2.5 A</li> </ul>
DC power supply input	480 V ac max.
Protections	Short circuit and overload
RCD protection	Type B, 30 mA
Outputs	<ul style="list-style-type: none"> <li>● Three-phase output via 4 mm safety sockets with pilot lights indicating voltage presence</li> <li>● 24 V DC output via 2 mm safety sockets</li> <li>● Three single-phase IEC C13 outlets</li> </ul>
Mounting	Designed for DIN A4 mounting frames
Ingress protection rating	IP20
Electromagnetic compatibility	Group 1, Class A (industrial environment, EN 55011)
Dimensions (H x W x D)	297 x 266 x 140 mm (11.69 x 10.47 x 5.51 in)
Weight	4.6 kg (10.14 lb)
CE and UKCA markings	<ul style="list-style-type: none"> <li>● Low-Voltage Directive</li> <li>● EMC Directive</li> <li>● RoHS Directive</li> </ul>

## 3AC Power Supply and Safety Unit (594826)

The 3AC Power Supply and Safety Unit provides power to circuits. It can operate as any of the following:

- Three-phase ac power source
- Single-phase ac power source

The 3AC Power Supply and Safety Unit provides power to and removes power from the circuits in the practical exercises. It must be connected to a three-phase power outlet. The module is equipped with two types of circuit breakers and an emergency switch push button.

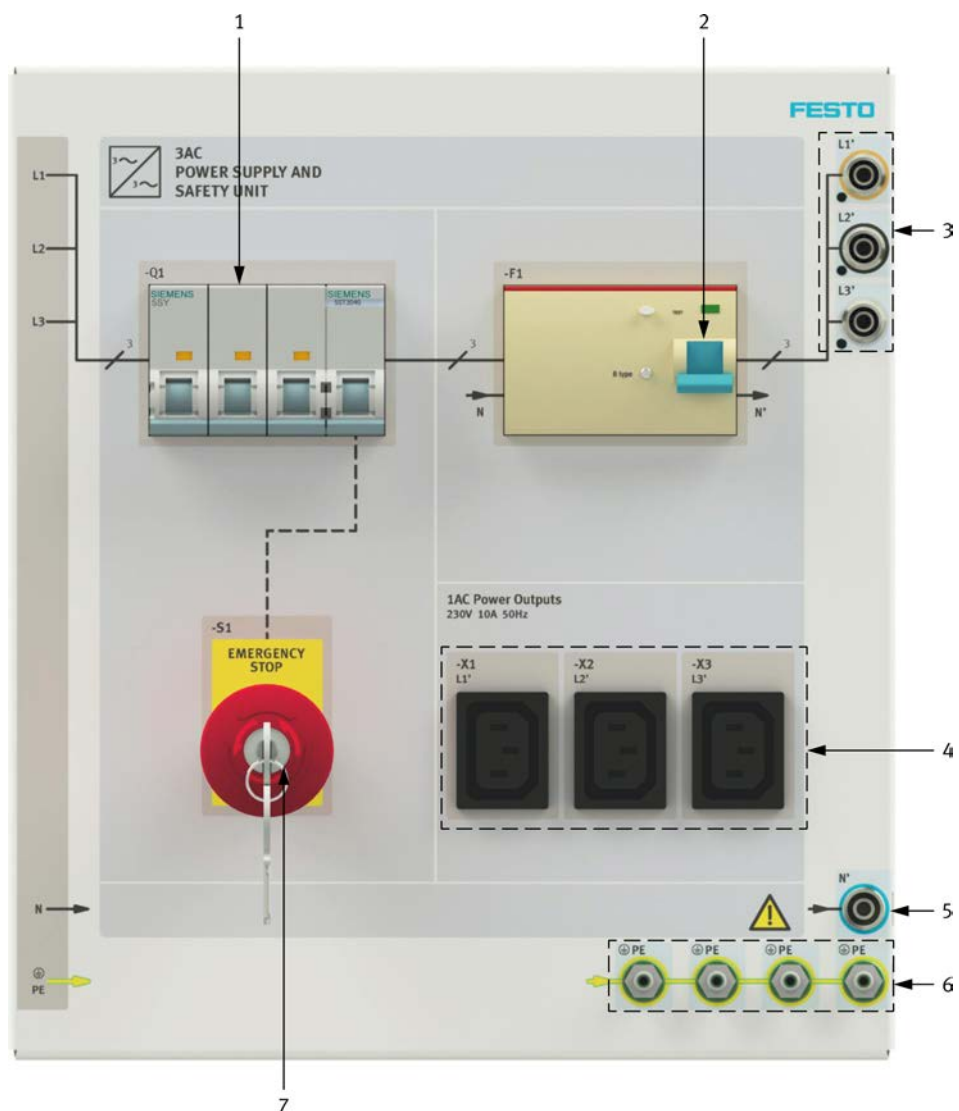





Figure 23: 3AC Power Supply and Safety Unit (594826).

**Table 10: Components of the 3AC Power Supply and Safety Unit (594826).**

Number	Component	Description
1	Three-pole circuit breaker with undervoltage release	Protection against short circuits.
2	Residual current circuit breaker	Protection that disconnects the circuit in case of current leakage.
3	Three-phase ac power output	Output terminals for each of the three lines (L1', L2', L3'). Near each terminal is an LED that lights up when that terminal is powered.
4	Single-phase ac power outlets	Standard power outlets.
5	Neutral output	Output terminal for the neutral line.
6	Protective earthing terminals	Terminals that provide protective earthing to the module and any connected module.
7	Lockable power-on switch and emergency stop button	Protection that removes power from the circuit when depressed. A key is required to reset the push button.

	 <b>WARNING</b>
	<p>Always connect a ground terminal of each module in your setup to a ground terminal of a 3AC Power Supply and Safety Unit.</p>

	 <b>CAUTION</b>
	<p>Do not leave the key in the power-on switch after locking or unlocking it. If you need to rapidly press on the emergency stop button, the presence of a key in the switch could cause a hand injury.</p>

**Table 11: Main specifications of the 3AC Power Supply and Safety Unit (594826).**

Parameter	Rating
Input power	<ul style="list-style-type: none"> <li>• Maximum current: 10 A</li> <li>• AC power network voltage and frequency: 230/400 V – 50 Hz</li> <li>• Electrical installation: 3 phases, star (wye) configuration including neutral and earth wires, protected by a 20 A circuit breaker.</li> </ul>
Output	3 AC 400 V, 50 Hz, 10 A (max)
Protections	Short circuit and overload
RCD protection	Type B, 30 mA
Outputs	<ul style="list-style-type: none"> <li>• Three-phase output via 4 mm safety sockets with pilot lights indicating voltage presence</li> <li>• Three single-phase IEC C13 outlets</li> </ul>
Mounting	Designed for DIN A4 mounting frames
Ingress protection rating	IP20
Electromagnetic compatibility	Group 1, Class A (industrial environment, EN 55011)
Dimensions (H x W x D)	297 x 266 x 140 mm (11.69 x 10.47 x 5.51 in)
Weight	4.6 kg (10.14 lb)
CE and UKCA markings	<ul style="list-style-type: none"> <li>• Low-Voltage Directive</li> <li>• EMC Directive</li> <li>• RoHS Directive</li> </ul>

### 3AC Power Supply and Safety Unit (8143155)

The 3AC Power Supply and Safety Unit provides power to circuits. It can operate as any of the following:

- Three-phase ac power source
- Single-phase ac power source
- 24 V dc power source

The 3AC Power Supply and Safety Unit provides power to and removes power from the circuits in the practical exercises. It must be connected to a three-phase power outlet. The module is equipped with a main circuit breaker and an emergency switch push button.

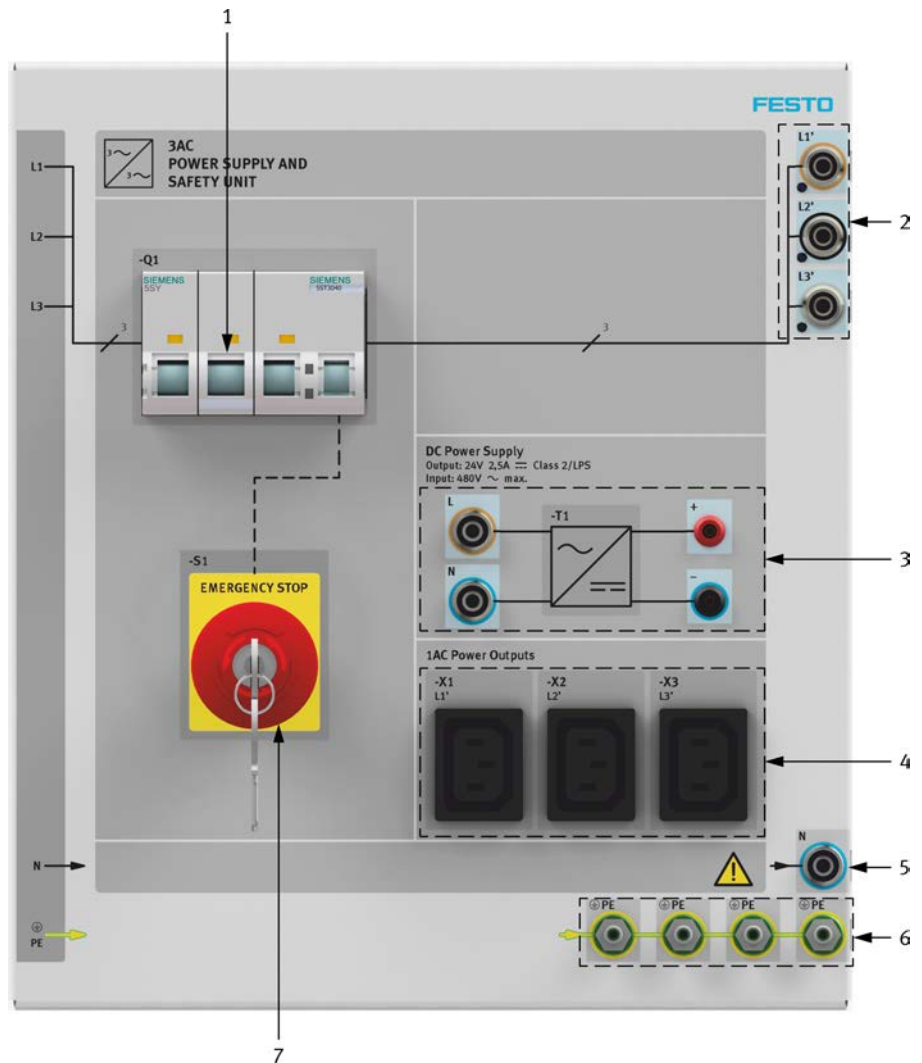





Figure 24: 3AC Power Supply and Safety Unit (8143155).

Table 12: Components of the 3AC Power Supply and Safety Unit (8143155).

Number	Component	Description
1	Three-pole circuit breaker with undervoltage release	Protection against short circuits.

Number	Component	Description
2	Three-phase ac power output	Output terminals for each of the three lines (L1', L2', L3'). Near each terminal is an LED that lights up when that terminal is powered.
3	24 V dc power output	A pair of positive and negative 2 mm terminals supply 24 V dc power through a rectifier.  In order for ac power to be supplied to the rectifier, electrical jumpers must be added between L1 and L, as well as between N and N. Removing these jumpers cuts off the supply of 24 V dc power.
4	Single-phase ac power outlets	Standard power outlets.
5	Neutral output	Output terminal for the neutral line.
6	Protective earthing terminals	Terminals that provide protective earthing to the module and any connected module.
7	Lockable power-on switch and emergency stop button	Protection that removes power from the circuit when depressed. A key is required to reset the push button.

	 <b>WARNING</b>
	<p>Always connect a ground terminal of each module in your setup to a ground terminal of a 3AC Power Supply and Safety Unit.</p>

	 <b>CAUTION</b>
	<p>Do not leave the key in the power-on switch after locking or unlocking it. If you need to rapidly press on the emergency stop button, the presence of a key in the switch could cause a hand injury.</p>

**Table 13: Main specifications of the 3AC Power Supply and Safety Unit (8143155).**

Components and parameters	Main specifications
Input power	<ul style="list-style-type: none"> <li>● Maximum current: 10 A</li> <li>● AC power network voltage and frequency: 230/400 V – 50 Hz</li> <li>● Electrical installation: 3 phases, star (wye) configuration including neutral and earth wires, protected by a 20 A circuit breaker.</li> <li>● Connection via CEE-plug 16 A.</li> </ul>
Output power	<ul style="list-style-type: none"> <li>● 3 AC 400 V, 50 Hz, 10 A (max)</li> <li>● 24 V DC, 2.5 A</li> </ul>
DC power supply input	480 V ac max.
Protections	Short circuit and overload
Outputs	<ul style="list-style-type: none"> <li>● Three-phase output via 4 mm safety sockets with pilot lights indicating voltage presence</li> <li>● 24 V DC output via 2 mm safety sockets</li> <li>● Three single-phase IEC C13 outlets</li> </ul>
Mounting	Designed for DIN A4 mounting frames
Ingress protection rating	IP20
Electromagnetic compatibility	Group 1, Class A (industrial environment, EN 55011)
Dimensions (H x W x D)	297 x 266 x 140 mm (11.69 x 10.47 x 5.51 in)
Weight	4.6 kg (10.14 lb)
CE and UKCA markings	<ul style="list-style-type: none"> <li>● Low-Voltage Directive</li> <li>● EMC Directive</li> <li>● RoHS Directive</li> </ul>

## 3AC Power Supply and Safety Unit (8143154)

The 3AC Power Supply and Safety Unit provides power to circuits. It can operate as any of the following:

- Three-phase ac power source
- Single-phase ac power source
- 24 V dc power source

The 3AC Power Supply and Safety Unit provides power to and removes power from the circuits in the practical exercises. It must be connected to a three-phase power outlet. The module is equipped with a main circuit breaker and an emergency switch push button.

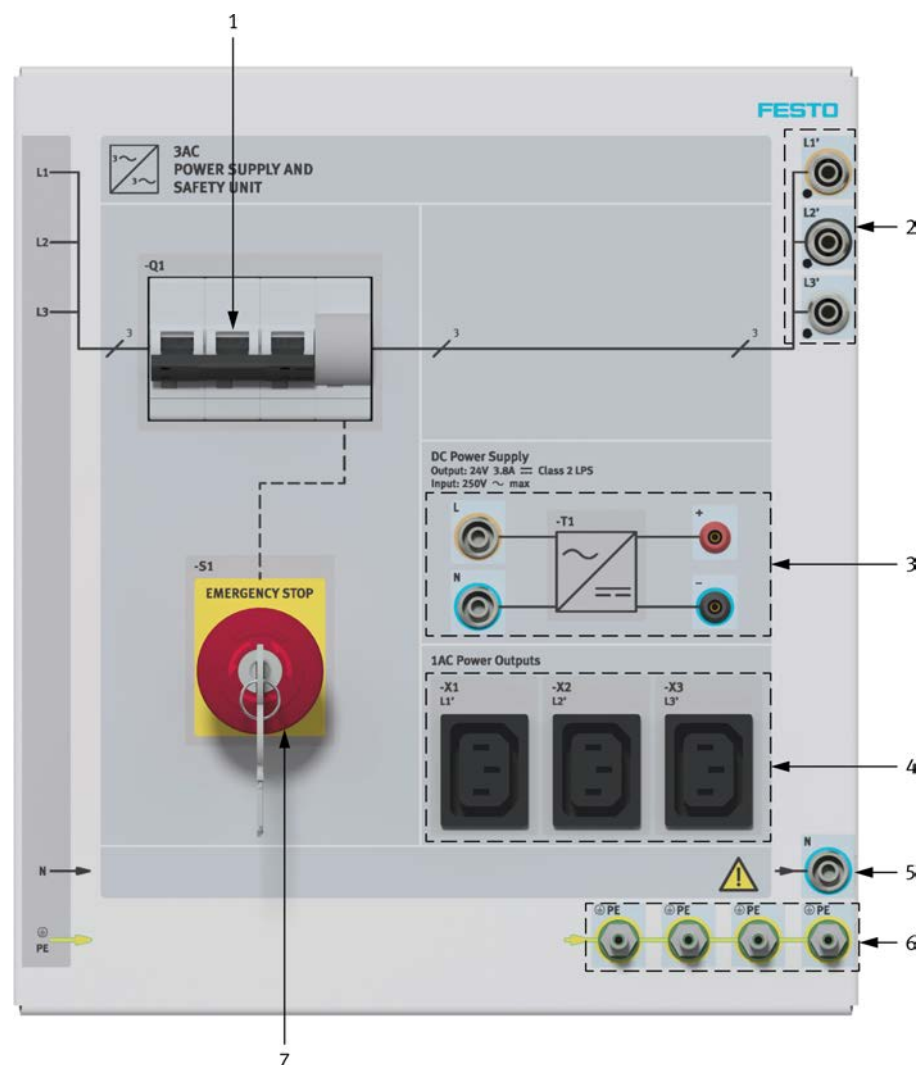





Figure 25: 3AC Power Supply and Safety Unit (8143154).

**Table 14: Components of the 3AC Power Supply and Safety Unit (8143154).**

Number	Component	Description
1	Three-pole circuit breaker with undervoltage release	Protection against short circuits.
2	Three-phase ac power output	Output terminals for each of the three lines (L1', L2', L3'). Near each terminal is an LED that lights up when that terminal is powered.
3	24 V dc power output	A pair of positive and negative 2 mm terminals supply 24 V dc power through a rectifier.  In order for ac power to be supplied to the rectifier, electrical jumpers must be added between L1 and L, as well as between N and N. Removing these jumpers cuts off the supply of 24 V dc power.
4	Single-phase ac power outlets	Standard power outlets.
5	Neutral output	Output terminal for the neutral line.
6	Protective earthing terminals	Terminals that provide protective earthing to the module and any connected module.
7	Lockable power-on switch and emergency stop button	Protection that removes power from the circuit when depressed. A key is required to reset the push button.

	 <b>WARNING</b>
	Always connect a ground terminal of each module in your setup to a ground terminal of a 3AC Power Supply and Safety Unit.

	 <b>CAUTION</b>
	Do not leave the key in the power-on switch after locking or unlocking it. If you need to rapidly press on the emergency stop button, the presence of a key in the switch could cause a hand injury.

**Table 15: Main specifications of the 3AC Power Supply and Safety Unit (8143154).**

Components and parameters	Main specifications
Input power	<ul style="list-style-type: none"> <li>● Maximum current: 10 A</li> <li>● AC power network voltage and frequency: 120/208 V – 60 Hz</li> <li>● Electrical installation: 3 phases, star (wye) configuration including neutral and earth wires, protected by a 20 A circuit breaker.</li> <li>● Connection via power cord with NEMA L21-20 plug (included).</li> </ul>
Output power	<ul style="list-style-type: none"> <li>● 3 AC 208 V, 60 Hz, 10 A (max)</li> <li>● 24 V DC, 3.8 A</li> </ul>
DC power supply input	250 V ac max.
Protections	Short circuit and overload
Outputs	<ul style="list-style-type: none"> <li>● Three-phase output via 4 mm safety sockets with pilot lights indicating voltage presence</li> <li>● 24 V DC output via 2 mm safety sockets</li> <li>● Three single-phase IEC C13 outlets</li> </ul>
Mounting	Designed for DIN A4 mounting frames
Ingress protection rating	IP20
Electromagnetic compatibility	Group 1, Class A (industrial environment, EN 55011)
Dimensions (H x W x D)	297 x 266 x 140 mm (11.69 x 10.47 x 5.51 in)
Weight	4.6 kg (10.14 lb)
CE and UKCA markings	<ul style="list-style-type: none"> <li>● Low-Voltage Directive</li> <li>● EMC Directive</li> <li>● RoHS Directive</li> </ul>

### Electrodynamometer Load (8147352)

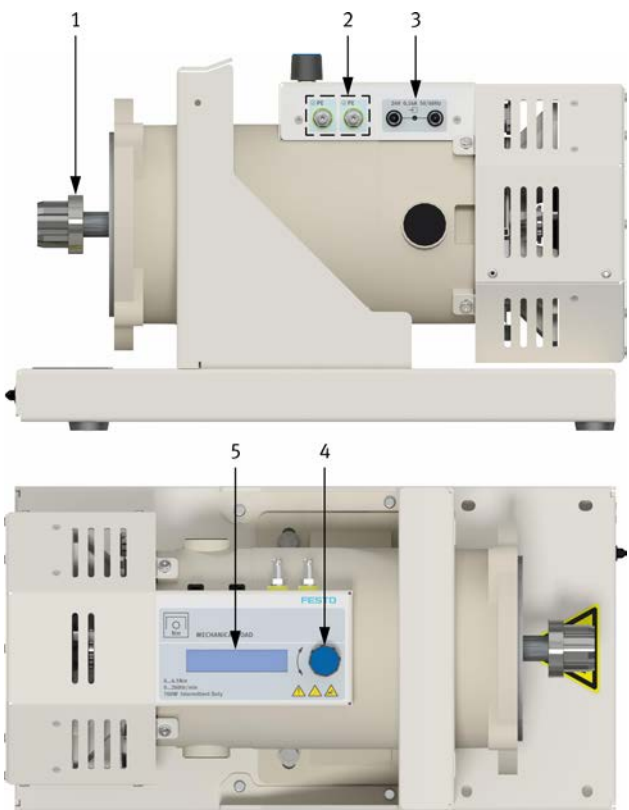

Figure 26: Electrodynamic Load module.

**Table 16: Description of the Electrodynamicometer Load module.**

Number	Component	Description
1	Shaft	The supplied flexible coupling can be installed on the shaft, allowing the mechanical coupling of the electrodynamicometer to a load.
2	Ground terminals	Terminals that provide grounding to the module and any connected module.
3	24 V ac auxiliary power input terminals	Input terminals for connection to the corresponding auxiliary power output terminals of a power supply. Power must be supplied to these terminals for the motor to operation.
4	Adjustment dial	Dial used to adjust various parameters of the electrodynamicometer.
5	Display	Display that shows the various menus of the electrodynamicometer.

The following videos show quick tutorials on how to use the Electrodynamicometer Load. For more information, consult the next sections.



**Powering the Electrodynamicometer Load.**

<https://lx.festo.com/media/cf84ea60cdc14afc9084b96ef47bb121>



**Adding torque.**

<https://lx.festo.com/media/f05af2c8069344958ea830f6dd5e28b2>



**Limiting speed.**

<https://lx.festo.com/media/42877a61ffe24a299b99f0fcde95d0a4>



**Switching between the speed and torque functions.**

<https://lx.festo.com/media/19b9b86a2e84411980085ac9a2a49125>



### Setting language and units.

<https://lx.festo.com/media/a09afb24fe824197ab0bc766c3e631b4>

## Main menu and Settings menu

The display of the Electrodynamicometer Load module can be used to control the module and display measured parameters. The following functions can be selected from the main menu of the module:

- **Torque function.** Allows the regulation of the braking torque at the shaft of the Electrodynamicometer Load. When selected, this function displays the braking torque setpoint used to control the Electrodynamicometer Load. The knob allows the modification of the braking torque setpoint.

When the Electrodynamicometer Load is started, this function also displays the measured speed and braking power.



- Braking torque values always include the internal friction of the Electrodynamicometer Load (bearing, fan, brushes, etc.). For this reason, the Electrodynamicometer Load can never display a null braking torque.
- The Electrodynamicometer Load operates on the principle of an induction brake. Therefore, the maximal braking torque cannot be reached when operating at low speeds.

- **Speed function.** Allows the speed regulation of the machine coupled to the Electrodynamicometer Load. It makes the Electrodynamicometer Load apply the braking torque required to slow down the coupled machine to the set specified speed. When selected, this function displays the speed setpoint used to control the Electrodynamicometer Load. The knob allows the modification of the speed setpoint.



The Electrodynamicometer Load can only apply a braking (negative) torque to decelerate the coupled machine to the specified speed setpoint. It cannot apply a positive torque to accelerate the coupled machine to the specified speed setpoint.

When the Electrodynamicometer Load is started, this function also displays the measured braking torque and power.

- **Power function.** Displays the braking power at the shaft of the Electrodynamicometer Load.



- Pushing the knob while the arrow points at Speed or Torque selects the corresponding function.
- While changing the speed or torque setpoint, pressing the knob for 2 seconds divides the increment of the knob by 10. This allows the fine tuning of the setpoint.
- When a parameter is displayed in capital letters, it indicates that the corresponding control function is currently selected.
- When the Electrodynamicometer Load is stopped, any indicated setpoint is the setpoint that will be used for control once the Electrodynamicometer Load is started.

A Settings menu is also available from the main menu of the module. It allows the setting of the following parameters:

- **Language.** Allows the selection of the preferred display language.
- **Units.** Allows the selection of the preferred system of units for the display of torque values.
- **Calibration.** Starts the calibration procedure of the Electrodynamicometer Load. This procedure requires a variable-speed motor to bring the Electrodynamicometer Load to 400 r/min in a first step and 1200 r/min in a second step. It does not require any speed regulation.

To perform the calibration process, follow the steps indicated on the display. The calibration routine automatically detects when the required speeds are reached and automatically proceeds to the next step. When all required values are acquired, the display will indicate that the calibration is finished and return to the Settings menu.

## Display color

The display of the Electrodynamicometer Load module changes color to indicate the current status of the module. The meaning of each display color is described below:

- **Blue.** Indicates normal operating conditions.
- **Purple.** Braking torque is limited to prevent braking power over 700 W.
- **Yellow.** Indicates that the Electrodynamicometer Load has reached its maximal braking torque for the speed at which it currently operates, and so, cannot reach the specified braking torque or speed setpoint.
- **Red.** Indicates that a fault has occurred. The display specifies the nature of the fault. When in this status, the Electrodynamicometer Load stops braking.

To clear the fault, power cycle the module by disconnecting and reconnecting its power cord. To clear an overheating fault, wait for the Electrodynamicometer Load to cool down to the appropriate temperature.

- **Green.** Indicates that a serial channel is open. This display color appears after pressing the knob for 10 seconds.

The serial channel is not useful for didactic purposes. It is recommended not to operate the Electrodynamometer Load in this condition. To clear this condition, power cycle the module by disconnecting and reconnecting its power cord.

## Main specifications and features

**Table 17: Main specifications and features of the Electrodynamometer Load.**

Parameters and features	Specification
Maximum braking torque	4.5 N·m (39.8 lbf·in)
Maximum speed	± 2600 r/min
Maximum braking power	700 W
Nominal braking power	250 W
Auxiliary power input (ac)	24 V – 0.16 A, 50/60 Hz
Protection features	<ul style="list-style-type: none"> <li>● Power limiter (700 W)</li> <li>● Mother board overheat protection</li> <li>● Motor overheat protection</li> <li>● Overspeed disconnect protection</li> <li>● Bus transient overvoltage protection</li> </ul>
Ingress protection rating	IP20
Electromagnetic compatibility	Group 1, Class A (industrial environment, EN 55011)
Dimensions (H x W x D)	TBD x TBD x TBD mm (TBD x TBD x TBD in)
Weight	TBD kg (TBD lb)
CE and UKCA markings	<ul style="list-style-type: none"> <li>● Machine Directive</li> <li>● Low-Voltage Directive</li> <li>● EMC Directive</li> <li>● RoHS Directive</li> </ul>

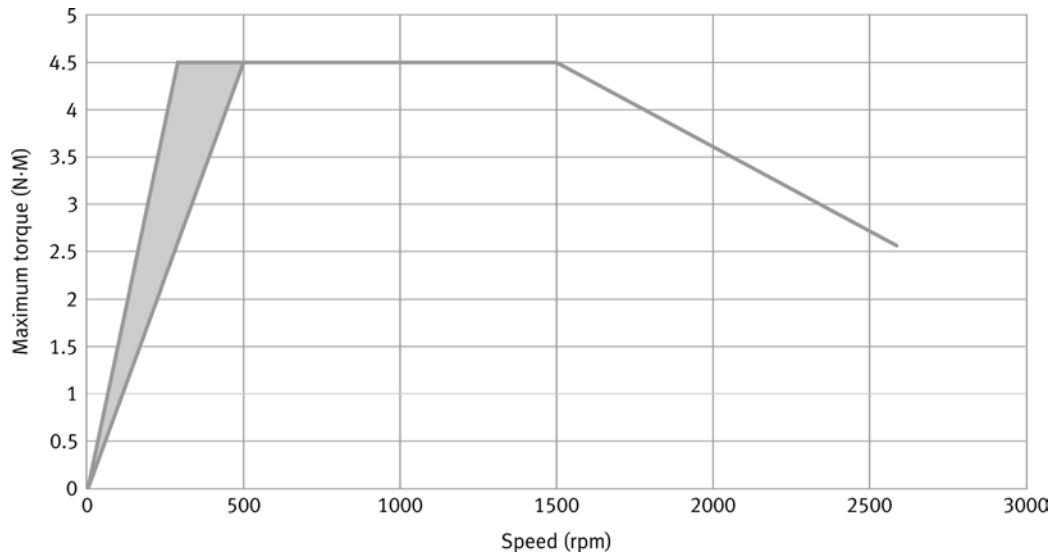

Figure 27: Maximum braking torque as a function of the operating speed.

## Squirrel-Cage Induction Machine (8143697)

The Squirrel-Cage Induction Machine is a four-pole, three-phase, squirrel-cage induction machine. It is configured as a six-lead motor and is designed to be connected in a delta (triangle) configuration.

For safety reasons, the motor windings are by default internally disconnected to prevent the motor from running. The full windings are connected to the front panel terminals only if the following conditions are met:

1. One of the two 24 V ac auxiliary power input terminals is connected to a corresponding output terminal on a suitable power supply. When this requirement is met, a blue LED on the motor front panel turns on. The two auxiliary power input terminals of the motor are parallel-wired so the same power supply can be daisy-chained to additional devices, such as a dynamometer.
2. The appropriate protective guard is in place. As long as this requirement is not met, the red LED on the bottom right corner of the connection box remains on.

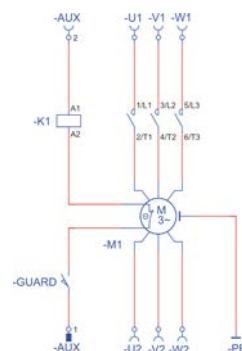



Figure 28: Motor protection circuit diagram.

	 <b>WARNING</b>
	<p>Never operate the Squirrel-Cage Induction Machine without the protective guard securely in place.</p>

Fault switches are located under the motor, allowing instructors to add faults to the motor operation for troubleshooting purposes.

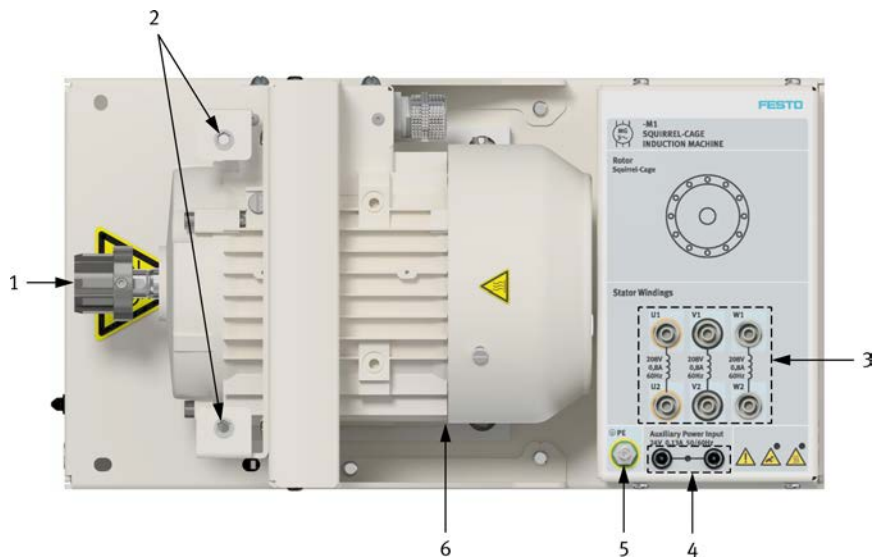



Figure 29: Squirrel-Cage Induction Machine.

	 <b>WARNING</b>
	<p>Always connect a ground terminal of each module in your setup to a ground terminal of a Power Supply and Safety Unit.</p>

<b>NOTICE</b>
<p>When coupling the motor with the inertia wheel or the dynamometer, make sure to install the key in the motor shaft keyseat before assembly. When the inertia wheel or dynamometer coupling is well seated on the motor shaft, use the setscrew to secure it in place. Failure to do so can cause damage to the equipment.</p>

Table 18: Components of the Squirrel-Cage Induction Machine.

Number	Component	Description
1	Motor shaft	The supplied flexible coupling can be installed on the motor shaft, allowing the mechanical coupling of the motor to a load.

Number	Component	Description
2	Screw holes for securing a protective guard	The screw holes allow the protective guard to be secured on the motor. This ensures that the protective guard cannot be removed before the motor is completely stopped.
3	Stator winding terminals	Input and output terminals for the stator windings of the motor. Consult the relevant course or the manufacturer's documentation for more information on the winding connections.
4	24 V ac auxiliary power input terminals	Input terminals for connection to the corresponding auxiliary power output terminals of a power supply. Power must be supplied to these terminals for the motor to operation. See the "Description" section for more information.
5	Ground connector	Terminals that provide grounding to the module and any connected module.
6	Motor	See the "Specifications" section for the main motor specifications. Alternately, the nameplate on the motor indicates the motor specifications.

**Table 19: Main specifications of the Squirrel-Cage Induction Machine.**

Components and parameters	Main specifications
Nominal speed	<ul style="list-style-type: none"> <li>● 1595 r/min at 60 Hz</li> <li>● 1330 r/min at 50 Hz</li> </ul>
Nominal power output	0.25 kW (0.33 hp), 3 AC 208 V, 60 Hz, 1.38 A
Nominal efficiency	<ul style="list-style-type: none"> <li>● 68% at 60 Hz</li> <li>● 61% at 50 Hz</li> </ul>
Connection	Delta
Auxiliary power input	24 V AC, 0.13 A (required for safety protections)

Components and parameters	Main specifications
Connectors	4 mm safety sockets
Ingress protection rating	IP20
Electromagnetic compatibility	Group 1, Class A (industrial environment, EN 55011)
Dimensions (H x W x D)	211 x 200 x 370 mm (8.31 x 7.87 x 14.57 in)
Weight	TBD kg (TBD lb)
CE and UKCA markings	<ul style="list-style-type: none"> <li>● Machine Directive</li> <li>● Low-Voltage Directive</li> <li>● EMC Directive</li> <li>● RoHS Directive</li> </ul>

## Squirrel-Cage Induction Machine (8143698)

The Squirrel-Cage Induction Machine is a four-pole, three-phase, squirrel-cage induction machine. It is configured as a six-lead motor and is designed to be connected in a delta (triangle) configuration.

For safety reasons, the motor windings are by default internally disconnected to prevent the motor from running. The full windings are connected to the front panel terminals only if the following conditions are met:

1. One of the two 24 V ac auxiliary power input terminals is connected to a corresponding output terminal on a suitable power supply. When this requirement is met, a blue LED on the motor front panel turns on. The two auxiliary power input terminals of the motor are parallel-wired so the same power supply can be daisy-chained to additional devices, such as a dynamometer.
2. The appropriate protective guard is in place. As long as this requirement is not met, the red LED on the bottom right corner of the connection box remains on.

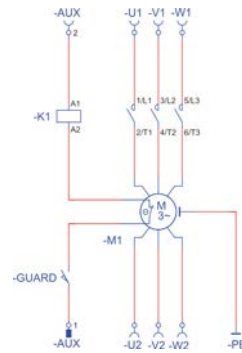



Figure 30: Motor protection circuit diagram.

	 <b>WARNING</b>
<p>Never operate the Squirrel-Cage Induction Machine without the protective guard securely in place.</p>	

Fault switches are located under the motor, allowing instructors to add faults to the motor operation for troubleshooting purposes.

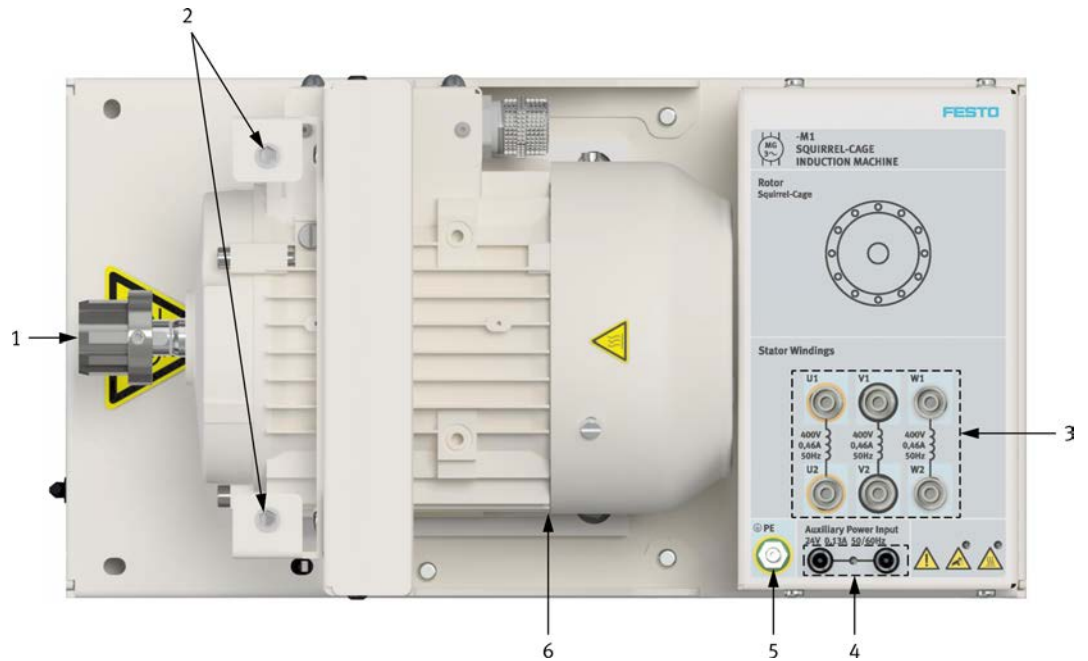



Figure 31: Squirrel-Cage Induction Machine.

	 <b>WARNING</b>
	<p>Always connect a ground terminal of each module in your setup to a ground terminal of a Power Supply and Safety Unit.</p>

<b>NOTICE</b>
<p>When coupling the motor with the inertia wheel or the dynamometer, make sure to install the key in the motor shaft keyseat before assembly. When the inertia wheel or dynamometer coupling is well seated on the motor shaft, use the setscrew to secure it in place. Failure to do so can cause damage to the equipment.</p>

Table 20: Components of the Squirrel-Cage Induction Machine.

Number	Component	Description
1	Motor shaft	The supplied flexible coupling can be installed on the motor shaft, allowing the mechanical coupling of the motor to a load.
2	Screw holes for securing a protective guard	The screw holes allow the protective guard to be secured on the motor. This ensures that the protective guard cannot be removed before the motor is completely stopped.

Number	Component	Description
3	Stator winding terminals	Input and output terminals for the stator windings of the motor. Consult the relevant course or the manufacturer's documentation for more information on the winding connections.
4	24 V ac auxiliary power input terminals	Input terminals for connection to the corresponding auxiliary power output terminals of a power supply. Power must be supplied to these terminals for the motor to operation. See the "Description" section for more information.
5	Ground connector	Terminals that provide grounding to the module and any connected module.
6	Motor	See the "Specifications" section for the main motor specifications. Alternately, the nameplate on the motor indicates the motor specifications.

**Table 21: Main specifications of the Squirrel-Cage Induction Machine.**

Components and parameters	Main specifications
Nominal speed	<ul style="list-style-type: none"> <li>● 1595 r/min at 60 Hz</li> <li>● 1330 r/min at 50 Hz</li> </ul>
Nominal power output	0.25 kW (0.33 hp), 3 AC 380 – 415 V, 60 Hz, 0.75 – 0.69 A 0.25 kW (0.33 hp), 3 AC 380 – 415 V, 50 Hz, 0.83 – 0.76 A
Nominal efficiency	<ul style="list-style-type: none"> <li>● 68% at 60 Hz</li> <li>● 61% at 50 Hz</li> </ul>
Connection	Delta
Auxiliary power input	24 V AC, 0.13 A (required for safety protections)
Connectors	4 mm safety sockets
Ingress protection rating	IP20
Electromagnetic compatibility	Group 1, Class A (industrial environment, EN 55011)
Dimensions (H x W x D)	211 x 200 x 370 mm (8.31 x 7.87 x 14.57 in)
Weight	TBD kg (TBD lb)
CE and UKCA markings	<ul style="list-style-type: none"> <li>● Machine Directive</li> <li>● Low-Voltage Directive</li> <li>● EMC Directive</li> <li>● RoHS Directive</li> </ul>

## Control and Pilot Devices (8140123)

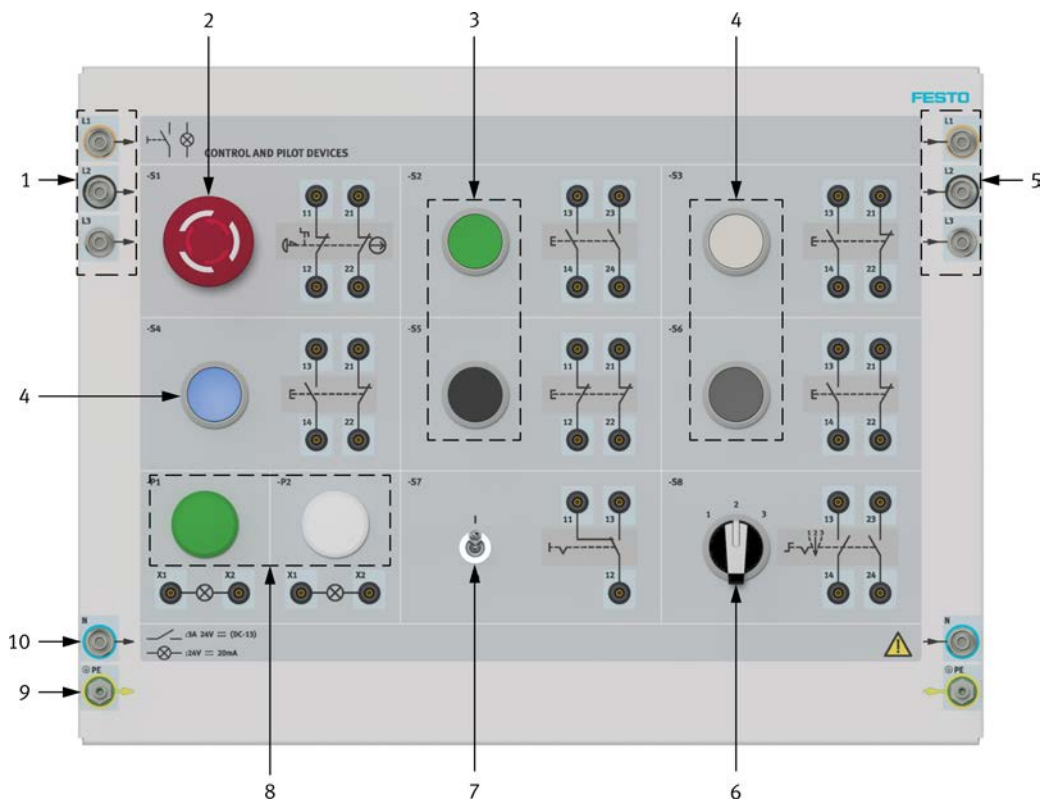

Figure 32: Control and Pilot Devices.

The Control and Pilot Devices module includes several lights and switches that can be used in a control circuit to activate devices and monitor their state. All devices of the module operate at a low voltage suitable for control circuits.

Table 22: Components of the Control and Pilot Devices.

Number	Name	Description
1	Line input terminals	Input terminals for each of the three lines (L1, L2, L3) coming from the power supply.
2	Mushroom push button	A maintained mushroom push button with two normally closed contacts.
3	Double-pole, single-throw push buttons	Double-pole, single-throw push buttons. One normally open and one normally closed.
4	Push buttons	A series of three push buttons. Each of them with one normally open contact and one normally closed contact.

Number	Name	Description
5	Line output terminals	Output terminals for each of the three lines (L1, L2, L3) going to the circuit. Near each terminal is an LED that lights up when that terminal is powered.
6	Selector switch	Selector switch with a normally open and a normally closed contact.
7	Toggle switch	Single-pole, double-throw toggle switch.
8	Lights	Two indicating lights used for status monitoring.
9	Ground connectors	Terminals that provide grounding to the module and any connected module.
10	Neutral terminals	Input and output terminals for the neutral line.

**Table 23: Main specifications of the Control and Pilot Devices.**

Components and parameters	Main specifications
Control voltage	24 V DC, 3 A (DC-13)
Three-phase power bus	415 V (max)
Mounting	Designed to be used in a DIN A4 mounting frame
Connectors	Connections via 4 mm safety sockets for power and 2 mm safety sockets for control (24 V DC)
Ingress protection rating	IP20
Electromagnetic compatibility	Group 1, Class A (industrial environment, EN 55011)
Dimensions (H x W x D)	297 x 399 x 90 mm (11.69 x 15.71 x 3.54 in)
Weight	TBD kg (TBD lb)

Components and parameters	Main specifications
CE and UKCA markings	<ul style="list-style-type: none"> <li>• Low-Voltage Directive</li> <li>• EMC Directive</li> <li>• RoHS Directive</li> </ul>

## Disconnect Switch (8140373)

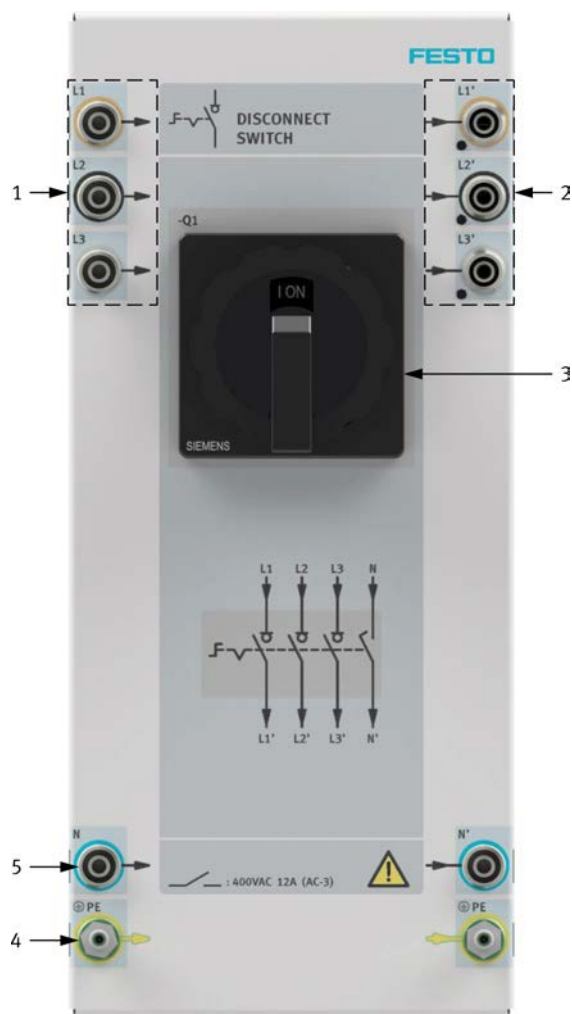

Figure 33: Disconnect Switch.

The disconnect switch should be used in all exercises between the power source and the power circuit. It allows to safely connect and disconnect equipment from the power source. In the off position a hasp and a padlock can be inserted in a hole to lockout the switch.

**Table 24: Components of the Disconnect Switch.**

Number	Name	Description
1	Line inputs	Inputs for each of the three lines (L1, L2, L3) coming from the power supply.
2	Line output terminals	Output terminals for each of the three lines (L1', L2', L3') going to the circuit. Near each terminal is an LED that lights up when that terminal is powered.
3	Rotary knob	Rotary knob with a hole to insert a hasp or padlock to lock the switch in the off position.
4	Ground connectors	For safety reasons, all ground connectors should be interconnected at all times.
5	Neutral connectors	Input and output connectors for the neutral line.

**Table 25: Main specifications of the Disconnect Switch.**

Components and parameters	Main specifications
Input/Output power	3 AC 400 V, 12 A (AC-3)
Scope of delivery	One lockout hasp, two padlocks and two lockout identification tags
Mounting	Designed to be used in a DIN A4 mounting frame
Connectors	Connections via 4 mm safety sockets
Ingress protection rating	IP20
Electromagnetic compatibility	Group 1, Class A (industrial environment, EN 55011)
Dimensions (H x W x D)	297 x 133 x 90 mm (11.69 x 5.24 x 3.54 in)
Weight	TBD kg (TBD lb)

Components and parameters	Main specifications
CE and UKCA markings	<ul style="list-style-type: none"> <li>● Low-Voltage Directive</li> <li>● EMC Directive</li> <li>● RoHS Directive</li> </ul>

## Rotary Cam Switch (8140444)

The Rotary Cam Switch allows switching of a motor phase sequence, and thus its direction of rotation. The following switch positions are available.

- **Forward.** The phase sequence of the line output terminals is identical to that of the line input terminals. Any motor connected to the Rotary Cam Switch turns in its default direction of rotation.
- **Stop.** The circuit between the line input terminals and the line output terminals is open. Therefore, the line output terminals do not supply power and any motor connected to the Rotary Cam Switch progressively stops.
- **Reverse.** Lines 1 and 2 are inverted from the line input terminals to the line output terminals. This reverses the direction of rotation of any motor connected to the Rotary Cam Switch.

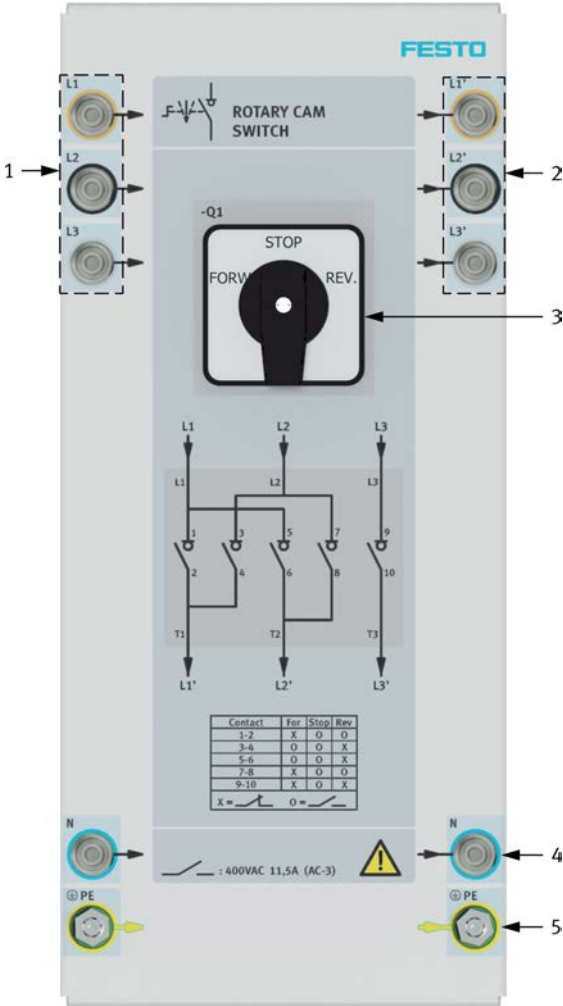



Figure 34: Rotary Cam Switch.

**Table 26: Components of the Rotary Cam Switch.**

Number	Name	Description
1	Line input terminals	Input terminals for each of the three lines (L1, L2, L3) coming from the power supply.
2	Line output terminals	Output terminals for each of the three lines (L1', L2', L3') going to the circuit. Near each terminal is an LED that lights up when that terminal is powered.
3	Rotary knob	Rotary knob that allows switching between the forward, stop, and reverse positions.
4	Neutral terminals	Input and output terminals for the neutral line.
5	Ground terminals	Terminals that provide grounding to the module and any connected module.

	 <b>WARNING</b>
	<p>Always connect a ground terminal of each module in your setup to a ground terminal of a Power Supply and Safety Unit.</p>

**Table 27: Main specifications of the Rotary Cam Switch.**

Components and parameters	Main specifications
Input/Output power	3 AC 400 V, 11.5 A (AC-3)
Mounting	Designed to be used on a table or in a DIN A4 mounting frame
Connectors	Connections via 4 mm safety sockets
Ingress protection rating	IP20
Electromagnetic compatibility	Group 1, Class A (industrial environment, EN 55011)
Dimensions (H x W x D)	297 x 133 x 90 mm (11.69 x 5.24 x 3.54 in)
Weight	TBD kg (TBD lb)
CE and UKCA markings	<ul style="list-style-type: none"> <li>● Low-Voltage Directive</li> <li>● EMC Directive</li> <li>● RoHS Directive</li> </ul>

## Starting Resistors (8142976)

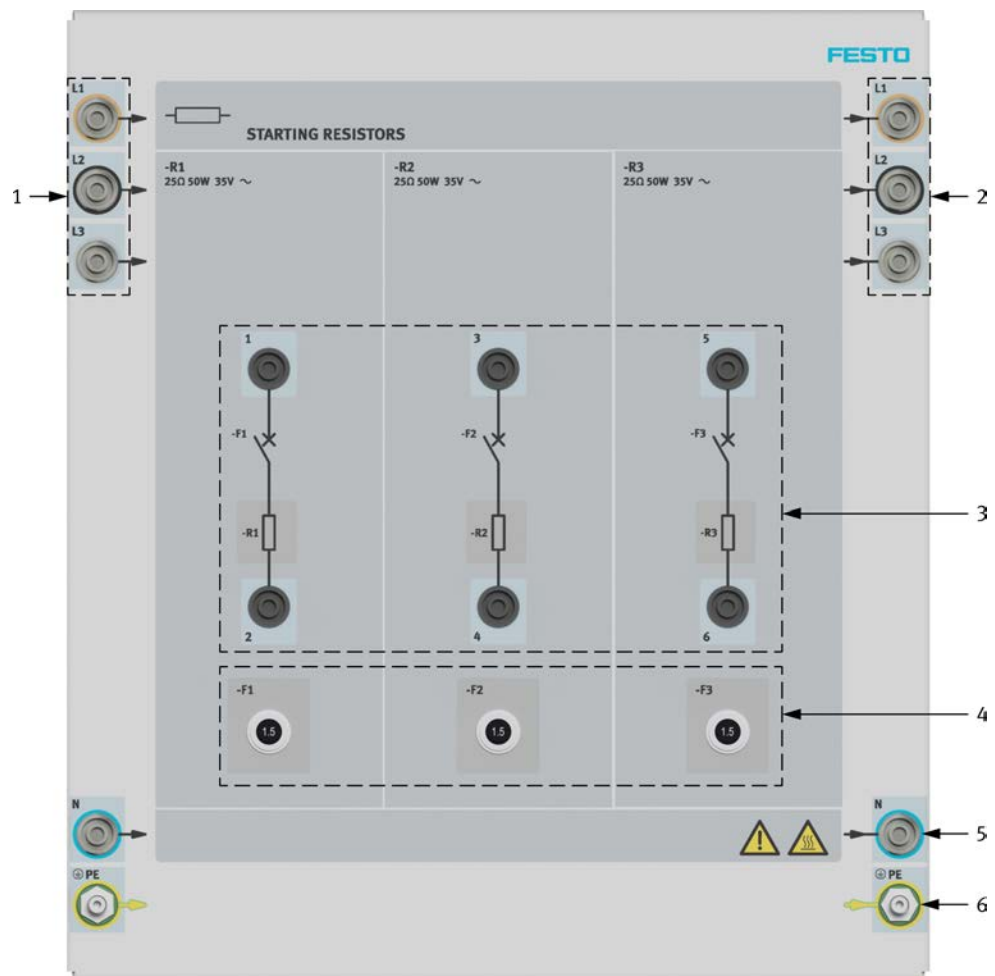



Figure 35: Starting Resistors.

The Starting Resistors module consists of three 25 Ω resistors that can be placed in series with the power lines of a motor to reduce the voltage applied at start-up.

**Table 28: Components of the Starting Resistors.**

Number	Name	Description
1	Line input terminals	Input terminals for each of the three lines (L1, L2, L3) coming from the power supply.
2	Line output terminals	Output terminals for each of the three lines (L1', L2', L3') going to the circuit.
3	Resistors	Three resistors of each 25 Ω.
4	Circuit breakers	Three circuit breakers, each protecting a resistor.
5	Neutral terminals	Input and output terminals for the neutral line.
6	Ground terminals	Terminals that provide grounding to the module and any connected module.

	 <b>WARNING</b>
	<p>Always connect a ground terminal of each module in your setup to a ground terminal of a Power Supply and Safety Unit.</p>

**Table 29: Main specifications of the Starting Resistors.**

Components and parameters	Main specifications
Each resistor	25 Ω, 250 V AC, 100 W
Three-phase power bus	3AC 415 V (max)
Mounting	Designed to be used in a DIN A4 mounting frame
Connectors	Connections via 4 mm safety sockets
Ingress protection rating	IP20
Electromagnetic compatibility	Group 1, Class A (industrial environment, EN 55011)

Components and parameters	Main specifications
Dimensions (H x W x D)	297 x 266 x 140 mm (11.69 x 10.47 x 5.51 in)
Weight	TBD kg (TBD lb)
CE and UKCA markings	<ul style="list-style-type: none"> <li>● Low-Voltage Directive</li> <li>● EMC Directive</li> <li>● RoHS Directive</li> </ul>

## Starting Resistors (8144625)

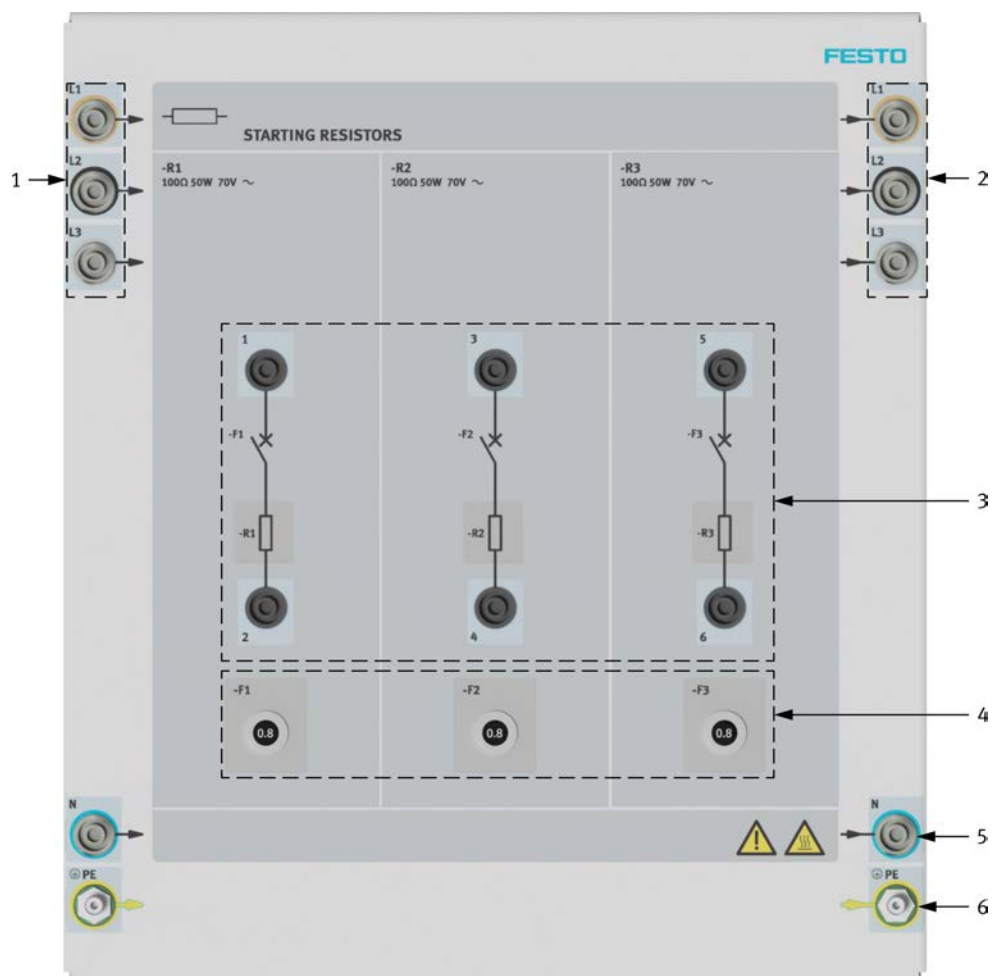



Figure 36: Starting Resistors.

The Starting Resistors module consists of three 100 Ω resistors that can be placed in series with the power lines of a motor to reduce the voltage applied at start-up.

Table 30: Components of the Starting Resistors.

Number	Name	Description
1	Line input terminals	Input terminals for each of the three lines (L1, L2, L3) coming from the power supply.
2	Line output terminals	Output terminals for each of the three lines (L'1, L'2, L'3) going to the circuit.
3	Resistors	Three resistors of each 100 Ω.

Number	Name	Description
4	Circuit breakers	Three circuit breakers, each protecting a resistor.
5	Neutral terminals	Input and output terminals for the neutral line.
6	Ground terminals	Terminals that provide grounding to the module and any connected module.

	 <b>WARNING</b>
	<p>Always connect a ground terminal of each module in your setup to a ground terminal of a Power Supply and Safety Unit.</p>

**Table 31: Main specifications of the Starting Resistors.**

Components and parameters	Main specifications
Each resistor	100 Ω, 250 V AC, 100 W
Three-phase power bus	3AC 415 V (max)
Mounting	Designed to be used in a DIN A4 mounting frame
Connectors	Connections via 4 mm safety sockets
Ingress protection rating	IP20
Electromagnetic compatibility	Group 1, Class A (industrial environment, EN 55011)
Dimensions (H x W x D)	297 x 266 x 140 mm (11.69 x 10.47 x 5.51 in)
Weight	TBD kg (TBD lb)
CE and UKCA markings	<ul style="list-style-type: none"> <li>● Low-Voltage Directive</li> <li>● EMC Directive</li> <li>● RoHS Directive</li> </ul>

## Contactor (8140795)

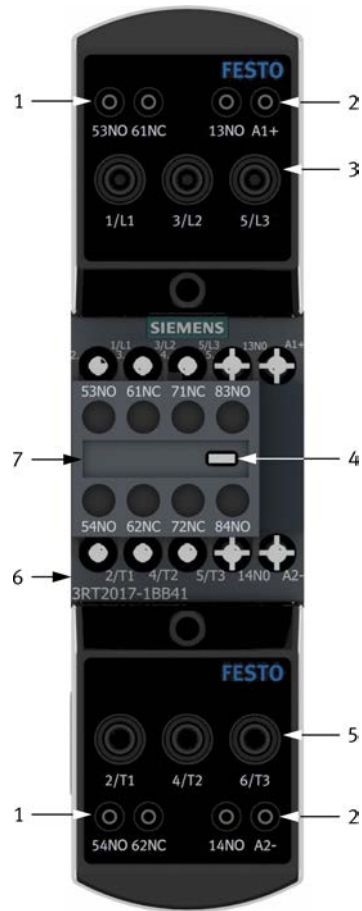

Figure 37: Contactor, with a set of auxiliary contacts.

The contactor, which also has auxiliary contact, is a switch that can be controlled via its low-voltage control circuit. It can be used, for example, to start a motor.

Table 32: Components of the Contactor.

Number	Name	Description
1	Auxiliary contact terminals	Terminals of the normally open and normally closed auxiliary contacts. The first two contact are those of the auxiliary switch installed on top of the contactor. These contacts are mechanically actuated when the contactor is actuated. The last normally open contact is the built-in auxiliary contact of the contactor.
2	Control circuit terminals	Control circuit terminals. When a control voltage is applied to the control terminals (A1+/A2-), the contactor is actuated.

Number	Name	Description
3	Line input terminals	Input terminals for each of the three lines (L1, L2, L3) coming from the power supply.
4	Manual actuator	Allows the manual actuation of the contactor by moving the armature.
5	Line output terminals	Output terminals for each of the three lines (T1, T2, T3) going to the circuit.
6	Contactor terminals	Terminals for the Siemens three-pole power contactor.
7	Auxiliary switch terminals	Auxiliary switch that can be installed on top of a contactor.

**Table 33: Main specifications of the Contactor.**

Components and parameters	Main specifications
Power rating	3AC 415 V, 10 A, 4 kW
Auxiliary contacts (5)	24 V DC, 4 A, 3 NO + 2 NC
Control	24 V DC with voltage limiter included
Connectors	Connections via 4 mm safety sockets for power and 2 mm sockets for control and auxiliary contacts (24 V DC)
Ingress protection rating	IP20
Electromagnetic compatibility	Group 1, Class A (industrial environment, EN 55011)
Dimensions (H x W x D)	TBD x TBD x TBD mm (TBD x TBD x TBD in)
Weight	TBD kg (TBD lb)
CE and UKCA markings	<ul style="list-style-type: none"> <li>● Low-Voltage Directive</li> <li>● EMC Directive</li> <li>● RoHS Directive</li> </ul>

### Control Relay (8140801)

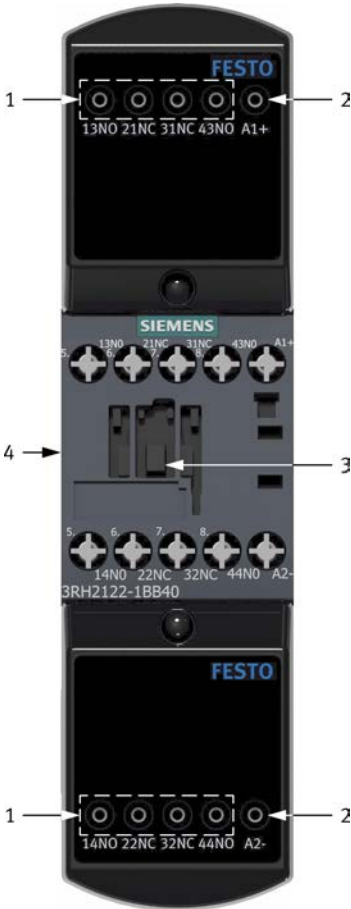

Figure 38: Control Relay.

The Control Relay is a switch controlled via its low-voltage control circuit. Its contacts can activate different devices in a control circuit.

**Table 34: Components of the Control Relay.**

Number	Name	Description
1	Contact terminals	Terminals of the normally open and normally closed contacts. These contacts are mechanically actuated when the control relay is actuated.
2	Control circuit terminals	When a control voltage is applied to the control terminals (A1+/A2-), the control relay is actuated.
3	Manual actuator	Allows the manual actuation of the control relay by moving the armature.
4	Control relay	Siemens control relay.

**Table 35: Main specifications of the Control Relay.**

Components and parameters	Main specifications
Output Contacts (4)	24 V DC, 4 A, 2 NO + 2 NC
Control	24 V DC
Connectors	Connections via 2 mm sockets (24 V DC)
Ingress protection rating	IP20
Electromagnetic compatibility	Group 1, Class A (industrial environment, EN 55011)
Dimensions (H x W x D)	TBD x TBD x TBD mm (TBD x TBD x TBD in)
Weight	TBD kg (TBD lb)
CE and UKCA markings	<ul style="list-style-type: none"> <li>● Low-Voltage Directive</li> <li>● EMC Directive</li> <li>● RoHS Directive</li> </ul>

## Motor Starter Protector (8140796)

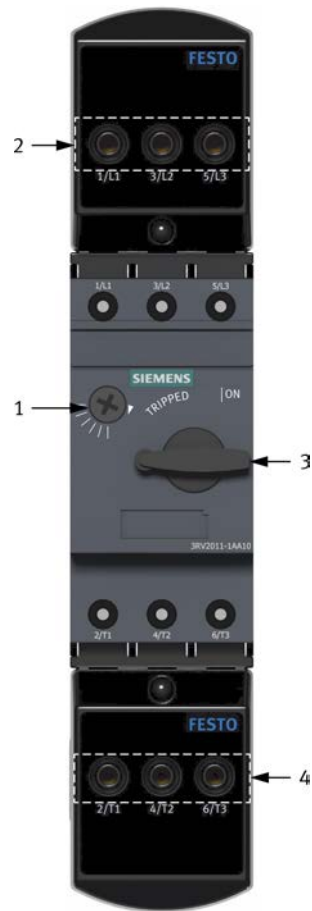
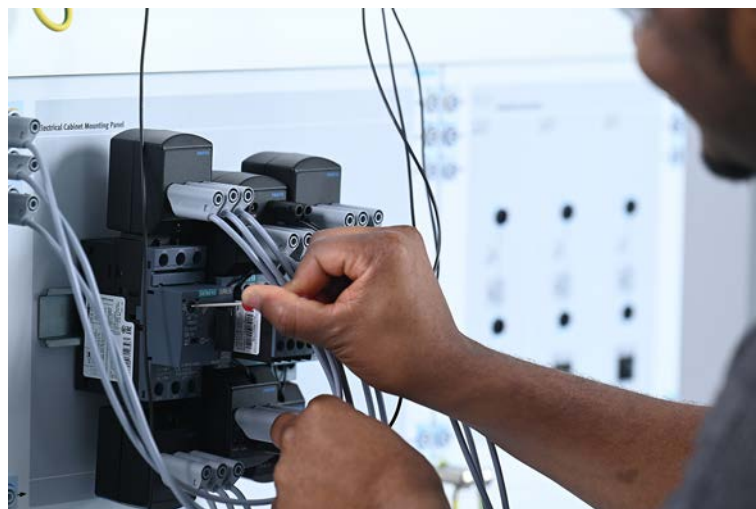

Figure 39: Motor Starter Protector.

The Motor Starter Protector is a thermal-overload circuit-breaker used for manual motor starting and protection. An adjustable rotating button allows the adjustment of the overload current.

**Table 36: Components of the Motor Starter Protector.**

Number	Name	Description
1	Overload current rotating button	Adjustment button for the current rating of the overload protection on the device.
2	Line input terminals	Inputs for each of the three lines (L1, L2, L3) coming from the power supply.
3	On/Off selector switch	Selector switch that turns on or off any motor connected to the Motor Starter Protector. When the device trips, the selector switch is automatically set to Tripped. To reset the device, set the selector switch to Off. The reset only occurs once the thermal overload has sufficiently cooled down. The cause of the tripping should be investigated and cleared before powering the system on again.
4	Line output terminals	Output terminals for each for the three lines (T1, T2, T3) going to the circuit.



**Figure 40: Adjusting the FLA on a motor starter protector.**



**Adjusting the FLA on a motor starter protector.**

<https://lx.festo.com/media/935b1793174742b3bd73604b63096b12>

**Table 37: Main specifications of the Motor Starter Protector.**

<b>Components and parameters</b>	<b>Main specifications</b>
Power rating	3 AC 415 V, 550 W
Adjustable overload release (CLASS 10)	1.1 to 1.6 A
Trip class	CLASS 10
Short-circuit current breaking capacity	100 kA (magnetic)
Connectors	Connections via 4 mm safety sockets
Ingress protection rating	IP20
Electromagnetic compatibility	Group 1, Class A (industrial environment, EN 55011)
Dimensions (H x W x D)	TBD x TBD x TBD mm (TBD x TBD x TBD in)
Weight	TBD kg (TBD lb)
CE and UKCA markings	<ul style="list-style-type: none"> <li>● Low-Voltage Directive</li> <li>● EMC Directive</li> <li>● RoHS Directive</li> </ul>

## Motor Starter Protector (8140797)

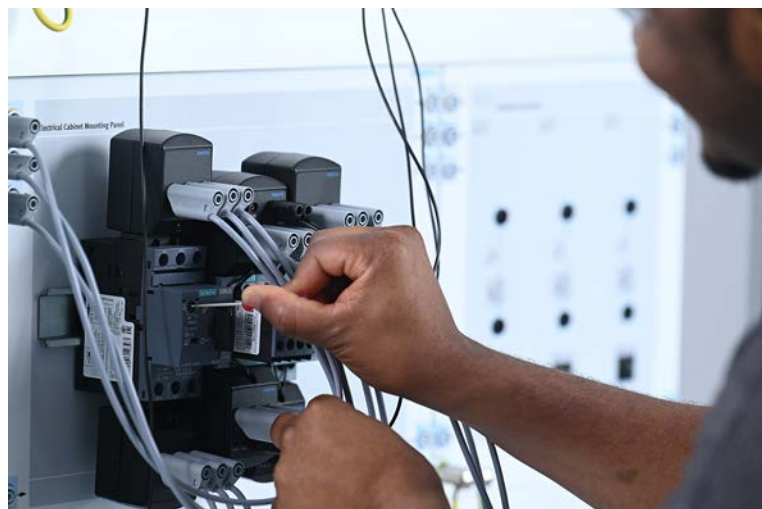

Figure 41: Motor Starter Protector.

The Motor Starter Protector is a thermal-overload circuit-breaker used for manual motor starting and protection. An adjustable rotating button allows the adjustment of the overload current.

**Table 38: Components of the Motor Starter Protector.**

Number	Name	Description
1	Overload current rotating button	Adjustment button for the current rating of the overload protection on the device.
2	Line input terminals	Inputs for each of the three lines (L1, L2, L3) coming from the power supply.
3	On/Off selector switch	Selector switch that turns on or off any motor connected to the Motor Starter Protector. When the device trips, the selector switch is automatically set to Tripped. To reset the device, set the selector switch to Off. The reset only occurs once the thermal overload has sufficiently cooled down. The cause of the tripping should be investigated and cleared before powering the system on again.
4	Line output terminals	Output terminals for each for the three lines (T1, T2, T3) going to the circuit.



**Figure 42: Adjusting the FLA on a motor starter protector.**



**Adjusting the FLA on a motor starter protector.**

<https://lx.festo.com/media/935b1793174742b3bd73604b63096b12>

**Table 39: Main specifications of the Motor Starter Protector.**

Components and parameters	Main specifications
Power rating	3 AC 415 V, 550 W
Adjustable overload release (CLASS 10)	0.7 to 1.0 A
Trip class	CLASS 10
Short-circuit current breaking capacity	100 kA (magnetic)
Connectors	Connections via 4 mm safety sockets
Ingress protection rating	IP20
Electromagnetic compatibility	Group 1, Class A (industrial environment, EN 55011)
Dimensions (H x W x D)	TBD x TBD x TBD mm (TBD x TBD x TBD in)
Weight	TBD kg (TBD lb)
CE and UKCA markings	<ul style="list-style-type: none"> <li>● Low-Voltage Directive</li> <li>● EMC Directive</li> <li>● RoHS Directive</li> </ul>

## Overload Relay (8140798)

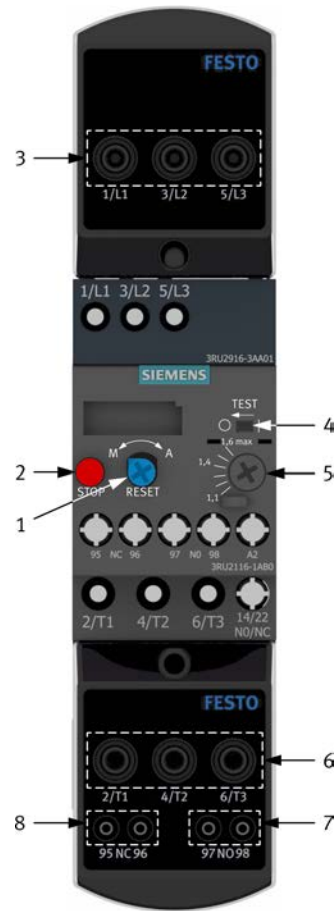

Figure 43: Overload Relay.

The Overload Relay is of the thermal type and can be used to protect a motor. It includes an auxiliary circuit with one normally open contact and one normally closed contact.

Table 40: Components of the Overload Relay.

Number	Name	Description
1	Reset button/selector switch	Selector switch that allows selection between manual and automatic reset. In manual reset, the relay must be reset using the reset button. In Automatic reset, the relay resets once the thermal element has cooled down.
2	Stop button	Button that opens the NC contact.

Number	Name	Description
3	Line input terminals	Inputs for each of the three lines (L1, L2, L3) coming from the power supply.
4	Testing indicator	Indicates a trip condition and allows testing the thermal overload.
5	Motor current setting	Sets the rated motor current.
6	Line output terminals	Output terminals for each for the three lines (T1, T2, T3) going to the circuit.
7	Normally open contact terminals	Terminals of the built-in normally open contact of the relay.
8	Normally closed contact terminals	Terminals of the built-in normally closed contact of the relay.

**Table 41: Main specifications of the Overload Relay.**

Components and parameters	Main specifications
Power rating	3 AC 415 V, 550 W
Auxiliary contacts (2)	24 V DC, 2 A, 1 NO (tripped) + 1 NC (contactor disconnection)
Adjustable overload release (CLASS 10)	1.1 to 1.6 A
Trip class	CLASS 10
Connectors	Connections via 4 mm safety sockets for power and 2 mm sockets for auxiliary contacts
Ingress protection rating	IP20
Electromagnetic compatibility	Group 1, Class A (industrial environment, EN 55011)
Dimensions (H x W x D)	TBD x TBD x TBD mm (TBD x TBD x TBD in)
Weight	TBD kg (TBD lb)

Components and parameters	Main specifications
CE and UKCA markings	<ul style="list-style-type: none"> <li>• Low-Voltage Directive</li> <li>• EMC Directive</li> <li>• RoHS Directive</li> </ul>

## Overload Relay (8140799)

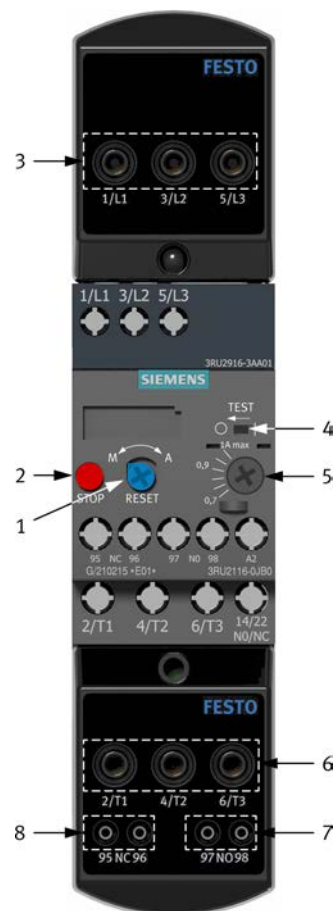

Figure 44: Overload Relay.

The Overload Relay is of the thermal type and can be used to protect a motor. It includes an auxiliary circuit with one normally open contact and one normally closed contact.

**Table 42: Components of the Overload Relay.**

Number	Name	Description
1	Reset button/selector switch	Selector switch that allows selection between manual and automatic reset. In manual reset, the relay must be reset using the reset button. In automatic reset, the relay resets once the thermal element has cooled down.
2	Stop button	Button that opens the NC contact.
3	Line input terminals	Inputs for each of the three lines (L1, L2, L3) coming from the power supply.
4	Testing indicator	Indicates a trip condition and allows testing the thermal overload.
5	Motor current setting	Sets the rated motor current.
6	Line output terminals	Output terminals for each for the three lines (T1, T2, T3) going to the circuit.
7	Normally open contact terminals	Terminals of the built-in normally open contact of the relay.
8	Normally closed contact terminals	Terminals of the built-in normally closed contact of the relay.

**Table 43: Main specifications of the Overload Relay.**

Components and parameters	Main specifications
Power rating	3 AC 415 V, 250 W
Auxiliary contacts (2)	24 V DC, 2 A, 1 NO (tripped) + 1 NC (contactor disconnection)
Adjustable overload release (CLASS 10)	0.7 to 1.0 A
Trip class	CLASS 10
Connectors	Connections via 4 mm safety sockets for power and 2 mm sockets for auxiliary contacts

Components and parameters	Main specifications
Ingress protection rating	IP20
Electromagnetic compatibility	Group 1, Class A (industrial environment, EN 55011)
Dimensions (H x W x D)	TBD x TBD x TBD mm (TBD x TBD x TBD in)
Weight	TBD kg (TBD lb)
CE and UKCA markings	<ul style="list-style-type: none"> <li>• Low-Voltage Directive</li> <li>• EMC Directive</li> <li>• RoHS Directive</li> </ul>

### Time-Delay Relay (8140800)

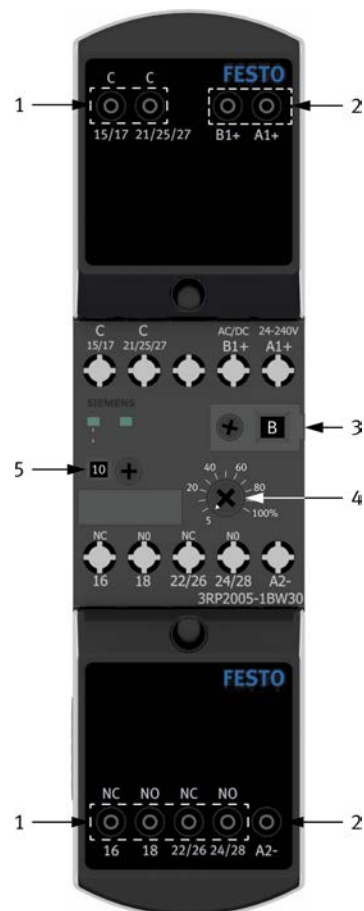

Figure 45: Time-Delay Relay.

**Table 44: Components of the Time-Delay Relay.**

Number	Name	Description
1	Change-over contact terminals	Terminals for the two change-over contacts (SPDT) of the relay.
2	Control circuit terminals	Whether power is connected to B1+ or A1+ depends on the function used. Consult the manufacturer's documentation for more information.
3	Function selector rotating button	Button used to set the relay function.
4	Delay percentage rotating button	Button that sets the percentage of the delay range used as a delay.
5	Delay rotating button	Button that sets the delay range.

**Table 45: Main specifications of the Time-Delay Relay.**

Components and parameters	Main specifications
Functions	<ul style="list-style-type: none"> <li>● ON-delay</li> <li>● OFF-delay with control signal</li> <li>● ON and OFF-delay with control signal</li> <li>● Flashing, starting with interval</li> <li>● Passing make contact</li> <li>● Passing break contact with control signal</li> <li>● Pulse-forming with control signal</li> <li>● Additive ON-delay with control signal</li> </ul>
Time range	0.05 s to 100 h (adjustable)
Output contacts (2)	24 V DC, 1 A, one standard contact and one for instantaneous contact (optional for each function)
Control	24 V DC
Connectors	Connections via 2 mm sockets (24 V DC)

Components and parameters	Main specifications
Ingress protection rating	IP20
Electromagnetic compatibility	Group 1, Class A (industrial environment, EN 55011)
Dimensions (H x W x D)	TBD x TBD x TBD mm (TBD x TBD x TBD in)
Weight	TBD kg (TBD lb)
CE and UKCA markings	<ul style="list-style-type: none"> <li>● Low-Voltage Directive</li> <li>● EMC Directive</li> <li>● RoHS Directive</li> </ul>

### Available functions

The following figure shows the sixteen available functions on the Time-Delay Relay. Consult the manufacturer's documentation for more details.

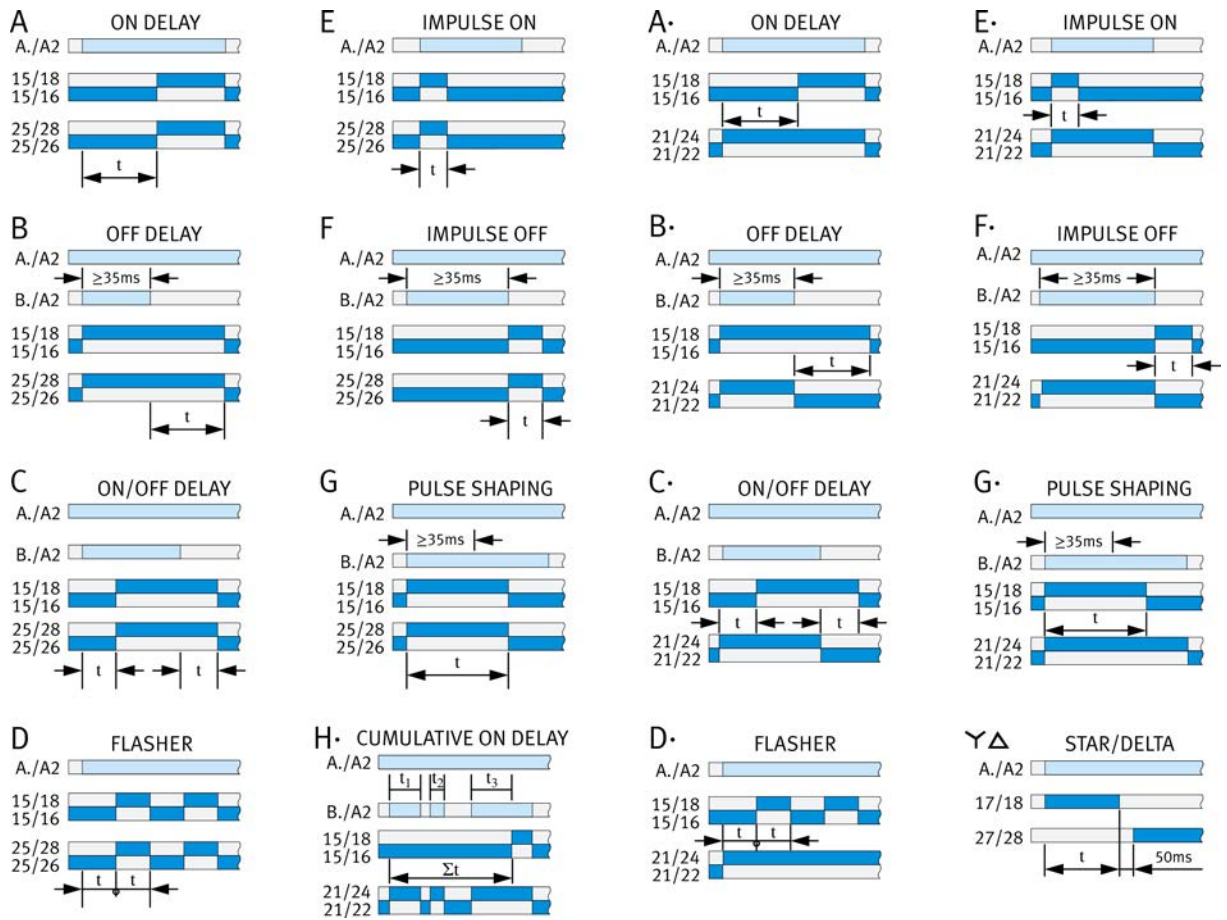

Figure 46: Functions of the Time-Delay Relay.

## Fault Insertion for Troubleshooting

### Using fault-insertion switches

Most modules of the training system allow the insertion of faults to simulate a defective equipment. This can be done using fault switches located behind a panel, as the following figure and videos show.

	<b>⚠ CAUTION</b>
	Always perform a lockout/tagout procedure before inserting or removing faults using fault switches. Never toggle fault switches while power is on.



Figure 47: Fault insertion on a module using switches.



Fault insertion on a module using switches.

<https://lx.festo.com/media/a8040585c20c4723b460a3a0d20a6f19>



Fault insertion on the mobile solution using switches.

<https://lx.festo.com/media/caf0b8f58d9049d8a251fab15435eea6>

## Using fault cards

On some modules, it is also possible to add a fault by replacing the "master" card with a "fault" card, as the following figure and video show.



	 <b>CAUTION</b>
	Always perform a lockout/tagout procedure before changing a fault card on a module. Never change a fault card while power is on.



Figure 48: Changing the fault card on a module.



Changing the fault card on a module.

<https://lx.festo.com/media/e5e82c9eb257434c9be8788d3224894a>



## Equipment Maintenance

The equipment is designed to ensure user safety, reliability, and effective learning outcomes. To maintain safety and performance, it is important to keep the equipment in good condition.

The learning system needs regular maintenance. Students will perform some tasks as part of their training, while qualified personnel must handle other periodic maintenance.

Since trainees may not yet detect issues, a technician or instructor should inspect the system before and after each use.

Replace defective or missing components immediately. Contact our service department for replacement parts and instructions.

 <b>CAUTION</b>	
	<ul style="list-style-type: none"><li>• Instructors and laboratory personnel must communicate these directions and guidelines to students, as they are essential for maintaining the equipment's safety and functionality.</li><li>• Do not operate the equipment with missing or damaged parts.</li></ul>

### General maintenance

The equipment does not require any particular maintenance. However, it is very important to perform a visual inspection of the equipment before each laboratory exercise. If a piece of equipment appears damaged or shows wear, it must be replaced to ensure user safety and prevent further damage to the equipment.

There are no user serviceable parts inside the equipment, other than certain parts that may need to be replaced, such as fuses, button cells, batteries, etc. Opening or removing the equipment housing to replace parts may expose you to dangerous voltages. Do not try to open the equipment housing to replace parts. Have a qualified technician replace parts in the equipment.

## Consumables and replacement parts

It is possible to replace certain pieces of equipment that are consumable or that have been damaged. Use only Festo Didactic parts and accessories to ensure compatibility and sustainability of the equipment. Most parts and accessories used for the Industrial Wiring Learning System are part of component kits and come with a packing document listing all included parts and their corresponding part numbers. We highly recommend keeping these lists for reference. Should you need replacement parts or kits, contact your Festo Didactic representative.

## Equipment disposal

Do not discard the equipment with normal waste: it contains electrical and electronic components. A specialist must dismantle the product. Each component must be recycled or disposed of according to your local legislation.

It is the owner's responsibility to make provisions for the equipment recycling and safe disposal.

Waste from Electrical and Electronic Equipment (WEEE) directive:

- In accordance with European regulations, used electrical and electronics devices cannot be disposed of in unsorted municipal waste. The symbol of the waste bin on wheels indicates the necessity for separate collection. For environmental protection, make sure the equipment is disposed of in the waste sorting processes designed for this purpose. DIRECTIVE 2012/19/EU of the EUROPEAN PARLIAMENT AND OF the COUNCIL of 4 July 2012 on waste electrical and electronic equipment (WEEE).



The presence of this symbol on the equipment indicates the necessity of separate collection.

## Cleaning

To clean the front panel(s) and housing(s) of the equipment, use a soft cloth and a mild solution of detergent and water. It is important not to apply the solution directly onto the surface of the equipment. Instead, apply the solution onto the soft cloth.

### **NOTICE**

Unless specifically stated otherwise, do not use abrasive substances or solvents to clean any part of the equipment.

## Indications of conformity

### Directives and declarations of conformity

The directives applicable to each piece of equipment in the learning system are specified in the corresponding Equipment Description section.

You can download declarations of conformity for all available equipment using the following link:

1. Enter your equipment name in the search field.
2. Click the "Didactic Products" tab.
3. Select your equipment from the search results.
4. Open the "Downloads" tab.
5. Go to the "Certificates" section.
6. Download the required documents.



**Festo website.**

<https://www.festo.com>

### Electromagnetic compatibility (EMC)

The following table outlines international electromagnetic compatibility (EMC) compliance requirements, specifying applicable standards, equipment classifications, and usage limitations.

**Table 46: Electromagnetic compatibility (EMC) compliance.**

<p>International</p>	<p>EN IEC 61326-1: Basic Electromagnetic Environment            CISPR 11: Group 1 or 2 (see the Equipment Description section for precision on each piece of equipment), Class A</p> <ul style="list-style-type: none"> <li>● Group 1: Equipment covered by this standard that is not classified as Group 2.</li> </ul> <p>Group 2: Industrial, scientific, and medical radio-frequency (ISM RF) equipment that intentionally generates or uses radio-frequency energy (9 kHz to 400 GHz), locally applied via electromagnetic radiation, inductive or capacitive coupling, for purposes such as material treatment, inspection, analysis, or energy transfer.</p> <ul style="list-style-type: none"> <li>● Class A: Equipment is suitable for use in all establishments other than domestic and those directly connected to a low-voltage power supply network that supplies buildings used for domestic purposes. There may be potential difficulties in ensuring electromagnetic compatibility in other environments due to conducted and radiated disturbances.</li> <li>● Caution: This equipment is not intended for use in residential environments and may not provide adequate protection to radio reception in such environments.</li> </ul>
----------------------	--



