

Diese Zeichnung ist Eigentum der Festo Didactic SE
This drawing is the property of Festo Didactic SE



Schaltungsunterlagen Circuit diagrams

Bezeichnung:
designation: SkillsConveyor NEMA

Kunde:
Customer:

Anlagenkennzeichen
Plant identifier G1 SkillsConveyor

Variante
variant Skills Bandsteuerung

Bemerkung:
remark: NEMA-Version des Schaltplans
NEMA version of the schematic

letzte Änderung:
last Modification: 2022-12-19

Druckdatum:
Print date: 2022-12-19

Pfad:
Path: \\festo.net\DFS01\INT\Data\EPLAN\DATA_xx\CA\Projects\Labvolt\SkillsConveyor_NEMA.elk

&EAB/2>>

Date	2022-12-12	Festo Didactic SE Rechbergstraße 3 D-73770 Denkendorf		Titel- / Deckblatt Title page/cover sheet	Part number				
Ed. by.	ca0fgvn				PSP / DPJ	VN	= G1	SkillsConveyor	Page 1
Drw.No.							+		of 14
Creat.	ca0fgvn	N:	F:FDMD11DE	Version:2.9.4	\\festo.net\DFS01\INT\Data\EPLAN\DATA_xx\CA\Projects\Labvolt\SkillsConveyor_NEMA.elk				

Diese Zeichnung ist Eigentum der Festo Didactic SE. This drawing is the property of Festo Didactic SE.

&EAB

Inhaltsverzeichnis Table of contents

<&EAA/1

3>>

Date	2022-12-09	Festo Didactic SE Rechbergstraße 3 D-73770 Denkendorf		Übersicht overview	Part number			
Ed. by.	ca0fgvn				PSP / DPJ	VN	= G1	SkillsConveyor
Creat.	ca0fgvn						+	
Drw.No.		N:	F:	Version: 2.9.4	\\festo.net\DFS01\INTData\EPLANDATA_xi\CAI\Projects\Labvolt\SkillsConveyor_NEMA.elk			Page 2 of 14

Diese Zeichnung ist Eigentum der Festo Didactic SE. This drawing is the property of Festo Didactic SE.

+GL1

SkillsConveyor

Date	2022-12-09
Ed. by.	ca0fgvn
Creat.	ca0fgvn
Drw.No.	

Festo Didactic SE Rechbergstraße 3 D-73770 Denkendorf	
N:	
F:	
Version:	2.9.4
\\festo.net\DFS01\INTData\EPLANDATA_xi\CAI\Projects\Labvolt\SkillsConveyor_NEMA.elk	



Übersicht overview

Part number	
PSP / DPJ	VN

= G1	SkillsConveyor
+ GL1	SkillsConveyor

Diese Zeichnung ist Eigentum der Festo Didactic SE. This drawing is the property of Festo Didactic SE.

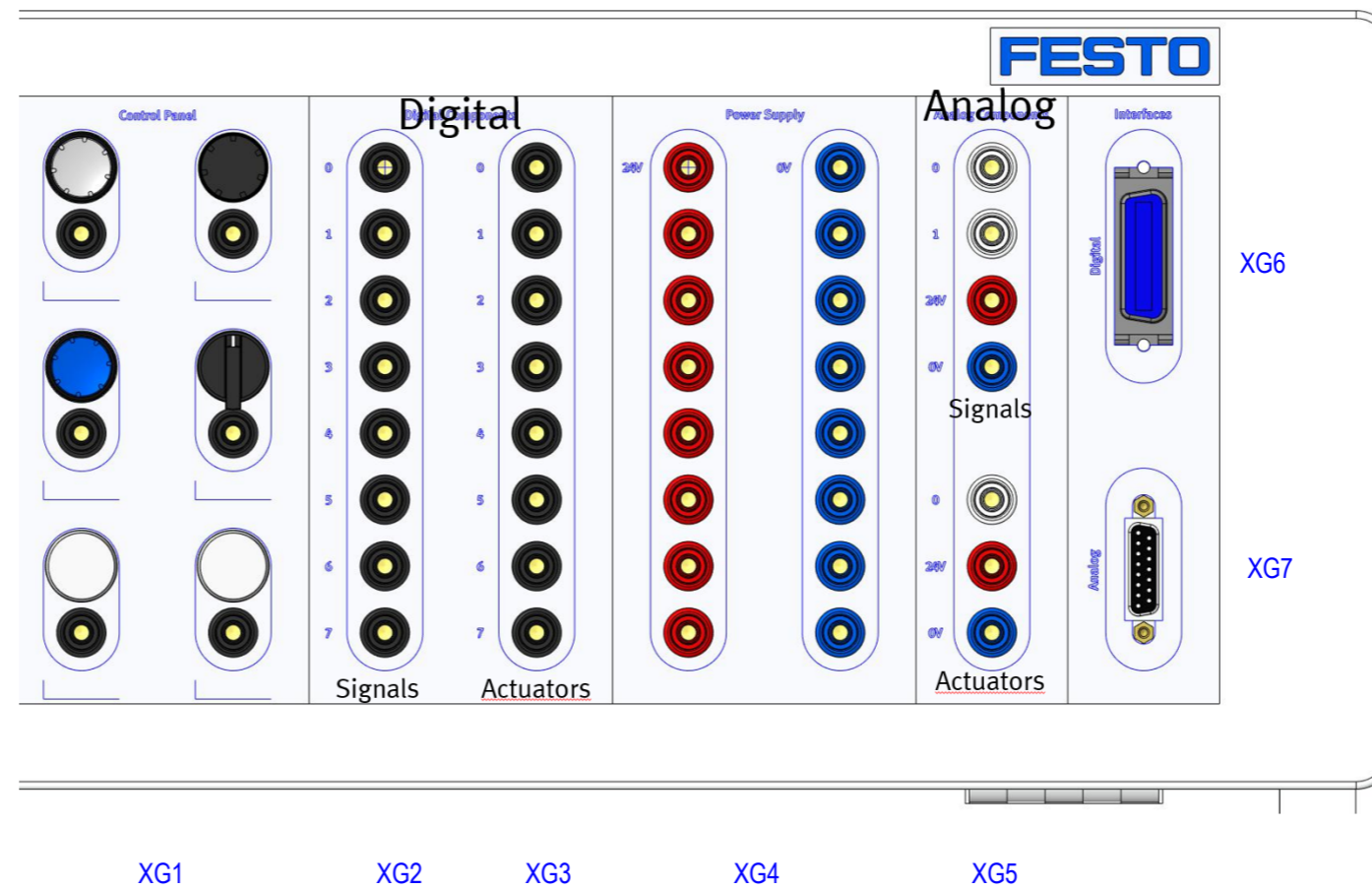

This drawing is the property of Festo Didactic SE

XG6 Digital

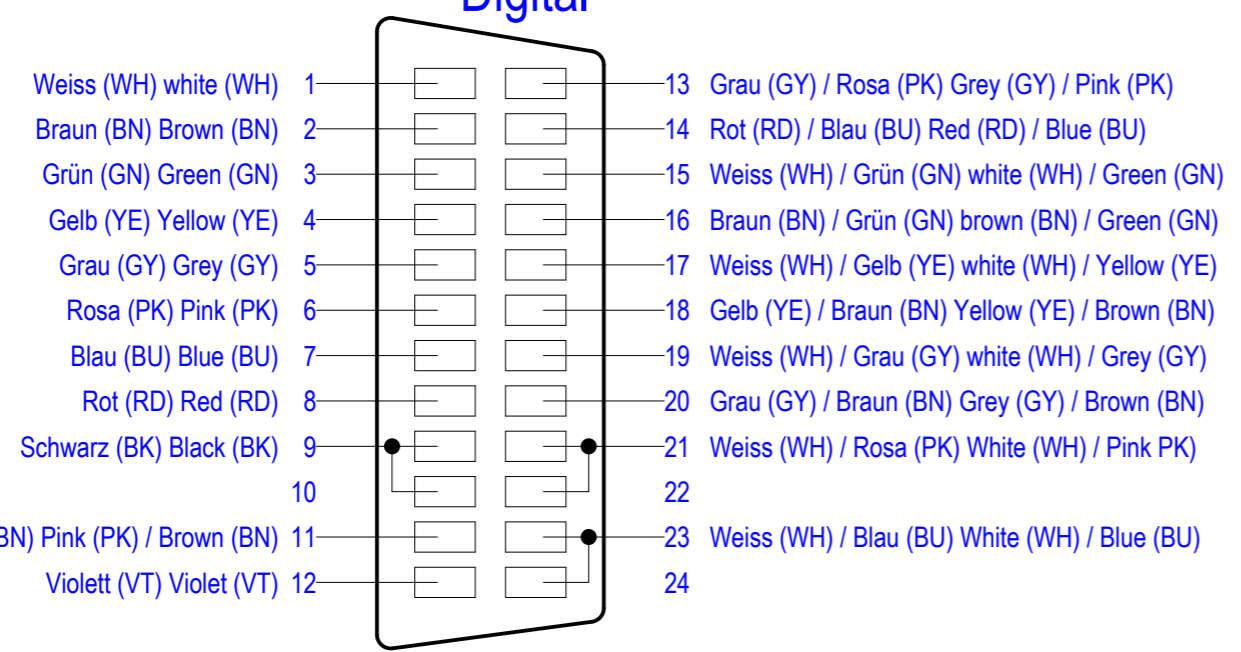

XG7 Analog

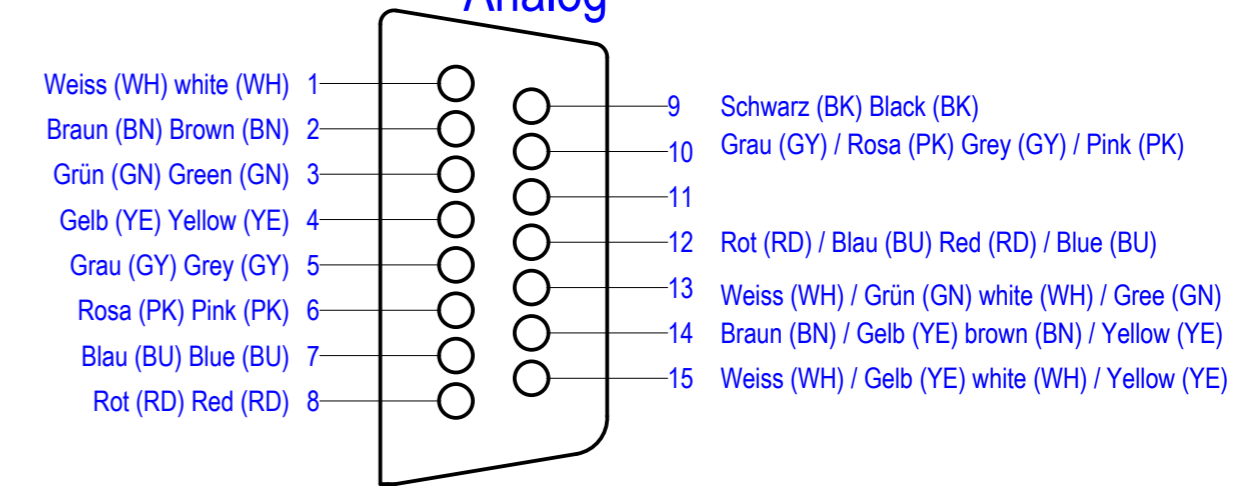

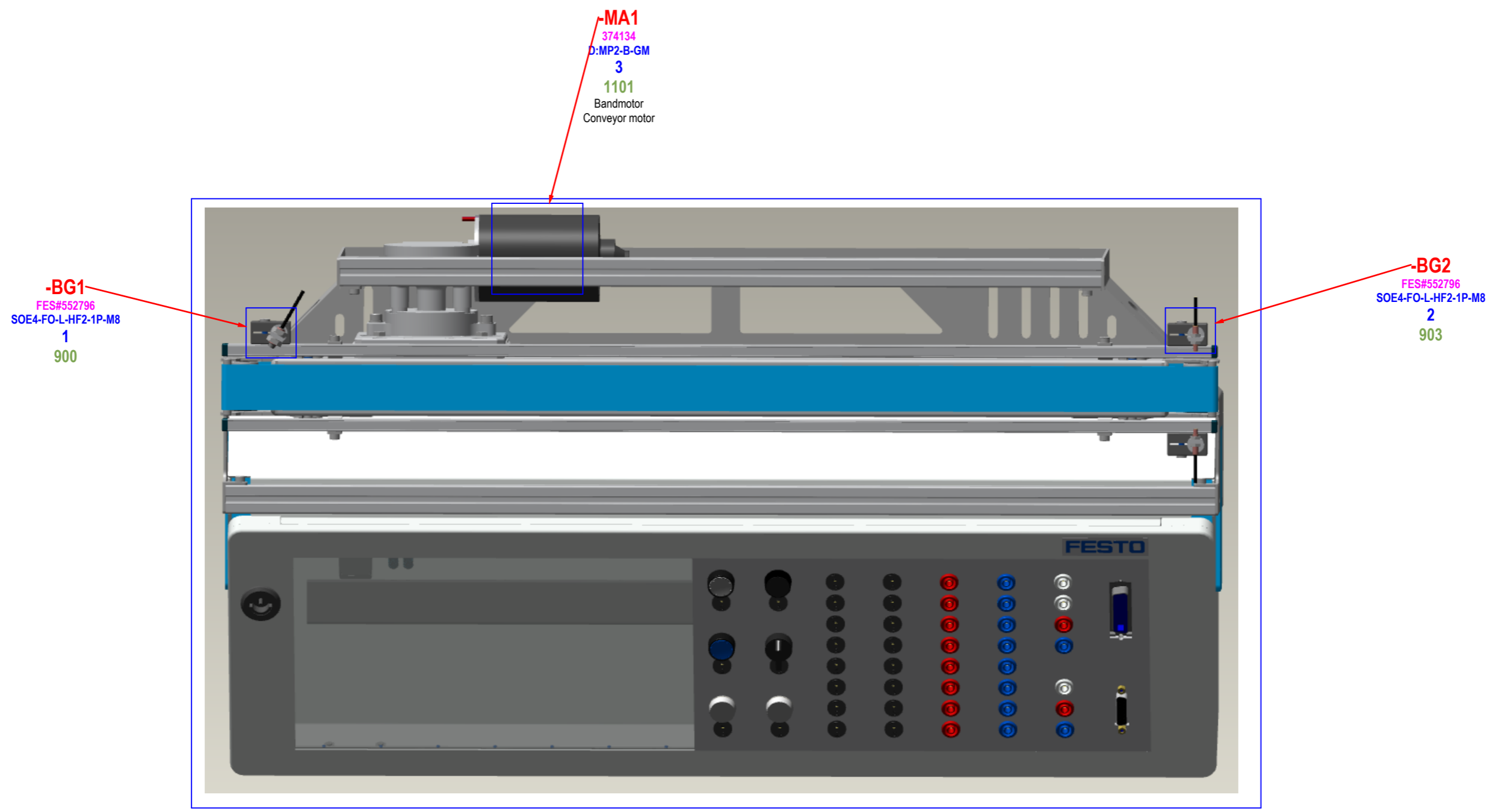

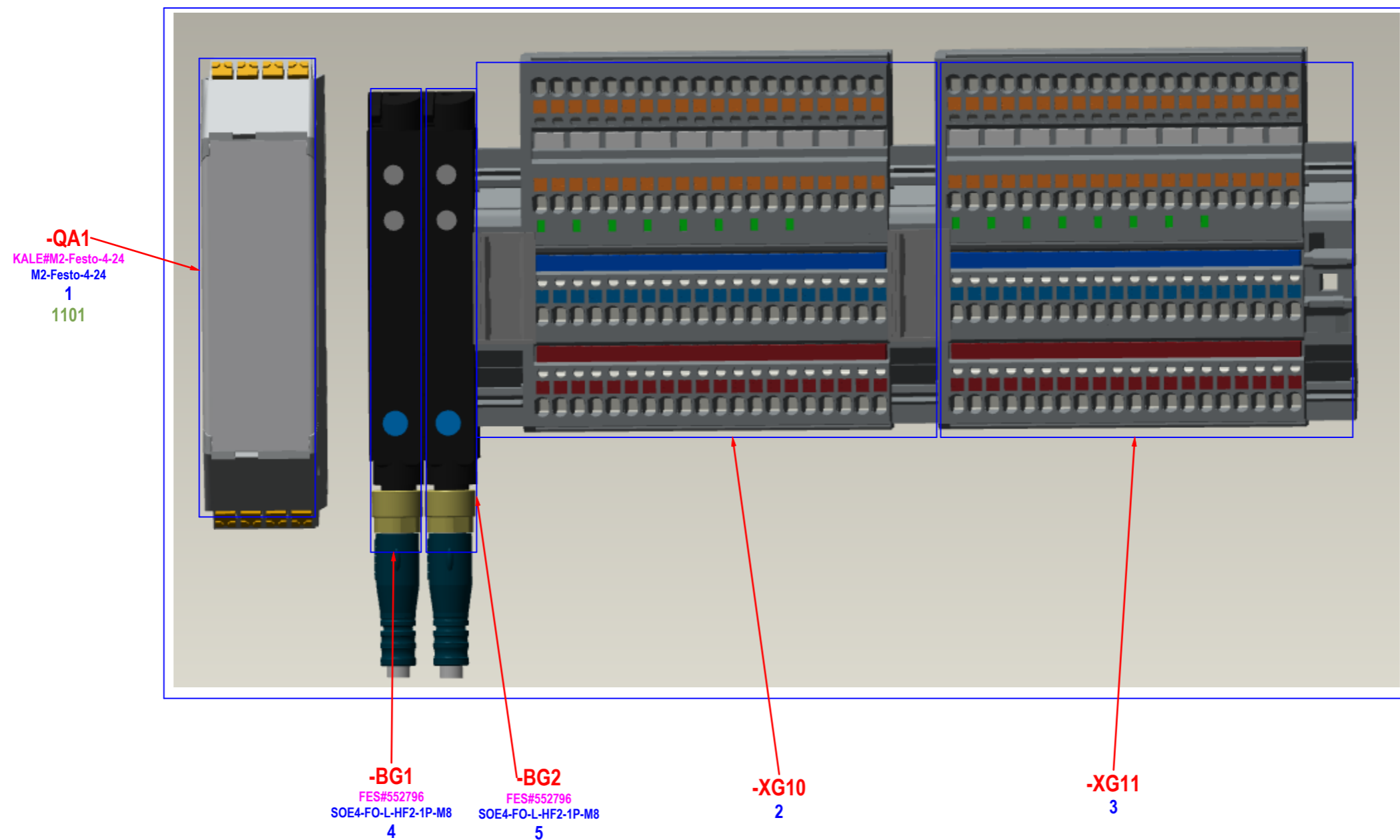

Date	2022-12-19
Ed. by.	ca0fgvn
Creat.	ca0fgvn
Drw.No.	

Festo Didactic SE
 Rechbergstraße 3
 D-73770 Denkendorf



Schaltschrank Control cabinet

Part number	
PSP / DPJ	VN

= G1	SkillsConveyor
+ GL1	SkillsConveyor

Diese Zeichnung ist Eigentum der Festo Didactic SE. This drawing is the property of Festo Didactic SE.

900
901
902
903
904
905
906
907
908
909
910
911
912
913
914
915
916
917

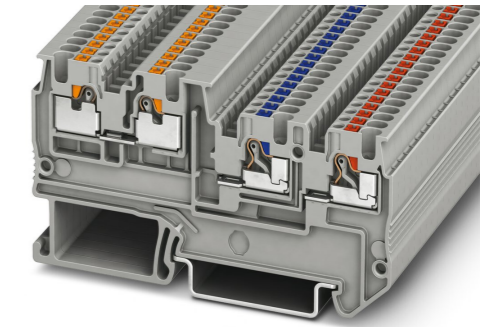
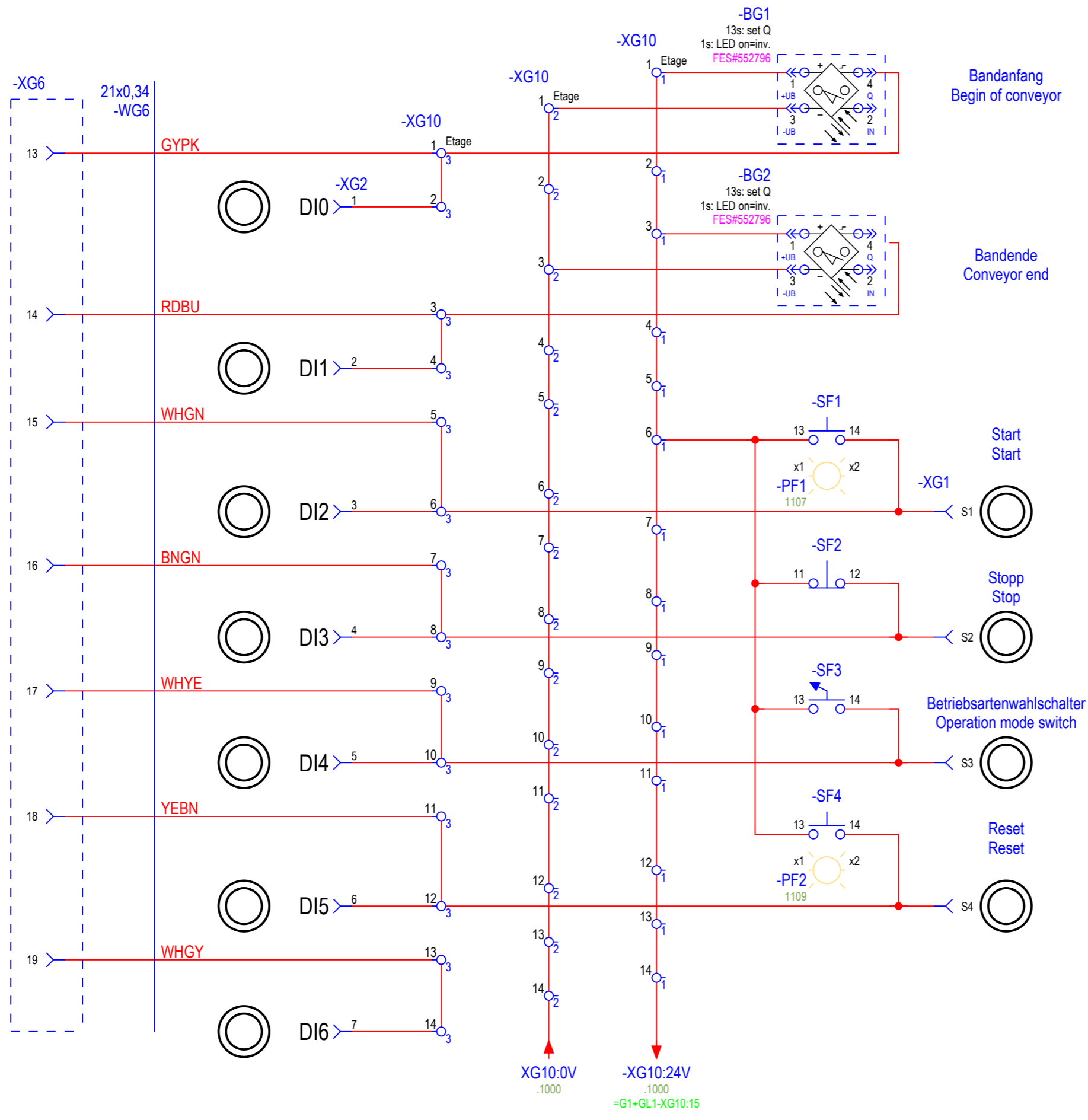

Etage 3 Level 3
Etage 2 Level 2
Etage 1 Level 1

Date	2022-12-19	FESTO Eingänge inputs Festo Didactic SE Rechbergstraße 3 D-73770 Denkendorf	Part number		
Ed. by	ca0fgvn		PSP / DPJ	VN	
Drw.No.	ca0fgvn		= G1	SkillsConveyor	Page 9
			+ GL1	SkillsConveyor	of 14

Diese Zeichnung ist Eigentum der Festo Didactic SE. This drawing is the property of Festo Didactic SE.

1000
1001
1002
1003
1004
1005
1006
1007
1008
1009
1010
1011
1012
1013
1014
1015
1016
1017

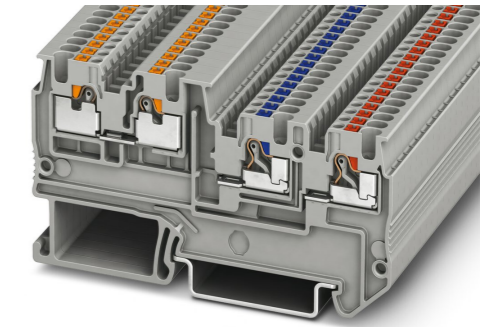
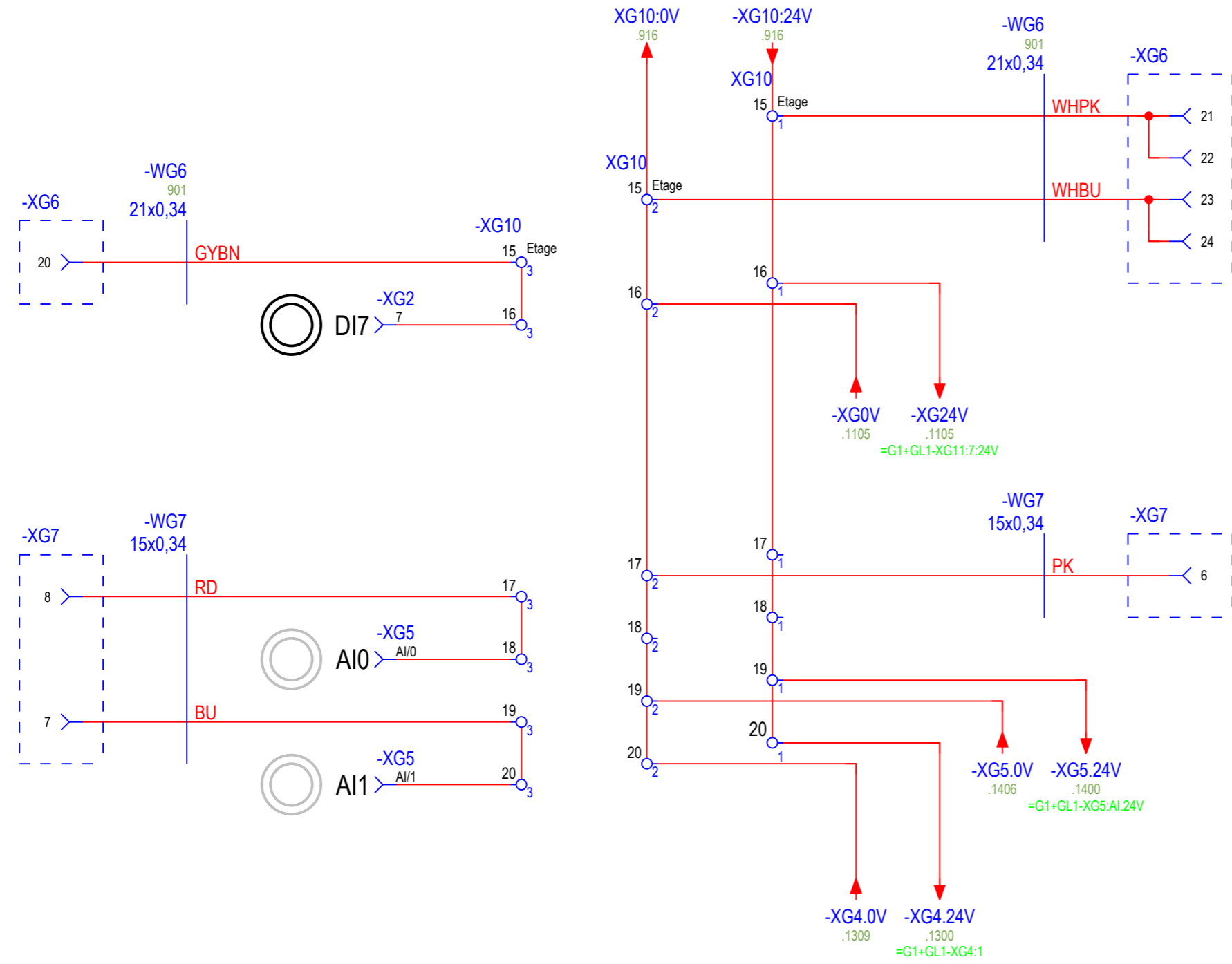

Etage 3 Level 3 Etage 2 Level 2 Etage 1 Level 1



Date	2022-12-19
Ed. by.	ca0fgvn
Creat.	ca0fgvn
Drw.No.	

Festo Didactic SE
Rechbergstraße 3
D-73770 Denkendorf



Eingänge inputs

Part number	
PSP / DPJ	VN

= G1	SkillsConveyor	Page 10
+ GL1	SkillsConveyor	of 14

Diese Zeichnung ist Eigentum der Festo Didactic SE. This drawing is the property of Festo Didactic SE.

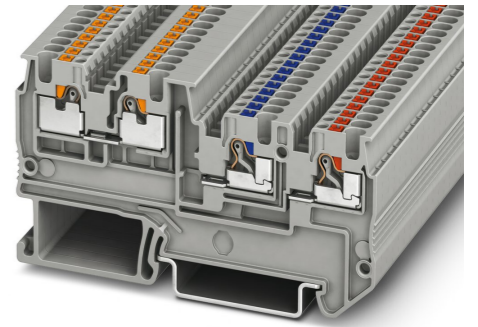
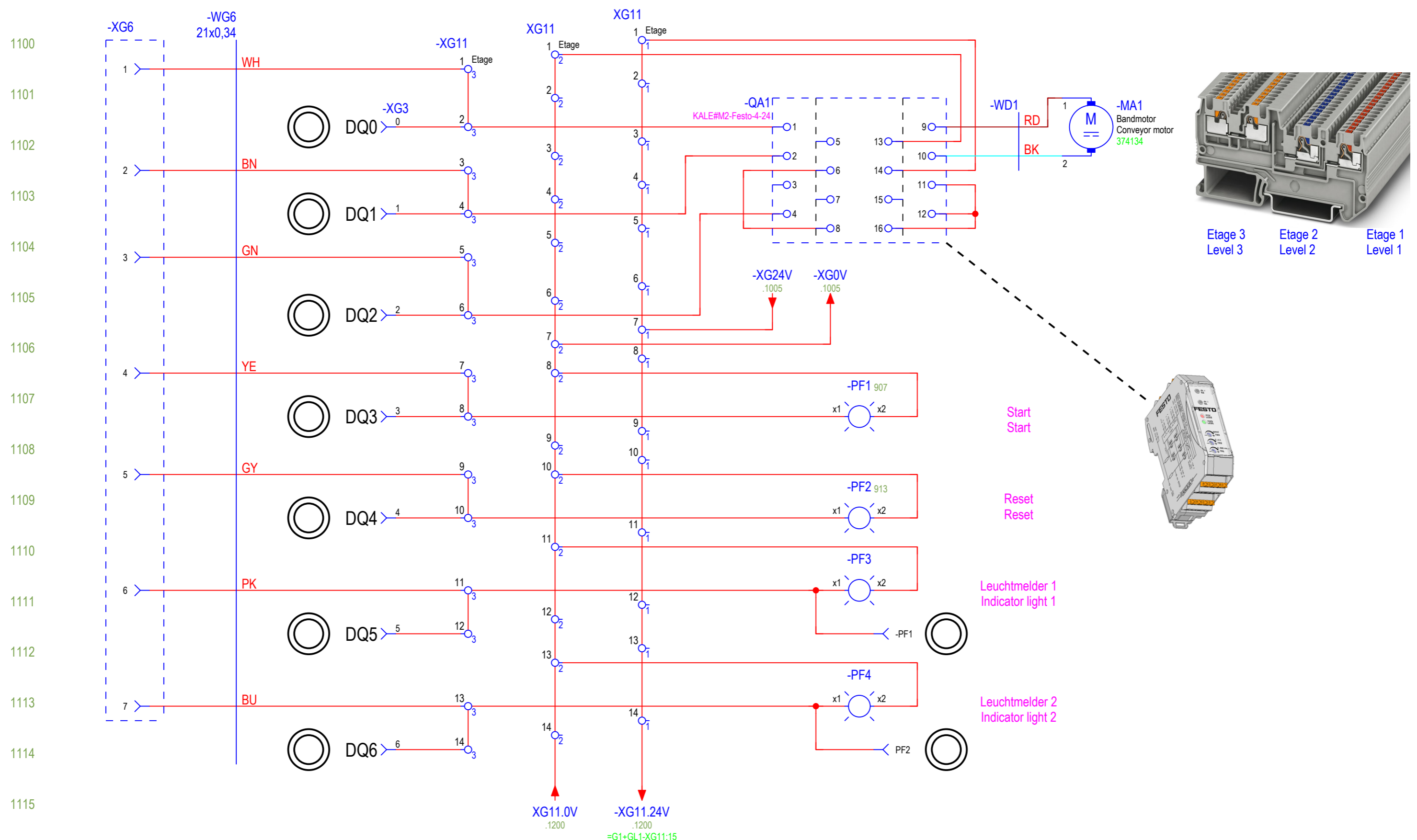

Etage 3 Level 3
Etage 2 Level 2
Etage 1 Level 1

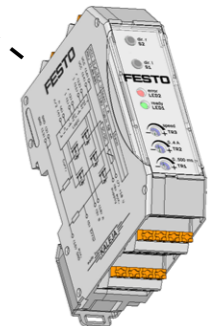

Start
Start

Reset
Reset

Leuchtmelder 1
Indicator light 1

Leuchtmelder 2
Indicator light 2

Diese Zeichnung ist Eigentum der Festo Didactic SE. This drawing is the property of Festo Didactic SE.

1200
1201
1202
1203
1204
1205
1206
1207
1208
1209
1210
1211
1212
1213
1214
1215
1216
1217

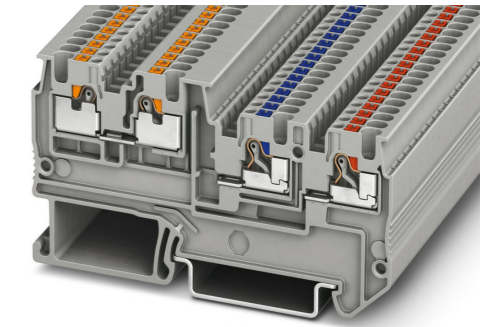
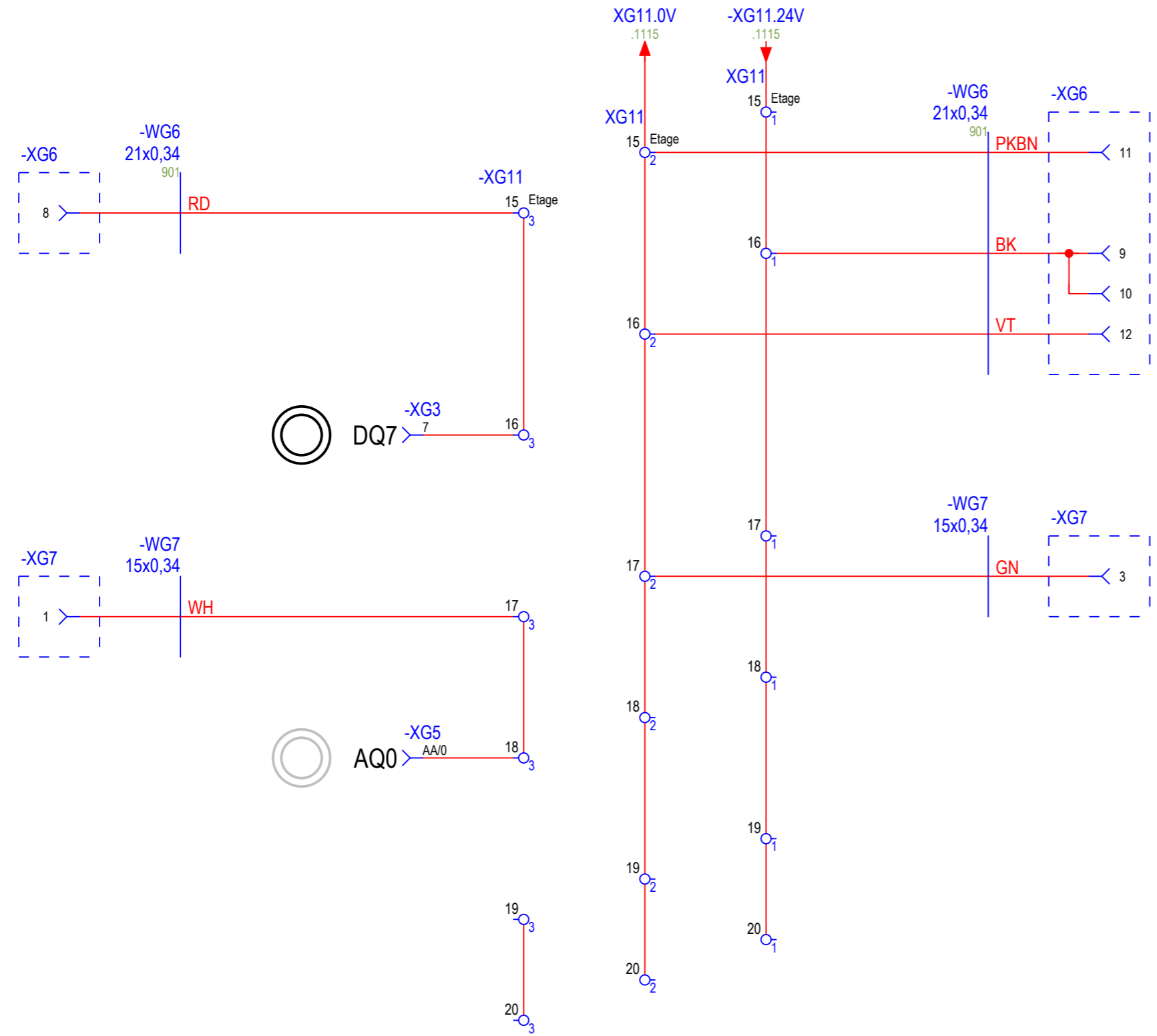

Etage 3 Level 3 Etage 2 Level 2 Etage 1 Level 1

Date	2022-12-15	FESTO Festo Didactic SE Rechbergstraße 3 D-73770 Denkendorf
Ed. by.	ca0fgvn	
Creat.	ca0fgvn	
Drw.No.		

Ausgänge outputs		Part number
N:	F:	PSP / DPJ VN
Version: 2.9.4	\\festo.net\DFS01\INT\Data\EPLANDATA_xi\CAI\Projects\Labvolt\SkillsConveyor_NEMA.elk	

= G1	SkillsConveyor	Page 12
+ GL1	SkillsConveyor	of 14

Diese Zeichnung ist Eigentum der Festo Didactic SE. This drawing is the property of Festo Didactic SE.

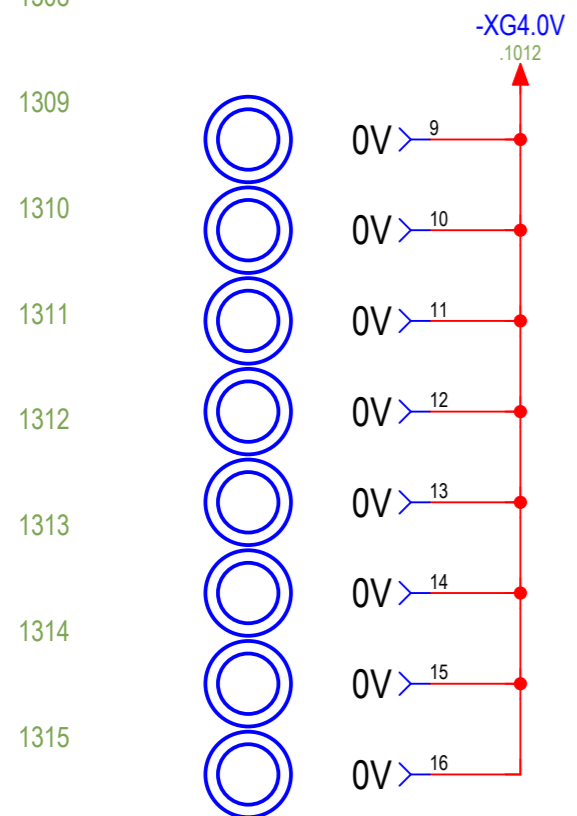
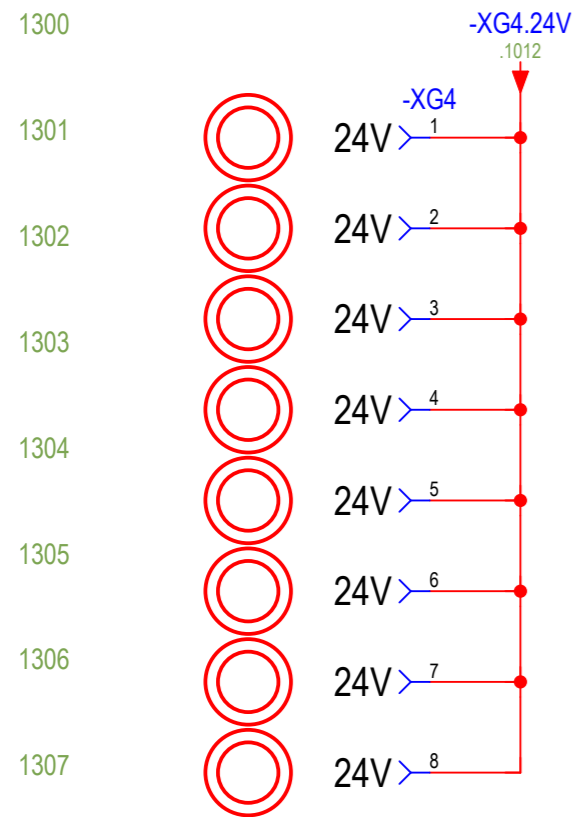

Date	2022-12-15	Festo Didactic SE Rechbergstraße 3 D-73770 Denkendorf		Spannungsversorgung Power supply		Part number			
Ed. by.	ca0fgvn			PSP / DPJ	VN	= G1	SkillsConveyor	Page	13
Creat.	ca0fgvn					+ GL1	SkillsConveyor	of	14
Drw.No.		N:	F:	Version: 2.9.4	\\festo.net\DFS01\INT\Data\EPLAN\DATA_xi\CAI\Projects\Labvolt\SkillsConveyor_NEMA.elk				

Diese Zeichnung ist Eigentum der Festo Didactic SE. This drawing is the property of Festo Didactic SE.

1400
1401
1402
1403
1404
1405
1406
1407
1408
1409
1410
1411
1412
1413
1414
1415
1416
1417

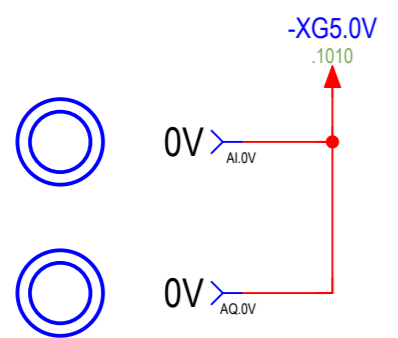
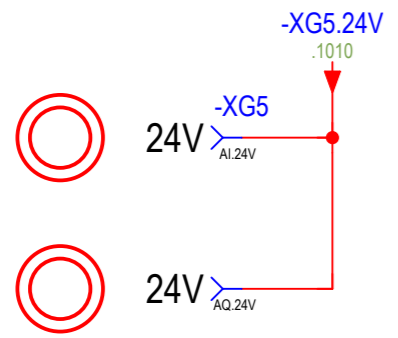

<<3

>>

Date	2022-12-15	Festo Didactic SE Rechbergstraße 3 D-73770 Denkendorf		Spannungsversorgung Power supply	Part number				
Ed. by.	ca0fgvn				PSP / DPJ	VN	= G1	SkillsConveyor	Page 14
Creat.	ca0fgvn						+ GL1	SkillsConveyor	of 14
Drw.No.		N:	F:	Version: 2.9.4	\\festo.net\DFS01\INT\DATA\EPLANDATA_xi\CAI\Projects\Labvolt\SkillsConveyor_NEMA.elk				