

Valve terminal VTSA/VTSA-F, NPT

FESTO

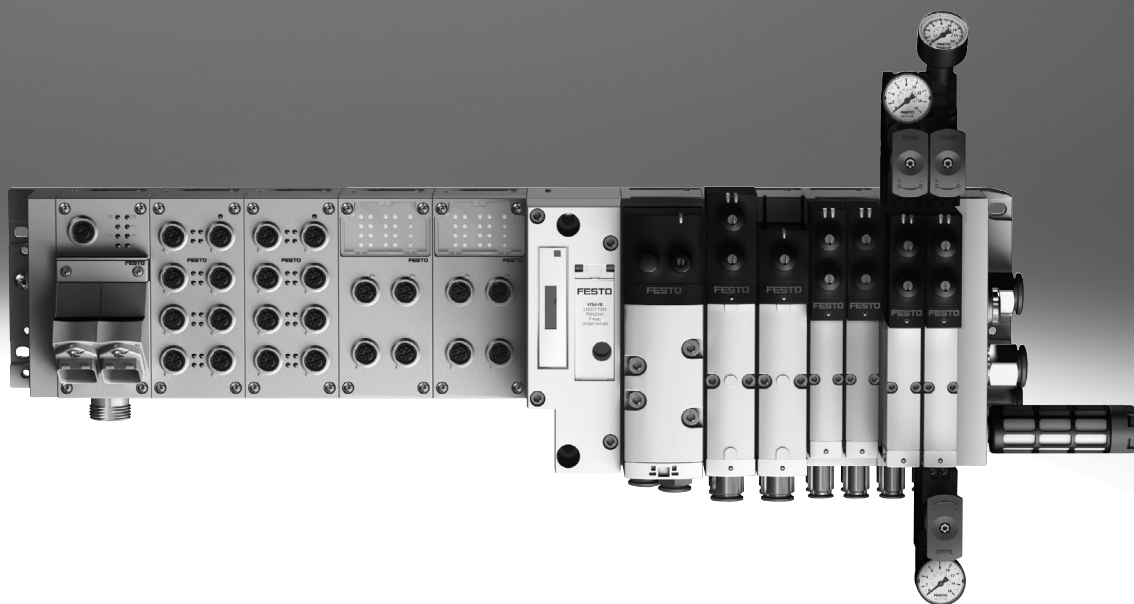

Key features

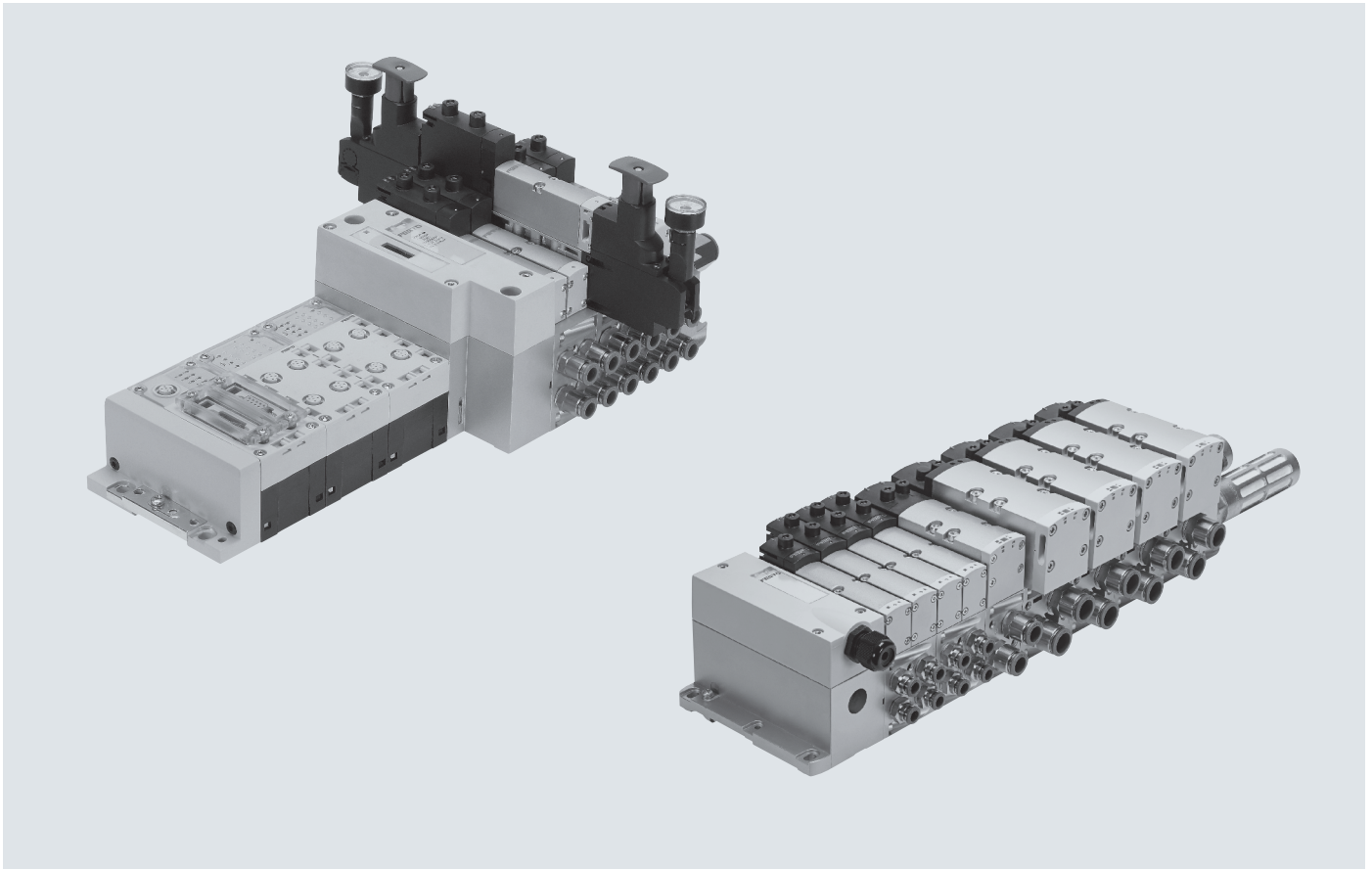

Innovative

- High-performance valves in a sturdy metal housing
- Five valve sizes on one valve terminal
- Standardised from the multi-pin plug to the fieldbus connection and control block
- Dream team: fieldbus valve terminal suitable for electrical peripherals CPX. This means:
 - Forward-looking internal communication system for actuating the valves and CPX modules
 - Four valve sizes on one valve terminal without adapters
- Valve functions for integration in control architectures of higher categories to EN ISO 13849-1

Versatile

- Modular system offering a range of configuration options
- Up to 32 solenoid coils
- Conversions and extensions are possible at any time
- Possible to integrate innovative function modules
- Flexible air supply and variable pressure zones
- Reverse operation
- High pressure range
- $-0.9 \dots 10$ bar, flow rate range $550 \dots 4000$ l/min
- Wide range of valve functions
- Valves: 24 V DC

Reliable

- Sturdy and durable metal components
 - Valves
 - Manifold sub-bases
 - Seals
- Fast troubleshooting with LEDs on the valves and diagnostics via fieldbus
- Reliable servicing thanks to valves that can be replaced quickly and easily
- Manual override, either non-detenting, non-detenting/detenting or concealed
- Durable thanks to tried-and-tested piston spool valves
- Large and durable labelling system
- 100% duty cycle

Easy to install

- Ready-to-install and tested unit
- Reduced selection, ordering, installation and commissioning costs
- Solid wall mounting or DIN rail mounting
- Manifold sub-bases can be extended using four screws, sturdy duct separation on metal support

Key features

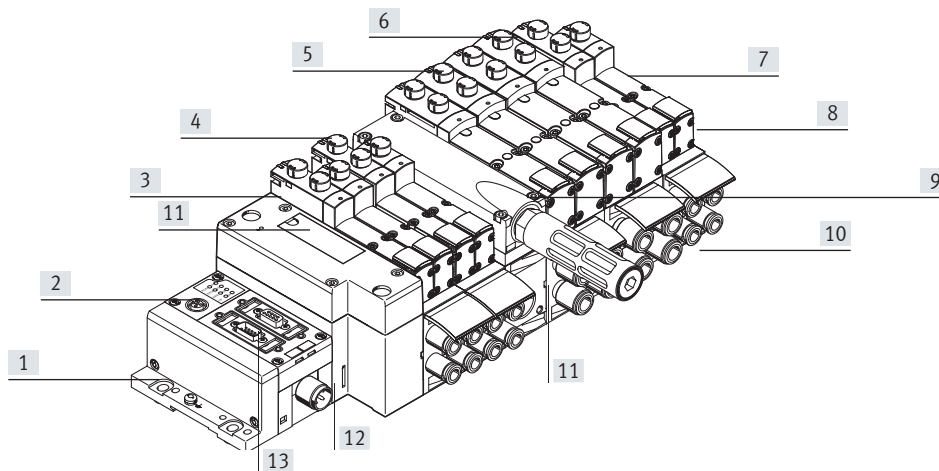

- | | | | |
|---|--|--|---|
| <p>[1] Quick to mount: directly using screws or DIN rail</p> <p>[2] CPX diagnostic interface for handheld devices (channel-oriented diagnostics down to the individual valve)</p> <p>[3] Pneumatic interface to CPX</p> <p>[4] Width 18 mm, 26 mm, 42 mm and 52 mm can be combined on a single valve terminal without adapter</p> | <p>[5] Reduced downtimes: on-site LED diagnostics</p> <p>[6] Safe operation: manual override non-detenting, non-detenting/ detenting or concealed</p> <p>[7] Versatile: 32 valve positions/32 solenoid coils
One valve series for a wide range of flow rates</p> <p>[8] Comprehensive range of valve functions</p> | <p>[9] Modular: air supply plate facilitates the creation of multiple pressure zones as well as numerous additional exhaust and supply ports</p> <p>[10] Practical: large connections, flow-optimised ducts, sturdy metal threads or pre-assembled push-in connections for compressed air tubing with standardised O.D.</p> <p>[11] Convenient: large inscription labels</p> | <p>[12] Reliable: valves, outputs and logic voltage can be switched off separately</p> <p>[13] Simple electrical connections</p> <ul style="list-style-type: none"> – Fieldbus interface via CPX – Multi-pin plug connection with pre-assembled cable or terminal strip (Cage Clamp®) – Control block via CPX – AS-Interface – Individual connection – IO-Link® – AP interface |
|---|--|--|---|

Equipment options

Valve functions

- | | | | |
|--|--|---|---|
| <ul style="list-style-type: none"> • 2x 2/2-way valve, single solenoid, pneumatic spring, normally closed • 2x 3/2-way valve, single solenoid <ul style="list-style-type: none"> – Normally open – Normally open, reversible – Normally closed – Normally closed, reversible • 2x 3/2-way valve, single solenoid <ul style="list-style-type: none"> – 1x normally open, 1x normally closed – 1x normally open, 1x normally closed, reversible | <ul style="list-style-type: none"> • 5/2-way solenoid valve <ul style="list-style-type: none"> – Single solenoid, pneumatic spring/mechanical spring – Double solenoid – Double solenoid with dominant signal • 5/2-way valves for special functions, single solenoid <ul style="list-style-type: none"> – Mechanical spring – Switching position sensing via inductive sensors with PNP or NPN output – Protection against unexpected start-up to EN 1037 – Reversing • 5/3-way solenoid valve <ul style="list-style-type: none"> – Mid-position pressurised – Mid-position closed – mid-position exhausted | <ul style="list-style-type: none"> • 5/3-way solenoid valve for special functions <ul style="list-style-type: none"> – Switching position 14 is retained (switching position 14 is retained in the event of an emergency off application/power failure), there is no spring return to switching position 12. – Only for valve terminal (plug-in) – Mid-position exhausted or mid-position 1→2, 4→5 – Switching position 14 is retained – Pneumatic spring return | <ul style="list-style-type: none"> • 5/3-way solenoid valve for special functions <ul style="list-style-type: none"> – Switching position 12 is retained (switching position 12 is retained in the event of an emergency off application/power failure), there is no spring return to switching position 14. – Only for valve terminal (plug-in) – Mid-position exhausted or mid-position 1→4, 2→3 – Switching position 12 is retained – Pneumatic spring return • Soft-start valve for slow and safe pressure build-up <ul style="list-style-type: none"> – High degree of safety – Sensing function provides feedback on switching operation |
|--|--|---|---|

Key features

Special features

Individual valve on individual sub-base up to width 52 mm

Valve terminal with fieldbus connection and electrical peripherals

<p>Plug-in</p> <ul style="list-style-type: none"> Electrical connection via standardised 4-pin M12 plug or via 4-pin spring-loaded terminal for configuration by the user Available with internal/external pilot air supply 	<p>Square plug or plug-in, with integrated switching position sensing</p> <ul style="list-style-type: none"> Electrical connection to DIN EN 175301-803 type C (square plug) or For configuration by the user via 4-pin spring-loaded terminal or Cable with open end 	<p>CPX terminal</p> <ul style="list-style-type: none"> Max. 32 valve positions/max. 32 solenoid coils Any compressed air supply Any number of pressure zones 	
<p>Valve terminal with individual connection</p> <ul style="list-style-type: none"> Max. 20 valve positions/max. 20 solenoid coils Any compressed air supply Any number of pressure zones 	<p>Valve terminal with multi-pin plug connection:</p> <ul style="list-style-type: none"> Max. 32 valve positions/max. 32 solenoid coils Parallel, modular valve links Any compressed air supply Any number of pressure zones 	<p>AS-Interface</p> <ul style="list-style-type: none"> 1 to 8 valve positions/ max. 8 solenoid coils Soft-start valve for slow and safe pressure build-up 	<p>Combinable</p> <ul style="list-style-type: none"> Width 18 mm: flow rate of VTSA up to 550 l/min, VTSA-F up to 700 l/min Width 26 mm: flow rate of VTSA up to 1100 l/min, VTSA-F up to 1350 l/min Width 42 mm: flow rate of VTSA up to 1300 l/min, VTSA-F up to 1860 l/min Width 52 mm: valve flow rate up to 2900 l/min Width 18 mm, 26 mm, 42 mm and 52 mm can be combined on a single valve terminal
<p>I-Port</p> <ul style="list-style-type: none"> Max. 16 valve positions/max. 32 solenoid coils Connection to an I-Port master Direct mounting of a bus node 	<p>IO-Link®</p> <ul style="list-style-type: none"> Max. 16 valve positions/max. 32 solenoid coils Connection to an IO-Link master 	<p>AP interface</p> <ul style="list-style-type: none"> Max. 12 valve positions/max. 24 solenoid coils Connection to an AP bus master 	<p> Note</p> <ul style="list-style-type: none"> Valve terminal VTSA complies with ISO 15407-2 in width 18 and 26 mm and with ISO 5599-2 in width 42 and 52 mm

Key features

Valve terminal configurator

→ Internet: www.festo.com

A valve terminal configurator is available to help you select a suitable VTSA/VTSA-F valve terminal, making it much easier to order the right product.

The valve terminals are assembled according to your order specification and are individually checked. This reduces assembly and installation time to a minimum.

Order a valve terminal VTSA using the order code:

Ordering system for VTSA
→ Internet: vtsa

Ordering system for CPX
→ Internet: cpx

Order a valve terminal VTSA-F using the order code:

Ordering system for VTSA-F
→ Internet: vtsa-f

Ordering system for CPX
→ Internet: cpx

Ordering data – Product options

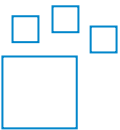

Configurable product

This product and all its product options can be ordered using the configurator.

The configurator can be found at

→ www.festo.com/catalogue/...

Enter the part number or the type.

Part no.	Type
539216	VTSA-MP-NPT
539218	VTSA-FB-NPT
547964	VTSA-F-MP-NPT
547966	VTSA-F-FB-NPT
555565	VTSA-ASI-NPT
555567	VTSA-F-ASI-NPT

Key features

Individual pneumatic connection

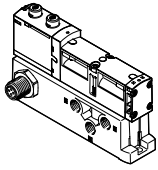

Valves on individual sub-bases up to width 52 mm can be used for actuators further away from the valve terminal.

The electrical connection is established either via a standardised 4-pin M12 plug, 24 V DC (EN 61076-2-101), a

4-pin spring-loaded terminal or a cable with open end 24 V DC, which are configured by the user.

Valve terminal with individual electrical connection

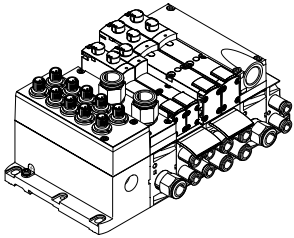

Control signals from the controller to the valve terminal are transmitted via an individual connecting cable.

The valve terminal can be equipped with a maximum of 20 valves and a maximum of 20 solenoid coils.

The electrical connection is established via a 5-pin M12 plug, 24 V DC.

Valve terminal with multi-pin plug connection:

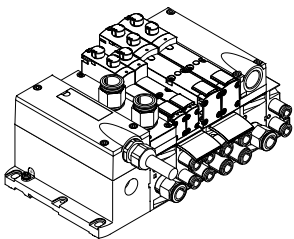

Control signals from the controller to the valve terminal are transmitted via a pre-assembled multi-core cable or a multi-pin plug connection assembled by the user (spring-loaded terminal). This substantially reduces installation time.

The valve terminal can be equipped with a maximum of 32 valves and a maximum 32 solenoid coils.

Variants

- Multi-pin plug connection with terminal strip (spring-loaded terminal), 24 V DC
- Pre-assembled connecting cable, 24 V DC
- Sub-D plug connector for assembly by the user, 37-pin
- Round plug connector M23, 19-pin, 24 V DC

AS-Interface connection

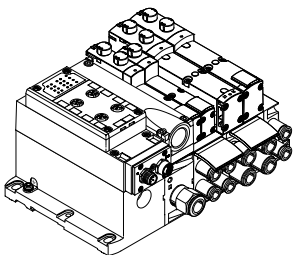

A special feature of the AS-Interface is the simultaneous transmission of data and supply power via a two-core cable. The encoded cable profile prevents connection with reverse polarity. The valve terminal with AS-Interface is available in the following versions:

- With one to eight modular valve positions (max. 8 solenoid coils). This corresponds to one to eight valves VSVA.
- With all available valve functions.

The connection technology used for the inputs can be selected as with CPX: M8, M12, Sub-D, spring-loaded terminal (terminals to IP20).

More information

→ Internet: as-interface

Note

The valve terminal VTSA/VTSA-F with AS-Interface connection is based on the same electrical links as the valve terminal with multi-pin plug connection. This means a valve terminal with multi-pin plug connection can be converted using an AS-Interface module (→ page 136). The technical specifications of the AS-Interface system must be observed in this case.

→ page 62

→ Internet: as-interface

Key features

Valve terminal with I-Port/IO-Link® connection

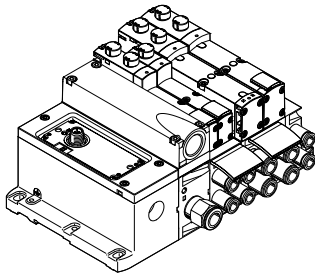

The connection to a higher-order controller can be achieved by:

- Connection to an I-Port master from Festo (e.g. CPX-CTEL)
- Direct mounting of a bus node on the I-Port interface
- Connection to an IO-Link master (in IO-Link® mode)

The valve terminal can comprise a maximum of 32 solenoid coils or 16 valve positions.

Valve terminal with fieldbus interface from the CPX system

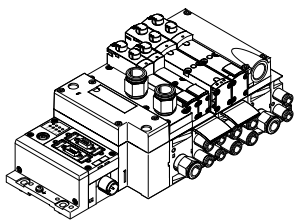

An integrated fieldbus node manages the communication connection with a higher-order PLC. This enables a space-saving pneumatic and electrical solution to be implemented.

Valve terminals with fieldbus interfaces from the CPX system can be configured with up to 16 manifold sub-bases. With 2 solenoid coils per connection, up to 32 solenoid coils can thus be actuated.

Variants

- PROFIBUS
 - DeviceNet®
 - CANopen
 - CC-Link®
 - EtherNet/IP
 - EtherCAT®
 - Modbus TCP
 - PROFINET
 - POWERLINK
 - Sercos III
- Internet: cpx

Valve terminal with control block connection from the CPX system

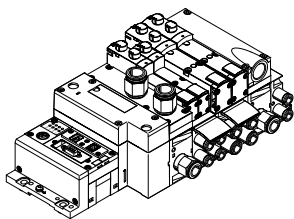

A controller integrated in the Festo valve terminal enables the construction of stand-alone control units with protection to IP65 without a control cabinet thanks to two different operating modes.

In the slave operating mode, these valve terminals can be used for intelligent preprocessing and are therefore ideal modules for designs using decentralised intelligence.

In the master operating mode, terminal groups can be designed with many options and functions that can autonomously control a medium-sized machine/system.

→ Internet: cpx

CP string extension from the CPX system

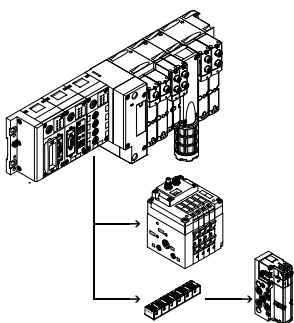

The optional CP string extension enables additional valve terminals and I/O modules to be connected to the fieldbus node of the CPX terminal on up to 4 CP strings. Different input and output modules as well as valve terminals MPA-S and CPV can be connected.

The maximum length of the CP string extension is 10 metres, which means that the extension modules can be mounted directly on-site. All the required electrical signals are transmitted via the CP cable, which in turn means that no further installation is needed on the extension module.

One CP string offers:

- 32 input signals
 - 32 output signals for output modules 24 V DC or solenoid coils
 - Logic and sensor supply for the input modules
 - Load voltage supply for the valve terminals
 - Logic supply for the output module
- Internet: cpi

Valve terminal with AP interface

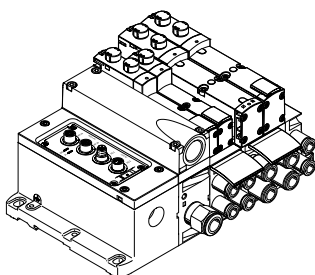

Control signals from the controller to the valve terminal are transmitted via the AP bus protocol from Festo.

The valve terminal can comprise a maximum of 24 solenoid coils or 12 valve positions.

Key features – Valves

Solenoid valve with switching position sensing, width 18 mm, 26 mm

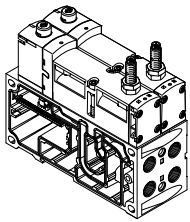

The 5/2-way single solenoid valve with spring return in width 26 mm features switching position sensing. The normal position of the piston spool is monitored.

It is available as a valve with plug-in or individual connection with pilot valves to ISO 15218 and square plug type C. This valve is not a safety device in accordance with the Machinery Directive 2006/42/EC.

It is suitable for use in safety-related parts of control systems to EN ISO 13849-1.

→ page 139

Control block with safety function, width 26 mm

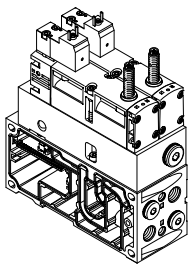

5/2-way solenoid valve
These valves are used for special applications, for example for:

- Protection against unexpected start-up
- Safe reversing
- Drives in manually loaded devices

This control block is suitable for use as a press safety valve to EN 962.

This valve is a safety device in accordance with the Machinery Directive 2006/42/EC.

→ page 149

Pilot air switching valve, width 18 mm, 26 mm

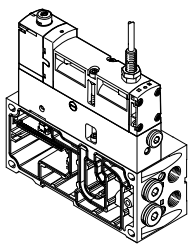

The pilot air switching valve is a combination of a 5/2-way solenoid valve with switching position sensing and the intermediate plate VABF-S4-...-S. It enables the pilot air to be verifiably switched on and off (sensing function) from duct 1 to 14 for the entire pressure zone or valve terminal.

Switching position sensing is carried out using an inductive PNP proximity switch with cable and M12x1 push-in connector to EN 61076-2-104.

This valve is not a safety device in accordance with the Machinery Directive 2006/42/EC.

It is suitable for use in safety-related parts of control systems to EN ISO 13849-1.

→ page 156

Note

The pilot air switching valve can only be operated on the valve terminal VTSA/VTSA-F in combination with a right end plate for external pilot air type VABE-S6-1RZ-.... Port 14 on the right end plate must then be sealed.

Soft-start valve, module width 43 mm

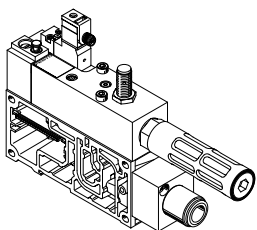

The soft-start valve is separately electrically actuated, independently of the multi-pin plug connection, AS-Interface or fieldbus interface, via a square plug of type C to EN 175301-803 or optionally via an M12 adapter.

The valve can optionally be ordered with a sensor that monitors switching of the soft-start valve. The soft-start valve can supply the valve terminal or one or more pressure zones with working air.

The pressure build-up for each pressure zone is optimised for the application directly at the valve terminal by setting the switch-over pressure and the filling time.

A maximum of 5 soft-start valves can be integrated on one valve terminal in this way.

→ page 165

Key features – Valves

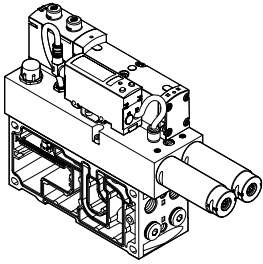
Vacuum block, module width 53 mm

5/3-way solenoid valve, with switching position 12 retained.

The vacuum block is screwed to a manifold sub-base for 2 valve positions, width 26 mm, and thus integrated into the valve terminal VTSA/VTSA-F.

The vacuum block is supplied with power and the vacuum is sensed via a standardised 4-pin M12 plug.

The vacuum block is used in conjunction with a suction gripper to pick up, hold and place components. An adjustable ejector pulse is used for setting the components down.

The vacuum block is equipped with an air saving function.

If the electrical or pneumatic supply fails, the valve moves to switching position 12 "generate vacuum".

→ page 175

5/3-way solenoid valve for special functions

For holding, blocking a movement (mechanically)

5/3-way solenoid valve for special functions; port 2 is pressurised, port 4 exhausted. Switching position 14 is retained (code SA).

5/3-way solenoid valve for special functions; port 2 is pressurised, port 4 exhausted. Switching position 12 is retained (code SE).

Possible applications:

- Using lifting cylinders
- Using rotary cylinders

Possible applications:

- Using lifting cylinders
- Using rotary cylinders

For pressureless switching, self-latching, pneumatic operation

5/3-way solenoid valve for special functions (3 phases). Mid-position is exhausted. Switching position 14 is retained.

5/3-way solenoid valve for special functions (3 phases). Mid-position is exhausted. Switching position 12 is retained.

Possible applications:

- Pneumatic manual clamps for devices (inserting stations)

Possible applications:

- Pneumatic manual clamps for devices (inserting stations)

Peripherals

Modular pneumatic peripherals

The modular design of the valve terminal VTSA/VTSA-F enables outstanding flexibility right from the planning stage and offers maximum ease of service in operation.

The system consists of manifold sub-bases and valves. The manifold sub-bases are screwed together, thus forming the support system for the valves.

Inside the manifold sub-bases are the connection ducts for supplying compressed air to and exhausting the valve terminal as well as the working ports for the pneumatic cylinders for each valve.

Each manifold sub-base is connected to the next using four screws. Individual valve terminal sections can be isolated and further blocks easily inserted by loosening these screws. This ensures that the valve terminal can be rapidly and reliably extended.

Basic system modularity

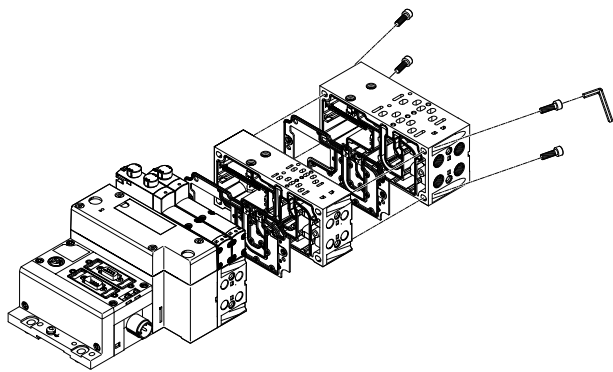

Valve modularity

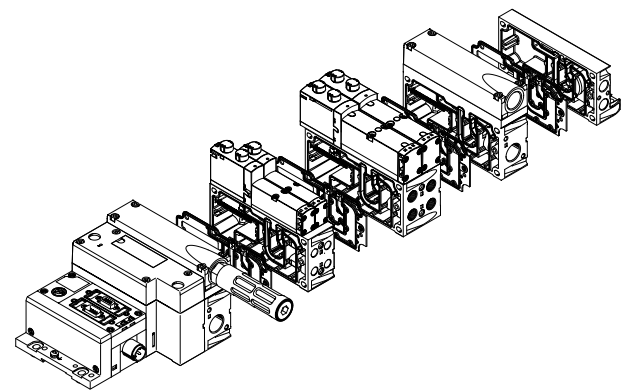

Vertical stacking modularity

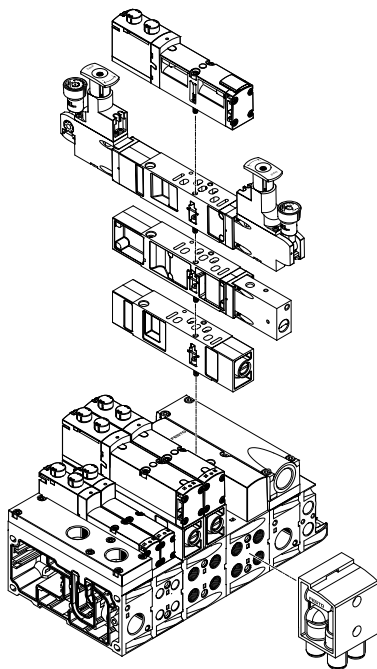

Peripherals

Modular electrical peripherals

The valves are actuated differently depending on whether a multi-pin terminal or fieldbus terminal is used.

The VTSA/VTSA-F with CPX interface is based on the internal bus system of the CPX and uses this communication system for all solenoid coils and a range of electrical input and output functions.

Parallel links enable the following:

- Transmission of switching information
- Compact design
- Position-based diagnostics
- Separate power supply for valves

- Flexible conversion without address shifting
 - Option of CP interface
 - CPX-CEC as stand-alone controller with access via Ethernet and web server
 - Transmission of status, parameter and diagnostic data
- Internet: cpx

VTSA/VTSA-F with electrical peripherals CPX

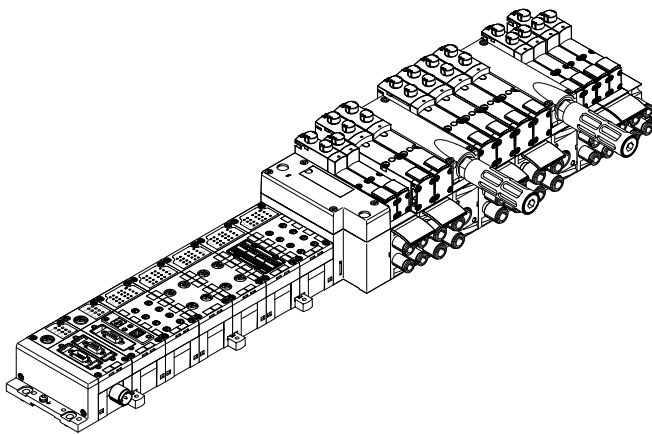

Modularity with electrical peripherals CPX

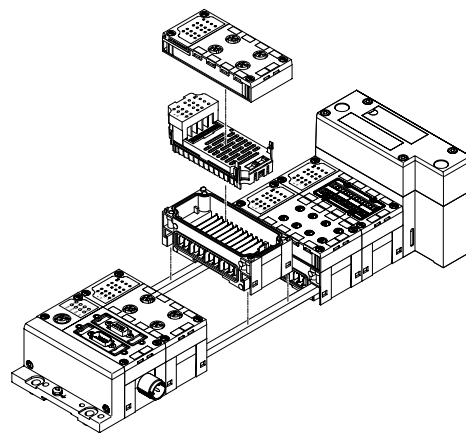

CPX terminal in metal design

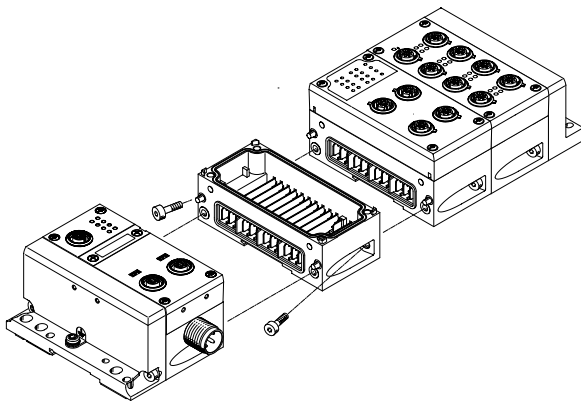

The metal CPX modules are mechanically connected using an angled fitting.

The CPX terminal can thus be expanded at any time.

Note

The CPX connection blocks are also available in metal. This means a complete solution in a sturdy metal design can be selected for applications of the valve terminal VTSA/VTSA-F in welding environments.

Peripherals – Pneumatic components

Valve terminal widths

Order code for VTSA:

- 44E... for the electric components
- 44P... for the pneumatic components

Order code for VTSA-F:

- 45E... for the electric components
- 45P... for the pneumatic components

Regardless of the type of control (e.g. multi-pin plug, fieldbus, etc.), valve terminals VTSA/VTSA-F

of widths

- 18 mm
- 26 mm
- 42 mm
- 52 mm

can be combined without adapters.

This enables a flow range for the VTSA of:

400 l/min to 2900 l/min

For the VTSA-F of:

700 l/min to 2900 l/min

to be covered on one valve terminal. A wide range of valve functions and vertical stacking components are available for all widths.

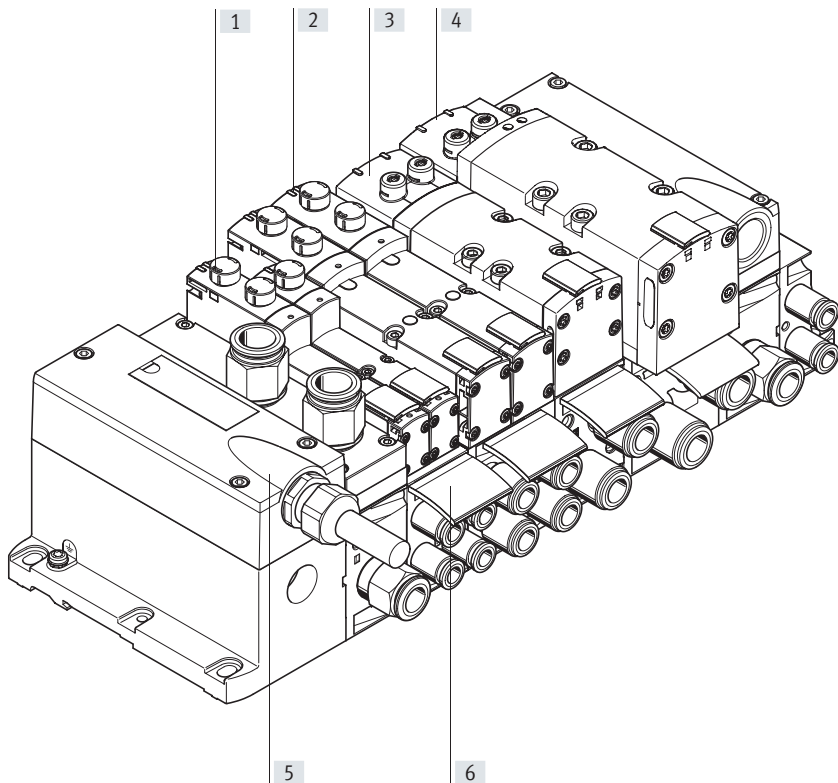

		Description	→ Page/Internet
[1]	Valve	Width 18 mm	99
[2]	Valve	Width 26 mm	107
[3]	Valve	Width 42 mm	115
[4]	Valve	Width 52 mm	122
[5]	Multi-pin plug connection	Via multi-pin cable, 24 V DC	136
[6]	Inscription labels	For manifold sub-base, connecting plate, angled connection plate	138

Peripherals – Pneumatic components

Individual sub-base, width 18 mm, ISO 15407-2

Order code:

- Using individual part numbers

Individual sub-bases can be equipped with any valve.

Width 18 mm with spring-loaded terminal or cable (open end)

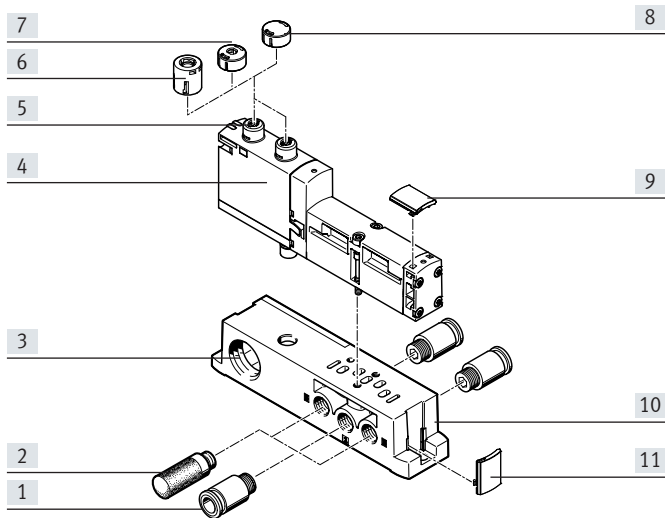

		Description	→ Page/Internet
[1]	Fitting	1/8 NPT for working air/exhaust ports (1, 3, 5) and working ports (2, 4)	190
[2]	Silencer	U-1/8-B-NPT for exhaust ports (3, 5)	191
[3]	Electrical connection	Spring-loaded terminal, cable (open end)	–
[4]	Valve VSVA	Width 18 mm	99
[5]	Manual override	Non-detenting/detenting, per solenoid coil	–
[6]	Cover cap, heavy duty	For manual override, non-detenting heavy duty, detenting via accessory	135
[7]	Cover cap, coded	For non-detenting manual override (limited function)	135
[8]	Cover cap, concealed	MO concealed by cover cap – operation of MO prevented	135
[9]	Inscription label holder	For valves	138
[10]	Individual sub-base	For valve VSVA	189
[11]	Inscription label holder	For manifold block	138

Peripherals – Pneumatic components

Individual sub-base, width 26 mm, ISO 15407-2

With spring-loaded terminal or cable (open end)

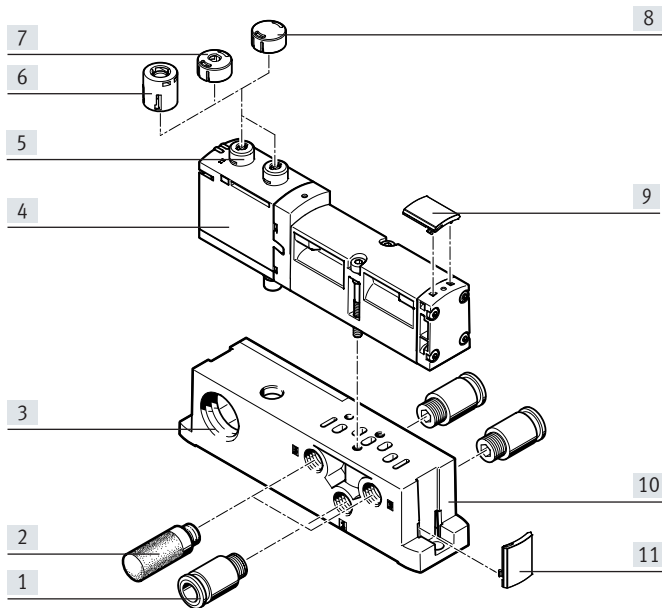

		Description	→ Page/Internet
[1]	Fitting	1/4 NPT for working air/exhaust ports (1, 3, 5) and working ports (2, 4)	190
[2]	Silencer	U-1/4-B-NPT for exhaust ports (3, 5)	191
[3]	Electrical connection	Spring-loaded terminal, cable (open end)	–
[4]	Valve VSVA	Width 26 mm	107
[5]	Manual override	Non-detenting/detenting, per solenoid coil	–
[6]	Cover cap, heavy duty	For manual override, non-detenting heavy duty, detenting via accessory	135
[7]	Cover cap, coded	For non-detenting manual override (limited function)	135
[8]	Cover cap, concealed	MO concealed by cover cap – operation of MO prevented	135
[9]	Inscription label holder	For valves	138
[10]	Individual sub-base	For valve VSVA	189
[11]	Inscription label holder	For manifold block	138

Peripherals – Pneumatic components

Individual sub-base, width 42 mm, ISO 5599-2

With spring-loaded terminal or cable (open end)

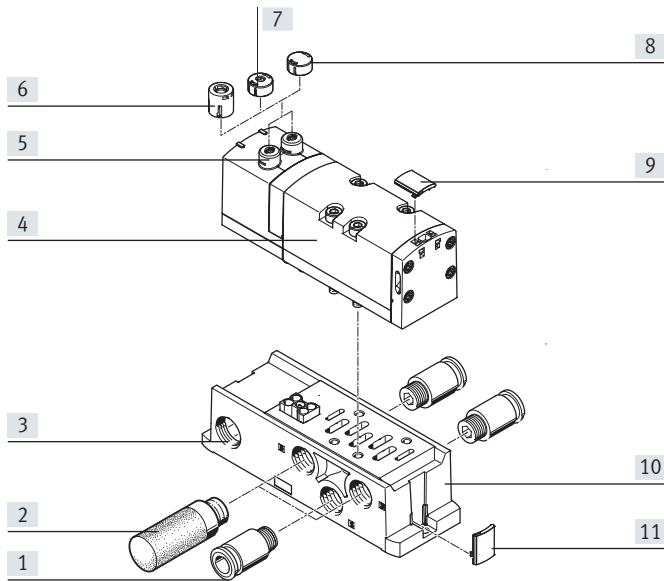

		Description	→ Page/Internet
[1]	Fitting	3/8 NPT for working air/exhaust ports (1, 3, 5) and working ports (2, 4)	190
[2]	Silencer	U-3/8-B-NPT for exhaust ports (3, 5)	191
[3]	Electrical connection	Spring-loaded terminal, cable (open end)	–
[4]	Valve VSVA	Width 42 mm	115
[5]	Manual override	Non-detenting/detenting, per solenoid coil	–
[6]	Cover cap, heavy duty	For manual override, non-detenting heavy duty, detenting via accessory	135
[7]	Cover cap, coded	For non-detenting manual override (limited function)	135
[8]	Cover cap, concealed	MO concealed by cover cap – operation of MO prevented	135
[9]	Inscription label holder	For valves	138
[10]	Individual sub-base	For valve VSVA	189
[11]	Inscription label holder	For manifold block	138

Peripherals – Pneumatic components

Individual sub-base, width 52 mm, ISO 5599-2

With spring-loaded terminal or cable (open end)

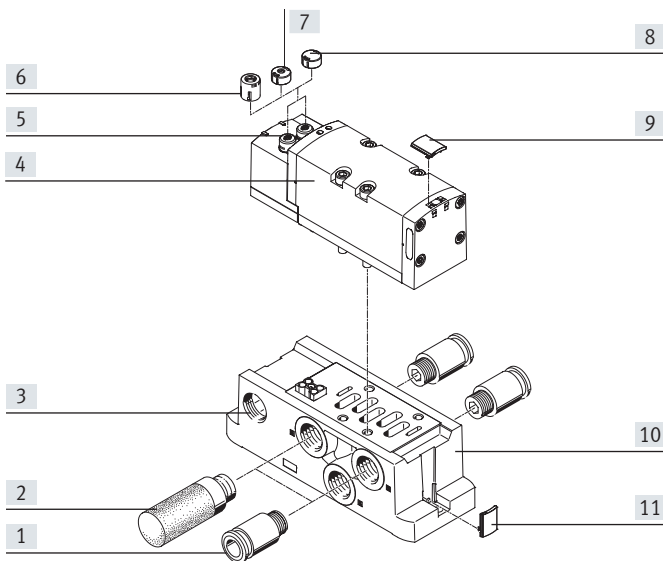

		Description	→ Page/Internet
[1]	Fitting	1/2 NPT for working air/exhaust ports (1, 3, 5) and working ports (2, 4)	190
[2]	Silencer	U-1/2-B-NPT for exhaust ports (3, 5)	191
[3]	Electrical connection	Spring-loaded terminal, cable (open end)	–
[4]	Valve VSVA	Width 52 mm	122
[5]	Manual override	Non-detenting/detenting, per solenoid coil	–
[6]	Cover cap, heavy duty	For manual override, non-detenting heavy duty, detenting via accessory	135
[7]	Cover cap, coded	For non-detenting manual override (limited function)	135
[8]	Cover cap, concealed	MO concealed by cover cap – operation of MO prevented	135
[9]	Inscription label holder	For valves	138
[10]	Individual sub-base	For valve VSVA	189
[11]	Inscription label holder	For manifold block	138

Peripherals – Pneumatic components

Pneumatic components of the valve terminal

The manifold sub-bases for valves with a width of 18 or 26 mm are suitable for either

- 2 single solenoid valves or
- 2 double solenoid valves depending on the size.

The manifold sub-bases for valves with a width of 42 or 52 mm are suitable for

- 1 single solenoid valve or
- 1 double solenoid valve

- Double solenoid valve positions can be equipped with any valve or a blanking plate.

- Single solenoid valve positions can only be equipped with single solenoid valves or a blanking plate.

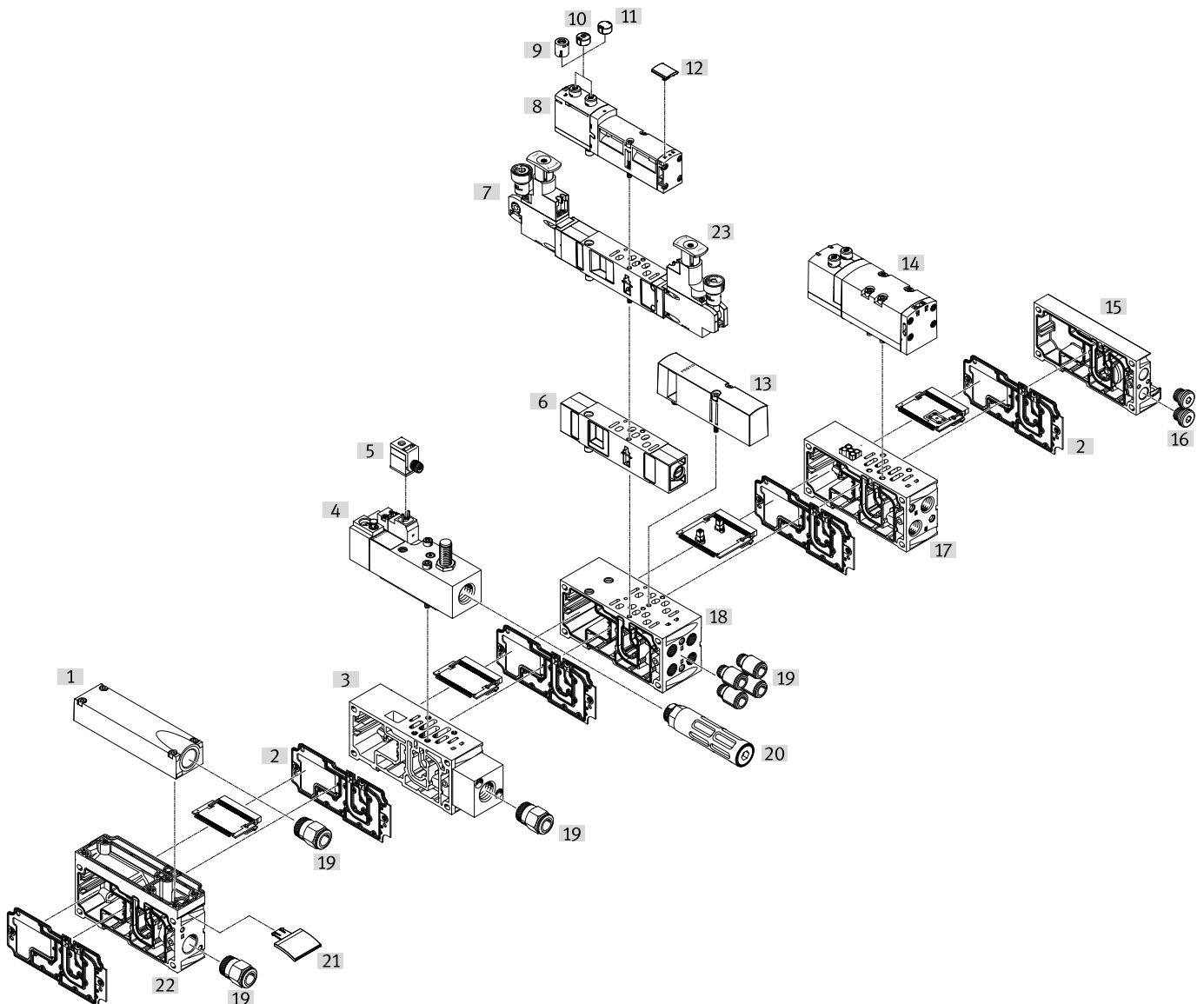

Peripherals – Pneumatic components

Pneumatic components of the valve terminal		Description	→ Page/Internet
[1]	Exhaust port cover	For ducted exhaust air (ports 3 and 5 combined)	130
[2]	Duct separation/seal	–	130
[3]	Manifold sub-base	For soft-start valve	173
[4]	Soft-start valve	For slow and safe pressure build-up	173
[5]	Plug socket	–	174
[6]	Throttle plate	–	135
[7]	Pressure regulator plate	–	131
[8]	Valve	Width 18 mm or 26 mm	99, 107
[9]	Cover cap, heavy duty	For manual override, non-detenting heavy duty, detenting via accessory	135
[10]	Cover cap, coded	For non-detenting manual override (limited function)	135
[11]	Cover cap, concealed	MO concealed by cover cap – operation of MO prevented	135
[12]	Inscription label holder	For valve	138
[13]	Cover plate	For unused valve position (vacant position)	135
[14]	Valve	Width 42 mm or 52 mm	115, 122
[15]	End plate with pilot air selector	–	129
[16]	Blanking plug	–	191
[17]	Manifold sub-base VTSA	For valves with a width of 42 mm or 52 mm	129
[17]	Manifold sub-base VTSA-F	For valves with a width of 42 mm or 52 mm	129
[18]	Manifold sub-base VTSA	For valves with a width of 18 mm or 26 mm	129
[18]	Manifold sub-base VTSA-F	For valves with a width of 18 mm or 26 mm	129
[19]	Fittings	–	190
[20]	Silencer	–	191
[21]	Inscription label holder	For manifold sub-base, connecting plate, angled connection plate	138
[22]	Supply plate	–	130
[23]	Control element	Regulator knobs in different versions	34

 **Note**

Special applications for the valve terminal, such as:

- Solenoid valve with switching position sensing
- Control block with safety function
- Pilot air switching valve
- Soft-start valve
- Vacuum block

are listed after → Accessories – General

Peripherals – Electrical components

Valve terminal with individual electrical connection

Order code for VTSA:

- 44E... for the electric components
- 44P... for the pneumatic components

Order code for VTSA-F:

- 45E... for the electric components
- 45P... for the pneumatic components

Valve terminals VTSA/VTSA-F with individual electrical connection can be expanded with up to 20 valves with max. 20 solenoid coils.

The manifold sub-bases for valves with a width of 18 or 26 mm are suitable for either

- 2 single solenoid valves or
 - 2 double solenoid valves
- and the manifold sub-bases for valves with a width of 42 or 52 mm are suitable for

- 1 single solenoid valve or
 - 1 double solenoid valve
- depending on the size.

- Double solenoid valve positions can be equipped with any valve or a blanking plate.
- Single solenoid valve positions can only be equipped with single solenoid valves or a blanking plate.
- The electrical connection is established via a 5-pin M12 plug (24 V DC).

		Description	→ Page/Internet
[1]	Cover	For individual connection	136
[2]	Multi-pin plug connection	Individual connection with M12, 10-way or 6-way (including cover)	136

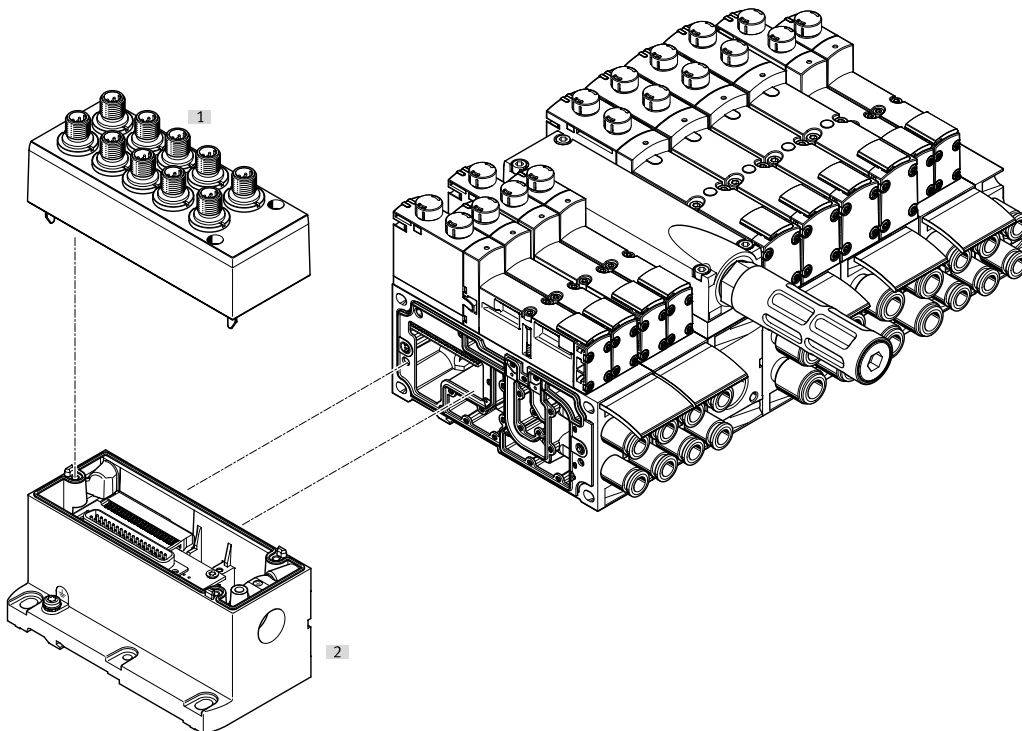

Peripherals – Electrical components

Valve terminal with electrical multi-pin plug connection

Order code for VTSA:

- 44E... for the electric components
- 44P... for the pneumatic components

Order code for VTSA-F:

- 45E... for the electric components
- 45P... for the pneumatic components

Valve terminals VTSA/VTSA-F with electrical multi-pin plug connection can be expanded with up to 32 valves with max. 32 solenoid coils. The manifold sub-bases for valves with a width of 18 or 26 mm are suitable for

- 2 single solenoid valves or
- 2 double solenoid valves

and the manifold sub-bases for valves with a width of 42 or 52 mm are suitable for

- 1 single solenoid valve or
- 1 double solenoid valve

- Double solenoid valve positions can be equipped with any valve or a blanking plate.

- Single solenoid valve positions can only be equipped with single solenoid valves or a blanking plate.

- The following multi-pin plug connections to IP65 are available:

- 37-pin Sub-D connection (24 V DC): the connecting cable can be ordered in lengths of 2.5 m, 5 m and 10 m for max. 8, 22 or 32 solenoid coils respectively.

- Terminal strip (24 V DC), 19-pin round plug connector (24 V DC)

		Description	→ Page/Internet
[1]	Inscription labels	Large, for multi-pin plug connection	–
[2]	Multi-pin cable	–	137
[3]	Multi-pin plug connection	Via M23 round plug connection, 24 V DC	136
[4]	Multi-pin plug connection	Via terminal strip (CageClamp) 24 V DC	136
[5]	Multi-pin plug connection	Via multi-pin cable, 24 V DC	136

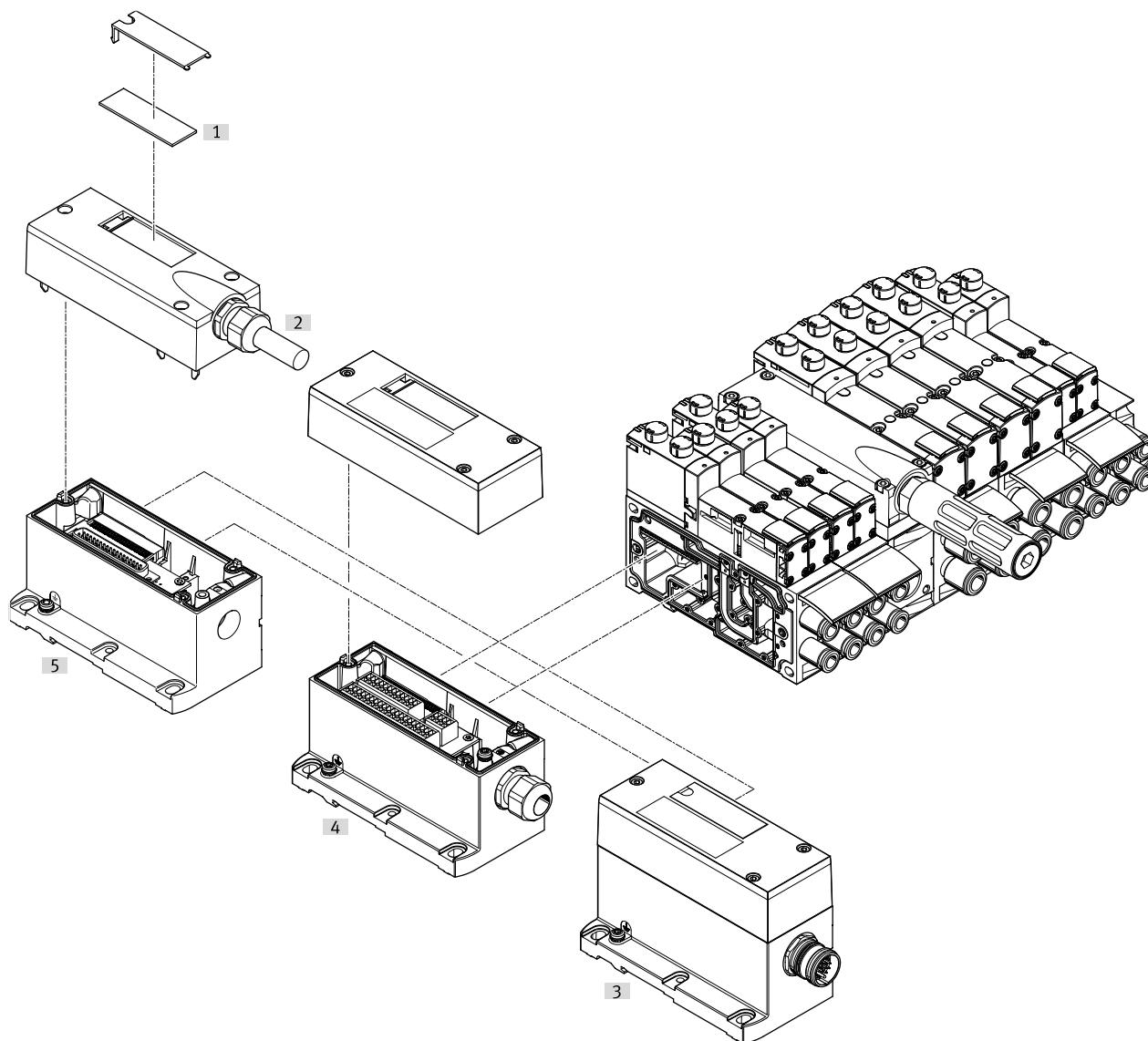

Peripherals – Electrical components

Valve terminal with AS-Interface connection

Order code for VTSA:

- 52E... for the electric components
- 44P... for the pneumatic components

Order code for VTSA-F:

- 52E... for the electric components
- 45P... for the pneumatic components

Valve terminals VTSA/VTSA-F with AS-Interface connection can be expanded with up to 8 valves with max. 8 solenoid coils.

The manifold sub-bases for valves with a width of 18 or 26 mm are suitable for either

- 2 single solenoid valves or
- 2 double solenoid valves

and the manifold sub-bases for valves with a width of 42 or 52 mm are suitable for

- 1 single solenoid valve or
- 1 double solenoid valve depending on the size.

- Double solenoid valve positions can be equipped with any valve or a blanking plate.
- Single solenoid valve positions can only be equipped with single solenoid valves or a blanking plate.

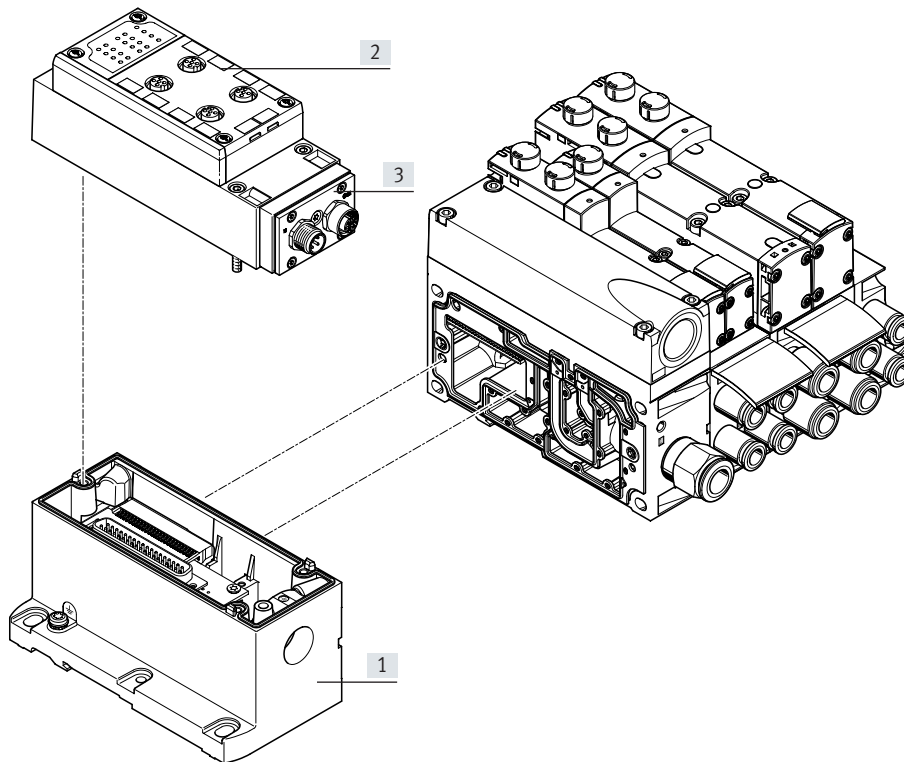

		Description	→ Page/Internet
[1]	Multi-pin plug connection	Can be ordered together with the AS-Interface module as an electrical connection for AS-Interface	136
[2]	Connection block for AS-Interface	–	137
[3]	AS-Interface module	–	136

Peripherals – Electrical components

Valve terminal with I-Port/IO-Link® connection

Order code for VTSA:

- 44E... for the electric components
- 44P... for the pneumatic components

Order code for VTSA-F:

- 45E... for the electric components
- 45P... for the pneumatic components

Valve terminals VTSA/VTSA-F with I-Port/IO-Link® connection can be expanded with up to 16 valves with max. 32 solenoid coils. The manifold sub-bases for valves with a width of 18 or 26 mm are suitable for either

- 2 single solenoid valves or
- 2 double solenoid valves

and the manifold sub-bases for valves with a width of 42 or 52 mm are suitable for

- 1 single solenoid valve or
- 1 double solenoid valve

depending on the size.

- Double solenoid valve positions can be equipped with any valve or a blanking plate.
- Single solenoid valve positions can only be equipped with single solenoid valves or a blanking plate.

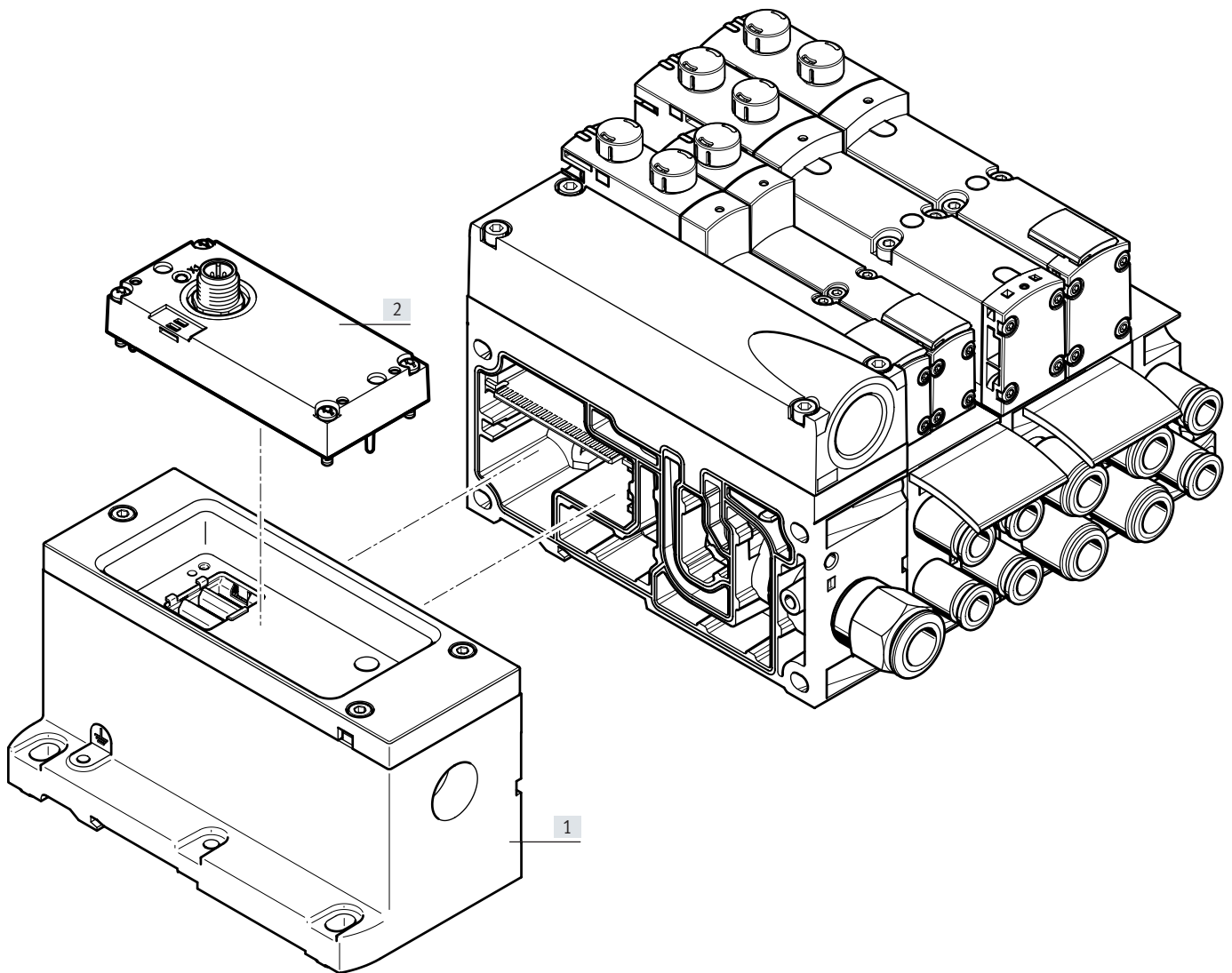

	Description	→ Page/Internet
[1]	Multi-pin plug connection	136
[2]	I-Port/IO-Link® connection	136

Peripherals – Electrical components

Valve terminal with AP interface

- Order code for VTSA:
- 44E... for the electric components
 - 44P... for the pneumatic components
- Order code for VTSA-F:
- 45E... for the electric components
 - 45P... for the pneumatic components

VTSA/VTSA-F valve terminals with AP interface can be expanded with up to 12 valves with a maximum of 24 solenoid coils. The manifold sub-bases for valves with a width of 18 or 26 mm are suitable for either

- 2 single solenoid valves or
- 2 double solenoid valves

and the manifold sub-bases for valves with a width of 42 or 52 mm are suitable for

- 1 single solenoid valve or
- 1 double solenoid valve

depending on the size.

- Double solenoid valve positions can be equipped with any valve or a blanking plate.
- Single solenoid valve positions can only be equipped with single solenoid valves or a blanking plate.

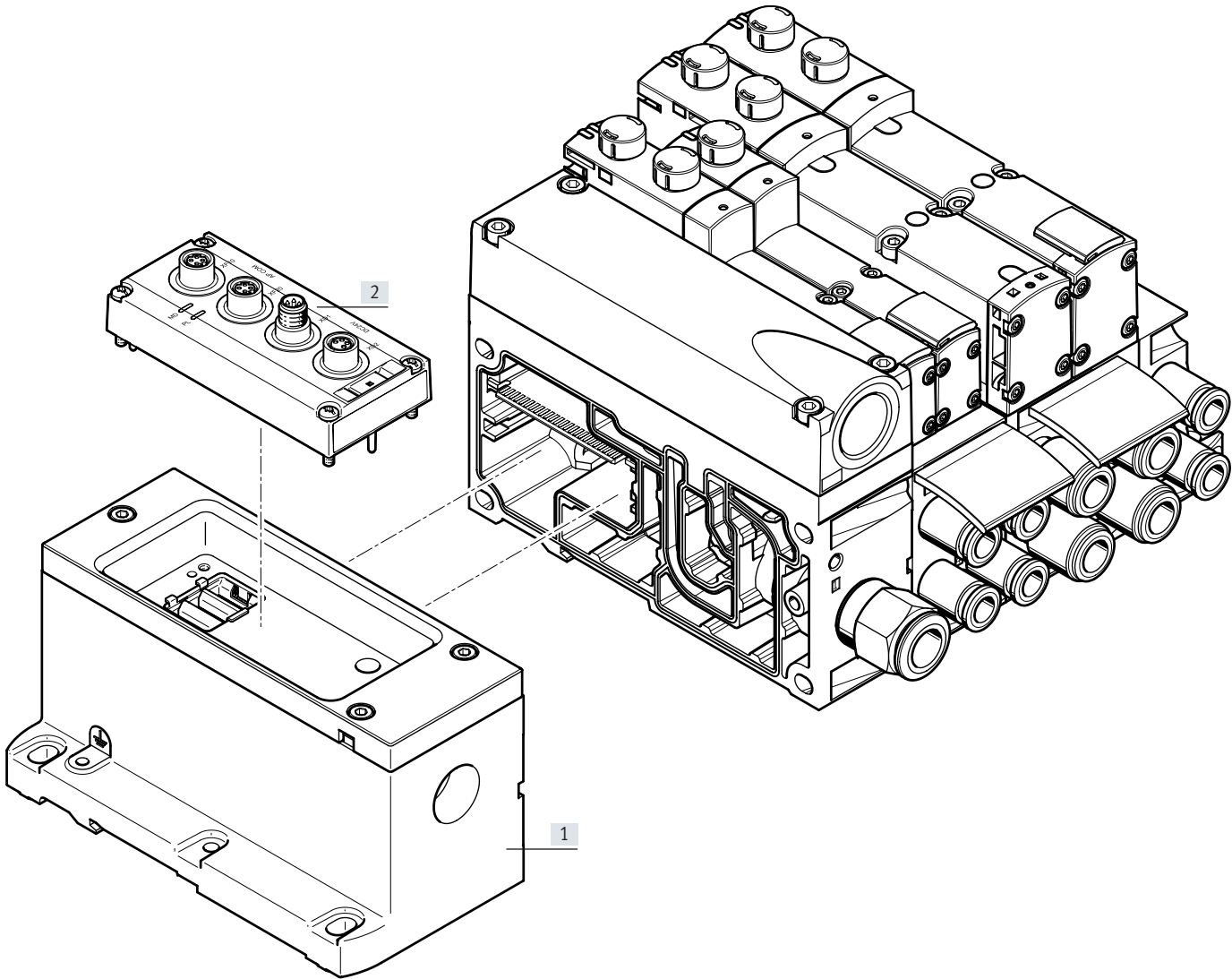

	Description	→ Page/Internet
[1]	Multi-pin plug connection	136
[2]	AP interface	72

Peripherals – Electrical components

Valve terminal with fieldbus interface, control block (electrical peripherals CPX)

Order code:

- 50E-... for the electrical peripherals, polymer variant
- 51E-... for the electrical peripherals, metal variant
- 53E-... for the electrical peripherals, for control cabinet installation

For VTSA:

- 44P-... for the pneumatic components

For VTSA-F:

- 45P-... for the pneumatic components

Valve terminals VTSA/VTSA-F with fieldbus interface can be expanded with up to 32 valves with max. 32 solenoid coils.

The manifold sub-bases for valves with a width of 18 or 26 mm are suitable for either

- 2 single solenoid valves or
 - 2 double solenoid valves
- and the manifold sub-bases for valves with a width of 42 or 52 mm are suitable for

- 1 single solenoid valve or
 - 1 double solenoid valve
- depending on the size.

- Double solenoid valve positions can be equipped with any valve or a blanking plate.
- Single solenoid valve positions can only be equipped with single solenoid valves or a blanking plate.

Each valve position can be equipped with any valve or a blanking plate. The rules for CPX apply to the equipment that can be used with the electrical peripherals CPX.

In general:

- Max. 10 electrical modules
- Digital inputs/outputs
- Analogue inputs/outputs

- Parameterisation of inputs and outputs
- Integrated, convenient diagnostics
- Preventive maintenance concepts

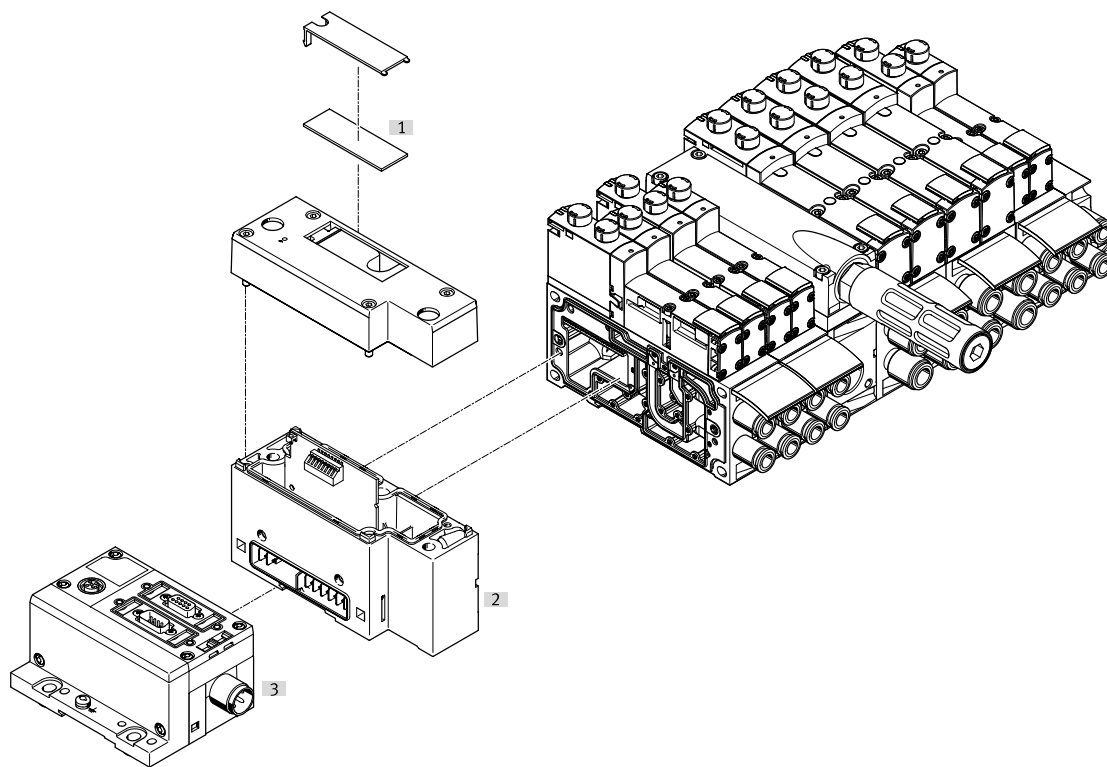

	Description	→ Page/Internet
[1]	Inscription labels Large, for pneumatic interface CPX	–
[2]	Pneumatic interface	136
[3]	Fieldbus interface	cpX

Peripherals – Electrical components

Valve terminal with fieldbus/multi-pin plug connection and individually electrically actuated valve

In applications with specific emergency off conditions, it may be necessary to switch one or more valves separately from the valve terminal controller.

Standards-based valves (VSVA) with individual electrical connection (round or square plug) are therefore mounted on the valve terminal.

In order for degree of protection IP65 to be achieved, the functionless opening in the sub-base for the electrical connection must be sealed.

A sealing cap is available for width 18 mm and 26 mm.

With manifold or individual sub-bases, valves with width 42 mm and 52 mm must be used with a seal to comply with the IP protection class (see → page 135).

For centrally controlling the valve terminal via a multi-pin plug connection or fieldbus interface, the occupied valve position acts like a vacant position, i.e. the assigned address in the fieldbus node or the corresponding connection in the multi-pin plug connection is occupied.

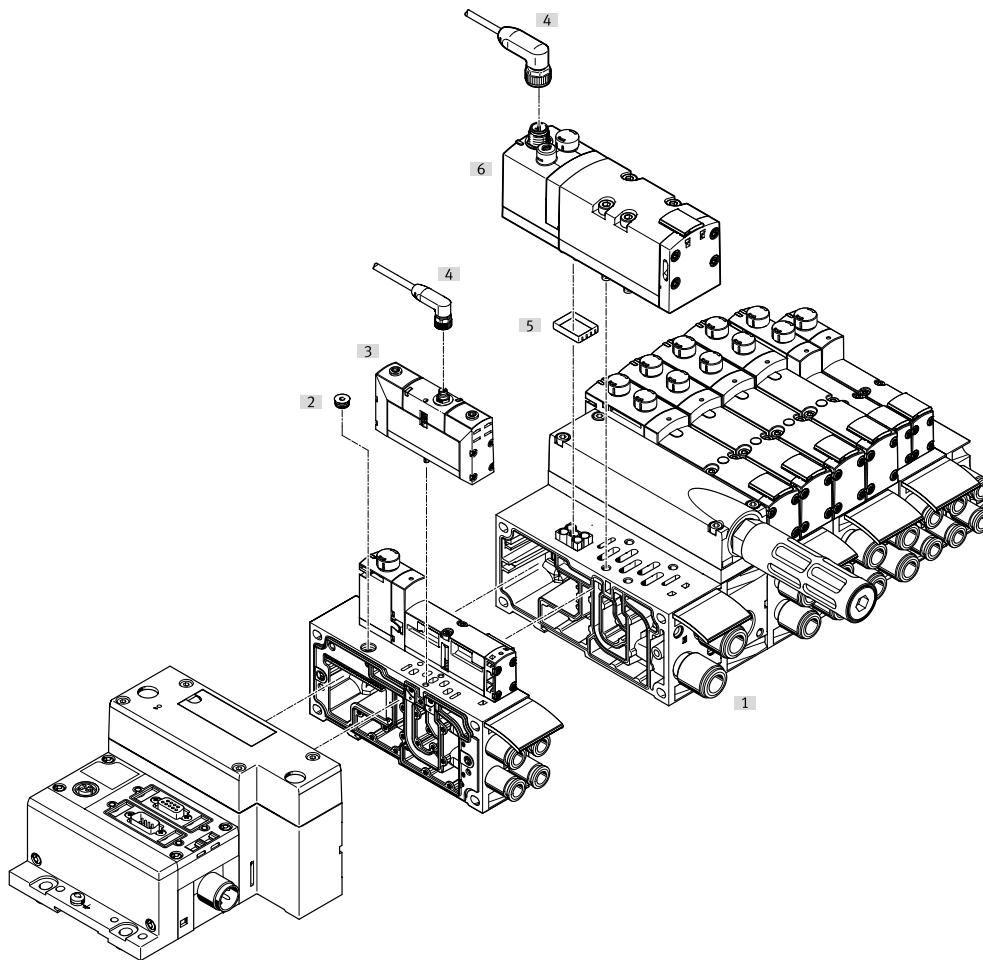

		Description	→ Page/Internet
[1]	Valve terminal	Valve terminal with fieldbus/multi-pin plug connection and individually electrically actuated valve	–
[2]	Sealing cap	For sealing the electrical connection on the sub-base	135
[3]	Valve	Width 18 mm or width 26 mm	vsva
[4]	Connecting cable	–	vsva
[5]	Seal	For ensuring the IP degree of protection (with width 42 mm and 52 mm)	135
[6]	Valve	Width 42 mm or width 52 mm	vsva

- Note

Standards-based valves VSVA can be used on the valve terminal. A vacant position must be provided for this in the valve terminal configurator.

The appropriate standards-based valve VSVA can be ordered on the Internet at:

→ vsva

Key features – Pneumatic components

Manifold sub-base

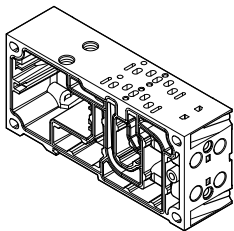

VTSA/VTSA-F is based on a modular system which consists of manifold sub-bases and valves. The VTSA-F manifold sub-bases are designed to optimise the flow rate. Manifold sub-bases are available for valve widths 18 mm and 26 mm in a double grid, i.e. two valves per manifold sub-base. For valves with a width of 42 mm or 52 mm, there are manifold sub-bases with one valve per sub-base. The manifold sub-base contains

a duct seal and an electrical linking module. They can be freely mixed within a valve terminal. The manifold sub-bases are screwed together, thus forming the support system for the valves. Inside the manifold sub-bases are the connection ducts for supplying compressed air to and exhausting the valve terminal as well as the working ports for the pneumatic cylinders for each valve. Each manifold sub-base is connected to the next using four

manifold. Individual valve terminal sections can be isolated and further manifold sub-bases can be inserted by loosening these screws. This ensures that the valve terminal can be rapidly and reliably extended.

Port patterns to ISO 154072

Width 18 mm (size 02)

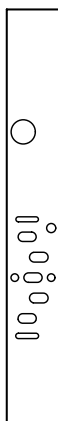

Width 26 mm (size 01)

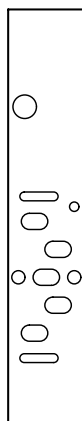

Port patterns to ISO 55992

Width 42 mm (size 1)

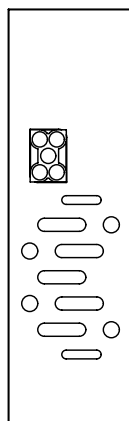

Width 52 mm (size 2)

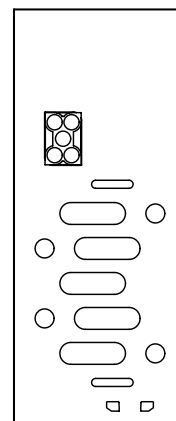

Port patterns – High-flow sub-bases with optimised flow rate (no standard)

Width 18 mm

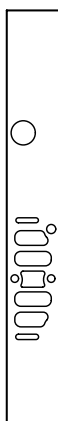

Width 26 mm

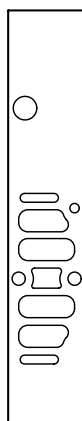

Width 42 mm

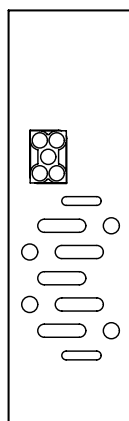

- - Note

The illustrations show the pneumatic ISO port patterns. The port patterns on the valve terminal VTSA-F do not correspond to the ISO standard.

Key features – Pneumatic components

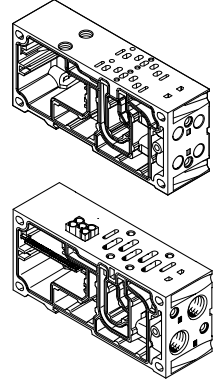
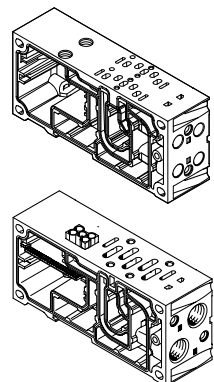
Manifold sub-base variants with QS fitting, valve terminal VTSA									
Code		Type	Width				No. of valve positions (solenoid coils) ¹⁾	Working ports (2, 4)	
			18 mm	26 mm	42 mm	52 mm		Code M Large	Code N Small
Manifold sub-base for double solenoid valves									
A		VABV-S4-2S-N18-2T2	■	–	–	–	2 (4)	QB-1/8-5/16-U	–
AK								–	QB-1/8-1/4-U
B		VABV-S4-1S-N14-2T2	–	■	–	–	2 (4)	QB-1/4-3/8-U	–
BK								–	QB-1/4-5/16-U
C		VABV-S2-1S-N38-T2	–	–	■	–	1 (2)	QB-3/8-1/2-U	–
CK								–	QB-3/8-3/8-U
D	VABV-S2-2S-N12-T2	–	–	–	■	1 (2)	QB-1/2-1/2-U	–	
DK							–	–	
Manifold sub-base for single solenoid valves									
E		VABV-S4-2S-N18-2T1	■	–	–	–	2 (2)	QB-1/8-5/16-U	–
EK								–	QB-1/8-1/4-U
F		VABV-S4-1S-N14-2T1	–	■	–	–	2 (2)	QB-1/4-3/8-U	–
FK								–	QB-1/4-5/16-U
G		VABV-S2-1S-N38-T1	–	–	■	–	1 (1)	QB-3/8-1/2-U	–
GK								–	QB-3/8-3/8-U
H	VABV-S2-2S-N12-T1	–	–	–	■	1 (1)	QB-1/2-1/2-U	–	
HK							–	–	

1) The value in brackets is the max. number of solenoid coils that can be actuated

Key features – Pneumatic components

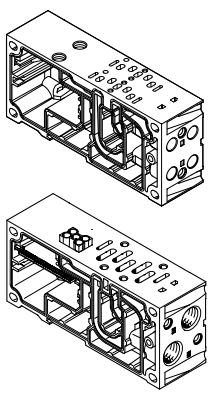
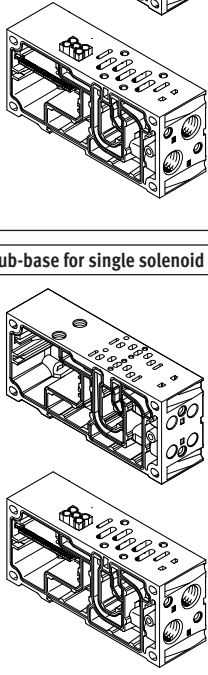
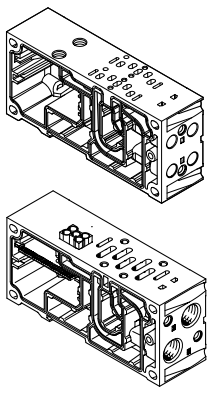
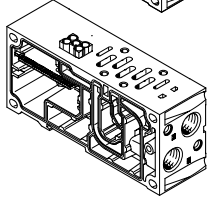
Manifold sub-base variants with QS fitting, valve terminal VTSA-F									
Code	Type	Width				No. of valve positions (solenoid coils) ¹⁾	Working ports (2, 4)		
		18 mm	26 mm	42 mm	52 mm		Code M Large	Code N Small	
Manifold sub-base for double solenoid valves									
A		VABV-S4-2S-G18-2T2	■	-	-	-	2 (4)	QS-G1/8-8	-
AK								-	QS-G1/8-6
B		VABV-S4-1S-G14-2T2	-	■	-	-	2 (4)	QS-G1/4-10	-
BK								-	QS-G1/4-8
C		VABV-S2-1S-G38-T2	-	-	■	-	1 (2)	QS-G3/8-12	-
CK								-	QS-G3/8-10
D		VABV-S2-2S-G12-T2	-	-	-	■	1 (2)	QS-G1/2-16	-
DK								-	QS-G1/2-12
Manifold sub-base for single solenoid valves									
E		VABV-S4-2S-G18-2T1	■	-	-	-	2 (2)	QS-G1/8-8	-
EK								-	QS-G1/8-6
F		VABV-S4-1S-G14-2T1	-	■	-	-	2 (2)	QS-G1/4-10	-
FK								-	QS-G1/4-8
G		VABV-S2-1S-G38-T1	-	-	■	-	1 (1)	QS-G3/8-12	-
GK								-	QS-G3/8-10
H		VABV-S2-2S-G12-T1	-	-	-	■	1 (1)	QS-G1/2-16	-
HK								-	QS-G1/2-12

1) The value in brackets is the max. number of solenoid coils that can be actuated

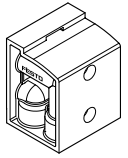
Angled connection plate for working ports 2 and 4 with NPT thread									
Code	Type	Width				Connections	Working ports (2, 4) on the angled connection plate		
		18 mm	26 mm	42 mm	52 mm				
P		VABF-S4-...A2G2-N...	■	-	-	-	2 and 4	1/8 NPT	
			-	■	-	-		1/4 NPT	
			-	-	■	-		3/8 NPT	
			-	-	-	■		1/2 NPT	

Key features – Pneumatic components

Sub-base valve

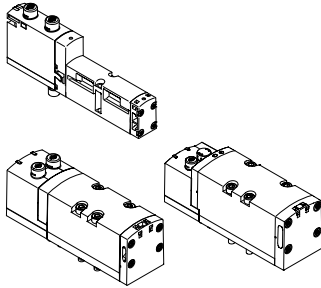

All valves have a piston spool and patented sealing system, which ensures efficient sealing, a broad operating pressure range and long service life.

Sub-base valves can be quickly replaced since the tubing connections remain on the manifold sub-base.

Irrespective of the valve function, there are sub-base valves with one solenoid coil (single solenoid) or with two solenoid coils for double solenoid or double valve functions.

Reverse/vacuum operation

Select reverse operation (code Z) if you wish to operate an actuator (cylinder) with different pressures for the forward and return stroke.

Please note that the valves must then be operated via a separate pressure zone.

The reversible 3/2-way solenoid valves are also suitable for vacuum operation.

Reverse operation is only possible in pressure zones with external pilot air supply.

Note

- If a pressure zone is in reverse operation, the supply pressure is connected to port 3/5 and the air is exhausted via port 1 at all valve positions in this pressure zone.
- Reversible pressure regulators cannot be selected when a pressure zone is in reverse operation.
- With reversible pressure regulators, only the valve at this position is in reverse operation.
- When using 5/3-way valves in reverse operation, the mid-position function switches from exhausted to pressurised and vice versa.

Cover plate

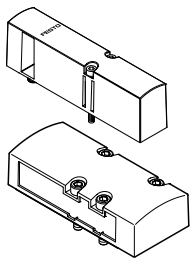

Plate without valve function for reserving valve positions on a valve terminal.

Valve and blanking plates are mounted on the manifold sub-base using screws.

Design

Replacing valves

The valves are attached to the metal manifold sub-base using two or four screws, which means that they can be easily replaced.

The sturdy mechanical structure of the sub-base ensures efficient, durable sealing.

Extension

Vacant positions can be fitted with valves at a later date. The dimensions, mounting points and existing pneumatic installations remain unchanged during this process.

For more information and technical data on extension, refer to the user manual:

→ Internet: VTSA/VTSA-F

Key features – Pneumatic components

Valve function		Valve code	Width				Description
Terminal code	Circuit symbol		18 mm	26 mm	42 mm	52 mm	
VC		T22C	■	■	■	■	2x 2/2-way valve, single solenoid <ul style="list-style-type: none"> • Normally closed • Pneumatic spring return
VV		T22CV	■	■	■	–	2x 2/2-way valve, single solenoid <ul style="list-style-type: none"> • Reverse operation • Normally closed • Pneumatic spring return • Vacuum operation possible at 3 and 5
N		T32U	■	■	■	■	2x 3/2-way valve, single solenoid <ul style="list-style-type: none"> • Normally open • Pneumatic spring return • Operating pressure > 3 bar
K		T32C	■	■	■	■	2x 3/2-way valve, single solenoid <ul style="list-style-type: none"> • Normally closed • Pneumatic spring return • Operating pressure > 3 bar
H		T32H	■	■	■	■	2x 3/2-way valve, single solenoid <ul style="list-style-type: none"> • Normal position <ul style="list-style-type: none"> – 1x normally closed – 1x normally open • Pneumatic spring return • Operating pressure > 3 bar
P		T32F	■	■	■	■	2x 3/2-way valve, single solenoid <ul style="list-style-type: none"> • Reverse operation only • Normally open • Pneumatic spring return
Q		T32N	■	■	■	■	2x 3/2-way valve, single solenoid <ul style="list-style-type: none"> • Reverse operation only • Normally closed • Pneumatic spring return
R		T32W	■	■	■	■	2x 3/2-way valve, single solenoid <ul style="list-style-type: none"> • Reverse operation only • Normal position <ul style="list-style-type: none"> – 1x normally closed – 1x normally open • Pneumatic spring return

Note

A filter must be installed upstream of valves operated in vacuum mode. This prevents any foreign matter in the intake air getting into the valve (e.g. when operating a suction cup).

Key features – Pneumatic components

Valve function		Valve code	Width				Description
Terminal code	Circuit symbol		18 mm	26 mm	42 mm	52 mm	
M		M52-A	■	■	■	■	5/2-way valve, single solenoid • Reverse operation • Pneumatic spring return
O		M52-M	■	■	■	■	5/2-way valve, single solenoid • Reverse operation • mechanical spring return
J		B52	■	■	■	■	5/2-way valve, double solenoid
D		D52	■	■	■	■	5/2-way valve, double solenoid • Dominant signal at port 14 on the control side
SO SQ SS		M52-M	■	–	–	–	5/2-way valve ²⁾ , single solenoid, as plug-in or via pilot valve with pneumatic interface to ISO 15218 See also special valve function in the separate chapter "Solenoid valve with switching position sensing" → page 139
SO SQ SS		M52-M	–	■	–	–	5/2-way valve ²⁾ , single solenoid, as plug-in or via pilot valve with pneumatic interface to ISO 15218 See also special valve function in the separate chapter "Solenoid valve with switching position sensing" → page 139
SP SN		T52-M	–	■	–	–	2x 5/2-way valve, single solenoid, with switching position sensing, pneumatically linked via two ducts as special valve function "control block with safety function" → page 149
B		P53U	■	■	■	■	5/3-way solenoid valve • Mid-position pressurised ¹⁾ • mechanical spring return
G		P53C	■	■	■	■	5/3-way solenoid valve • Mid-position closed ¹⁾ • mechanical spring return
E		P53E	■	■	■	■	5/3-way solenoid valve • Mid-position exhausted ¹⁾ • mechanical spring return

1) If neither solenoid coil is energised, the valve is moved to its mid-position by a mechanical spring. If the two coils are permanently energised one after the other, the valve remains in the switching position of the coil that was activated first
 2) The symbol represents a valve with a proximity switch with a switching output signal, in the illustration an N/O contact. This symbol applies to both N/O and N/C contacts, in accordance with ISO 1219-1. All sensors used here have an N/C contact as the switching element function.

Key features – Pneumatic components

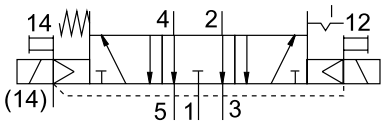
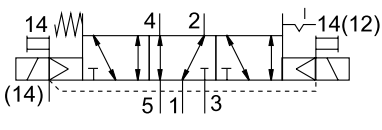
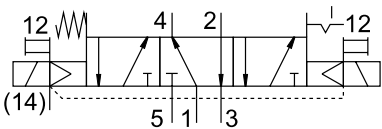
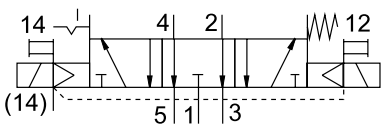
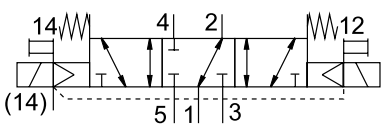
Valve function		Valve code	Width				Description
Terminal code	Circuit symbol		18 mm	26 mm	42 mm	52 mm	
SA		P53ED	■	■	–	–	5/3-way solenoid valve, for special functions as switching position 14 is retained <ul style="list-style-type: none"> • Pressureless switching, self-latching, pneumatic operation • Mid-position exhausted, switching position 14 is retained • mechanical spring return
SB		P53AD	■	■	–	–	5/3-way solenoid valve, for special functions as switching position 14 is retained <ul style="list-style-type: none"> • Holding, blocking a movement (mechanically) • Mid-position port 2 pressurised, port 4 exhausted, switching position 14 is retained • mechanical spring return
SD		P53BD	■	■	–	–	5/3-way solenoid valve, for special functions as switching position 14 is retained <ul style="list-style-type: none"> • Holding, blocking a movement (mechanically) • Mid-position port 4 pressurised, port 2 exhausted, switching position 14 is retained • mechanical spring return
SE		P53EP	■	■	–	–	5/3-way solenoid valve, for special functions as switching position 12 is retained <ul style="list-style-type: none"> • Pressureless switching, self-latching, pneumatic operation • Mid-position exhausted, switching position 12 is retained • mechanical spring return
VG		P53F	–	–	■	■	5/3-way solenoid valve <ul style="list-style-type: none"> • Positioning • Mid-position port 2 pressurised, port 4 closed¹⁾ • mechanical spring return
VB	–	–	–	■	–	–	Vacuum generator with ejector pulse and adjustable air saving function (plate for 2 valve positions, sensor SDE3 with display and M12 connection)
L	–	–	■	■	■	■	For valve terminal only: Cover plate for vacant valve position

1) If neither solenoid coil is energised, the valve is moved to its mid-position by a mechanical spring. If the two coils are permanently energised one after the other, the valve remains in the switching position of the coil that was activated first.

Key features – Pneumatic components

Vertical stacking

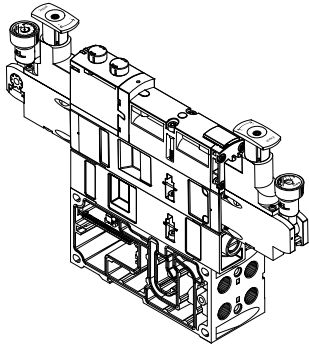

Additional function units can be added to each valve position between the base plate (manifold sub-base) and the valve.

These functions are known as vertical stacking modules and enable special functions or control of an individual valve position. It is possible to link several valve sizes on one valve terminal.

**Note**

Certain combinations are not recommended due to the design of the individual vertical stacking components.

Vertical stacking components

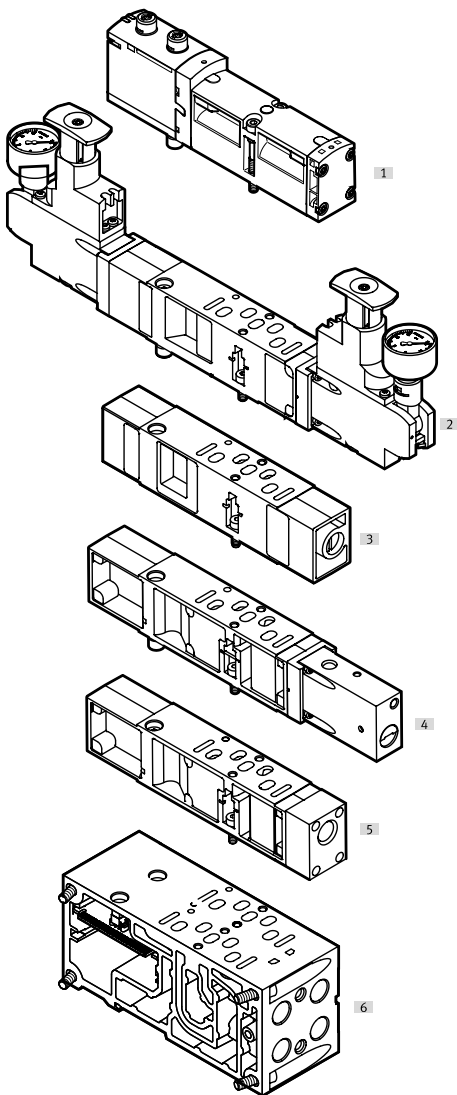

The following component sequence is recommended for valve positions with vertical stacking:

- [1] Valve VSVA
- [2] Pressure regulator plate
- [3] Throttle plate
- [4] Vertical pressure shut-off plate
- [5] Vertical supply plate
- [6] Manifold sub-base

Key features – Pneumatic components

Vertical stacking

Pressure regulator plate

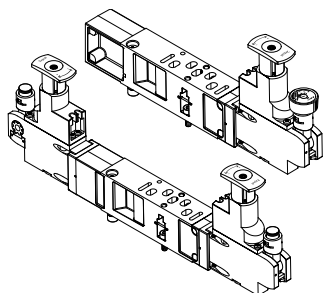

An adjustable pressure regulator can be installed between the base plate (manifold sub-base) and the valve to control the force of the triggered actuator.

This pressure regulator maintains a largely constant output pressure (secondary side) independent of pressure fluctuations (primary side) and air consumption. Also suitable for valves with a symmetrical design.

Standard version:

- Standard port pattern to ISO 15407-2 or ISO 5599-2
- For pressure regulation up to 6 bar or up to 10 bar
- Without pressure gauge (optional)
- Regulator knob with 3 positions (locked, reference position, freely positionable)

Note

With the A, B and AB pressure regulators VABF-S...-1-..., the regulated pressure should not be less than 2 bar.

Use the reversible A, B or AB pressure regulators for regulated pressure of less than 2 bar.

Note

Please note when reordering pressure regulators in sizes 42 mm and 52 mm:
The part number on the regulator plate refers only to the standard version.

When reordering pressure regulators with additional features, such as a lockable rotary knob, extended design etc., only use the VABF configurator.

→ Internet: vabf-s2

Rotary knob for pressure regulator for width 42 mm and 52 mm

Setting the pressure

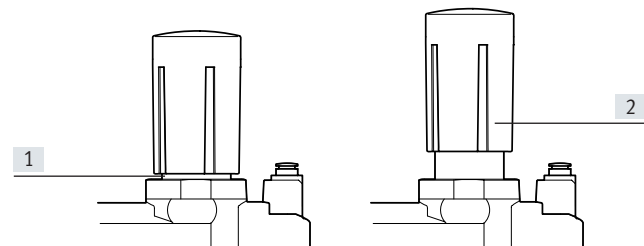

- [1] Pull the rotary knob upward from the locking position [1] into the setting position [2]
- [2] Set the required pressure at the setting position [2] using the rotary knob

- [3] After setting the pressure, push the rotary knob back down to the locking position [1]

Rotary knob for pressure regulator for width 42 mm and 52 mm

Locking the rotary knob

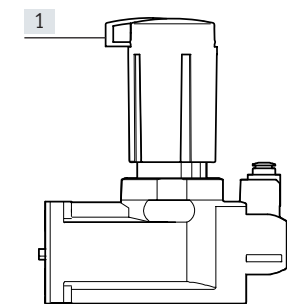

After setting the pressure, the rotary knob can be locked against unauthorised actuation. To do this, the blue locking element is pushed out and secured with a padlock. The rotary knob is now fixed in place and cannot be moved.

Note

The position of the rotary knob using the locking element is determined by the pressure setting. If a number of pressure regulators are installed next to one another, there may not always be enough space to push out the locking elements.

To ensure that the rotary knob can still be locked, it can be pulled off completely, rotated 60° or 120° and pushed back on.

- [1] Locking element, pushed out

Key features – Pneumatic components

Vertical stacking

Energy efficiency through dual-pressure operation or through operation with reversible pressure regulators

Saving energy starts with compressed air generation. It is possible to achieve energy savings of up to 10% per 1 bar drop in pressure. Therefore, wherever possible reduce the pressure to the minimum required.

To save additional energy, you can operate valves in dual-pressure mode in a separate pressure zone.

To do this, the valves used must be operated in reverse mode, i.e. with reversed flow direction (see also information on → page 97). In dual-pressure operation, the valves are then supplied with pressure separately via ducts 3 and 5. The air is exhausted via duct 1.

Requirements for dual-pressure operation:

- Exhaust ducts 3 and 5 in the pressure zone are completely separate.
- Valves are used that can be operated in reverse mode.

Advantages of dual-pressure operation:

It is possible to save energy if a valve can be supplied with different pressures. The advantages are:

- Saves energy because the return stroke can be carried out using reduced force, e.g. 3 bar instead of 6 bar.
- Just one valve is required, as in the case of vacuum application with ejector pulse for example (e.g. duct 3 for vacuum switching, duct 5 for the ejector pulse).
- A reduction in compressed air consumption of up to 50% is possible if two different pressures can be applied to the valve (return stroke uses reduced pressure).

Advantages of reversible operation:

If compressed air is applied to the pressure regulator upstream of the valve (circuit diagram 2), exhausting is directly via the solenoid valve.

This has the following advantages:

- Increased exhaust capacity, exhausting is up to 50% quicker
- Lower wear on the pressure regulator
- Can be adjusted very accurately, perfect for very low operating pressures
- No quick exhaust valves are required.
- Fast cycle times
- The pressure regulator can be adjusted independently of the valve position because operating pressure is permanently present at the pressure regulator.

Dual-pressure operation with standard regulator

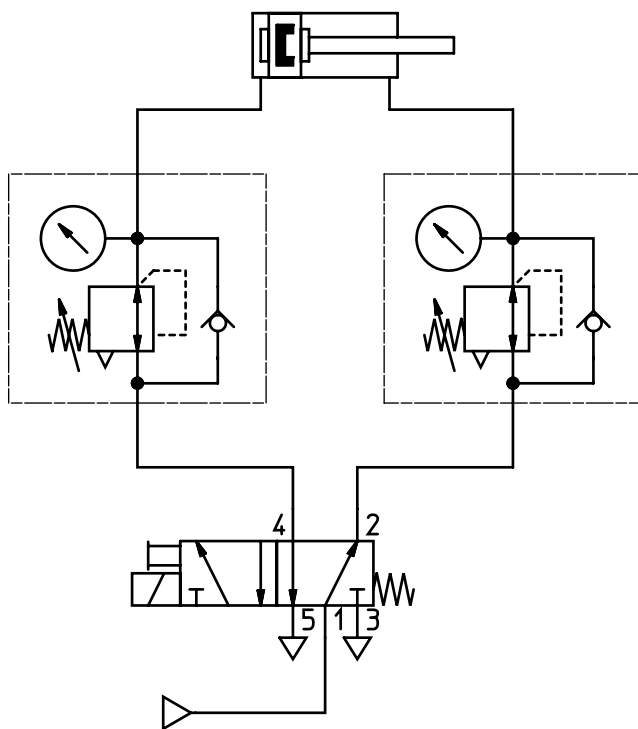

Circuit diagram 1:
Pressure is regulated downstream of the valve

Dual-pressure operation with reversible controller

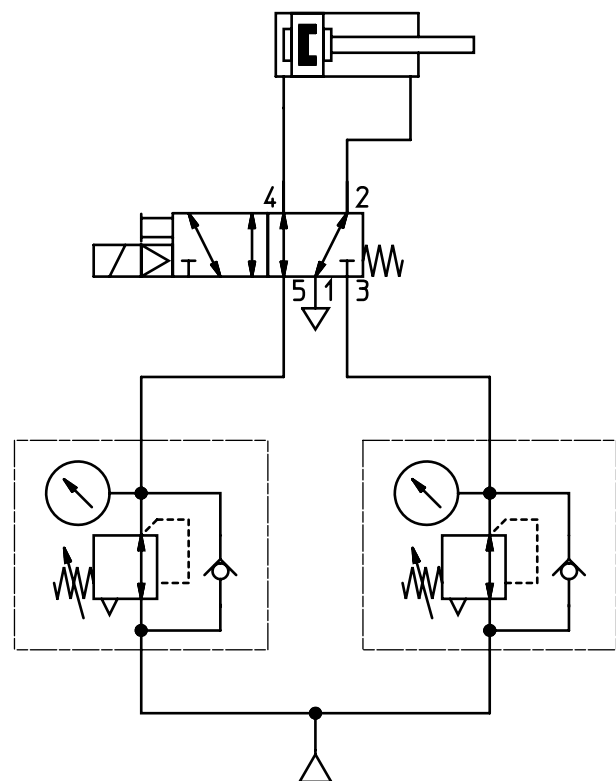

Circuit diagram 2:
Pressure is regulated upstream of the valve

Key features – Pneumatic components

Vertical stacking

Operating mode of the pressure regulator plate (P regulator) for port 1; code: ZA, ZAY, ZF, ZFY

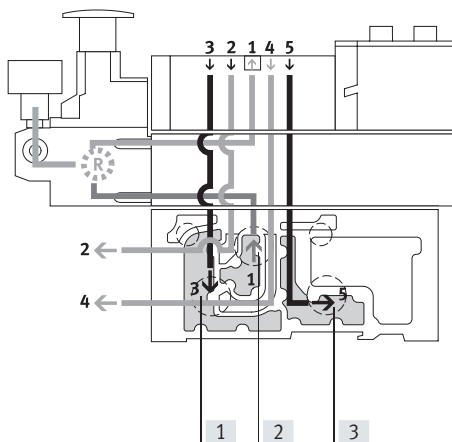

This pressure regulator regulates the pressure upstream of the valve in duct 1. Ducts 2 and 4 thus have the same regulated pressure.

During exhausting, the exhaust flow in the valve is from duct 2 to duct 3 and from duct 4 to duct 5.

- [1] Duct 3 (exhaust air)
- [2] Duct 1 (working air)
- [3] Duct 5 (exhaust air)

Advantages

- The pressure regulator is not affected by exhausting, since the pressure is regulated upstream of the valve.
- The pressure regulator can always be adjusted, since the pressure from the valve terminal is always present.

Application examples

- An equal working pressure is required at working ports 2 and 4.
- A working pressure (e.g. 3 bar) lower than the operating pressure present at the valve terminal (e.g. 8 bar) is required.

Operating mode of the pressure regulator plate (AB regulator) for ports 2 and 4; code: ZD, ZDY, ZI, ZIY

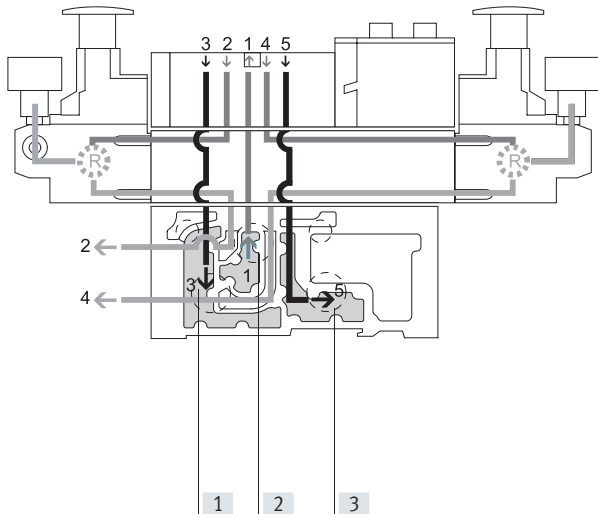

This pressure regulator regulates the pressure in ducts 2 and 4 after the pressure medium flows through the valve. During exhausting, the exhaust flow in the valve is from duct 2 to duct 3 and from duct 4 to duct 5 via the pressure regulator.

Example with the following switching position:

The working air flows from duct 1 of the manifold sub-base via the valve to duct 2, it is then regulated and made available at port 2 of the manifold sub-base. At the same time, exhausting takes place via duct 4 of the manifold sub-base via the regulator and via the valve into duct 5 of the manifold sub-base.

- [1] Duct 3 (exhaust air)
- [2] Duct 1 (working air)
- [3] Duct 5 (exhaust air)

Constraints

The pressure regulator cannot be adjusted in the exhaust position. For example, the pressure regulator for duct 4 cannot be adjusted when the valve is pressurised in the switching position from duct 1 to duct 2 and exhausted from duct 4 to duct 5.

Application examples

Two different working pressures are required at ports 2 and 4 instead of the valve terminal operating pressure

Key features – Pneumatic components

Vertical stacking

Operating mode of the pressure regulator plate (AB regulator, reversible) for ports 2 and 4, reversible; code: ZE, ZEY, ZI, ZIY

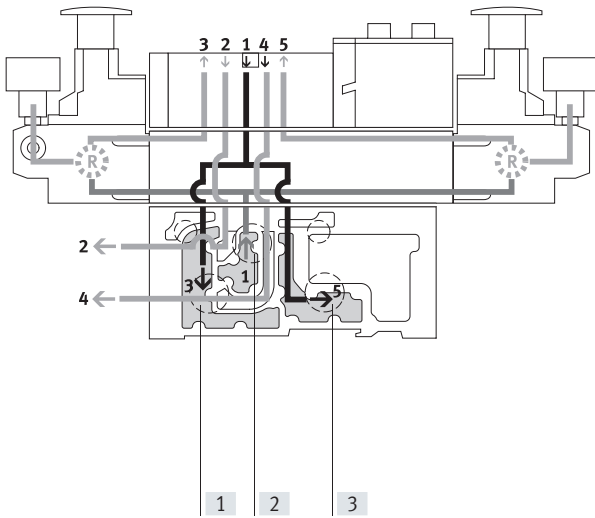

With this pressure regulator, the working air (duct 1) is split and routed directly to both pressure regulators. In each case the regulated working air is present in ducts 3 and 5 on the valve. The valve is thus operated in reverse mode.

This means that:

- Duct 3 routes the working pressure to port 2
- Duct 5 routes the working pressure to port 4

- [1] Duct 3 (exhaust air)
 [2] Duct 1 (working air)
 [3] Duct 5 (exhaust air)

Example with the following switching position:

The working air in duct 1 is split between ducts 3 and 5 in the regulator and flows from here to the valve. The working air in the valve is routed to port 2 of the manifold sub-base. The exhaust air is simultaneously routed via duct 4 of the manifold sub-base and via the valve to regulator duct 1, where it is split between ducts 3 and 5 and then discharged via the manifold sub-base.

Application examples

- Two different pressures are required in ducts 2 and 4 instead of the valve terminal's operating pressure.
- Quick exhausting is required.
- The pressure regulator must always be adjustable.

 **Note**

- Reversible pressure regulator plates should only be combined with valves that can be operated in reverse mode.
- Valves in valve positions with vertical pressure shut-off plates are operated with internal pilot air, even when the valve terminal is operated with external pilot air supply.
- The following combination of reversible valve terminals with vertical stacking components is not permitted:
 - Reversible pressure regulator plates
 - Throttle plates
 - Vertical pressure shut-off plates
 - Vertical supply plates

Advantages

- Fast cycle times
- 50% higher exhaust flow rate, as air is not exhausted via the pressure regulator. The load on the pressure regulator is also reduced.
- No quick exhaust valves are required.
- Operating pressure is always present at the pressure regulator, as the pressure is regulated upstream of the valve, i.e. the regulator can always be adjusted.

Disadvantages

- 2x 3/2-way solenoid valves (code N, K, H) cannot be used, as pressure is present at ports 3 and 5.
- A practical combination with a throttle plate is not possible.

Key features – Pneumatic components

Vertical stacking – Pressure regulator plate, variants 1)									
Code	Type	Width				Pressure regulation up to		Description	
		18 mm	26 mm	42 mm	52 mm	6 bar	10 bar		
Pressure regulator plate for port 1 (P regulator)									
ZA		VABF-S...-R1C2-C-10	■	■	■	■	–	■	Regulates the operating pressure in duct 1 upstream of the solenoid valve
ZAY ²⁾		VABF-S...-R1C2-C-10E	■	■	■	■	–	■	
ZF		VABF-S...-R1C2-C-6	■	■	■	■	■	–	
ZFY ²⁾		VABF-S...-R1C2-C-6E	■	■	■	■	■	–	
Pressure regulator plate for port 2 (B regulator)									
ZC		VABF-S...-R2C2-C-10	■	■	■	■	–	■	Regulates the operating pressure in duct 2 downstream of the solenoid valve
ZCY ²⁾		VABF-S...-R2C2-C-10E	■	■	■	■	–	■	
ZH		VABF-S...-R2C2-C-6	■	■	■	■	■	–	
ZHY ²⁾		VABF-S...-R2C2-C-6E	■	■	■	■	■	–	
Pressure regulator plate for port 4 (A regulator)									
ZB ²⁾		VABF-S...-R3C2-C-10	■	■	■	■	–	■	Regulates the operating pressure in duct 4 downstream of the solenoid valve
ZG ²⁾		VABF-S...-R3C2-C-6	■	■	■	■	■	–	
Pressure regulator plate for ports 2 and 4 (AB regulator)									
ZD		VABF-S...-R4C2-C-10	■	■	■	■	–	■	Regulates the working pressure in ducts 2 and 4 downstream of the solenoid valve
ZDY ²⁾		VABF-S...-R4C2-C-10E	■	■	■	■	–	■	
ZI		VABF-S...-R4C2-C-6	■	■	■	■	■	–	Note These pressure regulator plates cannot be combined with reversible 2x 3/2-way solenoid valves (code P, Q, R).
ZIY ²⁾		VABF-S...-R4C2-C-6E	■	■	■	■	■	–	

1) Width variants 42 mm and 52 mm (ISO 5599-2, ISO 1 and ISO 2) can be selected via the pressure regulator configurator VABF-S2

2) Also suitable for valves with a symmetrical design

Valve terminal VTSA/VTSA-F, NPT

Key features – Pneumatic components

Vertical stacking – Pressure regulator plate, reversible, variants 1)									
Code	Type	Width				Pressure regulation up to		Description	
		18 mm	26 mm	42 mm	52 mm	6 bar	10 bar		
Pressure regulator plate for port 2, reversible (B regulator)									
ZL		VABF-S...-R6C2-C-10	■	■	■	■	–	■	Reversible pressure regulator for port 2
ZLY ²⁾		VABF-S...-R6C2-C-10E	■	■	■	■	–	■	
ZN		VABF-S...-R6C2-C-6	■	■	■	■	■	–	
ZNY ²⁾		VABF-S...-R6C2-C-6E	■	■	■	■	■	–	
Pressure regulator plate for port 4, reversible (A regulator)									
ZK ²⁾		VABF-S...-R7C2-C-10	■	■	■	■	–	■	Reversible pressure regulator for port 4
ZM ²⁾		VABF-S...-R7C2-C-6	■	■	■	■	■	–	
Pressure regulator plate for ports 2 and 4, reversible (AB regulator)									
ZE		VABF-S...-R5C2-C-10	■	■	■	■	–	■	<ul style="list-style-type: none"> • Reversible pressure regulator for ports 2 and 4 • Pressure regulation upstream of the solenoid valve • Routes the operating pressure from duct 1 to ducts 3 and 5 • Routes the exhaust air from duct 1 to ducts 3 and 5 <p>Note</p> <p>These pressure regulator plates cannot be combined with standard 2x 3/2-way solenoid valves (code N, K, H).</p> <p>Reversible 2x 3/2-way solenoid valves (code P, Q, R) must not be operated in a separate pressure zone in combination with these pressure regulators.</p>
ZEV ²⁾		VABF-S...-R5C2-C-10E	■	■	■	■	–	■	
ZJ		VABF-S...-R5C2-C-6	■	■	■	■	■	–	
ZJY ²⁾		VABF-S...-R5C2-C-6E	■	■	■	■	■	–	

1) Width variants 42 mm and 52 mm (ISO 5599-2, ISO 1 and ISO 2) can be selected via the pressure regulator configurator VABF-S2

2) Also suitable for valves with a symmetrical design

Key features – Pneumatic components

Vertical stacking

Throttle plate

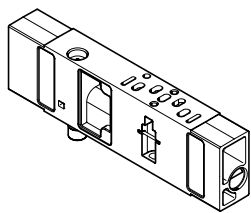

The throttle plate has two flow control valves on which the exhaust air flow rate at exhaust ports 3 or 5 can be adjusted.

This enables the movement of the drive to be initiated and the required speed to be set on the valve terminal using the manual override. Ducts 3 and 5 can be adjusted independently of each other.



Note

On reversible valve terminals, the working air is controlled in ducts 3 and 5 upstream of the valve.

Code	Type	Width				Description
		18 mm	26 mm	42 mm	52 mm	
X	VABF-S4-...F1B1-C	■	■	■	■	<ul style="list-style-type: none"> Restricts the exhaust air downstream of the valve in ducts 3 and 5

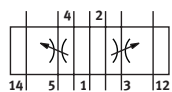

Vertical pressure shut-off plate

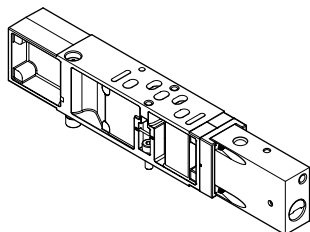

This is equipped with a switch with which the compressed air supply can be shut off. A solenoid valve or downstream vertical stacking plate can thus be replaced without switching off the overall air supply. If the control chain has a redundant connection, the cycle can continue even in the case of a cyclical control system.

After the shut-off function has been activated, the exhaust air/return air is discharged from the activated valve. This is done via an M5 threaded connection or via duct 3 in the case of width 18 and 26 mm, and via duct 3 in the case of width 42 and 52 mm.



Note

The operating pressure of the valve terminal must lie within the range of the required pilot pressure (i.e. min. 3 bar). When using the end plate with pilot air selector, only the switching position with code W and U can be used.

Code	Type	Width				Description
		18 mm	26 mm	42 mm	52 mm	
ZT	VABF-S4...L1D1-C	■	■	–	–	<ul style="list-style-type: none"> 3/2-way valve for shutting off the operating pressure at the valve position Blocks ducts 1 and 14 for the valve position Supplies the valve position with internal pilot air Pressure separation on the valve assembly
	VABF-S2...L1D1-C	–	–	■	■	
ZS	VABF-S...L1D2-C	■	■	–	–	<ul style="list-style-type: none"> 3/2-way valve for shutting off the operating pressure at the valve position Blocks ducts 1 and 14 for the valve position Supplies the valve position with internal pilot air Pressure separation can be shut off on the valve assembly using a key



Note

The vertical pressure shut-off plates VABF-... are provided only in combination with solenoid valves VSVA-...T1L from Festo. In the vertical pressure shut-off plate only ducts 1 and 14, and not duct 12, are blocked.

Key features – Pneumatic components

Vertical supply plate

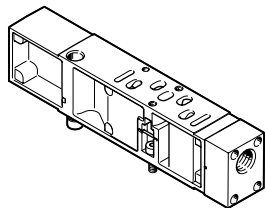

This plate enables a valve to be supplied with individual operating pressure independently of the operating pressure of the valve terminal.

As additional compressed air supply for a valve. To supply an additional pressure zone.

Code	Diagram	Type	Width				Description
			26 mm	18 mm	42 mm	52 mm	
ZU		VABF-S-...P1A3-...	■	■	■	■	Plate with port 11 for supplying individual operating pressure to a valve position, duct 1
ZV		VABF-S-...P1A14C	■	■	■	■	Plate with port 11 for supplying individual operating pressure to a valve position, ducts 1 and 14

Key features – Pneumatic components

Compressed air supply and exhausting

Right end plate, internal pilot air supply

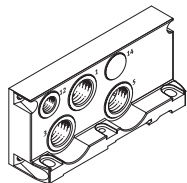

- Code V
- (no port 14)

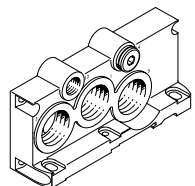

- Code V1, V3
- (port 14 is sealed with a blanking plug)

Right end plate, external pilot air supply

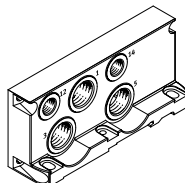

- Code X

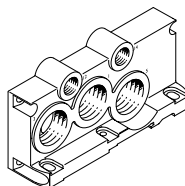

- Code X1, X3

Right end plate with pilot air selector

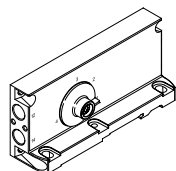

- Code Z, Y, W, U
- Code Z: selector position 1, external pilot air supply
- Code Y: selector position 2, internal pilot air supply

- Code W: selector position 3, external pilot air supply (ducted)

- Code U: selector position 4, internal pilot air supply (ducted)

The valve terminal VTSA/VTSA-F can be supplied with compressed air at one or more points. This is a reliable way of ensuring that all functional components will always offer good performance, even with large-scale extensions.

The valve terminal is generally supplied via supply plates (max. 16 per valve terminal) and/or via the right end plate.

Exhausting is either via silencers or ports for ducted exhaust air on the supply plates and/or on the right end plate.

Supply plates, exhaust port 3/5 separated

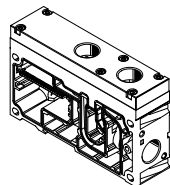

- Code K

Supply plates, exhaust port 3/5 common

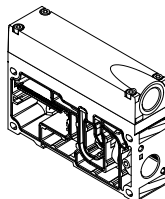

- Code L

Key features – Pneumatic components

Additional compressed air supply/duct separation

Additional supply plates can be used to ensure the compressed air supply for larger valve terminals or to create additional pressure zones.

These can be selected at any point upstream or downstream of the manifold sub-bases.

Supply plates contain the ports:

- Compressed air supply (1)
- Exhaust port (3/5) common or separate

Depending on your order, the exhaust ducts are either ducted or exhausted via silencers.

VTSA/VTSA-F with ducted exhaust air:

When the exhaust air is ducted, exhausting can take place via a supply plate or a right end plate (code V or X).

If duct separation is required, there are three different options:

- Duct separation 1, 3, 5: code S
- Duct separation 1: code T
- Duct separation 3, 5: code R

If a combination of duct separation (S, T or R) and one or two supply plates is required, the following variants can be selected:

- Supply plate with duct separation on the left: code SU, TU, RU
- Supply plate with duct separation on the right: code US, UT, UR
- 2 supply plates with intermediate duct separation: code USU, UTU, URU.

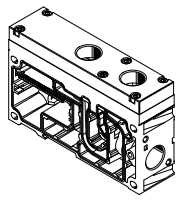
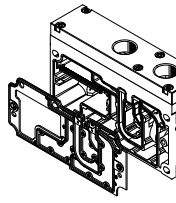
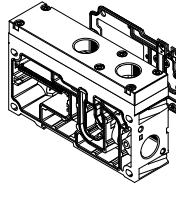
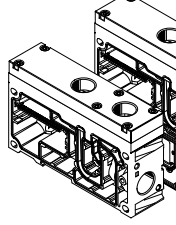
Supply plates		Type	Width				Description
Code			18 mm	26 mm	42 mm	52 mm	
U		<ul style="list-style-type: none"> • Exhaust port 3/5 common VABF-S6-1-P1A7-N12 • Exhaust port 3/5 separate VABF-S6-1-P1A6-N12 	■	■	■	■	Supply plate without duct separation (no R, S or T selected)
SU TU RU			■	■	■	■	Supply plate with duct separation on the left, if R, S or T is selected
US UT UR			■	■	■	■	Supply plate with duct separation on the right, if R, S or T is selected
USU UTU URU			■	■	■	■	2 supply plates with duct separation in centre, if R, S or T selected

Key features – Pneumatic components

Right end plate

Right end plates with different port sizes are available depending on the flow rate required.

With the following right end plates, the outlet direction of the ports is aligned with the horizontal stacking direction. Right end plates with pilot air supply/pilot exhaust air

- Internal pilot air supply: code V, V1, V2 and V3 (ducts 1 and 14 are connected)
- External pilot air supply: code X, X1 and X3, as well as XP1, XP2, XP3 and XS

For end plates with pilot air selector, the outlet direction of the ports is to the front of the valve terminal. This means that all the ports on the valve terminal can be combined in one outlet direction.

The special feature of the end plates with pilot air selector is the selector switch itself, which has four settings for different pilot air supply/pilot exhaust air.

End plates with pilot air selector switch set at the factory for:

- External pilot air supply: selector position 1 (code Z)
- Internal pilot air supply: selector position 2 (code Y)
- External pilot air supply, ducted pilot exhaust air: selector position 3 (code W)
- Internal pilot air supply, ducted pilot exhaust air: selector position 4 (code U)



Note

- The end plate with pilot air selector must be used in combination with a supply plate.
- The reversible 3/2-way solenoid valves (code P, Q, R) must only be operated in selector position 1 or 2.
- Ducted pilot exhaust air via port 12 is only possible with rotated seals on the valve.

Right end plate, variants

Code	Blanking plug in duct	Pilot air supply	Ducted pilot exhaust air ¹⁾ Position of the seal on the solenoid valve ("ISO")	Connecting thread	
				1, 3, 5	12, 14
V	–	Internal	–	1/2 NPT	1/4 NPT
V1	14		–	3/4 NPT	1/4 NPT
V3	14		■	3/4 NPT	1/4 NPT
X	–	External	–	1/2 NPT	1/4 NPT
X1	–		–	3/4 NPT	1/4 NPT
X3	–		■	3/4 NPT	1/4 NPT
XP1 ²⁾	1	External, via soft-start valve ("gradual pressure build-up")	–	1/2 NPT	1/4 NPT
XP2 ³⁾	1, 14		–	1/2 NPT	1/4 NPT
XP3 ³⁾	1, 3, 5, 14		–	1/2 NPT	1/4 NPT
XS ⁴⁾	14	External, via pilot air switching valve ("switchable pilot air")	–	1/2 NPT	1/4 NPT

1) Pilot exhaust air is ducted on the end plate via port 12 and exhausted (done by turning the seal on the solenoid valve to position "ISO")

2) Not possible in combination with soft-start valve code PQ, PP, PO (with internal pilot air supply)

3) Not possible in combination with soft-start valve code PN, PM, PK (with external pilot air supply)

4) Only possible in combination with pilot air switching valve code SS with intermediate plate code Z0

Right end plate with pilot air selector

Code	Pilot air supply	Selector position	Ducted pilot exhaust air ¹⁾ Position of the seal on the solenoid valve ("ISO")	Connecting thread 12, 14
Z	External	1	–	1/4 NPT
Y	Internal	2	–	1/4 NPT
W	External (ducted)	3	■	1/4 NPT
U	Internal (ducted)	4	■	1/4 NPT

1) Pilot exhaust air is ducted on the end plate via port 12 and exhausted (done by turning the seal on the solenoid valve to position "ISO")

Key features – Pneumatic components

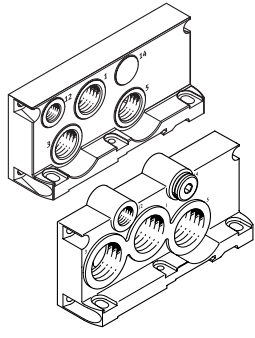
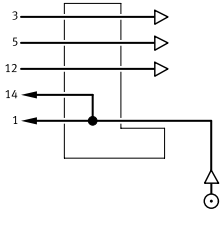
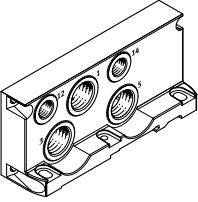
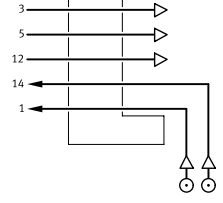
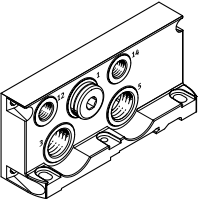
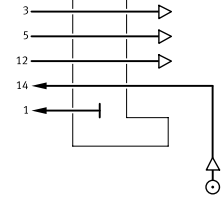
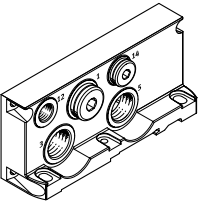
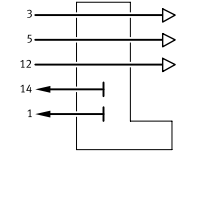
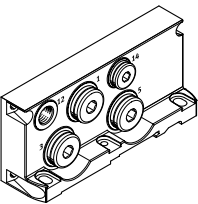
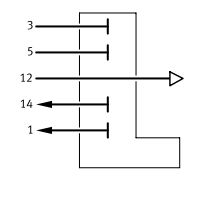
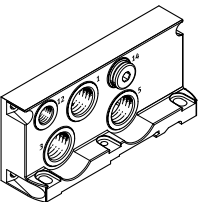
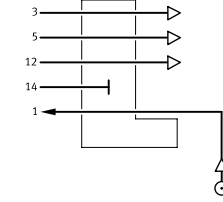
Right end plate			
Code	Type of compressed air supply and pilot air supply	Description	
Right end plate (graphical representation)			
V V1 V3			Internal pilot air supply <ul style="list-style-type: none"> • Pilot air supply is branched internally from port 1 • Port 14 is not available with code V • Port 14 is sealed with a blanking plug for code V1, V3 • Exhaust air via ports 3 and 5 • For operating pressure in the range 3 ... 10 bar • Pilot exhaust air via port 12¹⁾ • V1 cannot be selected in combination with a soft-start valve in the last pressure zone
X X1 X3			External pilot air supply <ul style="list-style-type: none"> • Pilot air supply between 2 and 10 bar is connected at port 14 • Exhaust air via ports 3 and 5 • For operating pressure in the range -0.9 ... 10 bar (suitable for vacuum) • Pilot exhaust air via port 12¹⁾ • X1 cannot be selected in combination with a soft-start valve in the last pressure zone
XP1			External pilot air supply, compressed air supply via soft-start valve 2) <ul style="list-style-type: none"> • Port 1 is sealed with a blanking plug • Exhaust air via ports 3 and 5 • Pilot exhaust air via port 12¹⁾
XP2			External pilot air supply, compressed air supply via soft-start valve 2) <ul style="list-style-type: none"> • Internal pilot air supply 14 via soft-start valve • Ports 1 and 14 are sealed • Exhaust air via ports 3 and 5 • Pilot exhaust air via port 12¹⁾
XP3			External pilot air supply, compressed air supply via soft-start valve 2) <ul style="list-style-type: none"> • Internal pilot air supply 14 via soft-start valve • Ports 1, 3, 5 and 14 are sealed • Pilot exhaust air via port 12¹⁾
XS			External pilot air supply via pilot air switching valve 3) <ul style="list-style-type: none"> • Internal pilot air supply 14 via pilot air switching valve • Port 14 is sealed • Exhaust air via ports 3 and 5 • Pilot exhaust air via port 12¹⁾

1) Ducted pilot exhaust air is only possible with rotated seals on the valve

2) Application with XP1, XP2, XP3 and soft-start valve in combination with valves of width 52 mm: please note the maximum flow rate of the soft-start valve in this pressure zone

3) Application with XS and pilot air switching valve in combination with intermediate plate

Key features – Pneumatic components

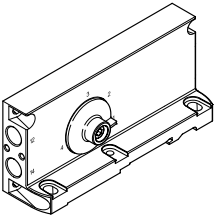
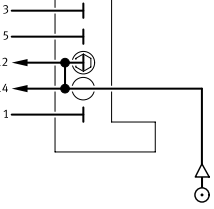
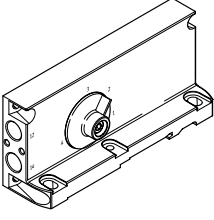
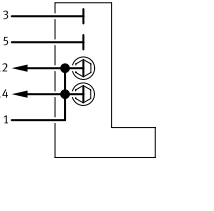
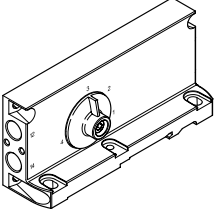
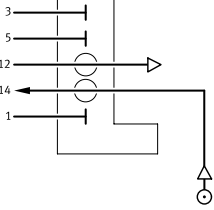
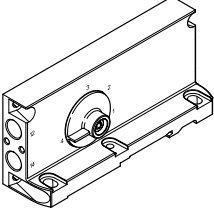
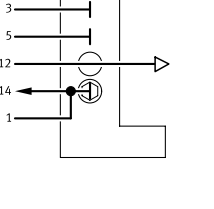
Right end plate		
Code ¹⁾	Type of compressed air supply and pilot air supply	Description
End plate with pilot air selector		
Z (1)	 	<p>External pilot air supply</p> <ul style="list-style-type: none"> • Pilot air supply is connected at port 14 • Port 12 is sealed with a blanking plug • Ports 12 and 14 are internally connected • Pilot exhaust air unducted via valve housing
Y (2)	 	<p>Internal pilot air supply</p> <ul style="list-style-type: none"> • Pilot air supply is branched internally from port 1 • Ports 1, 12 and 14 are internally connected • Ports 12 and 14 are sealed with blanking plugs • Pilot exhaust air unducted via valve housing
W (3)	 	<p>External pilot air supply, ducted pilot exhaust air</p> <ul style="list-style-type: none"> • Pilot air supply is connected at port 14 • Pilot exhaust air via port 12 ²⁾ • Cannot be selected in combination with a soft-start valve in the last pressure zone
U (4)	 	<p>Internal pilot air supply, ducted pilot exhaust air</p> <ul style="list-style-type: none"> • Pilot air supply is branched internally from port 1 • Ports 1 and 14 are internally connected • Port 14 is sealed with a blanking plug • Pilot exhaust air via port 12 ²⁾ • Cannot be selected in combination with a soft-start valve in the last pressure zone

1) Selector setting in brackets

2) Ducted pilot exhaust air is only possible with rotated seals on the valve (pilot exhaust air 82/84 including venting air for valves)

 - Note

The reversible 3/2-way solenoid valves (code P, Q, R) must only be operated in selector position 1 or 2.

Key features – Pneumatic components

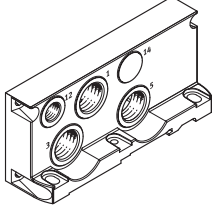
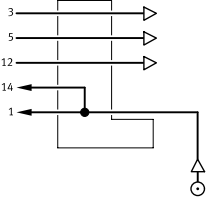
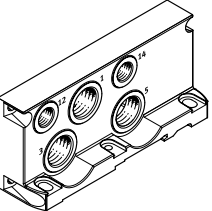
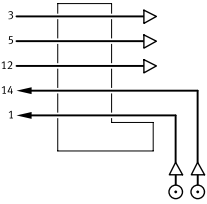
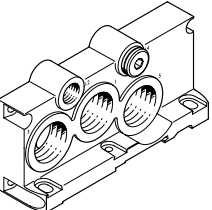
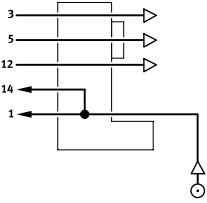
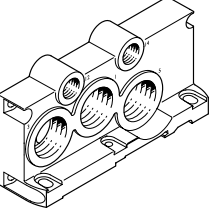
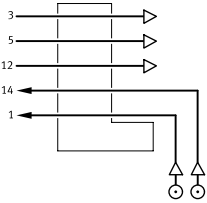
Configuration of all pneumatic connections with NPT thread						
Code			Connection (duct)	Designation	Code M Push-in connector, large	Code N Push-in connector, small
Right end plate						
V			1	Push-in fitting	QS-1/2-5/8-U	QB-1/2-1/2-U
			3 and 5	Silencer or Push-in fitting	U-1/2-B-NPT or QS-1/2-5/8-U	U-1/2-B-NPT or QB-1/2-1/2-U
			12	Silencer or Push-in fitting	U-1/4-B-NPT or QB-1/4-3/8-U	U-1/4-B-NPT or QB-1/4-5/16-U
X			1	Push-in fitting	QS-1/2-5/8-U	QB-1/2-1/2-U
			3 and 5	Silencer or Push-in fitting	U-1/2-B-NPT or QS-1/2-5/8-U	U-1/2-B-NPT or QB-1/2-1/2-U
			12	Silencer or Push-in fitting	U-1/4-B-NPT or QB-1/4-3/8-U	U-1/4-B-NPT or QB-1/4-5/16-U
V1 V3			1	Barbed hose fitting	N-3/4-P-19-NPT ¹⁾	–
			3 and 5	Silencer or Barbed hose fitting	U-3/4-B-NPT ¹⁾ or N-3/4-P-19-NPT ¹⁾	–
			12	Silencer or Push-in fitting	U-1/4-B-NPT or QB-1/4-1/2-U	U-1/4-B-NPT or QB-1/4-3/8-U
X1 X3			1	Barbed hose fitting	N-3/4-P-19-NPT ¹⁾	–
			3 and 5	Silencer or Barbed hose fitting	U-3/4-B-NPT or N-3/4-P-19-NPT ¹⁾	–
			12	Silencer or Push-in fitting	U-1/4-B-NPT or QB-1/4-1/2-U	U-1/4-B-NPT or QB-1/4-3/8-U
14	Push-in fitting	QB-1/4-1/2-U	QB-1/4-3/8-U			

1) For tubing with I.D. 19 mm. Use tubing clips to DIN 3017

Key features – Pneumatic components

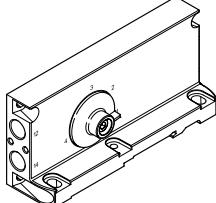
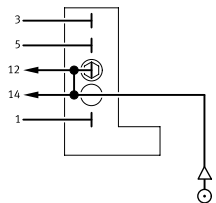
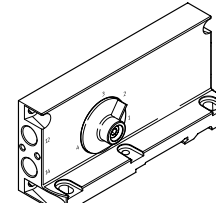
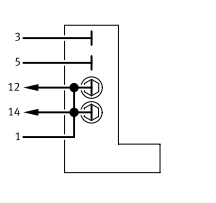
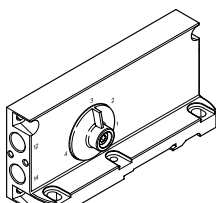
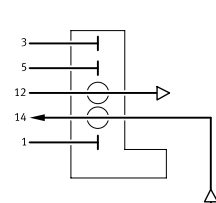
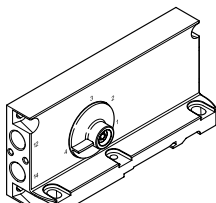
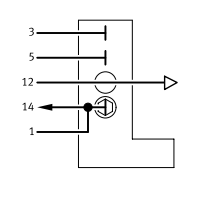
Configuration of all pneumatic connections with NPT thread						
Code ¹⁾			Connection	Designation	Code M Push-in connector, large	Code N Push-in connector, small
End plate with pilot air selector						
Z (1)			12	Blanking plug	B-1/4-NPT	B-1/4-NPT
			14	Push-in fitting	QB-1/4-3/8-U	QB-1/4-5/16-U
Y (2)			12	Blanking plug	B-1/4-NPT	B-1/4-NPT
			14	Blanking plug	B-1/4-NPT	B-1/4-NPT
W (3)			12	Silencer or Push-in fitting	U-1/4-B-NPT or QB-1/4-3/8-U	U-1/4-B-NPT or QB-1/4-5/16-U
			14	Push-in fitting	QB-1/4-3/8-U	QB-1/4-5/16-U
U (4)			12	Silencer or Push-in fitting	U-1/4-B-NPT or QB-1/4-3/8-U	U-1/4-B-NPT or QB-1/4-5/16-U
			14	Blanking plug	B-1/4-NPT	B-1/4-NPT

1) Selector setting in brackets

Key features – Pneumatic components

Using the seals with ducted/unducted pilot exhaust air

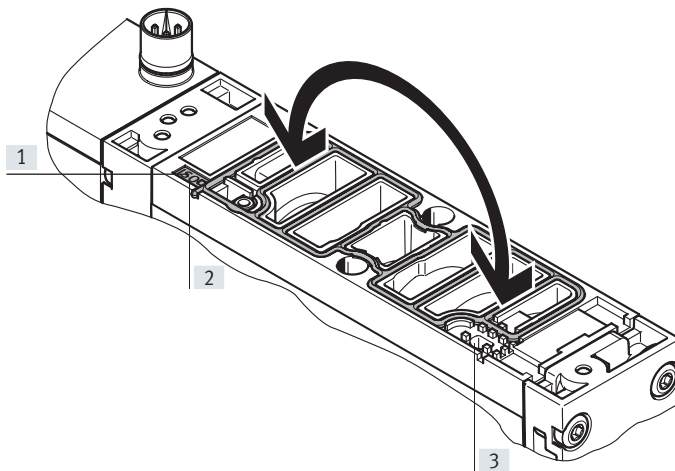

Unducted pilot exhaust air:

- The seal is visible in the display window on control side 14.
- The "ISO" mark is visible on the inscription label on the seal surface.

Ducted pilot exhaust air:

- The seal is visible in the display window on control side 12.
- The "ISO" mark is visible on the inscription label on the seal surface.

- [1] Inscription label
 [2] Display window on control side 14 ("ISO" is visible)
 [3] Display window on control side 12 ("ISO" is visible)

Pilot air supply

The port for the pneumatic supply is located on the supply plates or the right end plate.

The ports differ for the following types of pilot air supply:

- Internal
- External

- Note

If a gradual pressure build-up is required in the system by using a soft-start valve, then external pilot air should be selected so that the pilot pressure is already applied in full at the point of switch-on.

Internal pilot air supply

Internal pilot air supply can be selected if the working pressure is between 3 and 10 bar.

In this case the pilot air supply is branched from the compressed air supply 1 using an internal connection. Port 14 is not available with code V and is sealed with a blanking plug for code V1, V3.

External pilot air supply

If the supply pressure is less than 3 bar, you must operate your valve terminal VTSA/VTSA-F using external pilot air supply.

The pilot air supply is then supplied via port 14 on the right end plate. This is the case even if the valve terminal is operated with different pressure zones.

Key features – Pneumatic components

Creating pressure zones and separating exhaust air

The valve terminal VTSA/VTSA-F offers a number of options for creating pressure zones if different working pressures are required.

Pressure zones are created by isolating the internal supply ducts between the manifold sub-bases by appropriate duct separation.

Compressed air is supplied and exhausted via a supply plate. The position of the supply plates and duct separations can be freely selected for VTSA/VTSA-F.

Duct separations are integrated exhausts as per your order. Duct separations can be distinguished by their coding, even when the valve terminal is assembled.

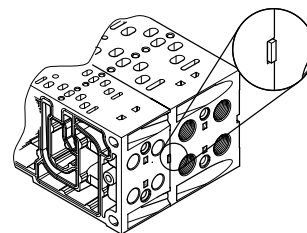

Creating pressure zones

Code	Separating seal		Basic representation	Width				Description
	Illustrated examples	Coding		18 mm	26 mm	42 mm	52 mm	
T				■	■	■	■	Duct 1 separated
S				■	■	■	■	Ducts 1, 3 and 5 separate
R				■	■	■	■	Ducts 3 and 5 separate
TL		Colour-coded in red		■	■	■	■	Duct 1 and 14 separated
K		Colour-coded in green		■	■	■	■	Ducts 1, 3, 5 and 14 separate
L		Colour-coded in white		■	■	■	■	Duct 14 separated

Key features – Pneumatic components

Example: Compressed air supply and pilot air supply, right end plate

Internal pilot air supply, silencer/ducted exhaust air

Right end plate: code V and V1

Optional duct separation

The adjacent diagram shows an example of the configuration and connection of the compressed air supply with internal pilot air supply:

- Port 14 is not available with code V and is sealed with a blanking plug for code V1.
- The air is exhausted via the silencer at exhaust port 3/5.
- Duct separations can optionally be used to create pressure zones.

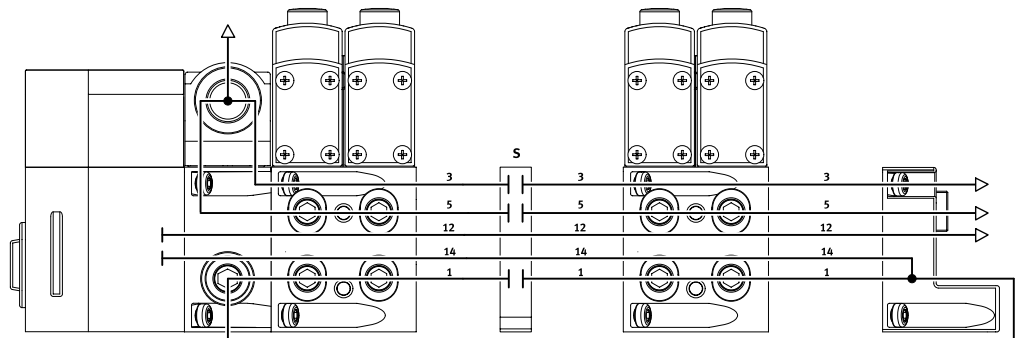
**Example: Compressed air supply and pilot air supply, right end plate**

External pilot air supply, silencer/ducted exhaust air

Right end plate: code X and X1

Optional duct separation

The adjacent diagram shows an example of the configuration and connection of the compressed air supply with external pilot air supply:

- Port 14 on the right end plate is equipped with a fitting for this.
- The air is exhausted via the silencer at exhaust port 3/5.
- Duct separations can optionally be used to create pressure zones.

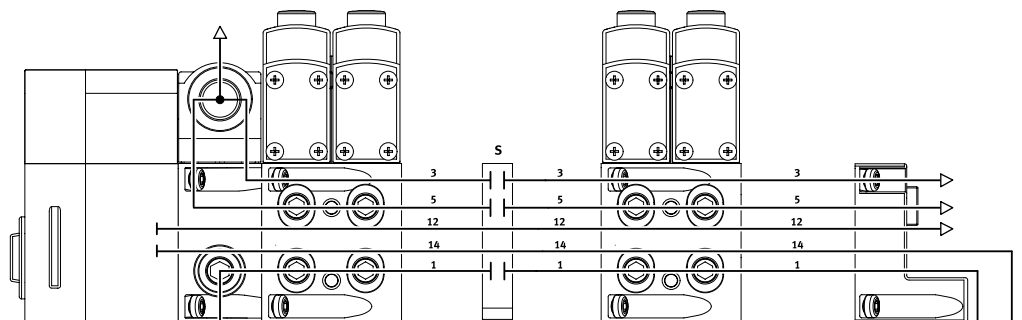

Key features – Pneumatic components – Compressed air supply and pressure zones, examples

Example: Compressed air supply and pilot air supply via end plate with pilot air selector

Internal pilot air supply, ducted exhaust air/silencer

Right end plate: code U

Optional duct separation

The adjacent diagram shows an example of the configuration and connection of the compressed air supply with internal pilot air supply:

- Port 14 on the right end plate is tightly sealed.
- The air is ducted or discharged via the silencer at exhaust port 3/5.
- The selector switch on the pilot air selector is in position 4.
- Duct separations can optionally be used to create pressure zones.

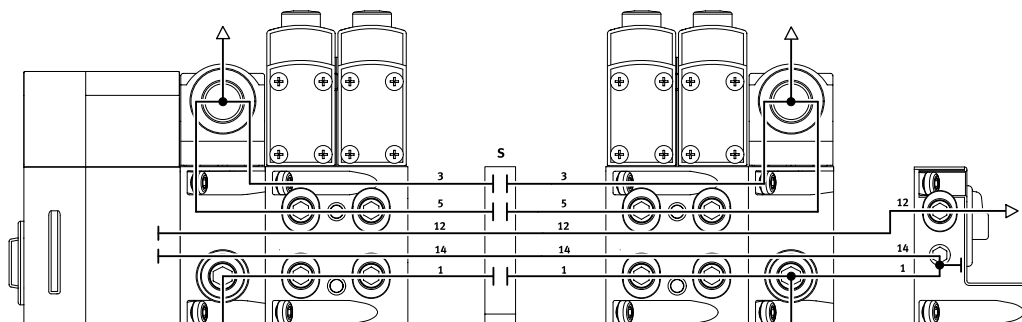

Example: Compressed air supply and pilot air supply via end plate with pilot air selector

External pilot air supply, ducted exhaust air/silencer

Right end plate: code Z

Optional duct separation

The adjacent diagram shows an example of the configuration and connection of the compressed air supply with external pilot air supply:

- Port 14 on the right end plate is equipped with a fitting for this.
- Port 12 is sealed with a blanking plug since it is internally connected with port 14.
- The air is ducted or discharged via the silencer at exhaust port 3/5.
- The selector switch on the pilot air selector is in position 1.
- Duct separations can optionally be used to create pressure zones.

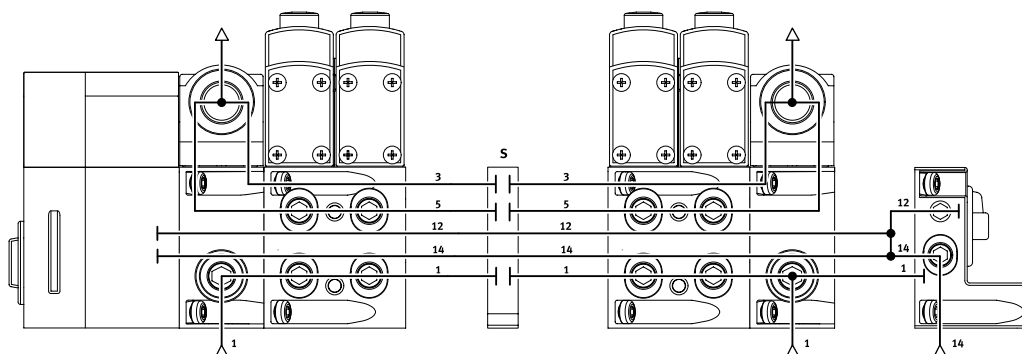



Key features – Pneumatic components – Compressed air supply and pressure zones, examples

Examples: Creating pressure zones

VTSA/VTSA-F with CPX terminal

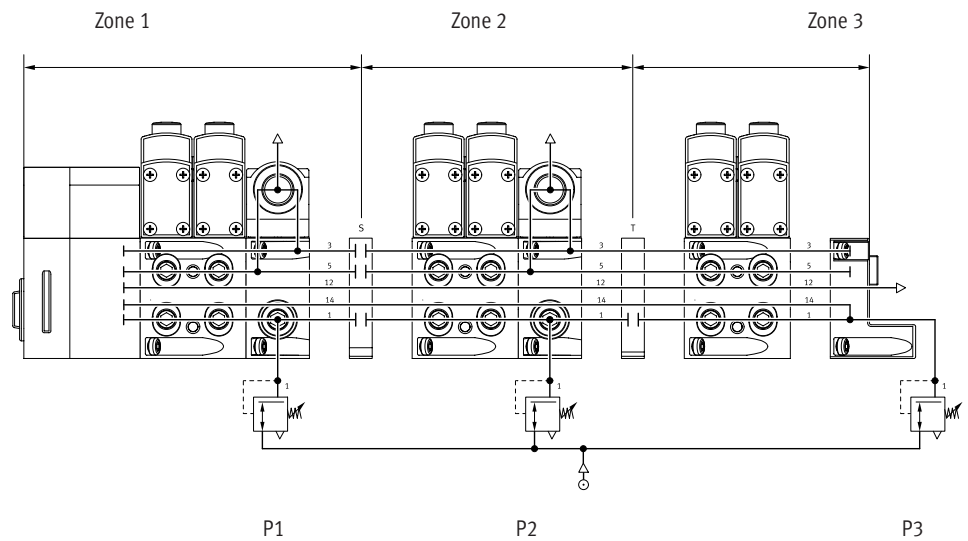
With the VTSA/VTSA-F, up to 16 pressure zones can be created (up to 32 pressure zones if only size 1, ISO 5599-2, is fitted). The diagram shows an example of the configuration and connection of three pressure zones using duct separations – with internal pilot air supply.



 **Note**

Examples with pressure zones and soft-start valve are described separately in the chapter "Soft-start valve"

→ page 168.

Key features – Mounting

Valve terminal mounting

Sturdy valve terminal mounting thanks to:

- Through-holes for wall mounting
- Additional mounting brackets
- DIN rail mounting for VTSA/VTSA-F (horizontal mounting position permitted)

 **Note**

Further information on mounting the valve terminal, according to the valve terminal configuration, can be found online.

Wall mounting, general

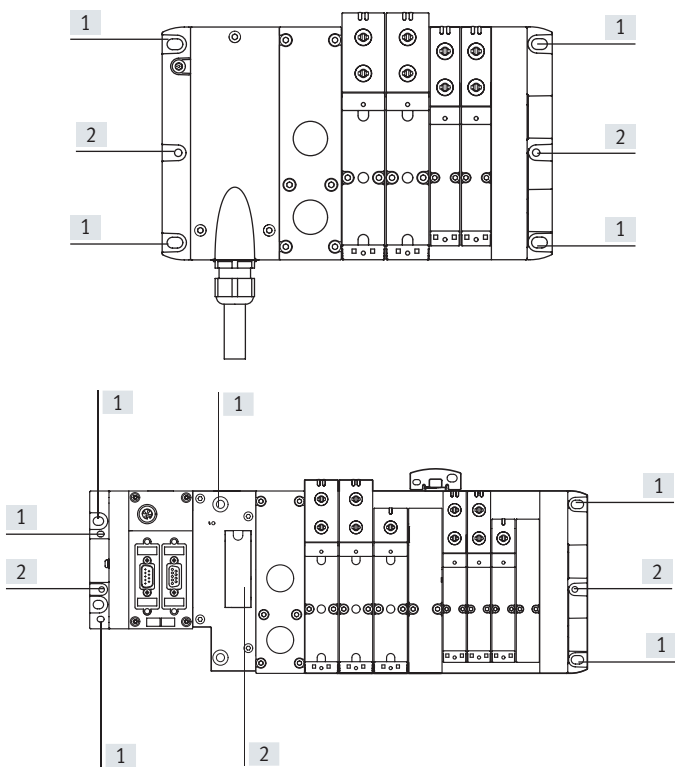

- [1] Drilled hole for M6 screw
- [2] Drilled hole for DIN rail mounting

The valve terminal VTSA/VTSA-F is screwed onto the mounting surface using M6 screws. The mounting holes are located at the following points:

- Multi-pin plug
 - 2 each on the multi-pin connection block and the right end plate
- Fieldbus, CPX:
 - 2 each on the left (CPX) and right (VTSA/VTSA-F) end plate and the pneumatic interface
- I-Port/IO-Link® (4 pieces); 2 each on the I-Port/IO-Link® interface and on the right end plate

Mounting brackets can be mounted on pneumatic supply plates and manifold sub-bases. If using CPX components, see:

→ Internet: cpx

 **Note**

Wall mounting of the VTSA/VTSA-F with more than five pneumatic modules

Note the following instructions:

- Additionally use mounting brackets of the type VAME-S6-W-M46
- Mount these on each fourth plate (manifold sub-base, supply plate or exhaust plate), counting from left to right, starting after the pneumatic interface.
- No mounting bracket is required next to the right end plate.
- Always use the pre-assembled mounting brackets when mounting factory pre-assembled valve terminals on a wall.

Wall mounting with CPX polymer design

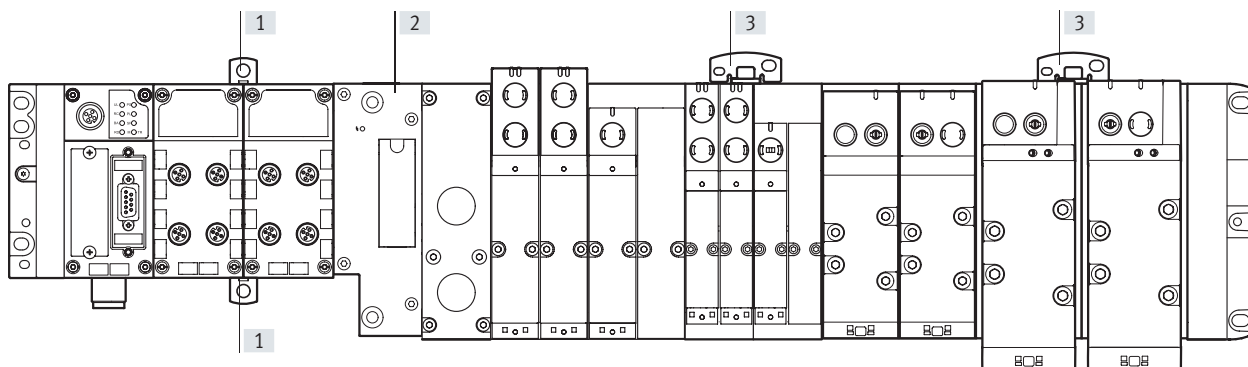

[1] Additional wall mounting for polymer CPX terminal

[2] Pneumatic interface

[3] Additional wall mounting for VTSA/VTSA-F

(with drilled hole for M5 and M6 screw)

In the case of polymer CPX terminals with 4 and more interlinking blocks, additional wall mountings of the type CPX-BG RW must be used every 100 ...150 mm. These mountings are clipped in at the top and bottom between the CPX modules.

In the case of the VTSA/VTSA-F, mounting brackets must be mounted on the wall as instructed above.

Brackets of the type VAME-S6-W-M46 must be used as an additional wall mounting.

Key features – Mounting

Wall mounting with CPX metal design

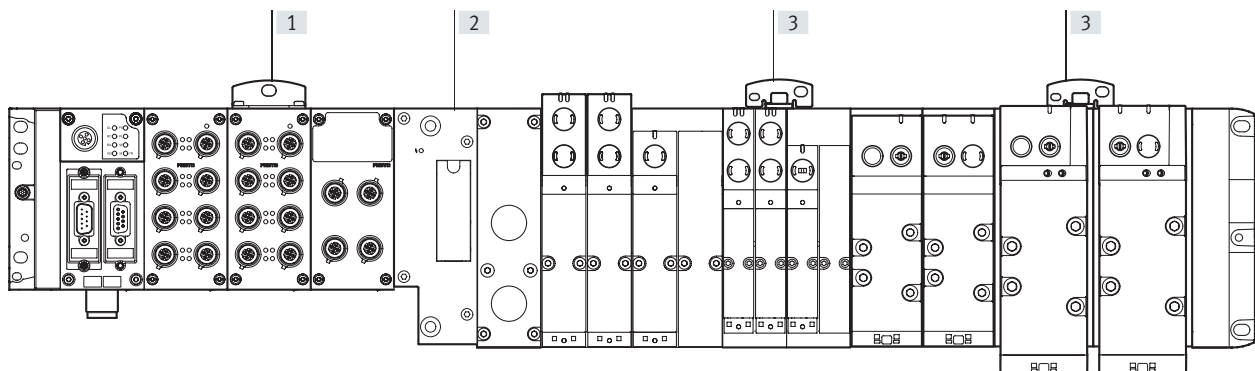

[1] Additional wall mounting for CPX metal design

[2] Pneumatic interface

[3] Additional wall mounting for VTSA/VTSA-F

(with drilled hole for M5 and M6 screw)

In the case of metal CPX terminals with 4 and more interlinking blocks, additional wall mountings of the type CPX-M-BG-RW must be used every 100 ... 150 mm. These wall mountings are screwed in at the top of the corresponding CPX module.

In the case of the VTSA/VTSA-F, mounting brackets must be mounted on the wall as instructed above.

Brackets of the type VAME-S6-W-M46 must be used as an additional wall mounting.

Mounting on support system with CPX metal design

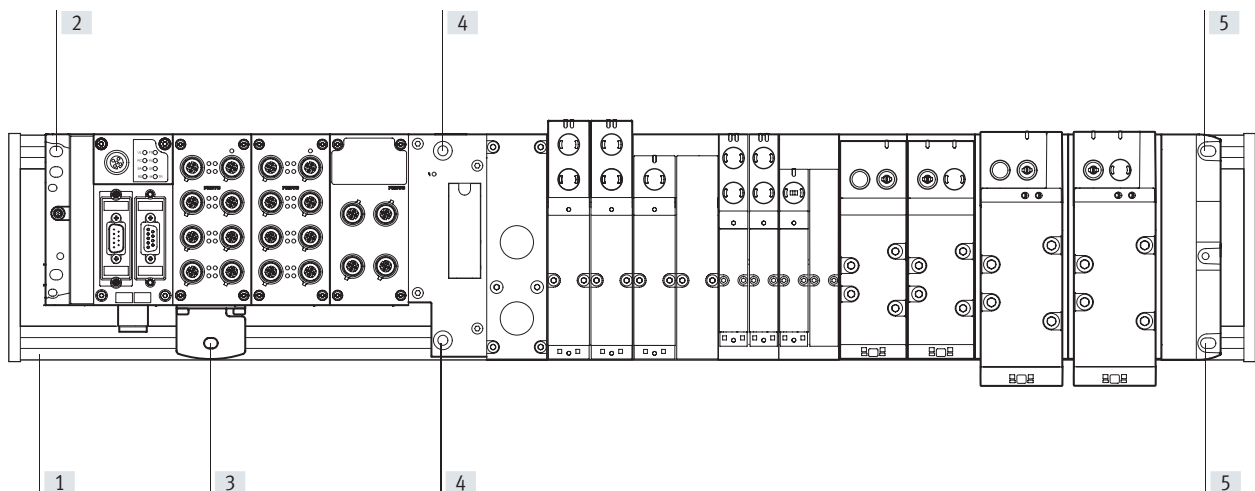

[1] Support system (DIN mounting rail)

[2] Upper mounting for metal CPX, left end plate on DIN mounting rail

[3] Lower mounting for metal CPX on DIN mounting rail with mounting bracket CPX-M-BG-VT-2X

[4] Mounting for pneumatic interface on DIN mounting rail

[5] Mounting for right end plate on DIN mounting rail

If a metal terminal CPX with VTSA pneumatic components is mounted on DIN mounting rails, it may be necessary to have one or more mounting brackets on the CPX side to compensate for the length. It is possible to compensate for the length by using special mounting brackets CPX-M-BG-VT-2X. The mounting bracket connects the metal terminal CPX to the DIN mounting rail.

Note

- Only metal CPX modules with VTSA/VTSA-F modules of width 18 ... 52 mm must be used.
- The number of mounting brackets required depends on the number of CPX modules installed and whether any system feeds are present.

Further information about mounting the valve terminal can be found in the assembly instructions in the Festo Support Portal
→ www.festo.com/sp

Key features – Mounting

DIN rail mounting

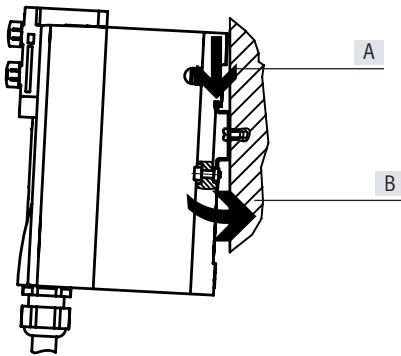

The valve terminal VTSA/VTSA-F is hooked onto the DIN rail (see arrow A). It is then swivelled onto the DIN rail and secured in place with the clamping component (see arrow B).

The following VTSA/VTSA-F mounting is required for DIN rail mounting of the valve terminal:

- CPX-CPA-BG-NRH

This enables the valve terminal to be mounted on a DIN rail to EN 60715.

Note

- Wall mounting is recommended if more than one vertical stacking element or a long valve terminal design is required.
- Vibration/shock loads are not permitted for DIN rail mounting.
- Only horizontal installation is permitted for DIN rail mounting.

Individual valve mounting

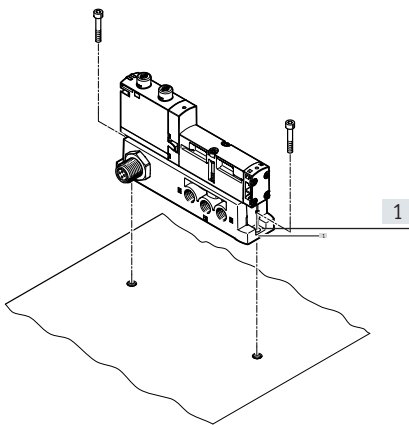

[1] Vertical mounting holes

The individual sub-base for wall mounting is designed for integration into a system or machine. It is mounted vertically.

Key features – Display and operation

Indicators and operation

Each solenoid coil is allocated an LED which indicates its switching status.

- Indicator 12 shows the signal status of the pilot control for output 2
- Indicator 14 shows the signal status of the pilot control for output 4

Manual override (MO):

The manual override enables the valve to be switched when not electrically actuated or energised.

The valve is switched by pushing the manual override. The set switching status can also be locked by turning the manual override.

Alternatives:

- The cover cap (code N) limits the function of the manual override, preventing it from being locked. The valve can then only be actuated as non-detenting.
- The cover cap (code V) can be used to secure the manual override against accidental actuation.
- The heavy-duty cover cap protects the manual override located on the valve. The valve can be actuated as non-detenting or as detenting via accessory.

Note

Special valve variants with pre-assembled cover caps for the manual override are available for valve terminal VTSA/VTSA-F.

Pneumatic connection and control elements

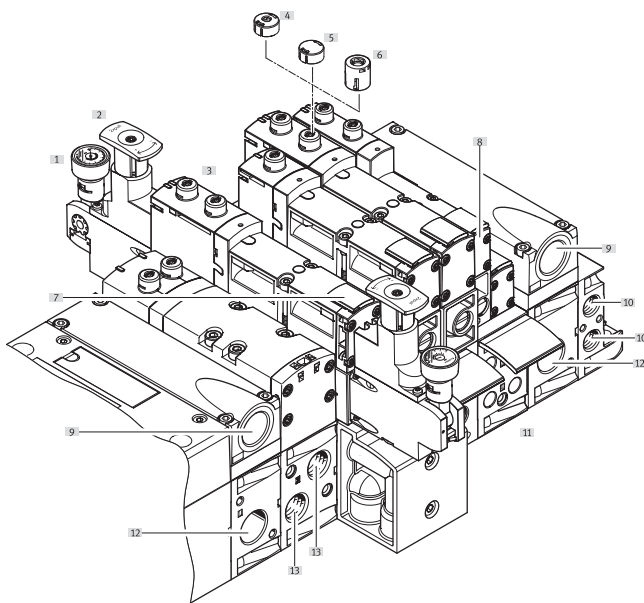

- [1] Pressure gauge (optional)
- [2] Adjusting knob for optional pressure regulator plate
- [3] Manual override (MO) (for each pilot solenoid coil, non-detenting or non-detenting/detenting)
- [4] Cover cap for MO, non-detenting
- [5] Cover cap for MO, concealed
- [6] Cover cap for MO, non-detenting, heavy-duty, detenting via accessory
- [7] Inscription label holder for valve
- [8] Adjusting screw of optional throttle plate
- [9] Exhaust ports "Valves" (3/5)
- [10] Pilot ports 12 and 14 for supplying the external pilot air
- [11] Inscription label holder for sub-base
- [12] Supply port 1 (operating pressure)
- [13] Working ports 2 and 4, per valve position

Note

A manually operated valve (manual override) cannot be reset electrically. Conversely, an electrically actuated valve cannot be reset using the mechanical manual override.

Electrical connection and indicator elements

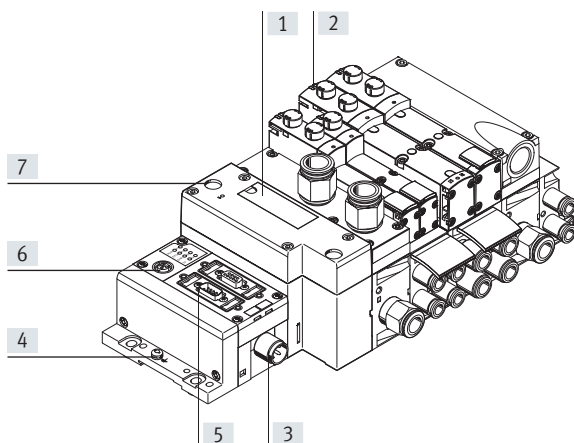

- [1] Inscription area and covering for DIN rail mounting
- [2] Yellow LEDs: signal status indication for the pilot solenoid coils
- [3] Power supply connection
- [4] Earthing connection
- [5] Fieldbus interface (bus-specific)
- [6] Service interface
- [7] Red LED: common error display for valves

Key features – Display and operation

Electrical connection and indicator elements for AP interface

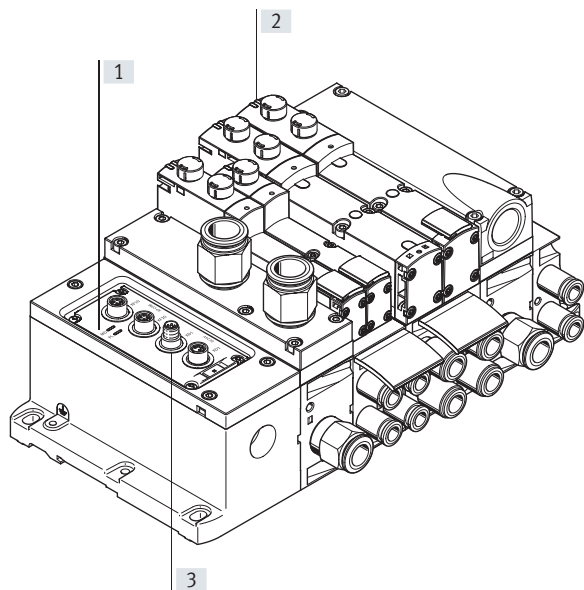

- [1] LED indicators for operating status/diagnostics of the pneumatic interface
- [2] Yellow LEDs: signal status indication for the pilot solenoid coils
- [3] AP interface with connections

Key features – Display and operation

Manual override (MO) – Function

MO with automatic return (non-detenting)

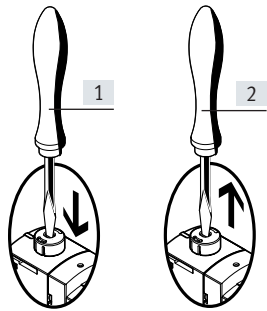

- [1] Press in the plunger of the manual override using a pointed object or screwdriver. The valve is in the switching position.
- [2] Remove the pointed object or screwdriver. The spring force pushes the plunger of the manual override back. The valve returns to its normal position (not with double solenoid valve code J or D).

MO with detent (concealed)

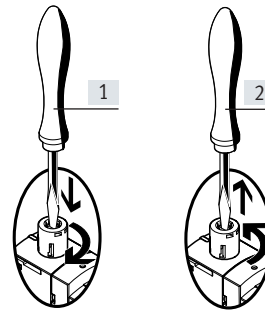

- [1] Press in the plunger of the manual override using a pointed object or screwdriver until the valve switches and then turn the plunger 90° clockwise until the stop is reached. Valve remains in the switching position.
- [2] Turn the plunger 90° anticlockwise until the stop is reached and then remove the pointed object or screwdriver. The spring force pushes the plunger of the manual override back. The valve returns to its normal position (not with double solenoid valve code J or D).

Cover caps for manual override

Cover cap for MO, heavy-duty, with automatic reset (non-detenting/detenting via accessory)

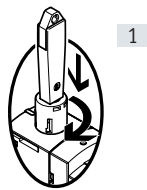

- [1] Non-detenting: Push in key for MO. The valve is in the switching position. Detenting: Turn the coded key in switching position clockwise through 90° until the stop is reached. Valve remains in the switching position. In this position the key is latched and cannot be removed.

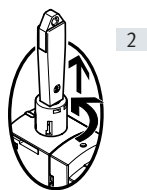

- [2] Turn the key 90° anticlockwise until the stop is reached. The key is now unlatched. The spring force of the manual override pushes the key back out. The valve returns to its normal position (not with double solenoid valve code J or D).

Cover cap for MO, with automatic return (non-detenting)

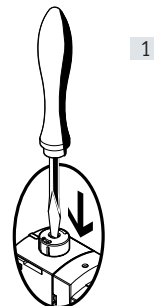

- [1] Restricted function, non-detenting: push in the plunger of the MO cap using a pointed object or screwdriver. The valve is in the switching position.

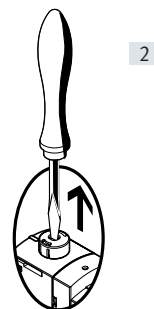

- [2] Remove the pointed object or screwdriver. The spring force pushes the plunger of the manual override back. The valve returns to its normal position (not with double solenoid valve code J or D).

Cover cap for MO, concealed

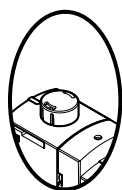





When concealed by the cover cap, the MO can be secured against accidental actuation.

Note

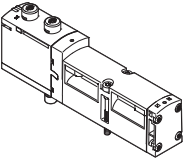
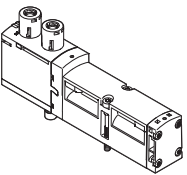
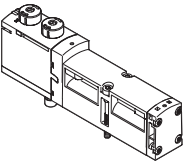
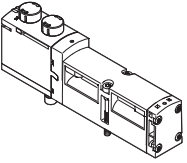
Cover caps for the manual override can be ordered separately as accessories. There are also variants of the valves VSVA with pre-assembled cover caps.

Key features – Display and operation

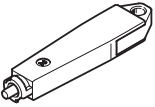
Overview of valve variants and cover caps for manual override (MO)				
Illustration	Terminal code	Description of valve terminal order code	Manual override (MO)	Valve code identification on the rating plate sticker ¹⁾
Solenoid valve VSVA without cover cap				
	R	Without cover cap on MO	Non-detenting, detenting	VSVA-B- ... -MZD- ...
Solenoid valve VSVA with ready-fitted cover cap on MO				
	B	MO non-detenting/heavy duty with cover cap, can be used as detenting via accessory (key), as valve variant	Non-detenting, detenting via accessory (key)	VSVA-B- ... -MZTR- ...
	C	MO can only be used as non-detenting with coded cover cap, as valve variant	Non-detenting	VSVA-B- ... -MZH- ...
	D	MO concealed by cover cap – operation of MO prevented, as valve variant	Concealed	VSVA-B- ... -MZ- ...
Cover caps for MO				
	N	MO can only be used as non-detenting with coded cover cap	Non-detenting	VSVA-B- ... -MZD- ...
	V	MO concealed by cover cap – operation of MO prevented	Concealed	VSVA-B- ... -MZD- ...
	A	MO non-detenting/heavy duty with cover cap, detenting via accessory (key)	Non-detenting, detenting via accessory	VSVA-B- ... -MZD- ...
Accessories for manual override, heavy duty				
	–	Coded key (accessory) for actuating the MO, non-detenting/heavy duty, for detenting position	For manual override, detenting	–

1) As an example, the part code for a 5/2-way single solenoid valve, mechanical spring return is used here (e.g. VSVA-B-M52-MZTR-A2-1T1L)

 **Note**

Cover caps for non-detenting/heavy duty manual override, detenting via accessory, are provided for one-off use only. If they are used more than once, reliable locking of the cover cap cannot be guaranteed.

Key features – Electrical components

Inscription system

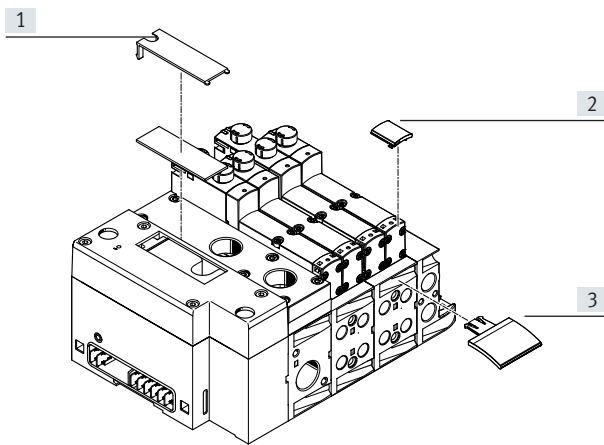

- [1] Inscription area (approx. 20 x 45 mm)
- [2] Inscription label holder for valve ASCF-T-S6 (17 x 12.5 mm), ASCF-T-S6-Z
- [3] Inscription label holder for manifold sub-base ASCF-M-S6, ASCF-M-S2-2

Inscription label holders can be applied to the valves and manifold sub-bases to identify them. They can be ordered by entering the code B or T in the order code for accessories.

Scope of delivery: inscription label holder including inscription label. The following inscription labels can be used as spares:

- Inscription label holder for valve type ASCF-T-S6: part no. 540888
- Inscription label holder with additional fields for marking valve type ASCF-T-S6-Z: part no. 8106532

- Inscription label holder for manifold sub-base type ASCF-M-S6: part no. 540889
 - Inscription label holder for manifold sub-base (for valve width 52 mm) type ASCF-M-S2-2: part no. 562577
- Large inscription labels can be attached to the pneumatic interface as an alternative or in addition to the smaller labels.

Protective circuit

Each solenoid coil VSVA is provided with a spark arresting protective circuit and protected against polarity reversal.

The 24 V DC version of width 52 mm additionally features integrated holding current reduction.

24 V DC version (width 18 to 42 mm)

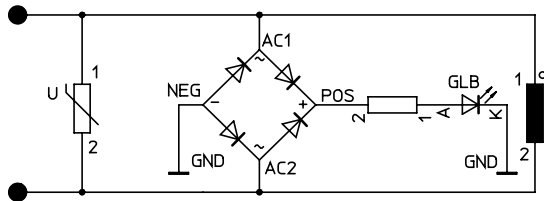

24 V DC version (width 52 mm)

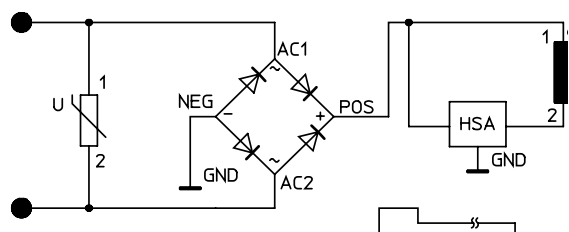

Note

All control signals of the solenoid coils of a valve terminal share a common load (independent of whether multi-pin, AS-i or CPX).

Key features – Electrical components

Individual valve

Valves on individual sub-bases can be used for actuators that are further away from the valve terminal.

- Electrical connection M12, 4-pin 24 V DC
- 4-pin clamped terminal connection for configuration by the user 24 V DC
- Cable (open end) for configuration by the user 24 V DC

Individual electrical connection

A maximum of 20 solenoid coils can be actuated. 2 solenoid coils per valve can be addressed.

Individual electrical connection:

- M12
- 6-way or 10-way
- 5-pin
- 24 V DC

Electrical multi-pin plug connection

The following multi-pin plug connection variants are offered for the valve terminal VTSA/VTSA-F:

- Sub-D multi-pin plug connection (37-pin for 24 V DC): This valve terminal can be equipped with 1 ... 16 valve positions (with double solenoid valves), or with 1 ... 32 valve positions (with single solenoid valves). A maximum of 32 solenoid coils can be actuated.
- Terminal box (terminal strip for 24 V DC): This valve terminal can be equipped with 1 ... 16 valve positions (with double solenoid valves), or with 1 ... 32 valve positions (with single solenoid valves).

A maximum of 32 solenoid coils can be actuated.

- Multi-pin node (round plug): electrical multi-pin plug connection with round plug connector, 19-pin to CNOMO E03.62.530.N, connecting thread M23 for 24 V DC. The valve terminal can be fitted with max. 16 solenoid coils.

The valves are switched by positive or negative logic (PNP or NPN). Mixed operation is not permissible because all control signals of the solenoid coils of a valve terminal share a common load.

Each pin on the multi-pin plug (Sub-D) or terminal box (terminal strip) can actuate exactly one solenoid coil. If the maximum configurable number of valve positions is 32, this means that 32 valves can be addressed, each with a single solenoid coil.

With 16 or fewer valve positions, 2 solenoid coils per valve can be addressed.



Note

Use the following 37-pin connecting cables from Festo to connect the valve terminal VTSA/VTSA-F with Sub-D multi-pin plug connection:

- NEBV-...-LE10 for max. 8 solenoid coils
- NEBV-...-LE26 for max. 22 solenoid coils
- NEBV-...-LE27 for max. 23 solenoid coils
- NEBV-...-LE37 for max. 32 solenoid coils
- NECV-S1W37 pre-assembled plug connector

AS-Interface connection

Valve terminals VTSA/VTSA-F with AS-Interface connection can be expanded with up to 8 valves with max. 8 solenoid coils.

The valve terminal with AS-Interface connection is based on the same electrical links as the valve terminal with multi-pin plug connection.

This means a valve terminal with multi-pin plug connection can be converted using an AS-Interface module.

The technical specifications of the AS-Interface system must be observed in this case.



Note

AS-Interface module VAEM-S6-S-FAS-4-4E

Always operate the AS-Interface module with additional power supply if 4 solenoid coils (width 52 mm) are supplied with current simultaneously.

More information can be found at:
→ Internet: as-interface

Fieldbus interface/control block

All functions and features of the electrical peripherals CPX are permitted in connection with the CPX interface. This means that:

- The valves and electrical outputs are supplied via the operating voltage connection CPX
- The valves are supplied and switched off independently via a separate connection on the CPX



Note

More information can be found at:
→ Internet: cpx

Key features – Electrical components

I-Port/IO-Link®

Valve terminals VTSA/VTSA-F with I-Port/IO-Link® connection can be expanded with up to 16 valves with max. 32 solenoid coils.

The valve terminal with I-Port/IO-Link® connection is based on the same electrical links as the valve terminal with multi-pin plug connection.

This means a valve terminal with multi-pin plug connection can be converted using an I-Port/IO-Link® module. The technical specifications of the I-Port/IO-Link® system must be observed in this case.



Note

AS-i module VAEM-S6-S-FAS-4-4E. Always operate the AS-i module with additional power supply if max. 4 solenoid coils (width 52 mm) are simultaneously supplied with current.

More information can be found at:
→ Internet: i-port, io-link

AP interface

VTSA/VTSA-F valve terminals with AP interface can be expanded with up to 12 valves with a maximum of 24 solenoid coils.

The valve terminal with AP interface is based on the same electrical links as the valve terminal with multi-pin plug connection.

This means a valve terminal with multi-pin plug connection can be converted using an AP interface. The technical specifications of the AP interface must be observed in this case.



Note

AS-i module VAEM-S6-S-FAS-4-4E. Always operate the AS-i module with additional power supply if max. 4 solenoid coils (width 52 mm) are simultaneously supplied with current.

More information can be found at:
→ Internet: ap

Key features – Electrical components

Rules for addressing

Address allocation

Address allocation doesn't depend on whether single or double solenoid valves are fitted.

Addresses are assigned in ascending order without gaps, from left to right.

Single solenoid valve

A valve position for actuating one solenoid coil (VABV...T1) occupies one address.

Double solenoid valve

A valve position for actuating two solenoid coils (VABV...T2) occupies two addresses. The following allocation applies in this case:



- Coil 14: lower-value address
- Coil 12: higher-value address

Connecting cable

The wire colours refer to the following pre-assembled connecting cables from Festo:

- NEBV-...-LE10 for valve terminal with max. 8 solenoid coils
- NEBV-...-LE26 for valve terminal with max. 22 solenoid coils
- NEBV-...-LE27 for valve terminal with max. 23 solenoid coils
- NEBV-...-LE37 for valve terminal with max. 32 solenoid coils

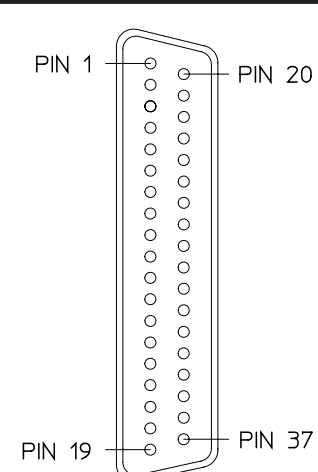
Pin allocation – Multi-pin plug, Sub-D socket, 24 V DC, electrical control code MP1

	Pin ²⁾	Address/coil	Wire colour ¹⁾		Pin ²⁾	Address/coil	Wire colour ¹⁾
	1	0	WH		17	16	WH PK
	2	1	BN		18	17	PK BN
	3	2	GN		19	18	WH BU
	4	3	YE		20	19	BN BU
	5	4	GY		21	20	WH RD
	6	5	PK		22	21	BN RD
	7	6	BU		23	22	GY GN
	8	7	RD		24	23	YE GY
	9	8	GY PK		25	24	PK GN
	10	9	RD BU		26	25	YE PK
	11	10	WH GN		27	26	GN BU
	12	11	BN GN		28	27	YE BU
	13	12	WH YE		29	28	GN RD
	14	13	YE BN		30	29	YE RD
	15	14	WH GY		31	30	GN BK
	16	15	GY BN		32	31	GY BU
 Note The drawing shows a plan view of the Sub-D plug socket at the connecting cable NEBV-...	Conductor						
	33	0 V ³⁾	YE BK		35	0 V ³⁾	BN BK
	34	0 V ³⁾	WH BK		36	0 V ³⁾	BK
Earthing							
37	FE	VT		–	–	–	

1) To IEC 757

2) Pin 9 ... 35: not allocated in the case of connecting cable NEBV-...-LE10

Pin 23 ... 33: not allocated in the case of connecting cable NEBV-...-LE26

Pin 24 ... 33: not allocated in the case of connecting cable NEBV-...-LE27

3) Connect 0 V for positive-switching control signals, 24 V for negative-switching control signals. Mixed operation is not permissible because all control signals of the solenoid coils of a valve terminal share a common load!

Key features – Electrical components

Dimensions

Download CAD data → www.festo.com

Connecting cable NEBV...

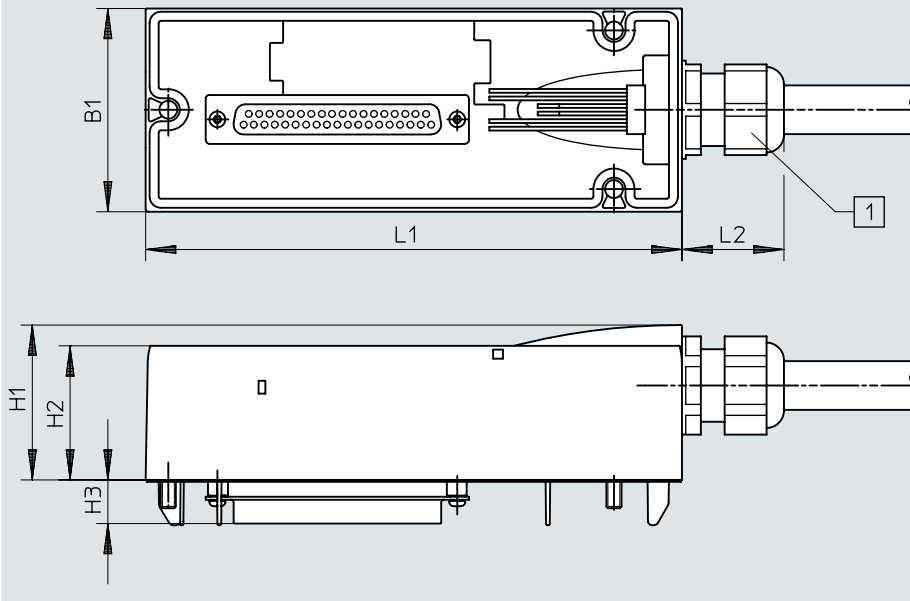

[1] Cable connector M20x1.5

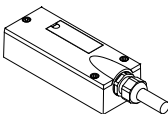

Type	B1	H1	H2	H3	L1	L2
NEBV...	54	41	36	11.6	142	27

Ordering data – Connecting cable, Sub-D, 24 V DC, electrical control code MP1

	Cable sheath	Connecting cable	Length [m]	Part no.	Type
	TPE-U(PUR)	For max. 8 solenoid coils, 10-core	2.5	539240	NEBV-S1W37-E-2.5-LE10
			5	539241	NEBV-S1W37-E-5-LE10
			10	539242	NEBV-S1W37-E-10-LE10
		For max. 22 solenoid coils, 26-core	2.5	539243	NEBV-S1W37-E-2.5-LE26
			5	539244	NEBV-S1W37-E-5-LE26
			10	539245	NEBV-S1W37-E-10-LE26
		For max. 32 solenoid coils, 37-core	2.5	539246	NEBV-S1W37-K-2.5-LE37
			5	539247	NEBV-S1W37-K-5-LE37
			10	539248	NEBV-S1W37-K-10-LE37
	PVC	For max. 8 solenoid coils, 10-core	2.5	543271	NEBV-S1W37-KM-2.5-LE10
			5	543272	NEBV-S1W37-KM-5-LE10
			10	543273	NEBV-S1W37-KM-10-LE10
		For max. 23 solenoid coils, 27-core	2.5	543274	NEBV-S1W37-KM-2.5-LE27
			5	543275	NEBV-S1W37-KM-5-LE27
			10	543276	NEBV-S1W37-KM-10-LE27
For max. 32 solenoid coils, 37-core		2.5	543277	NEBV-S1W37-KM-2.5-LE37	
		5	543278	NEBV-S1W37-KM-5-LE37	
		10	543279	NEBV-S1W37-KM-10-LE37	

Key features – Electrical components

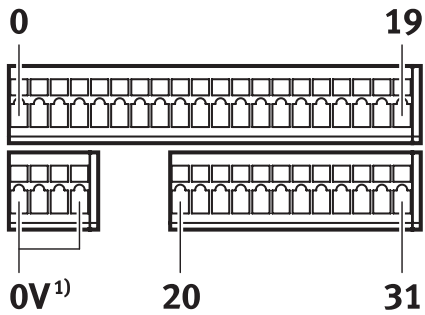
Pin allocation – Multi-pin, terminal strip (Cage Clamp), 24 V DC; electrical control code T (based on standard: EN 61984)

	Terminal	Coil/address		Terminal	Coil/address
Each solenoid coil is assigned to a specific terminal on the terminal strip in order for the valves to be actuated.					
	1	0		17	16
	2	1		18	17
	3	2		19	18
	4	3		20	19
	5	4		21	20
	6	5		22	21
	7	6		23	22
	8	7		24	23
	9	8		25	24
	10	9		26	25
	11	10		27	26
	12	11		28	27
	13	12		29	28
	14	13		30	29
	15	14		31	30
	16	15		32	31
	 Note The drawing shows a plan view of the multi-pin terminal strip (Cage Clamp).	Conductor			
33		0 V		35	0 V
34		0 V		36	0 V

Pin allocation – Multi-pin, round plug connector, 24 V DC; electrical control code MP4

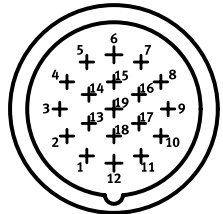
	Address	Pin ¹⁾		Address	Pin ¹⁾
	0	15		8	17
	1	7		9	9
	2	5		10	2
	3	4		11	13
	4	16		12	11
	5	8		13	10
	6	3		14	1
	7	14		15	18

Pin allocation – Multi-pin plug, round plug connector, 24 V DC; electrical actuation – CNOMO allocation

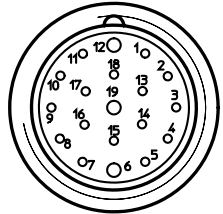
	Pin	Valve position/solenoid coil		Pin	Valve position/solenoid coil
	1	8/14		11	7/14
	2	6/14		12	FE
	3	4/14		13	6/12
	4	2/12		14	4/12
	5	2/14		15	1/14
	6	0 V ¹⁾		16	3/14
	7	1/12		17	5/14
	8	3/12		18	8/12
	9	5/12		19	Not assigned
	10	7/12			

1) Pin 6: 0 V for positive-switching control signals; connect 24 V for negative-switching control signals; mixed operation is not permitted!
Pin 12: earth
Pin 19: not allocated

Key features – Electrical components

Electrical connection, individual valve 24 V DC up to width 52 mm

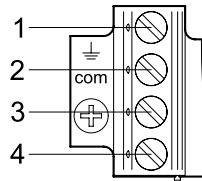
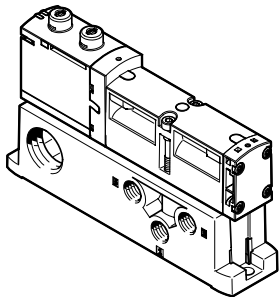

Pin assignment for assembly by the user

With positive control signal:

- Pin1 – Not allocated
- Pin2 – U_B for coil 12
- Pin3 – 0 V for coil 12 and 14
- Pin4 – U_B for coil 14

With negative control signal:

- Pin1 – Not allocated
- Pin2 – 0 V for coil 12
- Pin3 – U_B for coil 12 and 14
- Pin4 – 0 V for coil 14

Individual electrical connection, 6-way or 10-way, 24 V DC, code MP2/MP3 for valve terminal up to width 52 mm

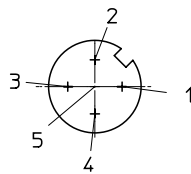
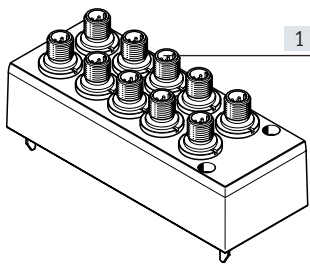

[1] Connection plug M12x1, 5-pin

Pin assignment M12

With positive control signal:

- Pin1 – Not allocated
- Pin2 – U_B for coil 12
- Pin3 – 0 V for coil 12 and 14
- Pin4 – U_B for coil 14
- Pin5 – Functional earth

Pin assignment M12

With negative control signal:

- Pin1 – Not allocated
- Pin2 – 0 V for coil 12
- Pin3 – U_B for coil 12 and 14
- Pin4 – 0 V for coil 14
- Pin5 – Functional earth

 Note

- Mixed operation of positive-switching (PNP) and negative-switching (NPN) control signals is not permissible because all control signals of the solenoid coils of a valve terminal share a common load.
- All M12 connections (MP2/MP3) within a valve terminal share a common load.

Instructions for use

Operating materials

Operate your system with unlubricated compressed air, if possible. Festo valves and cylinders are designed so that, if used as intended, they will not require additional lubrication and will still achieve a long service life.

The quality of compressed air downstream of the compressor must correspond to that of unlubricated compressed air. If possible, do not operate the entire system with lubricated compressed air. The lubricators should, where possible, always be installed directly upstream of the actuator requiring them.

Incorrect additional oil and too high an oil content in the compressed air reduce the service life of the valve terminal.

Use Festo special oil OFSW-32 or the alternatives listed in the Festo catalogue (as specified in DIN 51524 HLP32; basic oil viscosity 32 CST at 40 °C).

Bio-oils

When using bio-oils (oils which are based on synthetic or native esters, e.g. rapeseed oil methyl ester), the maximum residual oil content of 0.1 mg/m³ must not be exceeded (see ISO 8573-1:2010 Class 2).

Mineral oils

When using mineral oils (e.g. HLP oils to DIN 51524, parts 1 to 3) or similar oils based on poly-alpha-olefins (PAO), the maximum residual oil content of 5 mg/m³ must not be exceeded (see ISO 8573-1:2010 Class 4).

A higher residual oil content is not permitted, regardless of the compressor oil, because the permanent lubrication would otherwise be flushed out over a period of time.

Datasheet – AP interface

Control signals from the controller to the valve terminal are transmitted via the AP bus protocol from Festo.

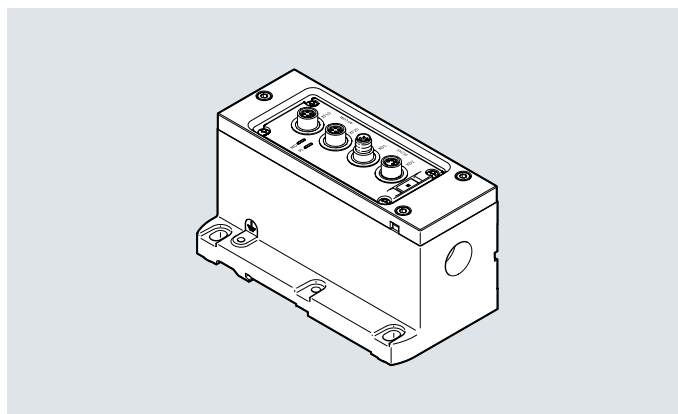

Application

The AP interface connects the VTSA valve terminal with up to 12 valves (24 valve coils) to a CPX-AP system.

Implementation

The AP interface is used for direct integration of the VTSA valve terminal into the decentralised IO system.

General technical data

AP interface

Connection position	On top
Reverse polarity protection	Yes
Number of pins/cores	4
Maximum number of valve positions	12
Maximum number of solenoid coils	24

Datasheet – AP interface

General data		
Diagnosics via LED		Diagnosics per module
		Power supply load
Diagnosics via internal communication		Load switch-off
		Electronics/sensors overvoltage
		Undervoltage load
Module parameters		Configuration of voltage monitoring load supply PL
		Response in error state
Technical data – Electrics		
Nominal operating voltage	[V AC]	110
	[V DC]	24
Nominal operating voltage for electrics/sensors	[V DC]	24
Nominal operating voltage, load	[V DC]	24
Permissible voltage fluctuations, electrics/sensors	[%]	± 25
Permissible voltage fluctuations, load	[%]	± 10
Intrinsic current consumption of electrics/sensors	[mA]	Typ. 34 mA
Intrinsic current consumption of load	[mA]	Typ. 16 mA
Max. power supply	[A]	4 ... 16
Power failure buffering	[ms]	10
Power failure buffering of load	[ms]	3
Fuse protection (short circuit)		Internal electronic fuse per channel
Power supply		
Function		Incoming electronics/sensors and load
Connection type		Plug
Connection technology		M8x1, A-coded to EN 61076-2-104
		M12x1, D-coded to EN 61076-2-101
		RJ45 to IEC 61076-3-117 (V14)
		SCRJ to IEC 61754-24-21
Number of pins/cores		4
Voltage transmission		
Function		Outgoing electronics/sensors and load
Connection type		Socket
Connection technology		M8x1, A-coded to EN 61076-2-104
		M12x1, D-coded to EN 61076-2-101
		RJ45 to IEC 61076-3-117 (V14)
		SCRJ to IEC 61754-24-21
Number of pins/cores		4
Technical data – Mechanical components		
Product weight	[g]	712
Dimensions W x L x H	[mm]	71 x 142 x 84
Materials		
Cover		Die-cast aluminium
Threaded sleeve		Nickel-plated brass
Note on materials		RoHS-compliant
LABS (PWIS) conformity		VDMA24364-B2-L

Datasheet – AP interface

Operating and environmental conditions		
Ambient temperature	[°C]	+5 ... +50
Note on ambient temperature		Note ambient temperature derating to IEC 61131-2:2017
Storage temperature	[°C]	-20 ... +60
Relative humidity	[%]	5 ... 95
		Non-condensing
Corrosion resistance class CRC ¹⁾		2
CE marking (see declaration of conformity) ²⁾		To EU EMC Directive
		To EU RoHS Directive
Certification		RCM
Degree of protection		IP65
Note on degree of protection		In mounted state
		Seal unused connections
Nominal operating altitude	[m]	≤ 2000 NHN
Maximum cable length	[m]	50, system communication
Maximum setup altitude	[m]	3500
Note on the maximum setup altitude		> 2000 m ASL (< 79.5 kPa)
		Note ambient temperature derating to IEC 61131-2:2017

1) More information www.festo.com/x/topic/crc2) More information www.festo.com/catalogue/... → Support/Downloads.

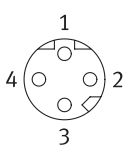
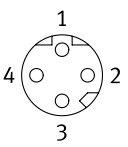
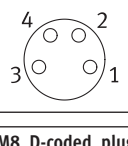
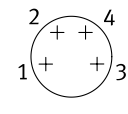
Pin assignment			
	Pin	Assignment	Description
M8, D-coded, socket			
AP in (AP-COM) 	1	TX-	AP bus, transmission signal positive
	2	RX+	AP bus, receive signal positive
	3	TX+	AP bus, receive signal negative
	4	RX-	AP bus, transmission signal negative
AP out (AP-COM) 	1	RX-	AP bus, transmission signal positive
	2	TX+	AP bus, receive signal positive
	3	RX+	AP bus, receive signal negative
	4	TX-	AP bus, transmission signal negative
Power out (voltage transmission) 	1	24 V PS	Supply voltage for electronics and sensors
	2	0 V PL	Supply voltage for valves and outputs
	3	0 V PS	Supply voltage for electronics and sensors
	4	24 V PL	Supply voltage for valves and outputs
M8, D-coded, plug			
Power In (power supply) 	1	24 V PS	Supply voltage for electronics and sensors
	2	0 V PL	Supply voltage for valves and outputs
	3	0 V PS	Supply voltage for electronics and sensors
	4	24 V PL	Supply voltage for valves and outputs

Datasheet – AP interface

Connection and indicator components

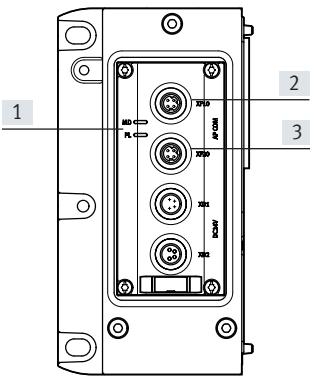

[1] LED displays for module diagnostics (MD) and power load (PL)
 [2] AP in (AP-COM)
 [3] AP out (AP-COM)
 [4] Power in (power supply)
 [5] Power out (voltage transmission)

Dimensions

Download CAD data → www.festo.com

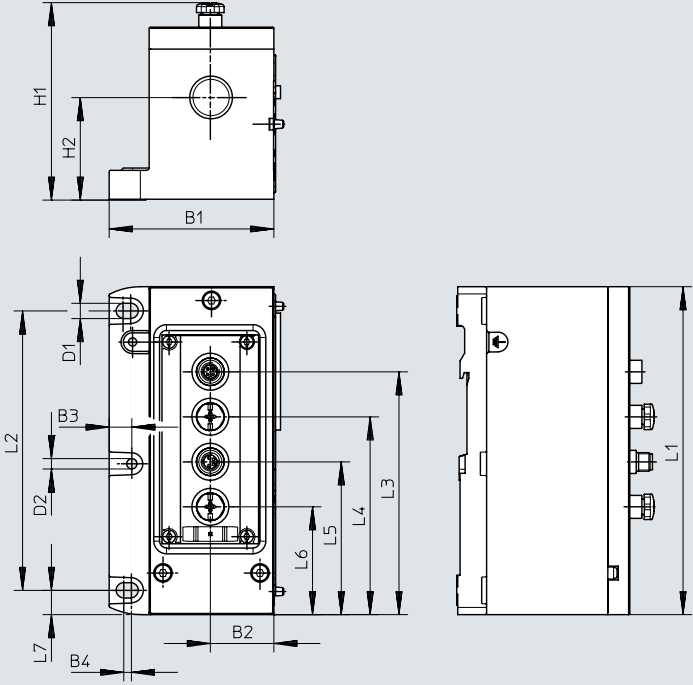

Type	B1	B2	B3	B4	D1	D2	H1	H2
VABA-S6-1-AP	71.3	27.5	9.8	3	6.6	4.5	85.5	44.4

Type	L1	L2	L3	L4	L5	L6	L7
VABA-S6-1-AP	142	121	105.2	85.7	66.2	46.7	10.5

Ordering data – AP interface

	Description	Part no.	Type
	AP interface for operation in an AP system	8152356	VABA-S6-1-AP

Datasheet – Valve terminal

-  - Valve width
to ISO 15407-2
- 18 mm
 - 26 mm
- to ISO 5599-2
- 42 mm (ISO 1)
 - 52 mm (ISO 2)

-  - Voltage
24 V DC

-  - Flow rate¹⁾
- Width 18 mm: up to
550 (700) l/min
- Width 26 mm: up to
1100 (1350) l/min
- Width 42 mm: up to
1300 (1860) l/min
- Width 52 mm
up to 2900 l/min

-  - Repair service

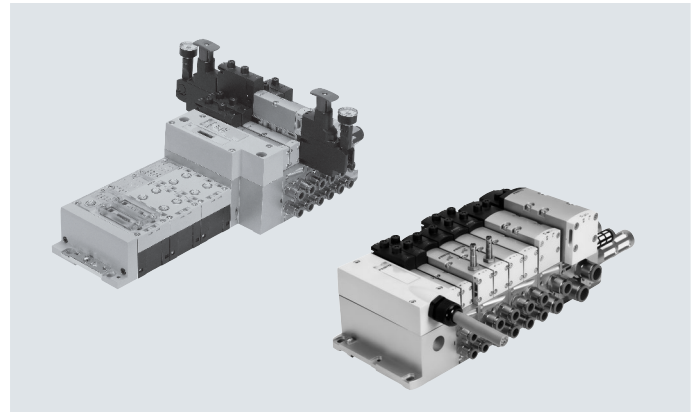

1) Flow rates in brackets apply to VTSA-F

General technical data	
Terminal type VTSA/VTSA-F	VTSA is the standard version, VTSA-F is the version with optimised flow rate
Valve sizes	Width 18 mm, 26 mm, 42 mm, 52 mm
Actuation type	Electrical
Electrical control	With multi-pin plug: multi-pin
	With fieldbus: integrated controller, fieldbus, Industrial Ethernet
Type of control	Piloted
Exhaust function, can be throttled	Via throttle plate
Type of mounting	Wall mounting
	On DIN rail to EN 60715
Mounting position	Any
Manual override	Detenting, non-detenting, concealed
Suitable for vacuum	Yes
Valve terminal design	Modular, valve sizes can be mixed
Max. number of valve positions	32 ¹⁾
Pneumatic connections – NPT thread	
Pneumatic connection	Via manifold sub-base
Supply port	1
Exhaust port	3/5
Working ports	2/4
External pilot air supply port	14
Pilot exhaust air port	12

1) Dependent on the electrical interface and the manifold sub-bases used

† Note: This product conforms to ISO 1179-1 and ISO 228-1.

Datasheet – Valve terminal

Standard nominal flow rate of valve/valve terminal [l/min]							
Valve function (with valve code)	Terminal code	Width 18 mm			Width 26 mm		
		Valve	Valve on valve terminal VTSA	Valve on valve terminal VTSA-F	Valve	Valve on valve terminal VTSA	Valve on valve terminal VTSA-F
5/2-way double solenoid (B52)	J	750	550	700	1400	1100	1350
5/2-way double solenoid with dominant signal (D52)	D	750	550	700	1400	1100	1350
5/2-way single solenoid, pneumatic spring (M52A)	M	750	550	700	1400	1100	1350
5/2-way single solenoid, mechanical spring (M52M)	O	750	550	700	1400	1100	1350
5/3-way closed (P53C)	G	700	450	650	1400 ¹⁾ 700 ²⁾	1000 ¹⁾ 700 ²⁾	1350 ¹⁾ 700 ²⁾
5/3-way exhausted (P53E)	E	700 ¹⁾ 330 ²⁾	450 ¹⁾ 330 ²⁾	480 ¹⁾ 330 ²⁾	1400 ¹⁾ 700 ²⁾	1000 ¹⁾ 700 ²⁾	1350 ¹⁾ 700 ²⁾
5/3-way pressurised (P53U)	B	700 ¹⁾ 330 ²⁾	450 ¹⁾ 330 ²⁾	480 ¹⁾ 330 ²⁾	1400 ¹⁾ 700 ²⁾	1000 ¹⁾ 700 ²⁾	1350 ¹⁾ 700 ²⁾
5/3-way exhausted, switching position 14 detenting (P53ED)	SA	–	380 ¹⁾ 310 ²⁾	430 ¹⁾ 360 ²⁾	1400 ¹⁾ 700 ²⁾	1000 ¹⁾ 700 ²⁾	1350 ¹⁾ 700 ²⁾
5/3-way exhausted, switching position 12 detenting (P53EP)	SE	–	380 ¹⁾ 300 ²⁾	460 ¹⁾ 350 ²⁾	1400 ¹⁾ 700 ²⁾	1000 ¹⁾ 700 ²⁾	1350 ¹⁾ 700 ²⁾
5/3-way, port 2 pressurised, 4 exhausted, switching position 14 detenting (P53AD)	SB	–	380 ¹⁾ 350 ²⁾	440 ¹⁾ 400 ²⁾	700 ¹⁾ 700 ²⁾	700 ¹⁾ 700 ²⁾	700 ¹⁾ 700 ²⁾
5/3-way, port 4 pressurised, 2 exhausted, switching position 14 detenting (P53BD)	SD	–	370 ¹⁾ 340 ²⁾	430 ¹⁾ 360 ²⁾	–	850 ¹⁾ 820 ²⁾	950 ¹⁾ 860 ²⁾
2x3/2-way single solenoid, closed (T32C)	K	600	400	550	1250	900	1150
2x3/2-way single solenoid, open (T32U)	N	600	400	550	1250	900	1150
2x3/2-way single solenoid, open/closed (T32H)	H	600	400	550	1250	900	1150
2x3/2-way single solenoid, closed (T32N)	Q	600	400	550	1250	900	1150
2x3/2-way single solenoid, open (T32F)	P	600	400	550	1250	900	1150
2x3/2-way single solenoid, open/closed (T32W)	R	600	400	550	1250	900	1150
2x2/2-way single solenoid, closed (T22C)	VC	700	500	650	1350	1000	1300
2x2/2-way single solenoid, closed (T22CV)	VV	700	500	650	1350	1000	1300

1) Switching position
2) Mid-position

Datasheet – Valve terminal

Standard nominal flow rate of valve/valve terminal [l/min]							
Valve function (with valve code)	Termin- al code	Width 42 mm			Width 52 mm		
		Valve	Valve on valve terminal VTSA	Valve on valve terminal VTSA-F	Valve	Valve on valve terminal VTSA	Valve on valve terminal VTSA-F
5/2-way double solenoid (B52)	J	2000	1300	1860	4000	2900	2900
5/2-way double solenoid with dominant signal (D52)	D	2000	1300	1860	4000	2900	2900
5/2-way single solenoid, pneumatic spring (M52A)	M	2000	1300	1860	4000	2900	2900
5/2-way single solenoid, mechanical spring (M52M)	O	2000	1300	1860	4000	2900	2900
5/3-way closed (P53C)	G	1900 ¹⁾ 950 ²⁾	1200 ¹⁾ 800 ²⁾	1690 ¹⁾ 830 ²⁾	3600 ¹⁾ 1700 ²⁾	2800 ¹⁾ 1700 ²⁾	2800 ¹⁾ 1700 ²⁾
5/3-way exhausted (P53E)	E	1900 ¹⁾ 950 ²⁾	1200 ¹⁾ 800 ²⁾	1690 ¹⁾ 830 ²⁾	3600 ¹⁾ 1700 ²⁾	2800 ¹⁾ 1700 ²⁾	2800 ¹⁾ 1700 ²⁾
5/3-way pressurised (P53U)	B	1900 ¹⁾ 950 ²⁾	1200 ¹⁾ 800 ²⁾	1690 ¹⁾ 830 ²⁾	3600 ¹⁾ 1700 ²⁾	2800 ¹⁾ 1700 ²⁾	2800 ¹⁾ 1700 ²⁾
5/3-way, 1 to 2 pressurised, 4 to 5 closed (P53F)	VG	1700 ¹⁾ 700 ²⁾	1400 ¹⁾ 800 ²⁾	1700 ¹⁾ 700 ²⁾	3000 ¹⁾ 900 ²⁾	2300 ¹⁾ 900 ²⁾	2300 ¹⁾ 900 ²⁾
2x3/2-way single solenoid, closed (T32C)	K	1600	1200	1300	3000	2400	2400
2x3/2-way single solenoid, open (T32U)	N	1600	1200	1300	3000	2400	2400
2x3/2-way single solenoid, open/closed (T32H)	H	1600	1200	1300	3000	2400	2400
2x3/2-way single solenoid, closed (T32N)	Q	1600	1200	1300	3000	2400	2400
2x3/2-way single solenoid, open (T32F)	P	1600	1200	1300	3000	2400	2400
2x3/2-way single solenoid, open/closed (T32W)	R	1600	1200	1300	3000	2400	2400
2x2/2-way single solenoid, closed (T22C)	VC	1600	1400	1500	4000	2800	2800
2x2/2-way single solenoid, closed (T22CV)	VV	1600	1400	1500	–	–	–

1) Switching position

2) Mid-position

Datasheet – Valve terminal

Flow rate q_n as a function of output pressure p_2 with pressure regulator plates (P regulator plate) for port 1

6 bar

10 bar

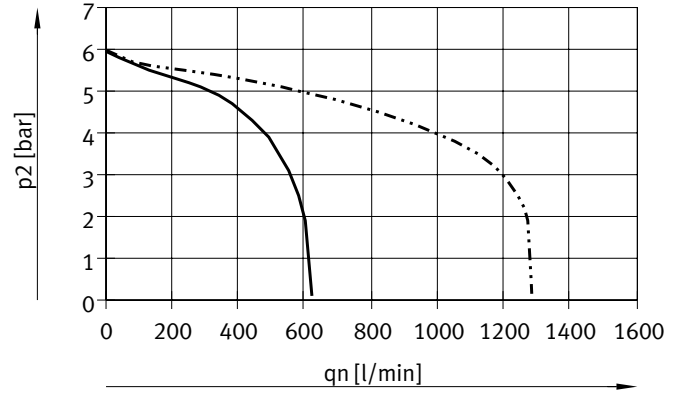
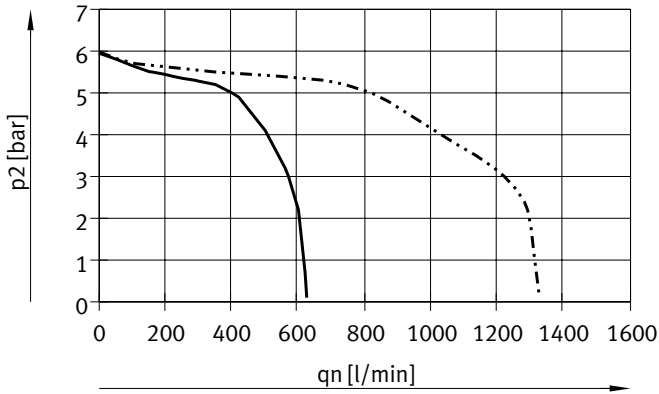

— Width 18 mm
- · - · - Width 26 mm

— Width 18 mm
- · - · - Width 26 mm

Input pressure 10 bar, regulated pressure set to 6 bar

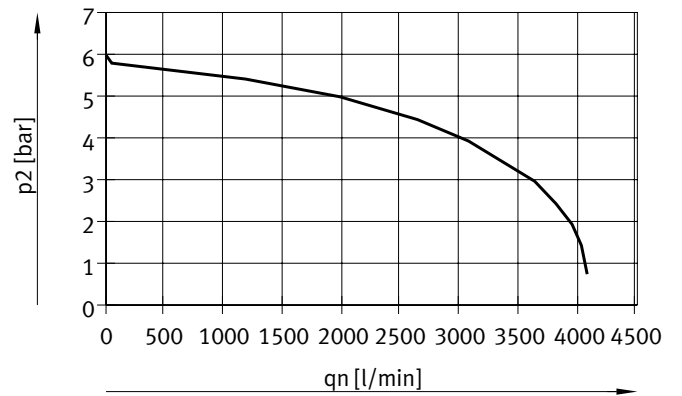
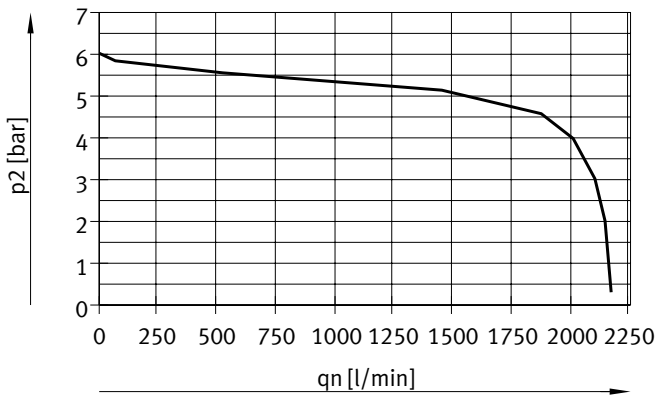

Width 42 mm (ISO 1)

Width 52 mm (ISO 2)

Datasheet – Valve terminal

Flow rate q_n as a function of output pressure p_2 with pressure regulator plates (AB regulator plates) for port 2, 4 or ports 4/2

6 bar

10 bar

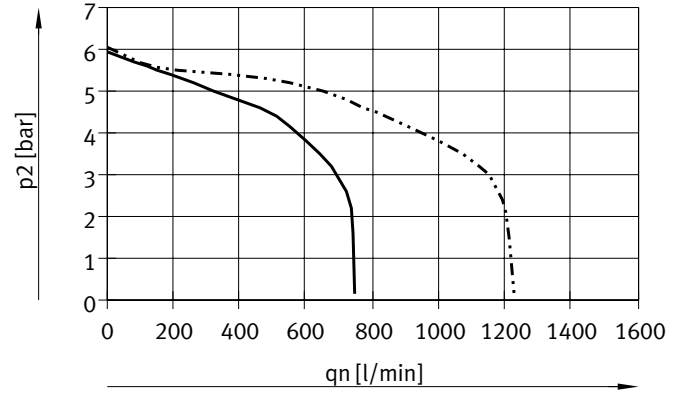
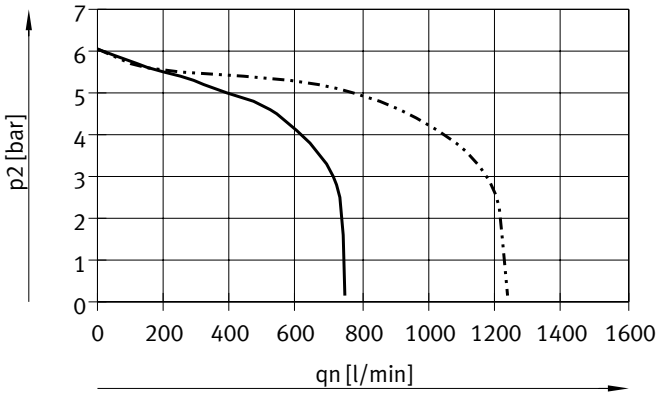

— Width 18 mm
- - - - - Width 26 mm

— Width 18 mm
- - - - - Width 26 mm

Input pressure 10 bar, regulated pressure set to 6 bar

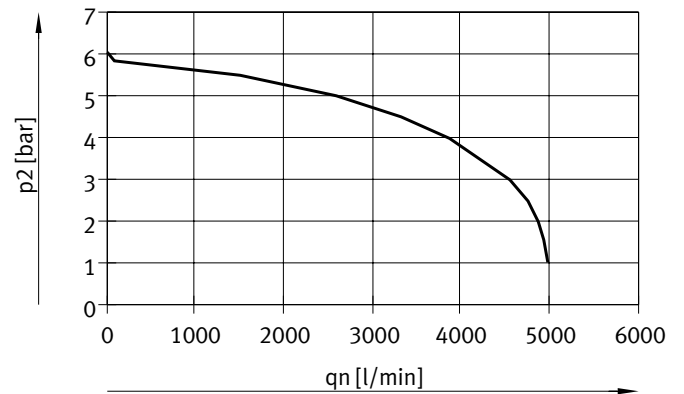
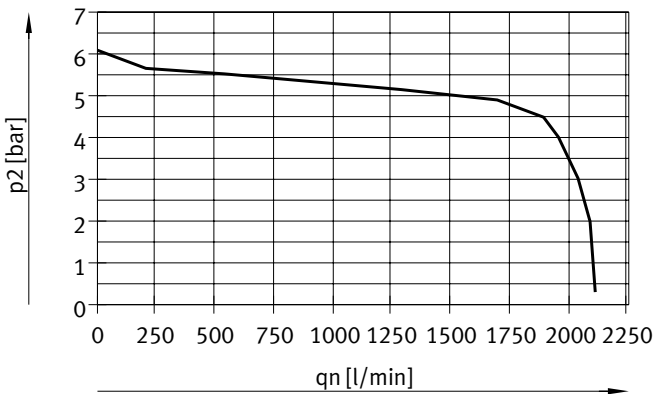

Width 42 mm (ISO 1)

Width 52 mm (ISO 2)

Datasheet – Valve terminal

Flow rate q_n as a function of output pressure p_2 with pressure regulator plates (AB regulator plates, rev.) for ports 4/2, reversible

6 bar

10 bar

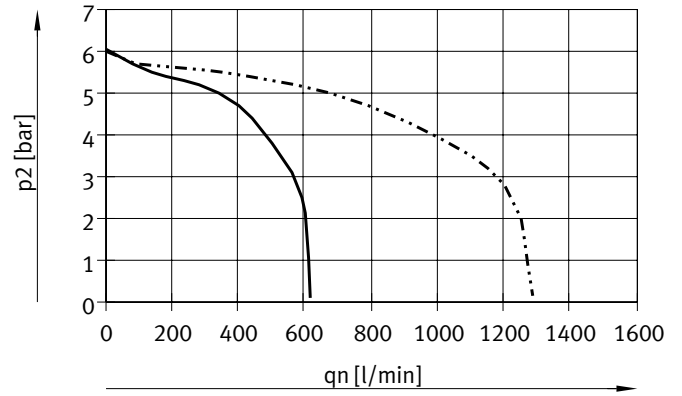
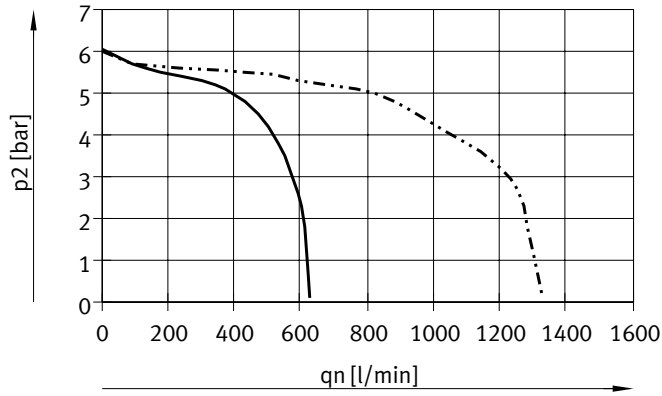

— Width 18 mm
- - - Width 26 mm

— Width 18 mm
- - - Width 26 mm

Input pressure 10 bar, regulated pressure set to 6 bar

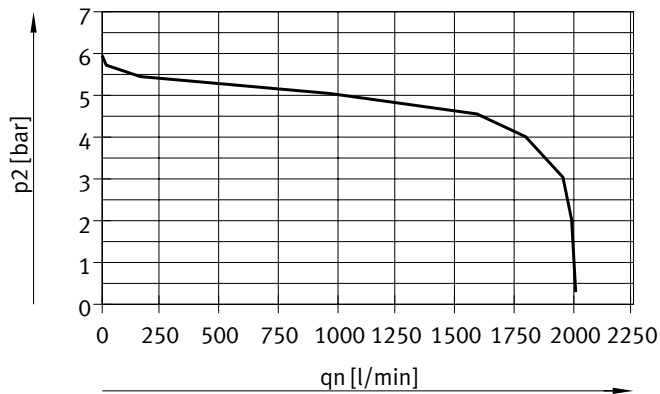

Width 42 mm (ISO 1)

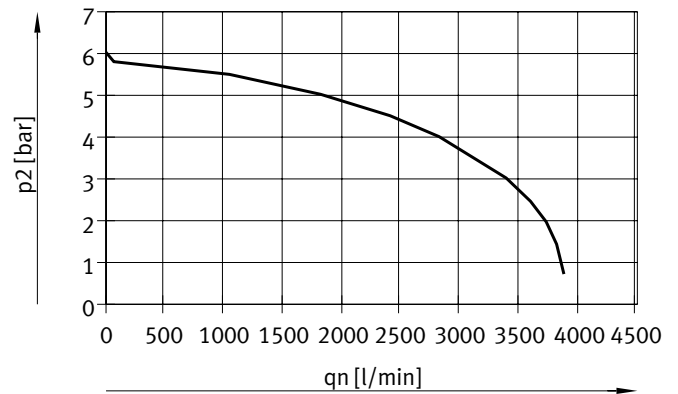

Width 52 mm (ISO 2)

Datasheet – Valve terminal

Flow rate q_N as a function of flow control

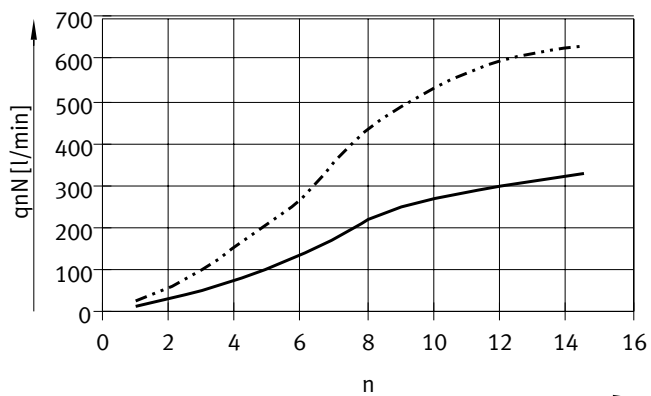

— Width 18 mm
 - - - - - Width 26 mm

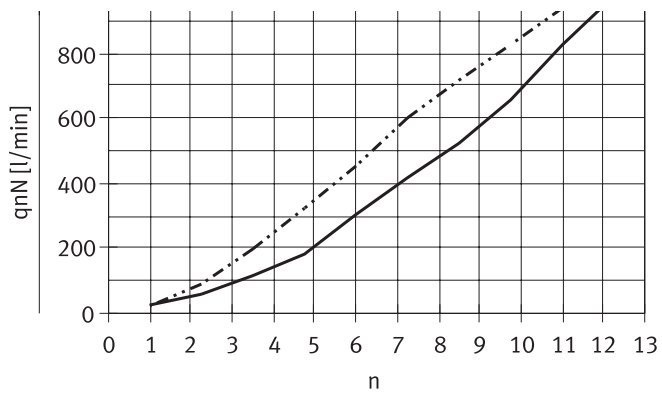

Width 42 mm (ISO 1)
 — Flow control screw from 2 → 3
 - - - - - Flow control screw from 4 → 5
 n = revolutions of the adjusting screw

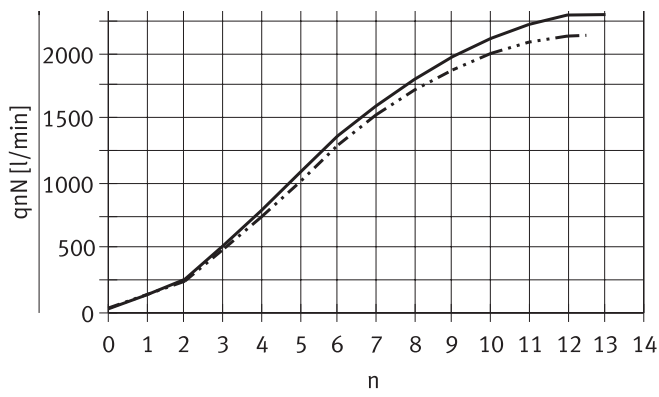

Width 52 mm (ISO 2)
 — Flow control screw from 2 → 3
 - - - - - Flow control screw from 4 → 5
 n = revolutions of the adjusting screw

Pilot pressure $p_{12/14}$ as a function of operating pressure p_1

For 3/2-way solenoid valves (T32, T22)

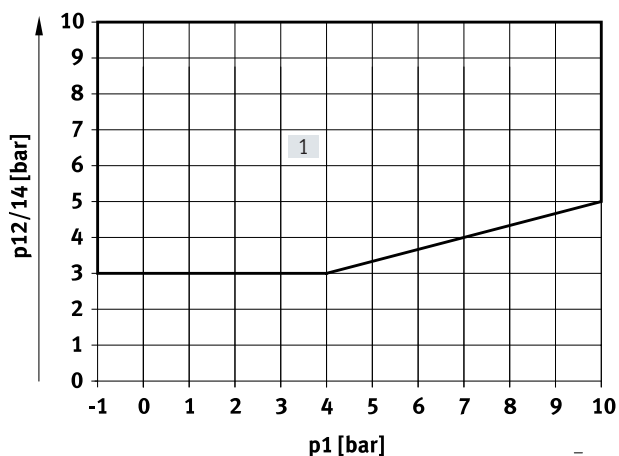

[1] Operating range for valves with external pilot air supply

For 5/2-way solenoid valves (M52, B52, D52, P53)

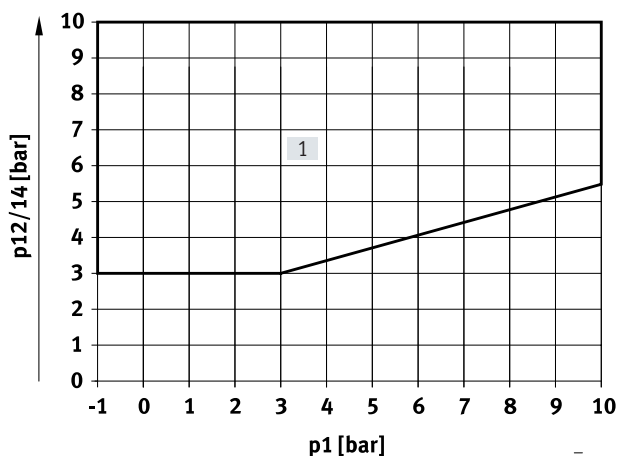

[1] Operating range for valves with external pilot air supply

Datasheet – Valve terminal

Standard nominal flow rate with vertical stacking [l/min]				
Widths	18 mm	26 mm	42 mm	52 mm
Throttle plate				
VABF-S4-2-F1B1-C	See characteristic curve	–	–	–
VABF-S4-1-F1B1-C	–	See characteristic curve	–	–
VABF-S2-1-F1B1-C	–	–	1100	–
VABF-S2-2-F1B1-C	–	–	–	See characteristic curve
Vertical supply plate				
VABF-S4-2-P1A ... -G18	430	–	–	–
VABF-S4-1-P1A ... -G14	–	900	–	–
VABF-S2-1-P1A ... -G38	–	–	1300	–
VABF-S2-2-P1A ... -G12	–	–	–	2800
Vertical pressure shut-off plate				
VABF-S4-2-L1D1-C	400	–	–	–
VABF-S4-2-L1D2-C ¹⁾	320	–	–	–
VABF-S4-1-L1D1-C	–	800	–	–
VABF-S4-1-L1D2-C ¹⁾	–	620	–	–
VABF-S2-1-L1D1-C	–	–	1200	–
VABF-S2-2-L1D1-C	–	–	–	1950

1) Lockable with key

Operating and environmental conditions	
Operating medium	Compressed air to ISO 8573-1:2010 [7:4:4]
Pilot medium	Compressed air to ISO 8573-1:2010 [7:4:4]
Notes on operating/ pilot medium	Lubricated operation possible (in which case lubricated operation will always be required)
External	[bar] –0.9 ... +10 [MPa] –0.09 ... +1
Internal	[bar] 3 ... 10 [MPa] 0.3 ... 1
Pilot pressure	[bar] 3 ... 10 [MPa] 0.3 ... 1
Noise level LpA	[dB(A)] 85
Ambient temperature	[°C] –5 ... +50
Temperature of medium	[°C] –5 ... +50
Storage temperature	[°C] –20 ... +60
Relative humidity	[%] 0 ... 90
Certification	BIA C-Tick c UL us – Recognized (OL)
CE marking (see declaration of conformity)	To EU EMC Directive 1)
KC marking	KC EMC
Corrosion resistance class CRC ²⁾	0

1) For information about the area of use, see the EC declaration of conformity at: [www.festo.com/catalogue/... d Support/Downloads](http://www.festo.com/catalogue/...d%20Support/Downloads).

If the devices are subject to usage restrictions in residential, commercial or light-industrial environments, further measures for the reduction of the emitted interference may be necessary.

2) More information www.festo.com/x/topic/crc

Datasheet – Valve terminal

Operating and environmental conditions		VTSA-MP-NPT/ VTSA-F-MP-NPT
Operating medium		Compressed air to ISO 8573-1:2010 [7:4:4]
Pilot medium		Compressed air to ISO 8573-1:2010 [7:4:4]
Notes on operating/ pilot medium		Lubricated operation possible (in which case lubricated operation will always be required)
External	[bar]	-0.9 ... +10
	[MPa]	-0.09 ... +1
Internal	[bar]	3 ... 10
	[MPa]	0.3 ... 1
Pilot pressure	[bar]	3 ... 10
	[MPa]	0.3 ... 1
Ambient temperature	[°C]	-5 ... +50
Storage temperature	[°C]	-20 ... +60
Relative humidity	[%]	0 ... 90
Certification		BIA
		C-Tick
		c UL us – Recognized (OL)
CE marking (see declaration of conformity)		To EU EMC Directive 1)
KC marking		KC EMC
Corrosion resistance class CRC ²⁾		0
Certificate-issuing authority		UL E322346

1) For information about the area of use, see the EC declaration of conformity at: [www.festo.com/catalogue/... d Support/Downloads](http://www.festo.com/catalogue/...d%20Support/Downloads).

If the devices are subject to usage restrictions in residential, commercial or light-industrial environments, further measures for the reduction of the emitted interference may be necessary.

2) More information www.festo.com/x/topic/crc

Datasheet – Valve terminal

Electrical data – Individual electrical connection		
Load voltage supply (U_{va})		
Operating voltage	[V DC]	24 ±10%
Maximum total current at 24 V DC	[A]	10
Duty cycle		100%
Degree of protection		IP65, NEMA 4 (for all types of signal transmission when mounted)

Electrical data – Multi-pin plug connection		
Load voltage supply (U_{va})		
Operating voltage	[V DC]	24 ±10%
Maximum total current	[A]	6
Current rating at 40 °C	[A]	1
Surge resistance	[kV]	1.5
Pollution degree		3
Duty cycle		100%
Degree of protection		IP65, NEMA 4 (for all types of signal transmission when mounted)

Electrical data – With CPX terminal		
Power supply for electronics ($U_{EL/SEN}$)		
Operating voltage	[V DC]	24 ±10%
Maximum intrinsic current consumption at 24 V DC	[mA]	20
Duty cycle		100%
Load voltage supply (U_{va})		
Operating voltage	[V DC]	24 ±10%
Diagnostic message undervoltage U_{OFF} load voltage outside the functional range	[V]	21.6 ... 21.5
Degree of protection		IP65, NEMA 4 (for all types of signal transmission when mounted)

Materials	
Manifold sub-base	Die-cast aluminium
Valve	Die-cast aluminium, PA
Seals	FPM, NBR, HNBR
Supply plate	Die-cast aluminium
Right end plate	Die-cast aluminium
Pneumatic interface for CPX	Die-cast aluminium
Throttle plate	Die-cast aluminium
Pressure regulator plate	Die-cast aluminium, PA
Multi-pin connection block	Die-cast aluminium
Cover for the pneumatic interface and multi-pin plug connection	PA
Note on materials	RoHS-compliant

Datasheet – Valve terminal

Product weight				
Approx. weight [g]				
Width	18 mm	26 mm	42 mm	52 mm
Multi-pin node with Sub-D or terminal strip ¹⁾	550			
Multi-pin node with M12 individual connection	760			
Pneumatic interface CPX1)	1470			
Electrical interface for AS-Interface	300			
AS-Interface module	850			
Supply plate ²⁾				
• Exhaust plate with 3 and 5 common	617			
• Exhaust air cover with 3 and 5 separate	597			
End plate, right ³⁾				
• With threaded connections	339			336
• Selector switch	281			–
Manifold sub-base ⁴⁾	447	634	340, 330 ⁵⁾	610
Angled connection plate ³⁾	170	230	176	359
Pressure regulator plate				
• For port 1 (P)	350	402	640	1190
• For port 4 or 2 (A or B)	367	448	640	1230
• For ports 4 and 2 (A/B)	611	692	920	1990
Throttle plate	228	320	220	565
Vertical supply plate ³⁾	140	191	340	605
Vertical pressure shut-off plate	209	273	600	1030
Vertical pressure shut-off plate (lockable with key)	231	290	–	–
Cover plate	34	73	68	146

1) With sheet metal seal, printed circuit board

2) With sheet metal seal and electrical link

3) With screws

4) 4) With sheet metal seal, electrical links, inscription label holder, 4 screws

5) Manifold sub-base optimised for flow rate, HS

Datasheet – Valve terminal

Dimensions

Download CAD data → www.festo.com

Valve terminal with individual electrical connection

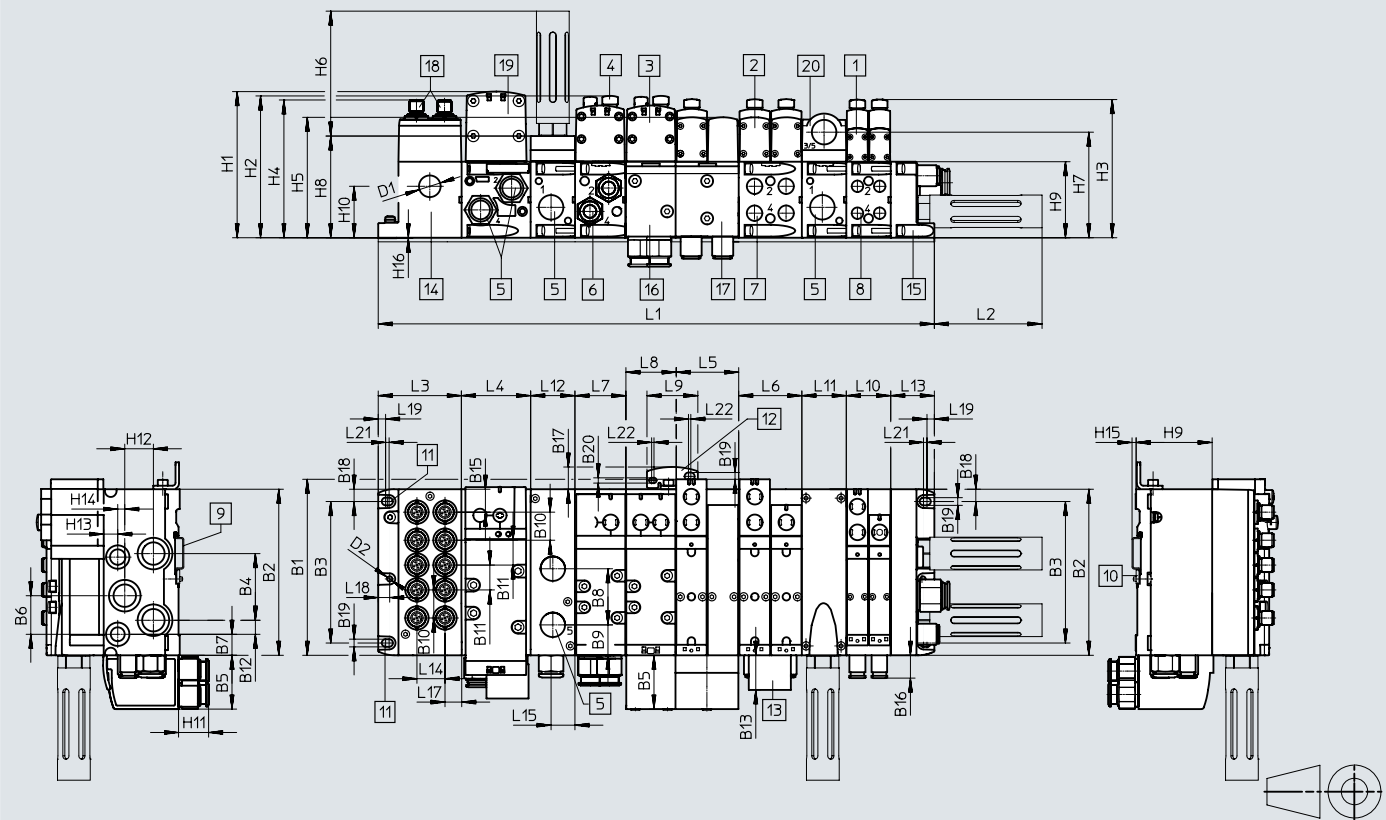

- [1] Solenoid valve, width 18 mm
- [2] Solenoid valve, width 26 mm
- [3] Solenoid valve, width 42 mm
- [4] Cover cap/manual override
- [5] Threaded connection 1/2 NPT
- [6] Threaded connection 3/8 NPT
- [7] Threaded connection 1/4 NPT
- [8] Threaded connection 1/8 NPT
- [9] DIN rail
- [10] DIN rail mounting
- [11] Mounting hole
- [12] Additional mounting bracket
- [13] Inscription label holder
- [14] Individual connection
- [15] End plate
- [16] Angled connection plate 43 mm, 3/8 NPT
- [17] Angled connection plate 54 mm, 1/4 NPT
- [18] M12 plug 5-pin (6-way or 10-way)
- [19] Solenoid valve, width 52 mm
- [20] Supply plate
- N02 Number of manifold sub-bases 38 mm
- N01 Number of manifold sub-bases 54 mm
- N1 Number of manifold sub-bases 43 mm
- N2 Number of manifold sub-bases 59 mm
- n Number of supply plates (only with end plate with pilot air selector)

Dim.	B1	B2	B3	B4	B5	B6	B7	B8	B9	B10	B11	B12	B13	B14	B15	B16	B17	B18	B19	B20
[mm]	150.5	142	121	57	46	33	18	48	26	24	21.3	12	29.6	23	19.6	19.5	19	10.5	6.6	4.5

Dim.	L2	L3	L4	L5	L6	L7	L8	L9	L10	L11	L12	L13	L14	L15	L16	L17	L18	L19
[mm]	92.4	71.3	n2x59	n01x54	54	n1x43	43	43.5	n02x38	nx38	38	37.3	24	20.5	20	14.1	9.8	6.3

Dim.	L20	L21	L22	D1Ø	D2Ø	H1	H2	H3	H4	H5	H6	H7	H8	H9	H10	H11	H12	H13	H14	H15	H16
[mm]	5.5	3	2	18.5	4.5	125	121.3	118.2	118	103	107.8	90.3	87	65	44	25.7	24.5	12	6	3.5	0.5

Width	L1
18 mm	$71.3 + n02 \times 38 + n \times 38 + 37.3$
26 mm	$71.3 + n01 \times 54 + n \times 38 + 37.3$
42 mm	$71.3 + n1 \times 43 + n \times 38 + 37.3$
52 mm	$71.3 + n2 \times 59 + n \times 38 + 37.3$
Combination of 18 mm, 26 mm, 42 mm and 52 mm	$71.3 + n02 \times 38 + n01 \times 54 + n1 \times 43 + n2 \times 59 + n \times 38 + 37.3$

† Note: This product conforms to ISO 1179-1 and ISO 228-1.

Datasheet – Valve terminal

Dimensions

Download CAD data → www.festo.com

Valve terminal with multi-pin plug connection:

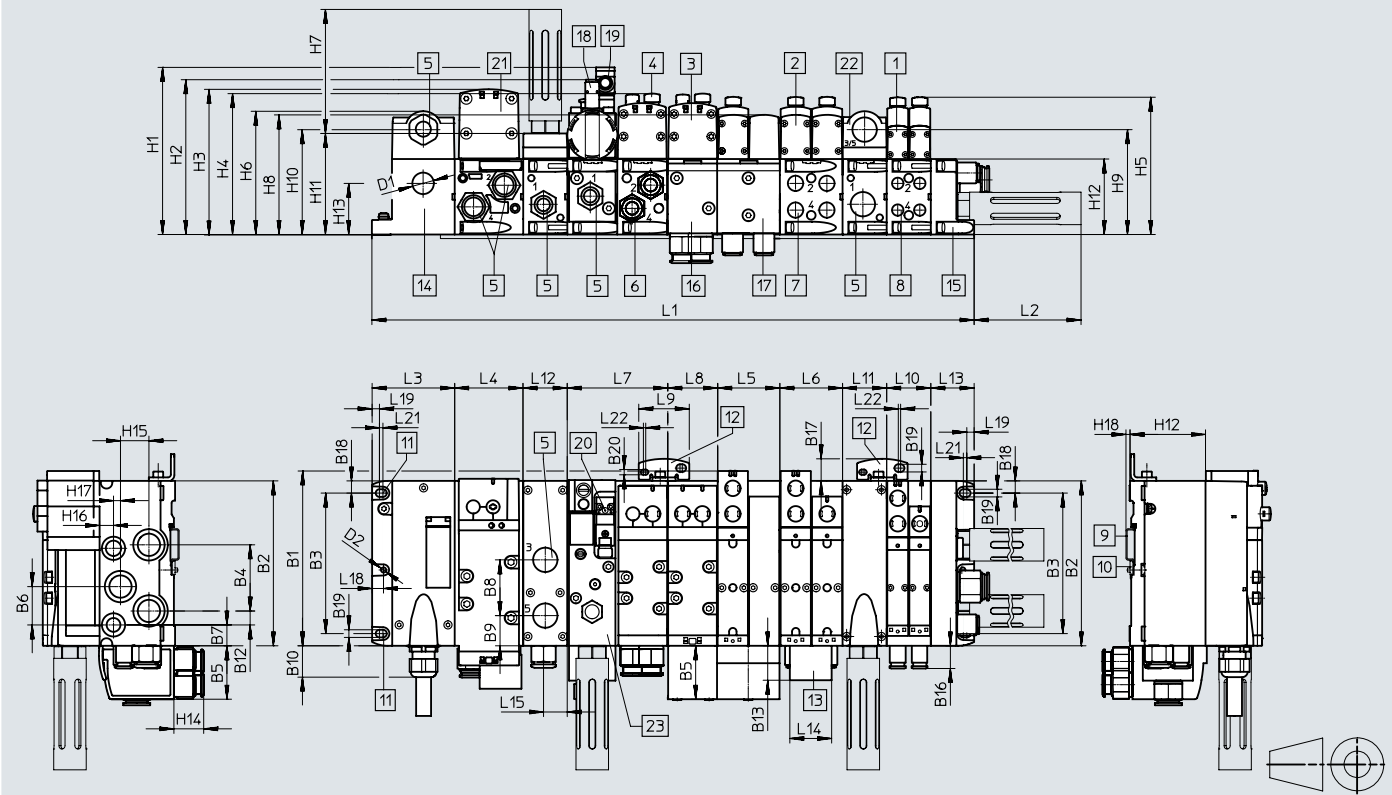

- | | | | |
|-----------------------------------|--|--|---|
| [1] Solenoid valve
Width 18 mm | [9] DIN rail | [17] Angled connection plate
54 mm, 1/4 NPT | N02 Number of manifold sub-bases 38 mm |
| [2] Solenoid valve
Width 26 mm | [10] DIN rail mounting | [18] Proximity switch M12x1 | N01 Number of manifold sub-bases 54 mm |
| [3] Solenoid valve
Width 42 mm | [11] Mounting hole | [19] Plug socket M12x1 | N1 Number of manifold sub-bases 43 mm |
| [4] Cover cap/manual override | [12] Additional mounting bracket | [20] Electrical connection to
EN 175301-803, type C | N2 Number of manifold sub-bases 59 mm |
| [5] Threaded connection 1/2 NPT | [13] Inscription label holder | [21] Solenoid valve, width 52 mm | n Number of supply plates (only with end plate with pilot air selector) |
| [6] Threaded connection 3/8 NPT | [14] Multi-pin plug connection | [22] Supply plate | |
| [7] Threaded connection 1/4 NPT | [15] End plate | [23] Soft-start valve | |
| [8] Threaded connection 1/8 NPT | [16] Angled connection plate
43 mm, 3/8 NPT | | |

Dim.	B1	B2	B3	B4	B5	B6	B7	B8	B9	B10	B11	B12	B13	B14	B16	B17	B18	B19	B20
[mm]	150.5	142	121	57	46	33	18	48	26	27	2	12	29.6	23	19.5	19	10.5	6.6	4.5

Dim.	L2	L3	L4	L5	L6	L7	L8	L9	L10	L11	L12	L13	L14	L15	L16	L18	L19	L20	L21
[mm]	92.4	71.3	n2x59	n01x54	54	n1x43	43	43.5	n02x38	nx38	38	37.3	36	20.5	20	9.8	6.3	5.5	3

Dim.	L22	D1ø	D2ø	H1	H2	H3	H4	H5	H6	H7	H8	H9	H10	H11	H12	H13	H14	H15	H16	H17	H18
[mm]	2	18.5	4.5	143.9	133.3	125	121.3	118.2	106.3	107.8	103	90.3	90.3	87	65	44	25.7	24.5	12	6	3.5

Width	L1
18 mm	$71.3 + n02 \times 38 + n \times 38 + 37.3$
26 mm	$71.3 + n01 \times 54 + n \times 38 + 37.3$
42 mm	$71.3 + n1 \times 43 + n \times 38 + 37.3$
52 mm	$71.3 + n2 \times 59 + n \times 38 + 37.3$
Combination of 18 mm, 26 mm, 42 mm and 52 mm	$71.3 + n02 \times 38 + n01 \times 54 + n1 \times 43 + n2 \times 59 + n \times 38 + 37.3$

† Note: This product conforms to ISO 1179-1 and ISO 228-1.

Datasheet – Valve terminal

Dimensions

Download CAD data → www.festo.com

Multi-pin, terminal strip (Cage Clamp), VABE-S6-1LF-C-M1-C...

Multi-pin, round plug connector, VABE-S6-1LF-C-M1-R...

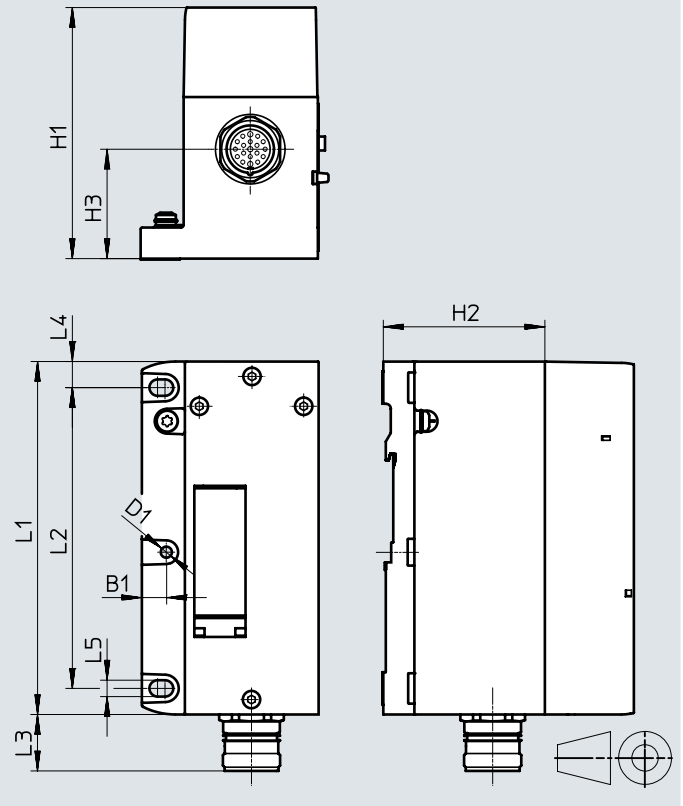
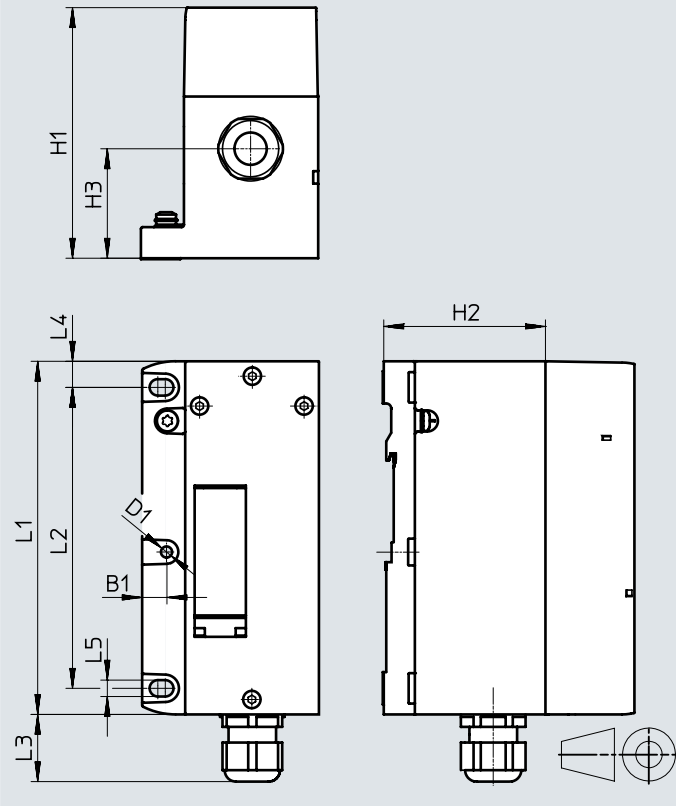

Type	H1	H2	H3	D1Ø	L1	L2	L3	L4	L5	B1
VABE-S6-1LF-C-M1-C...	106.1	65	44	4.5	142	121	27	10.5	6.6	9.8
VABE-S6-1LF-C-M1-R...	101	65	44	4.5	142	121	25	10.5	6.6	9.8

Datasheet – Valve terminal

Dimensions

Download CAD data → www.festo.com

AP interface

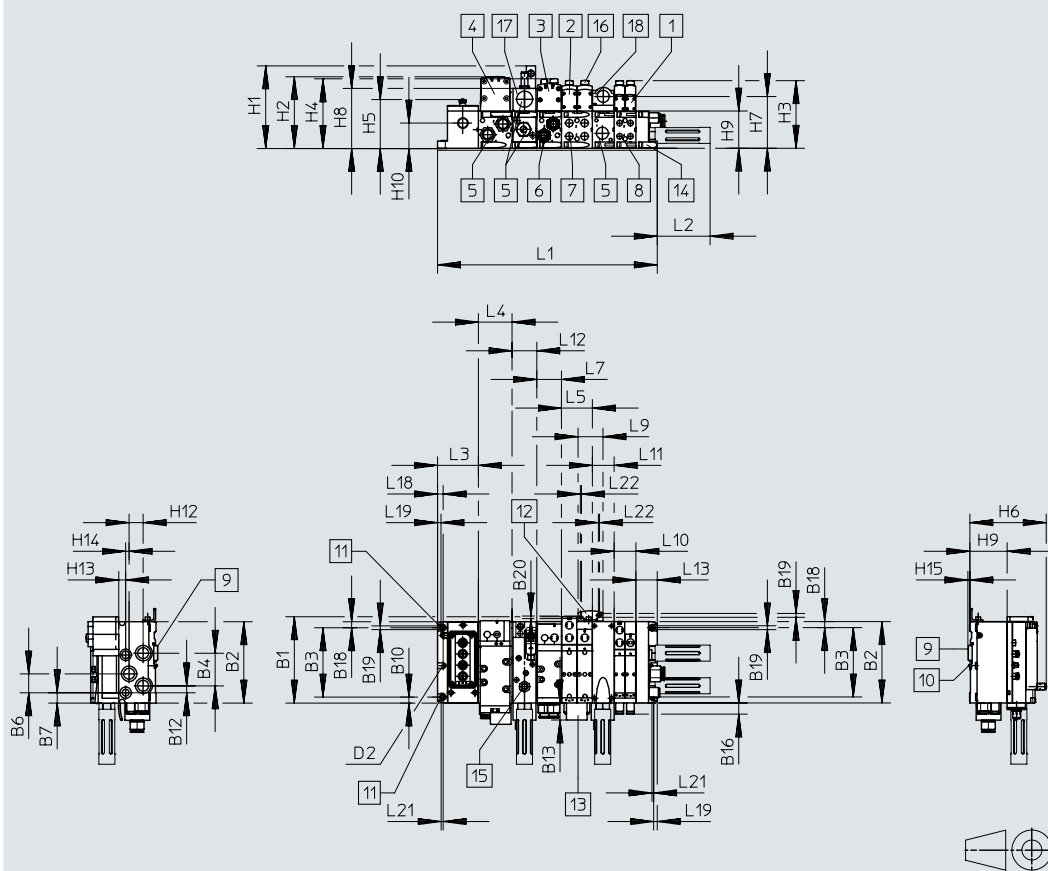

- | | | | |
|---------------------------------------|---------------------------------------|----------------------------------|--------------------------------|
| [1] Solenoid valve 18 mm | [6] Threaded connection G3/8, 3/8 NPT | [9] DIN rail | [14] End plate |
| [2] Solenoid valve 26 mm | [7] Threaded connection G1/4, 1/4 NPT | [10] DIN rail mounting | [15] Proximity switch M12x1 |
| [3] Solenoid valve 42 mm | [8] Threaded connection G1/8, 1/8 NPT | [11] Mounting hole | [16] Cover cap/manual override |
| [4] Solenoid valve 52 mm | | [12] Additional mounting bracket | [17] Soft-start valve 43 mm |
| [5] Threaded connection G1/2, 1/2 NPT | | [13] Inscription labels | [18] Supply plate |

Type	B1	B2	B3	B4	B6	B7	B10	B12	B13	B16	B18	B19	B20	D2 ∅
VTSA-ASI-...	150.5	142	121	57	33	18	28	12	29.6	19.5	10.5	6.6	4.5	4.5

Type	H1	H2	H3	H4	H5	H6	H7	H8	H9	H10	H12	H13	H14	H15
VTSA-ASI-...	143.9	125	118.2	121.3	85.5	171	90.3	104.5	65	44.4	24.5	12	6	3.5

Type	L1
Valve size 18 mm	02: 71.3 + n02 x 38 + n x 38 + 37.3
Valve size 26 mm	01: 71.3 + n01 x 54 + n x 38 + 37.3
Valve size 42 mm	71.3 + n1 x 43 + n x 38 + 37.3
Valve size 52 mm	71.3 + n2 x 59 + n x 38 + 37.3
Combination of 18 mm, 26 mm, 42 mm and 52 mm	02 + 01 + 1 + 2 71.3 + n02 x 38 + n01 x 54 + n1 x 43 + n2 x 59 + n x 38 + 37.3

Type	L2	L3	L4	L5	L7	L9	L10	L11	L12	L13	L18	L19	L21	L22
VTSA-ASI-...	92.4	71.3	n2 ¹⁾ x 59	n01 ²⁾ x 54	n1 ³⁾ x 43	43.5	n02 ⁴⁾ x 38	n ⁵⁾ x 38	43	37.3	9.8	6.3	3	2

1) Number of manifold sub-bases 59 mm
 2) Number of manifold sub-bases 54 mm
 3) Number of manifold sub-bases 43 mm
 4) Number of manifold sub-bases 38 mm
 5) Number of manifold sub-bases

Datasheet – Valve terminal

Dimensions

Download CAD data → www.festo.com

Valve terminal with AS-Interface connection

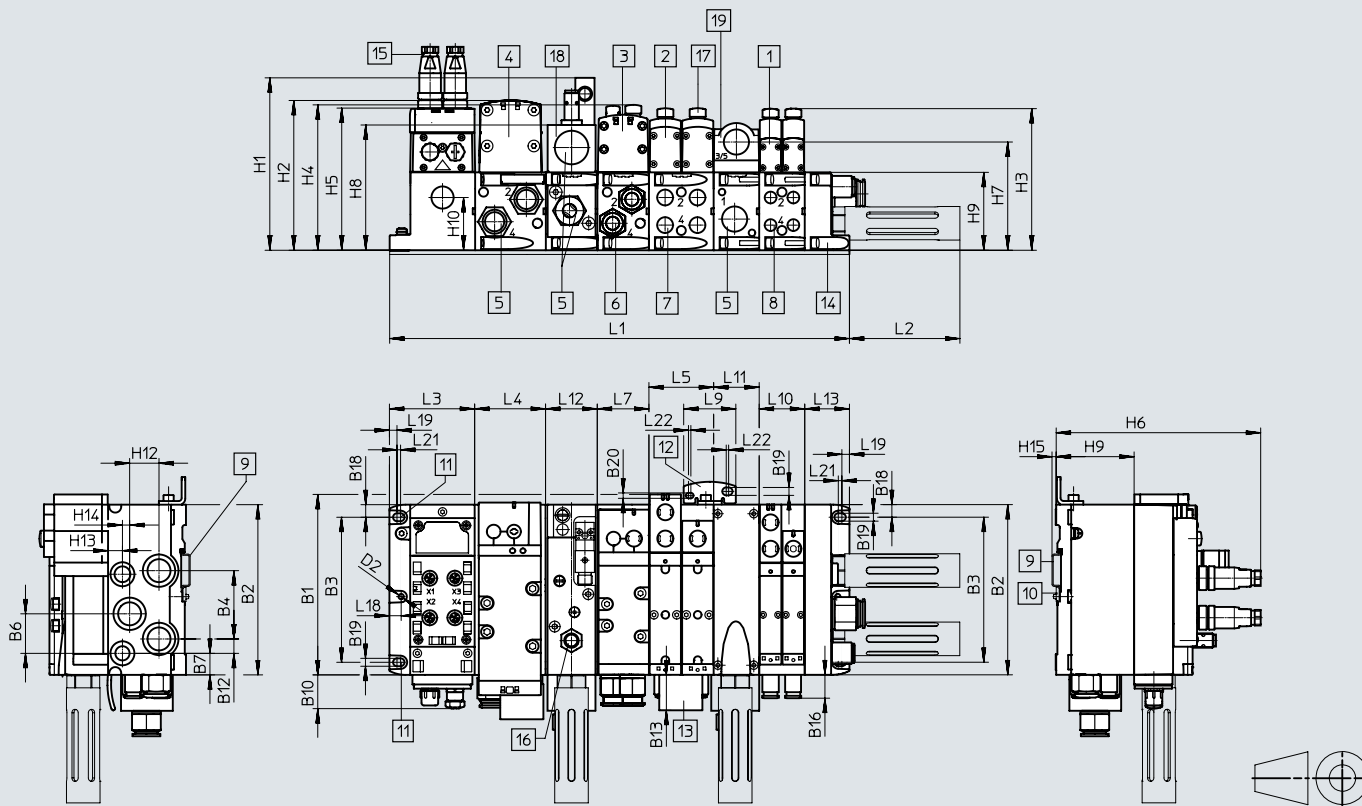

- [1] Solenoid valve, width 18 mm
- [2] Solenoid valve, width 26 mm
- [3] Solenoid valve, width 42 mm
- [4] Solenoid valve, width 52 mm
- [5] Threaded connection 1/2 NPT
- [6] Threaded connection 3/8 NPT
- [7] Threaded connection 1/4 NPT
- [8] Threaded connection 1/8 NPT
- [9] DIN rail
- [10] DIN rail mounting
- [11] Mounting hole
- [12] Additional mounting bracket
- [13] Inscription label
- [14] End plate
- [15] Plug M12
- [16] Proximity switch M12x1
- [17] Cover cap/manual override
- [18] Soft-start valve, width 43 mm
- [19] Supply plate
- N02 Number of manifold sub-bases 38 mm
- N01 Number of manifold sub-bases 54 mm
- N1 Number of manifold sub-bases 43 mm
- N2 Number of manifold sub-bases 59 mm
- n Number of supply plates

Dim.	B1	B2	B3	B4	B6	B7	B10	B12	B13	B14	B16	B18	B19	B20
[mm]	150.5	142	121	57	33	18	28	12	29.6	23	19.5	10.5	6.6	4.5

Dim.	L2	L3	L4	L5	L7	L9	L10	L11	L12	L13	L16	L18	L19	L20	L21
[mm]	92.4	71.3	n2x59	n01x54	n1x43	43.5	n02x38	nx38	43	37.3	20	9.8	6.3	5.5	3

Dim.	L22	D2ø	H1	H2	H3	H4	H5	H6	H7	H8	H9	H10	H12	H13	H14	H15
[mm]	2	4.5	143.9	125	118.2	121.3	118.6	171	90.3	104.5	65	44	24.5	12	6	3.5

Width	L1
18 mm	71.3 + n02 x 38 + n x 38 + 37.3
26 mm	71.3 + n01 x 54 + n x 38 + 37.3
42 mm	71.3 + n1 x 43 + n x 38 + 37.3
52 mm	71.3 + n2 x 59 + n x 38 + 37.3
Combination of 18 mm, 26 mm, 42 mm and 52 mm	71.3 + n02 x 38 + n01 x 54 + n1 x 43 + n2 x 59 + n x 38 + 37.3

Datasheet – Valve terminal

Dimensions

Download CAD data → www.festo.com

Valve terminal with fieldbus interface

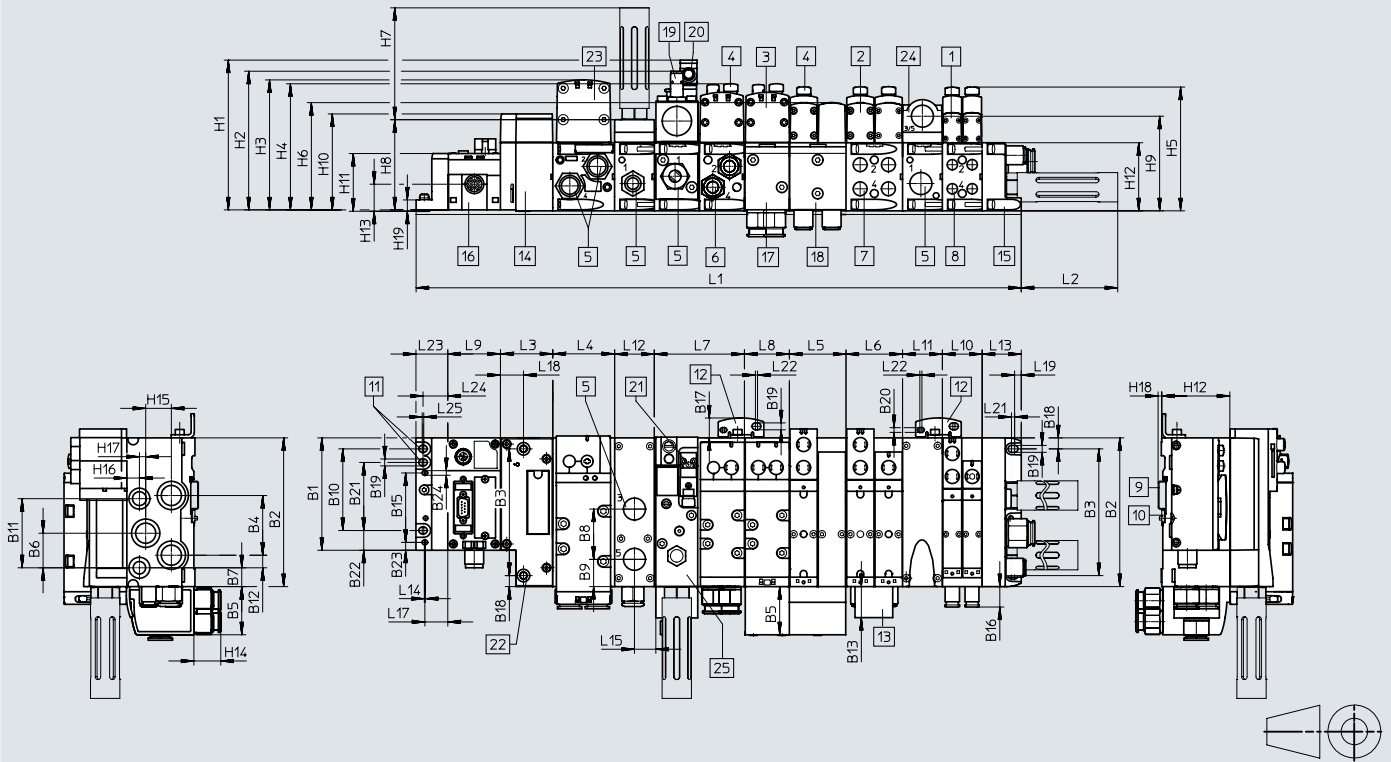

- [1] Solenoid valve, width 18 mm
- [2] Solenoid valve, width 26 mm
- [3] Solenoid valve, width 42 mm
- [4] Cover cap/manual override
- [5] Threaded connection 1/2 NPT
- [6] Threaded connection 3/8 NPT
- [7] Threaded connection 1/4 NPT
- [8] Threaded connection 1/8 NPT
- [9] DIN rail
- [10] DIN rail mounting
- [11] Mounting hole
- [12] Additional mounting bracket
- [13] Inscription label holder
- [14] Pneumatic interface CPX
- [15] End plate
- [16] CPX module/bus node
- [17] Angled connection plate 43 mm, 3/8 NPT
- [18] Angled connection plate 54 mm, 1/4 NPT
- [19] Proximity switch M12x1
- [20] Plug socket M12x1
- [21] Electrical connection to EN 175301-803, type C
- [22] Hole for additional mounting, diameter 6.4 2x
- [23] Solenoid valve, width 52 mm
- [24] Supply plate
- [25] Soft-start valve
- N02 Number of manifold sub-bases 38 mm
- N01 Number of manifold sub-bases 54 mm
- N1 Number of manifold sub-bases 43 mm
- N2 Number of manifold sub-bases 59 mm
- n Number of supply plates (only with end plate with pilot air selector)
- m Number of CPX modules

Dim.	B1	B2	B3	B4	B5	B6	B7	B8	B9	B10	B11	B12	B13	B14	B16	B17	B18	B19	B20	B21	B22	B23	B24
[mm]	107.3	142	121	57	46	33	18	48	26	78	66	12	29.6	23	19.5	19	10.5	6.6	4.5	65	18.9	7.5	4.4

Dim.	L2	L3	L4	L5	L6	L7	L8	L9	L10	L11	L12	L13	L14	L15	L17	L18	L19	L21	L22
[mm]	92.4	50	n2x59	n01x54	54	n1x43	43	mx50.1	n02x38	nx38	38	37.3	1	20.5	22	22	6.3	3	2

Dim.	L23	L24	L25	H1	H2	H3	H4	H5	H6	H7	H8	H9	H10	H11	H12	H13	H14	H15	H16	H17	H18	H19
[mm]	30.4	23.7	1.5	143.9	133.3	125	121.3	118.2	103	106.8	87	90.3	92.9	55.1	65	25.8	25.7	24.5	12	6	3.5	10.8

Width	L1
18 mm	$30.4 + m \times 50.1 + 50 + n02 \times 38 + n \times 38 + 37.3$
26 mm	$30.4 + m \times 50.1 + 50 + n01 \times 54 + n \times 38 + 37.3$
42 mm	$30.4 + m \times 50.1 + 50 + n1 \times 43 + n \times 38 + 37.3$
52 mm	$30.4 + m \times 50.1 + 50 + n2 \times 59 + n \times 38 + 37.3$
Combination of 18 mm, 26 mm, 42 mm and 52 mm	$30.4 + m \times 50.1 + 50 + n02 \times 38 + n01 \times 54 + n1 \times 43 + n2 \times 59 + n \times 38 + 37.3$

† Note: This product conforms to ISO 1179-1 and ISO 228-1.

Datasheet – Valve terminal

Dimensions

Download CAD data → www.festo.com

Vertical stacking components, width 18 mm

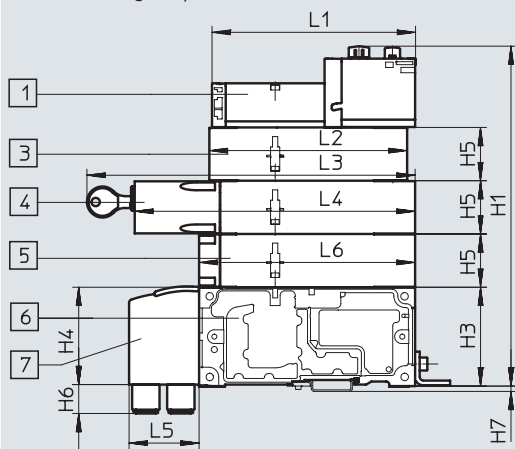

- [1] Solenoid valve with two solenoid coils, width 18 mm
- [3] Throttle plate
- [4] Vertical pressure shut-off plate lockable (code ZT), optionally lockable with key (code ZS)
- [5] Vertical supply plate
- [6] Manifold sub-base
- [7] Angled connection plate

Dim.	L1	L2	L3 (Code ZT)	L4 (Code ZT)	L3 (Code ZS)	L4 (Code ZS)	L5	L6	H1	H3	H4	H5	H6	H7
[mm]	133.8	130	-	203.7	222.3	198.3	46	142	224	65	64	35	19	3.5

Vertical stacking components, width 18 mm

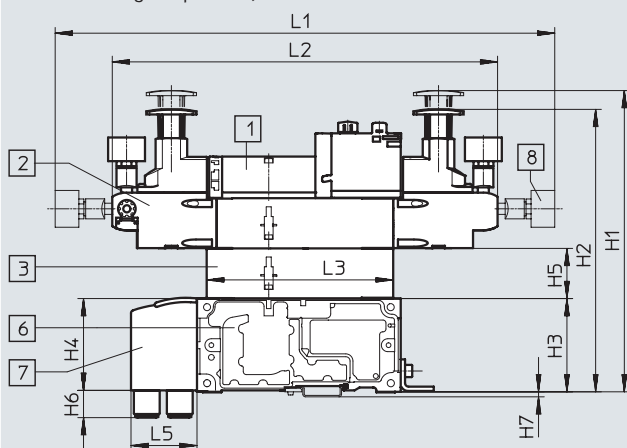

- [1] Solenoid valve with two solenoid coils, width 18 mm
- [2] Pressure regulator plate
- [3] Throttle plate
- [6] Manifold sub-base
- [7] Angled connection plate
- [8] Pressure gauge, freely positionable

Dim.	L1	L2	L3	L5	H1	H2	H3	H4	H5	H6	H7
[mm]	348.2	268.6	130	46	210	197	65	64	35	19	3.5

Vertical stacking components, width 18 mm, with the pressure regulator plate also suitable for valves with symmetrical design

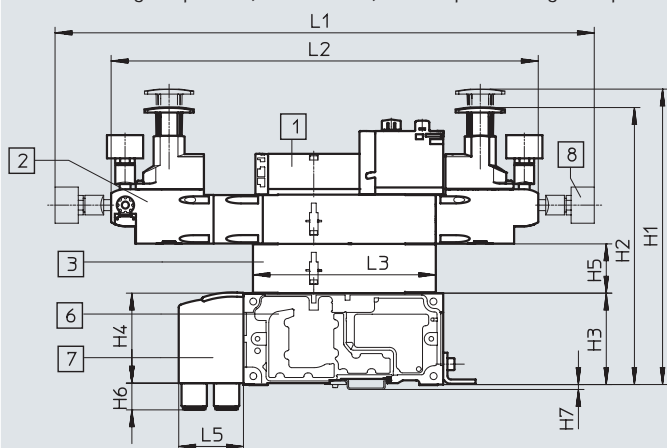

- [1] Solenoid valve with two solenoid coils, width 18 mm
- [2] Pressure regulator plate
- [3] Throttle plate
- [6] Manifold sub-base
- [7] Angled connection plate
- [8] Pressure gauge, freely positionable

Dim.	L1	L2	L3	L5	H1	H2	H3	H4	H5	H6	H7
[mm]	383.2	303.6	130	46	210	197	65	64	35	19	3.5

Datasheet – Valve terminal

Dimensions

Download CAD data → www.festo.com

Vertical stacking components, width 26 mm

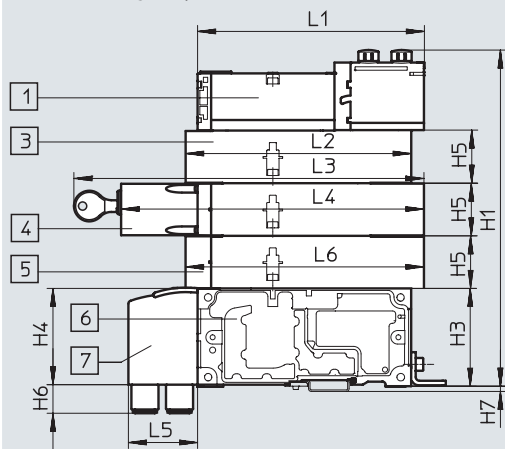

- [1] Solenoid valve with two solenoid coils, width 26 mm
- [3] Throttle plate
- [4] Vertical pressure shut-off plate, lockable (code ZT), optionally lockable with key (code ZS)
- [5] Vertical supply plate
- [6] Manifold sub-base
- [7] Angled connection plate

Dim.	L1	L2	L3 (Code ZT)	L4 (Code ZT)	L3 (Code ZS)	L4 (Code ZS)	L5	L6	H1	H3	H4	H5	H6	H7
[mm]	150.8	150	-	221	239.5	215.5	46	158.5	224	65	64	35	19	3.5

Vertical stacking components, width 26 mm

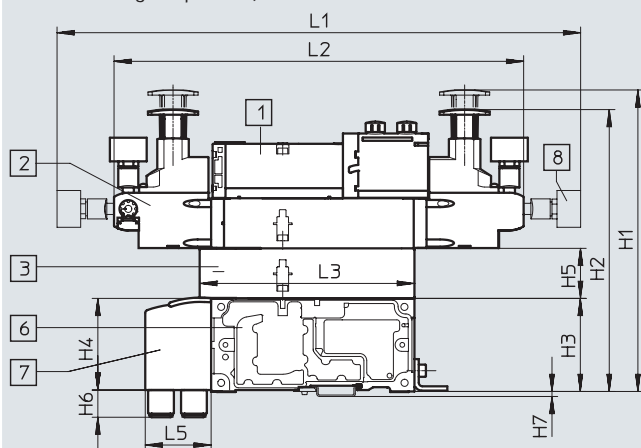

- [1] Solenoid valve with two solenoid coils, width 26 mm
- [2] Pressure regulator plate
- [3] Throttle plate
- [6] Manifold sub-base
- [7] Angled connection plate
- [8] Pressure gauge, freely positionable

Dim.	L1	L2	L3	L5	H1	H2	H3	H4	H5	H6	H7
[mm]	365.7	286.1	150	46	210	197	65	64	35	19	3.5

Vertical stacking components, width 26 mm, with the pressure regulator plate also suitable for valves with symmetrical design

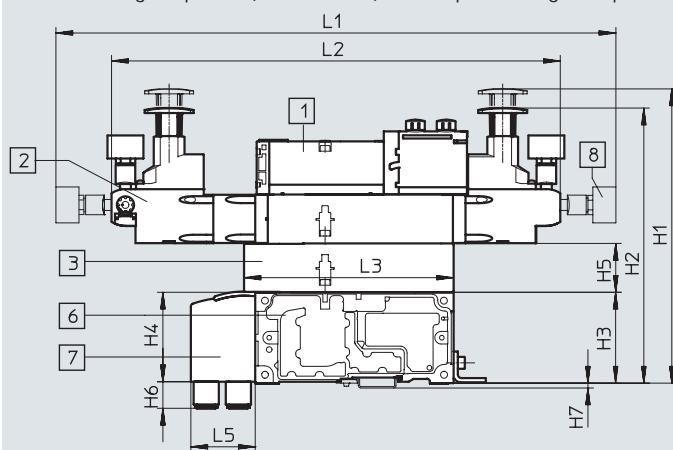

- [1] Solenoid valve with two solenoid coils, width 26 mm
- [2] Pressure regulator plate
- [3] Throttle plate
- [6] Manifold sub-base
- [7] Angled connection plate
- [8] Pressure gauge, freely positionable

Dim.	L1	L2	L3	L5	H1	H2	H3	H4	H5	H6	H7
[mm]	400.7	321.1	150	46	210	197	65	64	35	19	3.5

Datasheet – Valve terminal

Dimensions

Download CAD data → www.festo.com

Vertical stacking components, width 42 mm

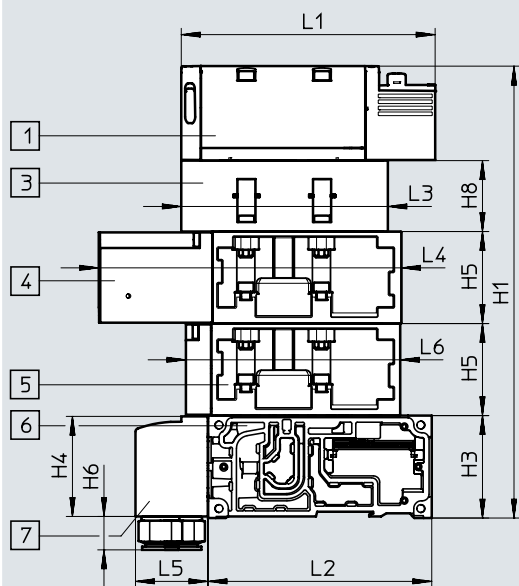

- [1] Solenoid valve
- [3] Throttle plate
- [4] Vertical pressure shut-off plate
- [5] Vertical supply plate
- [6] Manifold sub-base
- [7] Angled connection plate

Dim.	L1	L2	L3	L4	L5	L6	H1	H3	H4	H5	H6	H7	H8
[mm]	137.8	142	105.3	173.8	46	117.6	236	65	64	45.3	25.7	3.5	28

Vertical stacking components, width 42 mm

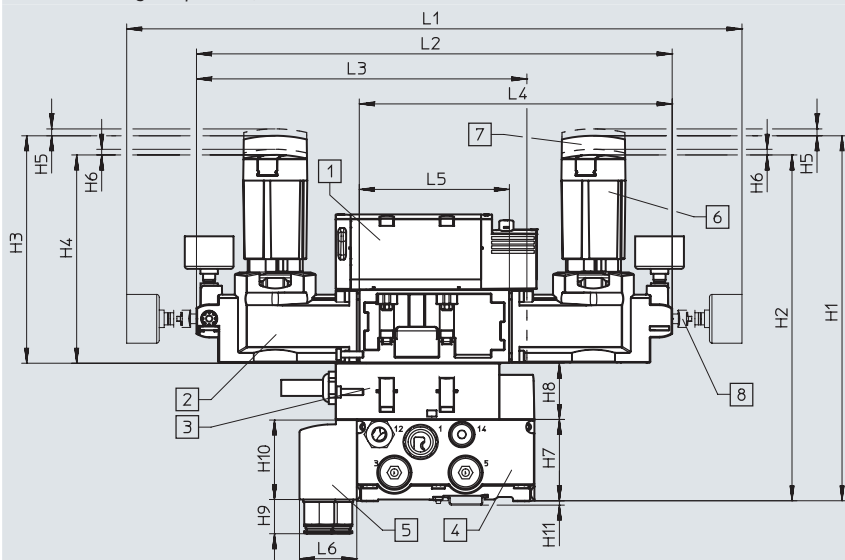

- [1] Solenoid valve
- [2] Pressure regulator plate
- [3] Throttle plate
- [4] Manifold sub-base
- [5] Angled connection plate
- [6] Short rotary knob, lockable (standard)
- [7] Long rotary knob, lockable
- [8] Pressure gauge, freely positionable

Dim.	L1	L2	L3	L4	L5	L6	H1	H2	H3	H4	H5	H6	H7	H8	H9	H10	H11
[mm]	410.3	311.6	216.1	207.1	102.6	46	220	205	127	112	3	4.2	65	28	25.7	64	3.5

Note

Pressure regulator plates for symmetrical valves with widths of 42 mm and 52 mm can only be ordered via the pressure regulator configurator VABF-S2.

→ Internet: vabf-s2

The following can be selected using the pressure regulator configurator VABF-S2:

- Rotary knob, short version with locking element (standard)
- Rotary knob, long version with locking element
- Rotary knob with integrated lock

Datasheet – Valve terminal

Dimensions

Download CAD data → www.festo.com

Vertical stacking components, width 52 mm

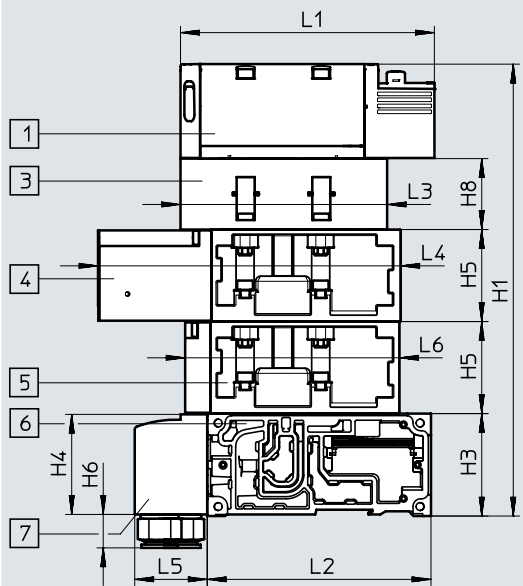

- [1] Solenoid valve
- [3] Throttle plate
- [4] Vertical pressure shut-off plate
- [5] Vertical supply plate
- [6] Manifold sub-base
- [7] Angled connection plate

Dim.	L1	L2	L3	L4	L5	L6	H1	H3	H4	H5	H6	H8
[mm]	160.7	142	131	191.2	46	136	287.4	65	63.5	58.7	21.2	45

Vertical stacking components, width 52 mm

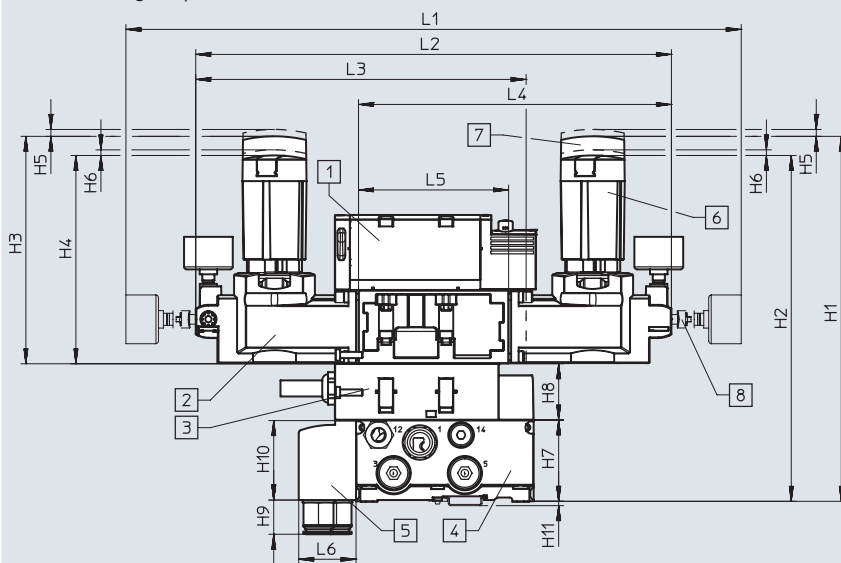

- [1] Solenoid valve
- [2] Pressure regulator plate
- [3] Throttle plate
- [4] Manifold sub-base
- [5] Angled connection plate
- [6] Short rotary knob, lockable (standard)
- [7] Long rotary knob, lockable
- [8] Pressure gauge, freely positionable

Dim.	L1	L2	L3	L4	L5	L6	H1	H2	H3	H4	H5	H6	H7	H8	H9	H10	H11
[mm]	492	380.4	264.2	250.2	120	45.8	291	276	181	166	5.5	4.5	65	45	27.4	63.5	3.5

Note

Pressure regulator plates for symmetrical valves with widths of 42 mm and 52 mm can only be ordered via the pressure regulator configurator VABF-S2.

→ Internet: vabf-s2

The following can be selected using the pressure regulator configurator VABF-S2:

- Rotary knob, short version with locking element (standard)
- Rotary knob, long version with locking element
- Rotary knob with integrated lock

Datasheet – Valve terminal

Dimensions

Download CAD data → www.festo.com

Supply plate with silencer

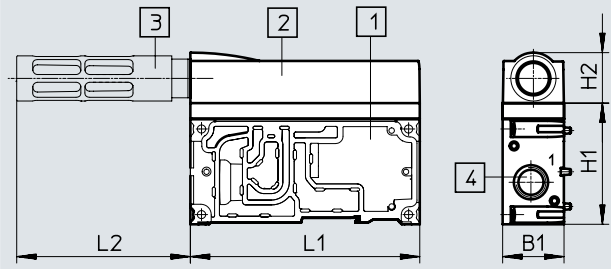

- [1] Supply plate
- [2] Exhaust port cover
- [3] Silencer U-1/2-B-NPT
- [4] Threaded connection 1/2 NPT

Dim.	L1	L2	H1	H2	B1
[mm]	142	107.5	75	31.5	38

Right end plate, VABE-S6-1R...

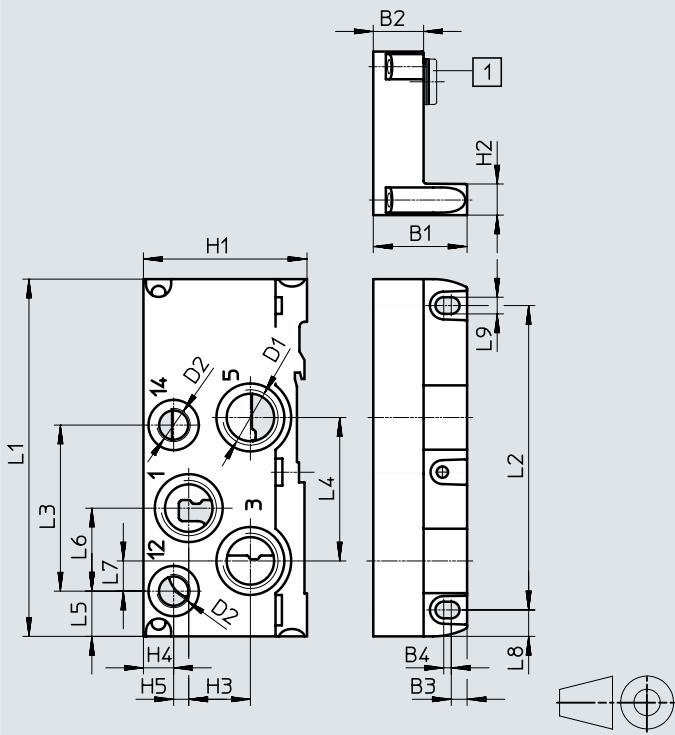

[1] Blanking plug

Right end plate, VABE-S6-2R...

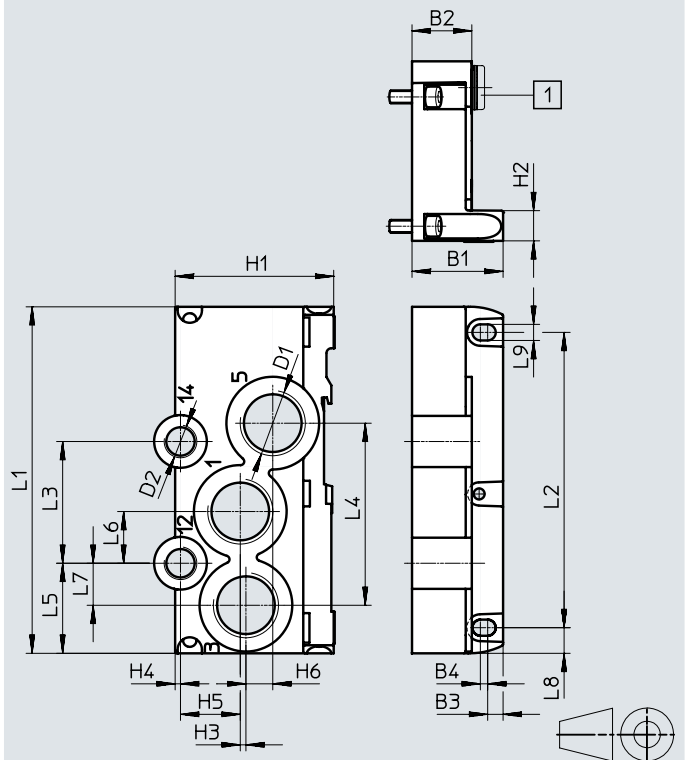

[1] Blanking plug

Type	L1	L2	L3	L4	L5	L6	L7	L8	L9	D1	D2	H1	H2	H3	H4	H5	H6	B1	B2	B3	B4	with ¹⁾
VABE-S6-1R-G12	142	121	66	57	18	33	12	10.5	6.6	1/2 NPT	1/4 NPT	65	12.5	24.5	12	6	-	37.3	22	6.3	3	[1]
VABE-S6-1RZ-G12																						-
VABE-S6-2R-G34	142	121	49.9	74.6	36.9	21.2	17.2	10.5	6.6	3/4 NPT	1/4 NPT	65	12.5	2.3	2.2	24.5	11	37.3	24.5	6.3	3	[1]
VABE-S6-2RZ-G34																						-

1) With blanking plug = internal pilot air supply, – without blanking plug = external pilot air supply
 Special feature: There is no port 14 for VABE-S6-1R-G12 (code V).

‡ Note: This product conforms to ISO 1179-1 and ISO 228-1.

Datasheet – Valve terminal

Dimensions

Download CAD data → www.festo.com

Right end plate with pilot air selector, VABE-S6-1RZ-N-B1

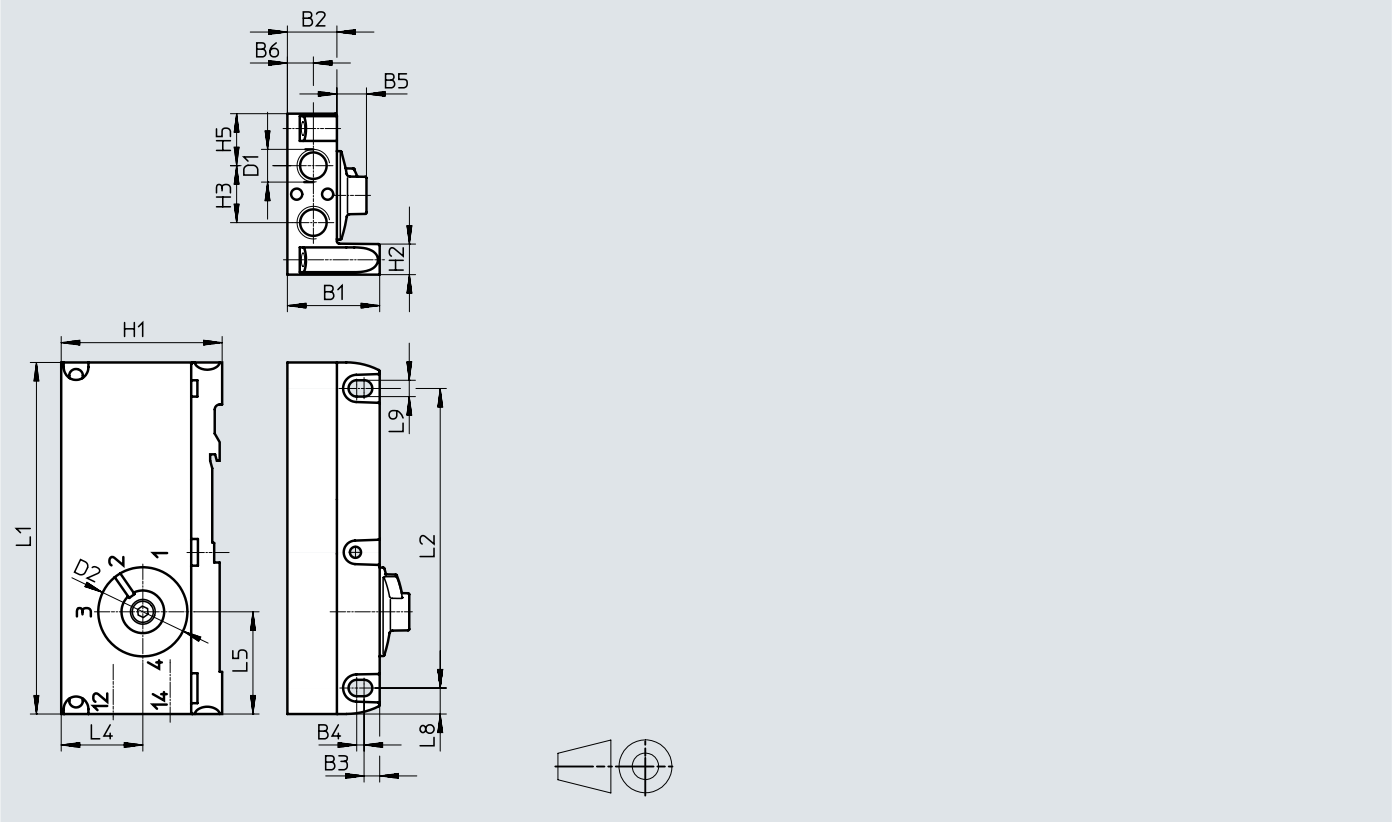

Type	L1	L2	L5	L8	L9	D1	D2	H1	H2	H3	H4	H5	B1	B2	B3	B4	B5	B6
VABE-S6-1RZ-N-B1	142	121	41.3	10.5	6.6	1/4 NPT	37	65.4	12.5	23	33	21	37.3	20	6.3	3	12	10.5

† Note: This product conforms to ISO 1179-1 and ISO 228-1.

Datasheet – Solenoid valves VSVA

-  - Valve width to ISO 15407-2
- 18 mm
 - 26 mm
- to ISO 5599-2
- 42 mm (ISO 1)
 - 52 mm (ISO 2)

-  - Voltage
24 V DC

-  - Flow rate¹⁾
- Width 18 mm: up to 550 (700) l/min
- Width 26 mm: up to 1100 (1350) l/min
- Width 42 mm: up to 1300 (1860) l/min
- Width 52 mm up to 2900 l/min

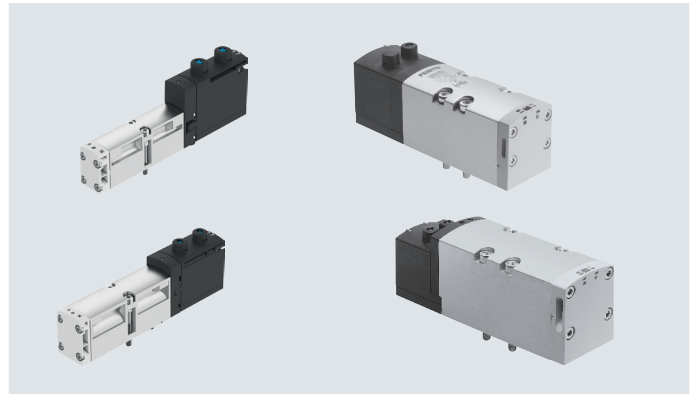

1) Flow rates in brackets apply to VTSA-F

General technical data – Solenoid valves

Design	Piston spool valve	
Sealing principle	Soft	
Overlap	Positive overlap (excluding types P53AD, P53BD)	
	Negative overlap (types P53AD, P53BD)	
Reset method	Mechanical or pneumatic, depending on the type used	
Actuation type	Electrical	
Electrical connection	Plug to ISO 15407-2, 2-pin (single solenoid types) or 4-pin (double solenoid and 5/3-way types)	
Type of control	Piloted	
Degree of protection to EN 60529	IP65, NEMA 4 (for all types of signal transmission when mounted)	
Exhaust function, can be throttled	Via individual sub-base, via throttle plate (not with valve type T22)	
Type of mounting	On manifold sub-base, on individual sub-base	
Mounting position	Any	
Manual override	Detenting, non-detenting, concealed	
Signal status indication	LED (except types with signal status display sensor, and part nos.: 560727 and 560728)	
Sensor signal status indication	Yellow LED	
Duty cycle	[%]	100
Pollution degree		3
Surge resistance	[kV]	2.5
Nominal operating voltage	[V DC]	24 (dependent on valve type)
Permissible voltage fluctuations	[%]	±10
Pneumatic connections		
Supply	1	Via the manifold sub-base of the valve terminal or via individual sub-base
Exhausting	3/5	
Working ports	2/4	
Pilot air supply	1 2/14	
Pilot exhaust air	8 2/84	Either ducted or unducted

Datasheet – Solenoid valves

Pneumatic characteristic data										
Terminal code	VC	VV	N	K	H	P	Q	R	M	O
Valve code	T22C	T22CV	T32U	T32C	T32H	T32F	T32N	T32W	M52-A	M52-M
Flow direction										
Any	–	■	–	–	–	–	–	–	■	■
Only reversible	–	–	–	–	–	■	■	■	–	–
Not reversible	■	–	■	■	■	–	–	–	–	–
Reset method										
Pneumatic spring	■	■	■	■	■	■	■	■	■	–
Mechanical spring	–	–	–	–	–	–	–	–	–	■

Pneumatic characteristic data										
Terminal code	J	D	B	G	E	SA	SB	SD	SE	VG
Valve code	B52	D52	P53U	P53C	P53E	P53ED	P53AD	P53BD	P53EP	P53F
Flow direction										
Any	■	■	■	■	■	–	■	–	–	■
Only reversible	–	–	–	–	–	–	–	–	–	–
Not reversible	–	–	–	–	–	■	–	■	■	–
Reset method										
Pneumatic spring	–	–	–	–	–	–	–	–	–	–
Mechanical spring	–	–	■	■	■	■	■	■	■	■

Flow direction of solenoid valves

Solenoid valves only with reversible flow direction

- These valves must only be operated on pressure zones with reversible supply (3 and 5 with supply pressure 1 as exhaust air) or on a reversible pressure regulator. If necessary, create separate pressure zones with duct separation.
- Reversible 3/2-way solenoid valves do not permit the special function "ducted pilot exhaust air"
- Ports 12 and 14 on the end plate variants must be supplied with the same pressure.
- Right end plate with pilot air selector: can be realised via position 1 or 2
- Right end plate with threaded connections: 12 and 14 must be supplied with the same pressure level

Solenoid valves with any flow direction

- Valves with any flow direction such as the 5/2-way solenoid valve, code M, for example, are suitable for vacuum operation (standard valves such as the 2x 2/2-way solenoid valve with code VC, for example, must not be used for vacuum operation).
- An exception is the 2x 2/2-way solenoid valve with code VV (T22CV), which only allows vacuum operation at ports 3 and 5. The solenoid valve with code VV (T22CV) cannot be combined with other valve functions; a separate pressure zone is required.

Datasheet – Solenoid valves

Operating and environmental conditions		
Operating medium		Compressed air to ISO 8573-1:2010 [7:4:4]
Pilot medium		Compressed air to ISO 8573-1:2010 [7:4:4]
Notes on operating/ Pilot medium		Lubricated operation possible (in which case lubricated operation will always be required)
Operating pressure, pilot air supply ²⁾	[bar]	-0.9 ... +10 (valves with any flow direction and reversible valves)
		3 ... 10 (non-reversible valves)
	[MPa]	-0.09 ... +1 (valves with any flow direction and reversible valves)
		0.3 ... 1 (non-reversible valves)
Pilot pressure	[bar]	3 ... 10
	[MPa]	0.3 ... 1
Pilot air supply		External
		Internal via valve terminal
Ambient temperature	[°C]	-5 ... +50
Relative humidity	[%]	0 ... 90
Certification		BIA (for characteristic SP and/or SN only)
	Direct voltage 24 V DC	C-Tick (only size 52 mm and solenoid valves with sensor (position sensing))
		c UL us – Recognized (OL)
CE marking (see declaration of conformity)	Direct voltage 24 V DC	To EU EMC Directive 1)

1) For information about the area of use, see the EC declaration of conformity at: [www.festo.com/catalogue/... d Support/Downloads](http://www.festo.com/catalogue/...d/Support/Downloads).

If the devices are subject to usage restrictions in residential, commercial or light-industrial environments, further measures for the reduction of the emitted interference may be necessary.

2) Solenoid valves with code VC (2/2-way type ... T22C), N (3/2-way type ... T32U), K (3/2-way type ... T32C), H (3/2-way type ... T32H) must not be operated with vacuum; the operating pressure here is 3 ... 10 bar

Datasheet – Solenoid valve width 18 mm

-  Valve width
to ISO 15407-2
18 mm

-  Flow rate
Valve width 18 mm:
VTSA up to 550 l/min
VTSA-F up to 700 l/min

-  Voltage
24 V DC

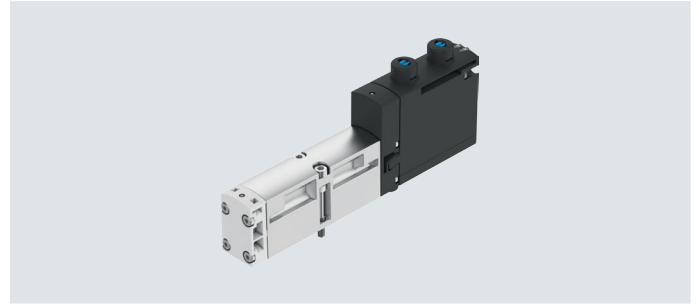
**Safety characteristics – Valve, width 18 mm**

Conforms to standard	EN 13849-1/2
CE marking (see declaration of conformity)	Direct voltage 24 V DC To EU EMC Directive 1) (solenoid valves with sensor only)
Shock resistance	Shock test with severity level 2, to EN 60068-2-27
Vibration resistant	Transport application test with severity level 2, to EN 60068-2-6

1) For information about the area of use, see the EC declaration of conformity at: [www.festo.com/catalogue/... d Support/Downloads](http://www.festo.com/catalogue/...d Support/Downloads).
If the devices are subject to usage restrictions in residential, commercial or light-industrial environments, further measures for the reduction of the emitted interference may be necessary.

Safety characteristics – Valve, width 18 mm

Valve function (with valve code)	Terminal code	Test pulses	
		Max. positive test pulse with logic 0 [µs]	Max. negative test pulse with logic 1 [µs]
5/2-way double solenoid (B52)	J	1500	800
5/2-way double solenoid with dominant signal (D52)	D	1700	1200
5/2-way single solenoid (M52A)	M	1500	800
5/2-way single solenoid (M52M)	O	1500	800
5/3-way closed (P53C)	G	1500	800
5/3-way exhausted (P53E)	E	1500	800
5/3-way pressurised (P53U)	B	1500	800
5/3-way exhausted, switching position 14 detenting (P53ED)	SA	1500	800
5/3-way exhausted, switching position 12 detenting (P53EP)	SE	1500	800
5/3-way, port 2 pressurised, 4 exhausted, switching position 14 detenting (P53AD)	SB	1500	800
5/3-way, port 4 pressurised, 2 exhausted, switching position 14 detenting (P53BD)	SD	1500	800
2x3/2-way single solenoid, closed (T32C)	K	1700	1200
2x3/2-way single solenoid, open (T32U)	N	1700	1200
2x3/2-way single solenoid, open/closed (T32H)	H	1700	1200
2x3/2-way single solenoid, closed (T32N)	Q	1700	1200
2x3/2-way single solenoid, open (T32F)	P	1700	1200
2x3/2-way single solenoid, open/closed (T32W)	R	1700	1200
2x2/2-way single solenoid, closed (T22C)	VC	1700	1200
2x2/2-way single solenoid, closed (T22CV)	VV	1700	1200

Datasheet – Solenoid valve width 18 mm

Technical data - Valve, width 18 mm							
Valve function (with valve code)	Terminal code	Flow direction			Reset method		Weight [g]
		Any	Only reversible	Not reversible	Pneumatic spring	Mechanical spring	
5/2-way double solenoid (B52)	J	■	–	–	–	–	172
5/2-way double solenoid with dominant signal (D52)	D	■	–	–	–	–	172
5/2-way single solenoid (M52A)	M	■	–	–	■	–	163
5/2-way single solenoid (M52M)	O	■	–	–	–	■	163
5/3-way closed ¹⁾ (P53C)	G	■	–	–	–	■	191
5/3-way exhausted ¹⁾ (P53E)	E	■	–	–	–	■	191
5/3-way pressurised ¹⁾ (P53U)	B	■	–	–	–	■	191
5/3-way exhausted, switching position 14 detenting (P53ED)	SA	–	–	■	–	■	170
5/3-way exhausted, switching position 12 detenting (P53EP)	SE	–	–	■	–	■	170
5/3-way, port 2 pressurised, 4 exhausted, switching position 14 detenting (P53AD)	SB	■	–	–	–	■	172
5/3-way, port 4 pressurised, 2 exhausted, switching position 14 detenting (P53BD)	SD	–	–	■	–	■	172
2x3/2-way single solenoid, closed (T32C)	K	–	–	■	■	–	190
2x3/2-way single solenoid, open (T32U)	N	–	–	■	■	–	190
2x3/2-way single solenoid, open/closed (T32H)	H	–	–	■	■	–	190
2x3/2-way single solenoid, closed (T32N)	Q	–	■	–	■	–	190
2x3/2-way single solenoid, open (T32F)	P	–	■	–	■	–	190
2x3/2-way single solenoid, open/closed (T32W)	R	–	■	–	■	–	190
2x2/2-way single solenoid, closed (T22C)	VC	–	–	■	■	–	190
2x2/2-way single solenoid, closed (T22CV)	VV	■	–	–	■	–	190

- 1) If neither solenoid coil is energised, the valve is moved to its mid-position by spring force.
If both solenoid coils are energised at the same time, the valve remains in the previously assumed switching position.

Datasheet – Solenoid valve width 18 mm

Standard nominal flow rate of valve/valve terminal [l/min], width 18 mm					
Valve function (with valve code)	Terminal code	Flow rate			
		Valve	Valve on valve terminal VTSA	Valve on valve terminal VTSA-F	Valve on individual sub-base
5/2-way double solenoid (B52)	J	750	550	700	600
5/2-way double solenoid with dominant signal (D52)	D	750	550	700	600
5/2-way single solenoid (M52A)	M	750	550	700	600
5/2-way single solenoid (M52M)	O	750	550	700	600
5/3-way closed (P53C)	G	700	450	650	550
5/3-way exhausted (P53E)	E	700 ¹⁾ 330 ²⁾	450 ¹⁾ 330 ²⁾	480 ¹⁾ 330 ²⁾	500 ¹⁾ 330 ²⁾
5/3-way pressurised (P53U)	B	700 ¹⁾ 330 ²⁾	450 ¹⁾ 330 ²⁾	480 ¹⁾ 330 ²⁾	500 ¹⁾ 330 ²⁾
5/3-way exhausted, switching position 14 detenting (P53ED)	SA	–	380 ¹⁾ 310 ²⁾	430 ¹⁾ 360 ²⁾	390 ¹⁾ 310 ²⁾
5/3-way exhausted, switching position 12 detenting (P53EP)	SE	–	380 ¹⁾ 300 ²⁾	460 ¹⁾ 350 ²⁾	390 ¹⁾ 320 ²⁾
5/3-way, port 2 pressurised, 4 exhausted, switching position 14 detenting (P53AD)	SB	–	380 ¹⁾ 350 ²⁾	440 ¹⁾ 400 ²⁾	380 ¹⁾ 360 ²⁾
5/3-way, port 4 pressurised, 2 exhausted, switching position 14 detenting (P53BD)	SD	–	370 ¹⁾ 340 ²⁾ 360 ³⁾ 360 ⁴⁾	430 ¹⁾ 360 ²⁾ 450 ³⁾ 450 ⁴⁾	400 ¹⁾ 350 ²⁾ 390 ³⁾ 380 ⁴⁾
2x3/2-way single solenoid, closed (T32C)	K	600	400	550	500
2x3/2-way single solenoid, open (T32U)	N	600	400	550	500
2x3/2-way single solenoid, open/closed (T32H)	H	600	400	550	500
2x3/2-way single solenoid, closed (T32N)	Q	600	400	550	500
2x3/2-way single solenoid, open (T32F)	P	600	400	550	500
2x3/2-way single solenoid, open/closed (T32W)	R	600	400	550	500
2x2/2-way single solenoid, closed (T22C)	VC	700	500	650	500
2x2/2-way single solenoid, closed (T22CV)	VV	700	500	650	500

- 1) Switching position
 2) Mid-position
 3) Switching position 4 → 5
 4) Mid position 2 → 3

 **Note**

When using the solenoid valves VSVA-B-P53AD-...- or VSVA-B-P53BD-...- (terminal code SB or SD) for unobstructed exhausting (1 → 2 or 1 → 4) in the detenting or mid-position, the flow rate can reduce or drop to 0 l/min if the operating pressure is greater than 6 bar. This does not happen if a tube measuring at least 15 cm in length is used at port 2/4.

Datasheet – Solenoid valve width 18 mm

Valve switching times in [ms]				
Valve function (with valve code)	Terminal code	On	Off	Changeover
5/2-way double solenoid (B52)	J	–	–	11
5/2-way double solenoid with dominant signal (D52)	D	–	–	13
5/2-way single solenoid (M52A)	M	22	28	–
5/2-way single solenoid (M52M)	O	12	38	–
5/3-way closed (P53C)	G	15	44	–
5/3-way exhausted (P53E)	E	15	44	–
5/3-way pressurised (P53U)	B	15	44	–
5/3-way exhausted, switching position 14 detenting (P53ED)	SA	13 for control side 12 10 for control side 14	37 for control side 12	(24)
5/3-way exhausted, switching position 12 detenting (P53EP)	SE	10 for control side 12 13 for control side 14	30 for control side 12	(23)
5/3-way, port 2 pressurised, 4 exhausted, switching position 14 detenting (P53AD)	SB	12 for control side 12 9 for control side 14	28 for control side 12	–
5/3-way, port 4 pressurised, 2 exhausted, switching position 14 detenting (P53BD)	SD	12 for control side 12 9 for control side 14	28 for control side 12	–
2x3/2-way single solenoid, closed (T32C)	K	12	30	–
2x3/2-way single solenoid, open (T32U)	N	12	30	–
2x3/2-way single solenoid, open/closed (T32H)	H	12	30	–
2x3/2-way single solenoid, closed (T32N)	Q	25	12	–
2x3/2-way single solenoid, open (T32F)	P	25	12	–
2x3/2-way single solenoid, open/closed (T32W)	R	25	12	–
2x2/2-way single solenoid, closed (T22C)	VC	12	30	–
2x2/2-way single solenoid, closed (T22CV)	VV	12	30	–

Characteristic coil values, width 18 mm		
Valve function (with valve code)	Terminal code	Characteristic coil values at 24 V DC in [W]
5/2-way double solenoid (B52)	J	1.6
5/2-way double solenoid with dominant signal (D52)	D	1.3
5/2-way single solenoid (M52A)	M	1.6
5/2-way single solenoid (M52M)	O	1.6
5/3-way closed (P53C)	G	1.6
5/3-way exhausted (P53E)	E	1.6
5/3-way pressurised (P53U)	B	1.6
5/3-way exhausted, switching position 14 detenting (P53ED)	SA	1.6
5/3-way exhausted, switching position 12 detenting (P53EP)	SE	1.6
5/3-way, port 2 pressurised, 4 exhausted, switching position 14 detenting (P53AD)	SB	1.6
5/3-way, port 4 pressurised, 2 exhausted, switching position 14 detenting (P53BD)	SD	1.6
2x3/2-way single solenoid, closed (T32C)	K	1.3
2x3/2-way single solenoid, open (T32U)	N	1.3
2x3/2-way single solenoid, open/closed (T32H)	H	1.3
2x3/2-way single solenoid, closed (T32N)	Q	1.3
2x3/2-way single solenoid, open (T32F)	P	1.3
2x3/2-way single solenoid, open/closed (T32W)	R	1.3
2x2/2-way single solenoid, closed (T22C)	VC	1.3
2x2/2-way single solenoid, closed (T22CV)	VV	1.3

Materials	
Housing	Die-cast aluminium, PA
Seals	FPM, NBR, HNBR
Screws	Galvanised steel
Note on materials	RoHS-compliant

Ordering data – Solenoid valve

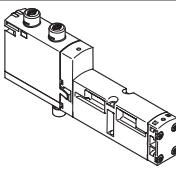
Ordering data – Solenoid valve VSVA, MO non-detenting/detenting (D)						
	Terminal code	Valve function	Valve code	Width	Part no.	Type
Solenoid valves						
	VC	2x 2/2-way valve, single solenoid, normally closed, pneumatic spring return	T22C	18 mm	561155	VSVA-B-T22C-AZD-A2-1T1L
	VV	2x 2/2-way valve, single solenoid, normally closed, Pneumatic spring return, vacuum operation possible at 3 and 5	T22CV	18 mm	561159	VSVA-B-T22CV-AZD-A2-1T1L
	N	2x 3/2-way valve, single solenoid, Normally open	T32U	18 mm	539178	VSVA-B-T32U-AZD-A2-1T1L
	K	2x 3/2-way valve, single solenoid, Normally closed	T32C	18 mm	539176	VSVA-B-T32C-AZD-A2-1T1L
	H	2x 3/2-way valve, single solenoid, 1x normally open, 1x normally closed	T32H	18 mm	539180	VSVA-B-T32H-AZD-A2-1T1L
	P	2x 3/2-way valve, single solenoid, reverse operation, Normally open	T32F	18 mm	539179	VSVA-B-T32F-AZD-A2-1T1L
	Q	2x 3/2-way valve, single solenoid, reverse operation, Normally closed	T32N	18 mm	539177	VSVA-B-T32N-AZD-A2-1T1L
	R	2x 3/2-way valve, single solenoid, reverse operation, 1x normally open, 1x normally closed	T32W	18 mm	539181	VSVA-B-T32W-AZD-A2-1T1L
	M	5/2-way valve, single solenoid, pneumatic spring return	M52-A	18 mm	539184	VSVA-B-M52-AZD-A2-1T1L
	O	5/2-way valve, single solenoid, mechanical spring return	M52-M	18 mm	539185	VSVA-B-M52-MZD-A2-1T1L
	J	5/2-way valve, double solenoid	B52	18 mm	539182	VSVA-B-B52-ZD-A2-1T1L
	D	5/2-way valve, double solenoid, with dominant signal	D52	18 mm	539183	VSVA-B-D52-ZD-A2-1T1L
	B	5/3-way solenoid valve, Mid-position pressurised	P53U	18 mm	539186	VSVA-B-P53U-ZD-A2-1T1L
	G	5/3-way solenoid valve, mid-position closed	P53C	18 mm	539188	VSVA-B-P53C-ZD-A2-1T1L
	E	5/3-way solenoid valve, mid-position exhausted	P53E	18 mm	539187	VSVA-B-P53E-ZD-A2-1T1L
	SA	5/3-way solenoid valve, mid-position exhausted, switching position 14 detenting, mechanical spring return	P53ED	18 mm	8031814	VSVA-B-P53ED-ZD-A2-1T1L
	SE	5/3-way solenoid valve, mid-position exhausted, switching position 12 detenting, mechanical spring return	P53EP	18 mm	8031818	VSVA-B-P53EP-ZD-A2-1T1L
SB	5/3-way solenoid valve, mid-position 1x exhausted from 4 to 5, 1x pressurised from 1 to 2, switching position 14 detenting, same function in both switching positions: pressurised from 1 to 4 and exhausted from 2 to 3, mechanical spring return	P53AD	18 mm	8031815	VSVA-B-P53AD-ZD-A2-1T1L	
SD	5/3-way solenoid valve, mid-position 1x exhausted from 2 to 3, 1x pressurised from 1 to 4, switching position 14 detenting, same function in both switching positions: pressurised from 1 to 2 and exhausted from 4 to 5, mechanical spring return	P53BD	18 mm	8031817	VSVA-B-P53BD-ZD-A2-1T1L	

Ordering data – Solenoid valve

Ordering data – Solenoid valve VSVA with cover cap for MO non-detenting/heavy duty, detenting via accessory (TR)

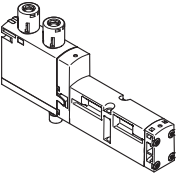
	Terminal code	Valve function	Valve code	Width	Part no.	Type
Solenoid valves						
	VC	2x 2/2-way valve, single solenoid, normally closed, pneumatic spring return	T22C	18 mm	8033457	VSVA-B-T22C-AZTR-A2-1T1L
	VV	2x 2/2-way valve, single solenoid, normally closed, pneumatic spring return, vacuum operation possible at 3 and 5	T22CV	18 mm	8033458	VSVA-B-T22CV-AZTR-A2-1T1L
	N	2x 3/2-way valve, single solenoid, normally open	T32U	18 mm	8033446	VSVA-B-T32U-AZTR-A2-1T1L
	K	2x 3/2-way valve, single solenoid, normally closed	T32C	18 mm	8033444	VSVA-B-T32C-AZTR-A2-1T1L
	H	2x 3/2-way valve, single solenoid, 1x normally open, 1x normally closed	T32H	18 mm	8033448	VSVA-B-T32H-AZTR-A2-1T1L
	P	2x 3/2-way valve, single solenoid, reverse operation, normally open	T32F	18 mm	8033447	VSVA-B-T32F-AZTR-A2-1T1L
	Q	2x 3/2-way valve, single solenoid, reverse operation, normally closed	T32N	18 mm	8033445	VSVA-B-T32N-AZTR-A2-1T1L
	R	2x 3/2-way valve, single solenoid, reverse operation, 1x normally open, 1x normally closed	T32W	18 mm	8033449	VSVA-B-T32W-AZTR-A2-1T1L
	M	5/2-way valve, single solenoid, pneumatic spring return	M52-A	18 mm	8033452	VSVA-B-M52-AZTR-A2-1T1L
	O	5/2-way valve, single solenoid, mechanical spring return	M52-M	18 mm	8033453	VSVA-B-M52-MZTR-A2-1T1L
	J	5/2-way valve, double solenoid	B52	18 mm	8033450	VSVA-B-B52-ZTR-A2-1T1L
	D	5/2-way valve, double solenoid, with dominant signal	D52	18 mm	8033451	VSVA-B-D52-ZTR-A2-1T1L
	B	5/3-way solenoid valve, mid-position pressurised	P53U	18 mm	8033454	VSVA-B-P53U-ZTR-A2-1T1L
	G	5/3-way solenoid valve, mid-position closed	P53C	18 mm	8033456	VSVA-B-P53C-ZTR-A2-1T1L
	E	5/3-way solenoid valve, mid-position exhausted	P53E	18 mm	8033455	VSVA-B-P53E-ZTR-A2-1T1L
	SA	5/3-way solenoid valve, mid-position exhausted, switching position 14 detenting, mechanical spring return	P53ED	18 mm	8039181	VSVA-B-P53ED-ZTR-A2-1T1L
	SE	5/3-way solenoid valve, mid-position exhausted, switching position 12 detenting, mechanical spring return	P53EP	18 mm	8039190	VSVA-B-P53EP-ZTR-A2-1T1L
SB	5/3-way solenoid valve, mid-position 1x exhausted from 4 to 5, 1x pressurised from 1 to 2, switching position 14 detenting, same function in both switching positions: pressurised from 1 to 4 and exhausted from 2 to 3, mechanical spring return	P53AD	18 mm	8039184	VSVA-B-P53AD-ZTR-A2-1T1L	
SD	5/3-way solenoid valve, mid-position 1x exhausted from 2 to 3, 1x pressurised from 1 to 4, switching position 14 detenting, same function in both switching positions: pressurised from 1 to 2 and exhausted from 4 to 5, mechanical spring return	P53BD	18 mm	8040110	VSVA-B-P53BD-ZTR-A2-1T1L	

Ordering data – Solenoid valve

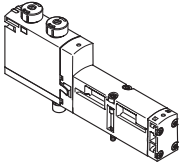
Ordering data – Solenoid valve VSVA with cover cap for MO, non-detenting (H)						
	Terminal code	Valve function	Valve code	Width	Part no.	Type
Solenoid valves						
	VC	2x 2/2-way valve, single solenoid, normally closed, pneumatic spring return	T22C	18 mm	8033475	VSVA-B-T22C-AZH-A2-1T1L
	VV	2x 2/2-way valve, single solenoid, normally closed, pneumatic spring return, vacuum operation possible at 3 and 5	T22CV	18 mm	8033476	VSVA-B-T22CV-AZH-A2-1T1L
	N	2x 3/2-way valve, single solenoid, normally open	T32U	18 mm	8033464	VSVA-B-T32U-AZH-A2-1T1L
	K	2x 3/2-way valve, single solenoid, Normally closed	T32C	18 mm	8033462	VSVA-B-T32C-AZH-A2-1T1L
	H	2x 3/2-way valve, single solenoid, 1x normally open, 1x normally closed	T32H	18 mm	8033466	VSVA-B-T32H-AZH-A2-1T1L
	P	2x 3/2-way valve, single solenoid, reverse operation, normally open	T32F	18 mm	8033465	VSVA-B-T32F-AZH-A2-1T1L
	Q	2x 3/2-way valve, single solenoid, reverse operation, normally closed	T32N	18 mm	8033463	VSVA-B-T32N-AZH-A2-1T1L
	R	2x 3/2-way valve, single solenoid, reverse operation, 1x normally open, 1x normally closed	T32W	18 mm	8033467	VSVA-B-T32W-AZH-A2-1T1L
	M	5/2-way valve, single solenoid, pneumatic spring return	M52-A	18 mm	8033470	VSVA-B-M52-AZH-A2-1T1L
	O	5/2-way valve, single solenoid, mechanical spring return	M52-M	18 mm	8033471	VSVA-B-M52-MZH-A2-1T1L
	J	5/2-way valve, double solenoid	B52	18 mm	8033468	VSVA-B-B52-ZH-A2-1T1L
	D	5/2-way valve, double solenoid, with dominant signal	D52	18 mm	8033469	VSVA-B-D52-ZH-A2-1T1L
	B	5/3-way solenoid valve, mid-position pressurised	P53U	18 mm	8033472	VSVA-B-P53U-ZH-A2-1T1L
	G	5/3-way solenoid valve, mid-position closed	P53C	18 mm	8033474	VSVA-B-P53C-ZH-A2-1T1L
	E	5/3-way solenoid valve, mid-position exhausted	P53E	18 mm	8033473	VSVA-B-P53E-ZH-A2-1T1L
	SA	5/3-way solenoid valve, mid-position exhausted, switching position 14 detenting, mechanical spring return	P53ED	18 mm	8039182	VSVA-B-P53ED-ZH-A2-1T1L
	SE	5/3-way solenoid valve, mid-position exhausted, switching position 12 detenting, mechanical spring return	P53EP	18 mm	8039191	VSVA-B-P53EP-ZH-A2-1T1L
SB	5/3-way solenoid valve, mid-position 1x exhausted from 4 to 5, 1x pressurised from 1 to 2, switching position 14 detenting, same function in both switching positions: pressurised from 1 to 4 and exhausted from 2 to 3, mechanical spring return	P53AD	18 mm	8039185	VSVA-B-P53AD-ZH-A2-1T1L	
SD	5/3-way solenoid valve, mid-position 1x exhausted from 2 to 3, 1x pressurised from 1 to 4, switching position 14 detenting, same function in both switching positions: pressurised from 1 to 2 and exhausted from 4 to 5, mechanical spring return	P53BD	18 mm	8040111	VSVA-B-P53BD-ZH-A2-1T1L	

Ordering data – Solenoid valve

Ordering data – Solenoid valve VSVA with cover cap for MO, concealed

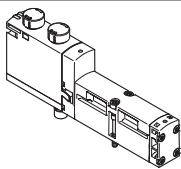
	Terminal code	Valve function	Valve code	Width	Part no.	Type
Solenoid valves						
	VC	2x 2/2-way valve, single solenoid, normally closed, pneumatic spring return	T22C	18 mm	8033493	VSVA-B-T22C-AZ-A2-1T1L
	VV	2x 2/2-way valve, single solenoid, normally closed, pneumatic spring return, vacuum operation possible at 3 and 5	T22CV	18 mm	8033494	VSVA-B-T22CV-AZ-A2-1T1L
	N	2x 3/2-way valve, single solenoid, normally open	T32U	18 mm	8033482	VSVA-B-T32U-AZ-A2-1T1L
	K	2x 3/2-way valve, single solenoid, normally closed	T32C	18 mm	8033480	VSVA-B-T32C-AZ-A2-1T1L
	H	2x 3/2-way valve, single solenoid, 1x normally open, 1x normally closed	T32H	18 mm	8033484	VSVA-B-T32H-AZ-A2-1T1L
	P	2x 3/2-way valve, single solenoid, reverse operation, normally open	T32F	18 mm	8033483	VSVA-B-T32F-AZ-A2-1T1L
	Q	2x 3/2-way valve, single solenoid, reverse operation, normally closed	T32N	18 mm	8033481	VSVA-B-T32N-AZ-A2-1T1L
	R	2x 3/2-way valve, single solenoid, reverse operation, 1x normally open, 1x normally closed	T32W	18 mm	8033485	VSVA-B-T32W-AZ-A2-1T1L
	M	5/2-way valve, single solenoid, Pneumatic spring return	M52-A	18 mm	8033488	VSVA-B-M52-AZ-A2-1T1L
	O	5/2-way valve, single solenoid, mechanical spring return	M52-M	18 mm	8033489	VSVA-B-M52-MZ-A2-1T1L
	J	5/2-way valve, double solenoid	B52	18 mm	8033486	VSVA-B-B52-Z-A2-1T1L
	D	5/2-way valve, double solenoid, with dominant signal	D52	18 mm	8033487	VSVA-B-D52-Z-A2-1T1L
	B	5/3-way solenoid valve, mid-position pressurised	P53U	18 mm	8033490	VSVA-B-P53U-Z-A2-1T1L
	G	5/3-way solenoid valve, mid-position closed	P53C	18 mm	8033492	VSVA-B-P53C-Z-A2-1T1L
	E	5/3-way solenoid valve, mid-position exhausted	P53E	18 mm	8033491	VSVA-B-P53E-Z-A2-1T1L
	SA	5/3-way solenoid valve, mid-position exhausted, switching position 14 detenting, mechanical spring return	P53ED	18 mm	8039183	VSVA-B-P53ED-Z-A2-1T1L
	SE	5/3-way solenoid valve, mid-position exhausted, switching position 12 detenting, mechanical spring return	P53EP	18 mm	8039192	VSVA-B-P53EP-Z-A2-1T1L
SB	5/3-way solenoid valve, mid-position 1x exhausted from 4 to 5, 1x pressurised from 1 to 2, switching position 14 detenting, same function in both switching positions: pressurised from 1 to 4 and exhausted from 2 to 3, mechanical spring return	P53AD	18 mm	8039186	VSVA-B-P53AD-Z-A2-1T1L	
SD	5/3-way solenoid valve, mid-position 1x exhausted from 2 to 3, 1x pressurised from 1 to 4, switching position 14 detenting, same function in both switching positions: pressurised from 1 to 2 and exhausted from 4 to 5, mechanical spring return	P53BD	18 mm	8040112	VSVA-B-P53BD-Z-A2-1T1L	

Datasheet – Solenoid valve width 26 mm

-  Valve width
to ISO 15407-2
26 mm

-  Flow rate
Valve width 26 mm:
VTSA up to 1100 l/min
VTSA-F up to 1350 l/min

-  Voltage
24 V DC

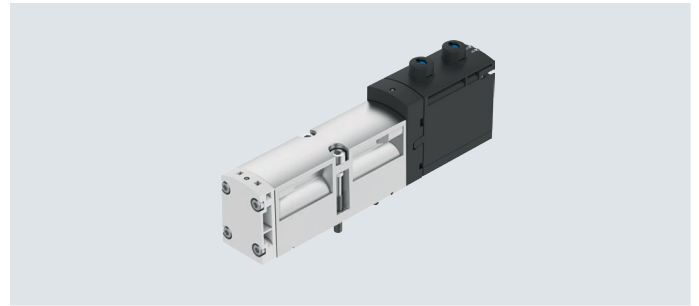
**Safety characteristics – Valve, width 26 mm**

Conforms to standard	EN 13849-1/2
CE marking (see declaration of conformity)	Direct voltage 24 V DC To EU EMC Directive 1) (solenoid valves with sensor only)
Shock resistance	Shock test with severity level 2, to EN 60068-2-27
Vibration resistant	Transport application test with severity level 2, to EN 60068-2-6

1) For information about the area of use, see the EC declaration of conformity at: [www.festo.com/catalogue/... d Support/Downloads](http://www.festo.com/catalogue/...d Support/Downloads).
If the devices are subject to usage restrictions in residential, commercial or light-industrial environments, further measures for the reduction of the emitted interference may be necessary.

Safety characteristics – Valve, width 26 mm

Valve function (with valve code)	Terminal code	Test pulses	
		Max. positive test pulse with logic 0 [μ s]	Max. negative test pulse with logic 1 [μ s]
5/2-way double solenoid (B52)	J	1200	1100
5/2-way double solenoid with dominant signal (D52)	D	1200	1100
5/2-way single solenoid (M52A)	M	1200	1100
5/2-way single solenoid (M52M)	O	1200	1100
5/3-way closed (P53C)	G	1200	1100
5/3-way exhausted (P53E)	E	1200	1100
5/3-way pressurised (P53U)	B	1200	1100
5/3-way exhausted, switching position 14 detenting (P53ED)	SA	1200	1100
5/3-way exhausted, switching position 12 detenting (P53EP)	SE	1200	1100
5/3-way, port 2 pressurised, 4 exhausted, switching position 14 detenting (P53AD)	SB	1200	1100
5/3-way, port 4 pressurised, 2 exhausted, switching position 14 detenting (P53BD)	SD	1200	1100
2x3/2-way single solenoid, closed (T32C)	K	1500	1200
2x3/2-way single solenoid, open (T32U)	N	1500	1200
2x3/2-way single solenoid, open/closed (T32H)	H	1500	1200
2x3/2-way single solenoid, closed (T32N)	Q	1500	1200
2x3/2-way single solenoid, open (T32F)	P	1500	1200
2x3/2-way single solenoid, open/closed (T32W)	R	1500	1200
2x2/2-way single solenoid, closed (T22C)	VC	1500	1200
2x2/2-way single solenoid, closed (T22CV)	VV	1500	1200

Datasheet – Solenoid valve width 26 mm

Technical data - Valve, width 26 mm							
Valve function (with valve code)	Terminal code	Flow direction			Reset method		Weight [g]
		Any	Only reversible	Not reversible	Pneumatic spring	Mechanical spring	
5/2-way double solenoid (B52)	J	■	–	–	–	–	276
5/2-way double solenoid with dominant signal (D52)	D	■	–	–	–	–	276
5/2-way single solenoid (M52A)	M	■	–	–	■	–	293
5/2-way single solenoid (M52M)	O	■	–	–	–	■	293
5/3-way closed ¹⁾ (P53C)	G	■	–	–	–	■	320
5/3-way exhausted ¹⁾ (P53E)	E	■	–	–	–	■	320
5/3-way pressurised ¹⁾ (P53U)	B	■	–	–	–	■	320
5/3-way exhausted, switching position 14 detenting (P53ED)	SA	–	–	■	–	■	291
5/3-way exhausted, switching position 12 detenting (P53EP)	SE	–	–	■	–	■	291
5/3-way, port 2 pressurised, 4 exhausted, switching position 14 detenting (P53AD)	SB	■	–	–	–	■	301
5/3-way, port 4 pressurised, 2 exhausted, switching position 14 detenting (P53BD)	SD	–	–	■	–	■	301
2x3/2-way single solenoid, closed (T32C)	K	–	–	■	■	–	335
2x3/2-way single solenoid, open (T32U)	N	–	–	■	■	–	335
2x3/2-way single solenoid, open/closed (T32H)	H	–	–	■	■	–	335
2x3/2-way single solenoid, closed (T32N)	Q	–	■	–	■	–	335
2x3/2-way single solenoid, open (T32F)	P	–	■	–	■	–	335
2x3/2-way single solenoid, open/closed (T32W)	R	–	■	–	■	–	335
2x2/2-way single solenoid, closed (T22C)	VC	–	–	■	■	–	335
2x2/2-way single solenoid, closed (T22CV)	VV	■	–	–	■	–	335

- 1) If neither solenoid coil is energised, the valve is moved to its mid-position by spring force.
If both solenoid coils are energised at the same time, the valve remains in the previously assumed switching position.

Datasheet – Solenoid valve width 26 mm

Standard nominal flow rate of valve/valve terminal [l/min], width 26 mm					
Valve function (with valve code)	Terminal code	Flow rate			
		Valve	Valve on valve terminal VTSA	Valve on valve terminal VTSA-F	Valve on individual sub-base
5/2-way double solenoid (B52)	J	1400	1100	1350	1200
5/2-way double solenoid with dominant signal (D52)	D	1400	1100	1350	1200
5/2-way single solenoid (M52A)	M	1400	1100	1350	1200
5/2-way single solenoid (M52M)	O	1400	1100	1350	1200
5/3-way closed (P53C)	G	1400 ¹⁾ 700 ²⁾	1000 ¹⁾ 700 ²⁾	1350 ¹⁾ 700 ²⁾	1200 ¹⁾ 700 ²⁾
5/3-way exhausted (P53E)	E	1400 ¹⁾ 700 ²⁾	1000 ¹⁾ 700 ²⁾	1350 ¹⁾ 700 ²⁾	1200 ¹⁾ 700 ²⁾
5/3-way pressurised (P53U)	B	1400 ¹⁾ 700 ²⁾	1000 ¹⁾ 700 ²⁾	1350 ¹⁾ 700 ²⁾	1200 ¹⁾ 700 ²⁾
5/3-way exhausted, switching position 14 detenting (P53ED)	SA	1400 ¹⁾ 700 ²⁾	1000 ¹⁾ 700 ²⁾	1350 ¹⁾ 700 ²⁾	1200 ¹⁾ 700 ²⁾
5/3-way exhausted, switching position 12 detenting (P53EP)	SE	1400 ¹⁾ 700 ²⁾	1000 ¹⁾ 700 ²⁾	1350 ¹⁾ 700 ²⁾	1200 ¹⁾ 700 ²⁾
5/3-way, port 2 pressurised, 4 exhausted, switching position 14 detenting (P53AD)	SB	700 ¹⁾ 700 ²⁾	700 ¹⁾ 700 ²⁾	700 ¹⁾ 700 ²⁾	700 ¹⁾ 700 ²⁾
5/3-way, port 4 pressurised, 2 exhausted, switching position 14 detenting (P53BD)	SD	–	850 ¹⁾ 820 ²⁾	950 ¹⁾ 860 ²⁾	900 ¹⁾ 840 ²⁾
2x3/2-way single solenoid, closed (T32C)	K	1250	900	1150	1100
2x3/2-way single solenoid, open (T32U)	N	1250	900	1150	1100
2x3/2-way single solenoid, open/closed (T32H)	H	1250	900	1150	1100
2x3/2-way single solenoid, closed (T32N)	Q	1250	900	1150	1100
2x3/2-way single solenoid, open (T32F)	P	1250	900	1150	1100
2x3/2-way single solenoid, open/closed (T32W)	R	1250	900	1150	1100
2x2/2-way single solenoid, closed (T22C)	VC	1350	1000	1300	1100
2x2/2-way single solenoid, closed (T22CV)	VV	1350	1000	1300	1100

1) Switching position

2) Mid-position

**Note**

The solenoid valves VSVA-B-P53BD...-A1-1T1L (terminal code SD) can be operated without restrictions at an operating pressure of less than 6 bar. At an operating pressure of more than 6 bar, the actual flow rate must not exceed 1900 l/min (e.g. 10-->2 bar), otherwise these solenoid valves may switch unintentionally (to the mid-position or switching position 14).

At high pressures, this can be achieved, for example, using a flow control valve/orifice. (e.g. a reducing nipple on port 2 or 4 to reduce it from G1/4 to G1/8).

Datasheet – Solenoid valve width 26 mm

Valve switching times in [ms], width 26 mm				
Valve function (with valve code)	Terminal code	On	Off	Changeover
5/2-way double solenoid (B52)	J	–	–	18
5/2-way double solenoid with dominant signal (D52)	D	–	–	21
5/2-way single solenoid (M52A)	M	25	45	–
5/2-way single solenoid (M52M)	O	20	65	–
5/3-way closed (P53C)	G	22	65	–
5/3-way exhausted (P53E)	E	22	65	–
5/3-way pressurised (P53U)	B	22	65	–
5/3-way exhausted, switching position 14 detenting (P53ED)	SA	22 for control side 12 9 for control side 14	49 for control side 12	33
5/3-way exhausted, switching position 12 detenting (P53EP)	SE	10 for control side 12 22 for control side 14	50 for control side 14	40
5/3-way, port 2 pressurised, 4 exhausted, switching position 14 detenting (P53AD)	SB	19 for control side 12 9 for control side 14	36 for control side 12	32
5/3-way, port 4 pressurised, 2 exhausted, switching position 14 detenting (P53BD)	SD	16 for control side 12 9 for control side 14	26 for control side 12 36 for control side 14	–
2x3/2-way single solenoid, closed (T32C)	K	20	38	–
2x3/2-way single solenoid, open (T32U)	N	20	38	–
2x3/2-way single solenoid, open/closed (T32H)	H	20	38	–
2x3/2-way single solenoid, closed (T32N)	Q	32	30	–
2x3/2-way single solenoid, open (T32F)	P	32	30	–
2x3/2-way single solenoid, open/closed (T32W)	R	32	30	–
2x2/2-way single solenoid, closed (T22C)	VC	20	38	–
2x2/2-way single solenoid, closed (T22CV)	VV	20	38	–

Characteristic coil values, width 26 mm		
Valve function (with valve code)	Terminal code	Characteristic coil values at 24 V DC in [W]
5/2-way double solenoid (B52)	J	1.6
5/2-way double solenoid with dominant signal (D52)	D	1.3
5/2-way single solenoid (M52A)	M	1.6
5/2-way single solenoid (M52M)	O	1.6
5/3-way closed (P53C)	G	1.6
5/3-way exhausted (P53E)	E	1.6
5/3-way pressurised (P53U)	B	1.6
5/3-way exhausted, switching position 14 detenting (P53ED)	SA	1.6
5/3-way exhausted, switching position 12 detenting (P53EP)	SE	1.6
5/3-way, port 2 pressurised, 4 exhausted, switching position 14 detenting (P53AD)	SB	1.6
5/3-way, port 4 pressurised, 2 exhausted, switching position 14 detenting (P53BD)	SD	1.6
2x3/2-way single solenoid, closed (T32C)	K	1.3
2x3/2-way single solenoid, open (T32U)	N	1.3
2x3/2-way single solenoid, open/closed (T32H)	H	1.3
2x3/2-way single solenoid, closed (T32N)	Q	1.3
2x3/2-way single solenoid, open (T32F)	P	1.3
2x3/2-way single solenoid, open/closed (T32W)	R	1.3
2x2/2-way single solenoid, closed (T22C)	VC	1.3
2x2/2-way single solenoid, closed (T22CV)	VV	1.3

Materials	
Housing	Die-cast aluminium, PA
Seals	FPM, NBR, HNBR
Screws	Galvanised steel
Note on materials	RoHS-compliant

Ordering data – Solenoid valve

Ordering data – Solenoid valve VSVA, MO non-detenting/detenting (D)						
	Terminal code	Valve function	Valve code	Width	Part no.	Type
Solenoid valves						
	VC	2x 2/2-way valve, single solenoid, normally closed, pneumatic spring return	T22C	26 mm	561149	VSVA-B-T22C-AZD-A1-1T1L
	VV	2x 2/2-way valve, single solenoid, normally closed, pneumatic spring return, vacuum operation possible at 3 and 5	T22CV	26 mm	561153	VSVA-B-T22CV-AZD-A1-1T1L
	N	2x 3/2-way valve, single solenoid, normally open	T32U	26 mm	539152	VSVA-B-T32U-AZD-A1-1T1L
	K	2x 3/2-way valve, single solenoid, normally closed	T32C	26 mm	539150	VSVA-B-T32C-AZD-A1-1T1L
	H	2x 3/2-way valve, single solenoid, 1x normally open, 1x normally closed	T32H	26 mm	539154	VSVA-B-T32H-AZD-A1-1T1L
	P	2x 3/2-way valve, single solenoid, reverse operation, normally open	T32F	26 mm	539153	VSVA-B-T32F-AZD-A1-1T1L
	Q	2x 3/2-way valve, single solenoid, reverse operation, normally closed	T32N	26 mm	539151	VSVA-B-T32N-AZD-A1-1T1L
	R	2x 3/2-way valve, single solenoid, reverse operation, 1x normally open, 1x normally closed	T32W	26 mm	539155	VSVA-B-T32W-AZD-A1-1T1L
	M	5/2-way valve, single solenoid, pneumatic spring return	M52-A	26 mm	539158	VSVA-B-M52-AZD-A1-1T1L
	O	5/2-way valve, single solenoid, mechanical spring return	M52-M	26 mm	539159	VSVA-B-M52-MZD-A1-1T1L
	J	5/2-way valve, double solenoid	B52	26 mm	539156	VSVA-B-B52-ZD-A1-1T1L
	D	5/2-way valve, double solenoid, with dominant signal	D52	26 mm	539157	VSVA-B-D52-ZD-A1-1T1L
	B	5/3-way solenoid valve, mid-position pressurised	P53U	26 mm	539160	VSVA-B-P53U-ZD-A1-1T1L
	G	5/3-way solenoid valve, mid-position closed	P53C	26 mm	539162	VSVA-B-P53C-ZD-A1-1T1L
	E	5/3-way solenoid valve, mid-position exhausted	P53E	26 mm	539161	VSVA-B-P53E-ZD-A1-1T1L
	SA	5/3-way solenoid valve, mid-position exhausted, switching position 14 detenting, mechanical spring return	P53ED	26 mm	560727	VSVA-B-P53ED-ZD-A1-1T1L
	SE	5/3-way solenoid valve, mid-position exhausted, switching position 12 detenting, mechanical spring return	P53EP	26 mm	8026638	VSVA-B-P53EP-ZD-A1-1T1L
	SB	5/3-way solenoid valve, mid-position 1x exhausted from 4 to 5, 1x pressurised from 1 to 2, switching position 14 detenting, same function in both switching positions: pressurised from 1 to 4 and exhausted from 2 to 3, mechanical spring return	P53AD	26 mm	560728	VSVA-B-P53AD-ZD-A1-1T1L
SD	5/3-way solenoid valve, mid-position 1x exhausted from 2 to 3, 1x pressurised from 1 to 4, switching position 14 detenting, same function in both switching positions: pressurised from 1 to 2 and exhausted from 4 to 5, mechanical spring return	P53BD	26 mm	8031816	VSVA-B-P53BD-ZD-A1-1T1L	

Ordering data – Solenoid valve

Ordering data – Solenoid valve VSVA with cover cap for MO non-detenting/heavy duty, detenting via accessory (TR)

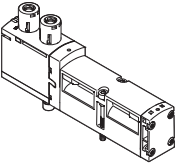
	Terminal code	Valve function	Valve code	Width	Part no.	Type
Solenoid valves						
	VC	2x 2/2-way valve, single solenoid, normally closed, pneumatic spring return	T22C	26 mm	8033032	VSVA-B-T22C-AZTR-A1-1T1L
	VV	2x 2/2-way valve, single solenoid, normally closed, pneumatic spring return, vacuum operation possible at 3 and 5	T22CV	26 mm	8033033	VSVA-B-T22CV-AZTR-A1-1T1L
	N	2x 3/2-way valve, single solenoid, normally open	T32U	26 mm	8033015	VSVA-B-T32U-AZTR-A1-1T1L
	K	2x 3/2-way valve, single solenoid, normally closed	T32C	26 mm	8033013	VSVA-B-T32C-AZTR-A1-1T1L
	H	2x 3/2-way valve, single solenoid, 1x normally open, 1x normally closed	T32H	26 mm	8033017	VSVA-B-T32H-AZTR-A1-1T1L
	P	2x 3/2-way valve, single solenoid, reverse operation, normally open	T32F	26 mm	8033016	VSVA-B-T32F-AZTR-A1-1T1L
	Q	2x 3/2-way valve, single solenoid, reverse operation, normally closed	T32N	26 mm	8033014	VSVA-B-T32N-AZTR-A1-1T1L
	R	2x 3/2-way valve, single solenoid, reverse operation, 1x normally open, 1x normally closed	T32W	26 mm	8033018	VSVA-B-T32W-AZTR-A1-1T1L
	M	5/2-way valve, single solenoid, pneumatic spring return	M52-A	26 mm	8033021	VSVA-B-M52-AZTR-A1-1T1L
	O	5/2-way valve, single solenoid, mechanical spring return	M52-M	26 mm	8033022	VSVA-B-M52-MZTR-A1-1T1L
	J	5/2-way valve, double solenoid	B52	26 mm	8033019	VSVA-B-B52-ZTR-A1-1T1L
	D	5/2-way valve, double solenoid, with dominant signal	D52	26 mm	8033020	VSVA-B-D52-ZTR-A1-1T1L
	B	5/3-way solenoid valve, mid-position pressurised	P53U	26 mm	8033023	VSVA-B-P53U-ZTR-A1-1T1L
	G	5/3-way solenoid valve, mid-position closed	P53C	26 mm	8033025	VSVA-B-P53C-ZTR-A1-1T1L
	E	5/3-way solenoid valve, mid-position exhausted	P53E	26 mm	8033024	VSVA-B-P53E-ZTR-A1-1T1L
	SA	5/3-way solenoid valve, mid-position exhausted, switching position 14 detenting, mechanical spring return	P53ED	26 mm	8033028	VSVA-B-P53ED-ZTR-A1-1T1L
	SE	5/3-way solenoid valve, mid-position exhausted, switching position 12 detenting, mechanical spring return	P53EP	26 mm	8033035	VSVA-B-P53EP-ZTR-A1-1T1L
SB	5/3-way solenoid valve, mid-position 1x exhausted from 4 to 5, 1x pressurised from 1 to 2, switching position 14 detenting, same function in both switching positions: pressurised from 1 to 4 and exhausted from 2 to 3, mechanical spring return	P53AD	26 mm	8033029	VSVA-B-P53AD-ZTR-A1-1T1L	
SD	5/3-way solenoid valve, mid-position 1x exhausted from 2 to 3, 1x pressurised from 1 to 4, switching position 14 detenting, same function in both switching positions: pressurised from 1 to 2 and exhausted from 4 to 5, mechanical spring return	P53BD	26 mm	8039187	VSVA-B-P53BD-ZTR-A1-1T1L	

Ordering data – Solenoid valve

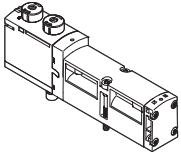
Ordering data – Solenoid valve VSVA with cover cap for MO, non-detenting (H)						
	Terminal code	Valve function	Valve code	Width	Part no.	Type
Solenoid valves						
	VC	2x 2/2-way valve, single solenoid, normally closed, pneumatic spring return	T22C	26 mm	8033055	VSVA-B-T22C-AZH-A1-1T1L
	VV	2x 2/2-way valve, single solenoid, normally closed, Pneumatic spring return, vacuum operation possible at 3 and 5	T22CV	26 mm	8033056	VSVA-B-T22CV-AZH-A1-1T1L
	N	2x 3/2-way valve, single solenoid, normally open	T32U	26 mm	8033038	VSVA-B-T32U-AZH-A1-1T1L
	K	2x 3/2-way valve, single solenoid, normally closed	T32C	26 mm	8033036	VSVA-B-T32C-AZH-A1-1T1L
	H	2x 3/2-way valve, single solenoid, 1x normally open, 1x normally closed	T32H	26 mm	8033040	VSVA-B-T32H-AZH-A1-1T1L
	P	2x 3/2-way valve, single solenoid, reverse operation, normally open	T32F	26 mm	8033039	VSVA-B-T32F-AZH-A1-1T1L
	Q	2x 3/2-way valve, single solenoid, reverse operation, normally closed	T32N	26 mm	8033037	VSVA-B-T32N-AZH-A1-1T1L
	R	2x 3/2-way valve, single solenoid, reverse operation, 1x normally open, 1x normally closed	T32W	26 mm	8033041	VSVA-B-T32W-AZH-A1-1T1L
	M	5/2-way valve, single solenoid, pneumatic spring return	M52-A	26 mm	8033044	VSVA-B-M52-AZH-A1-1T1L
	O	5/2-way valve, single solenoid, mechanical spring return	M52-M	26 mm	8033045	VSVA-B-M52-MZH-A1-1T1L
	J	5/2-way valve, double solenoid	B52	26 mm	8033042	VSVA-B-B52-ZH-A1-1T1L
	D	5/2-way valve, double solenoid, with dominant signal	D52	26 mm	8033043	VSVA-B-D52-ZH-A1-1T1L
	B	5/3-way solenoid valve, mid-position pressurised	P53U	26 mm	8033046	VSVA-B-P53U-ZH-A1-1T1L
	G	5/3-way solenoid valve, mid-position closed	P53C	26 mm	8033048	VSVA-B-P53C-ZH-A1-1T1L
	E	5/3-way solenoid valve, mid-position exhausted	P53E	26 mm	8033047	VSVA-B-P53E-ZH-A1-1T1L
	SA	5/3-way solenoid valve, mid-position exhausted, switching position 14 detenting, mechanical spring return	P53ED	26 mm	8033051	VSVA-B-P53ED-ZH-A1-1T1
	SE	5/3-way solenoid valve, mid-position exhausted, switching position 12 detenting, mechanical spring return	P53EP	26 mm	8033058	VSVA-B-P53EP-ZH-A1-1T1L
SB	5/3-way solenoid valve, mid-position 1x exhausted from 4 to 5, 1x pressurised from 1 to 2, switching position 14 detenting, same function in both switching positions: pressurised from 1 to 4 and exhausted from 2 to 3, mechanical spring return	P53AD	26 mm	8033052	VSVA-B-P53AD-ZH-A1-1T1L	
SD	5/3-way solenoid valve, mid-position 1x exhausted from 2 to 3, 1x pressurised from 1 to 4, switching position 14 detenting, same function in both switching positions: pressurised from 1 to 2 and exhausted from 4 to 5, mechanical spring return	P53BD	26 mm	8039188	VSVA-B-P53BD-ZH-A1-1T1L	

Ordering data – Solenoid valve

Ordering data – Solenoid valve VSVA with cover cap for MO, concealed

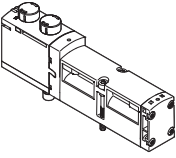
	Terminal code	Valve function	Valve code	Width	Part no.	Type
Solenoid valves						
	VC	2x 2/2-way valve, single solenoid, normally closed, pneumatic spring return	T22C	26 mm	8033078	VSVA-B-T22C-AZ-A1-1T1L
	VV	2x 2/2-way valve, single solenoid, normally closed, pneumatic spring return, vacuum operation possible at 3 and 5	T22CV	26 mm	8033079	VSVA-B-T22CV-AZ-A1-1T1L
	N	2x 3/2-way valve, single solenoid, normally open	T32U	26 mm	8033061	VSVA-B-T32U-AZ-A1-1T1L
	K	2x 3/2-way valve, single solenoid, normally closed	T32C	26 mm	8033059	VSVA-B-T32C-AZ-A1-1T1L
	H	2x 3/2-way valve, single solenoid, 1x normally open, 1x normally closed	T32H	26 mm	8033063	VSVA-B-T32H-AZ-A1-1T1L
	P	2x 3/2-way valve, single solenoid, reverse operation, normally open	T32F	26 mm	8033062	VSVA-B-T32F-AZ-A1-1T1L
	Q	2x 3/2-way valve, single solenoid, reverse operation, normally closed	T32N	26 mm	8033060	VSVA-B-T32N-AZ-A1-1T1L
	R	2x 3/2-way valve, single solenoid, reverse operation, 1x normally open, 1x normally closed	T32W	26 mm	8033064	VSVA-B-T32W-AZ-A1-1T1L
	M	5/2-way valve, single solenoid, pneumatic spring return	M52-A	26 mm	8033067	VSVA-B-M52-AZ-A1-1T1L
	O	5/2-way valve, single solenoid, mechanical spring return	M52-M	26 mm	8033068	VSVA-B-M52-MZ-A1-1T1L
	J	5/2-way valve, double solenoid	B52	26 mm	8033065	VSVA-B-B52-Z-A1-1T1L
	D	5/2-way valve, double solenoid, with dominant signal	D52	26 mm	8033066	VSVA-B-D52-Z-A1-1T1L
	B	5/3-way solenoid valve, mid-position pressurised	P53U	26 mm	8033069	VSVA-B-P53U-Z-A1-1T1L
	G	5/3-way solenoid valve, mid-position closed	P53C	26 mm	8033071	VSVA-B-P53C-Z-A1-1T1L
	E	5/3-way solenoid valve, mid-position exhausted	P53E	26 mm	8033070	VSVA-B-P53E-Z-A1-1T1L
	SA	5/3-way solenoid valve, mid-position exhausted, switching position 14 detenting, mechanical spring return	P53ED	26 mm	8033074	VSVA-B-P53ED-Z-A1-1T1L
	SE	5/3-way solenoid valve, mid-position exhausted, switching position 12 detenting, mechanical spring return	P53EP	26 mm	8033081	VSVA-B-P53EP-Z-A1-1T1L
SB	5/3-way solenoid valve, mid-position 1x exhausted from 4 to 5, 1x pressurised from 1 to 2, switching position 14 detenting, same function in both switching positions: pressurised from 1 to 4 and exhausted from 2 to 3, mechanical spring return	P53AD	26 mm	8033075	VSVA-B-P53AD-Z-A1-1T1L	
SD	5/3-way solenoid valve, mid-position 1x exhausted from 2 to 3, 1x pressurised from 1 to 4, switching position 14 detenting, same function in both switching positions: pressurised from 1 to 2 and exhausted from 4 to 5, mechanical spring return	P53BD	26 mm	8039189	VSVA-B-P53BD-Z-A1-1T1L	

Datasheet – Solenoid valve width 42 mm

-  Valve width
to ISO 5599-2
42 mm (ISO 1)

-  Flow rate
Width 42 mm:
VTSA up to 1300 l/min
VTSA-F up to 1860 l/min

-  Voltage
24 V DC

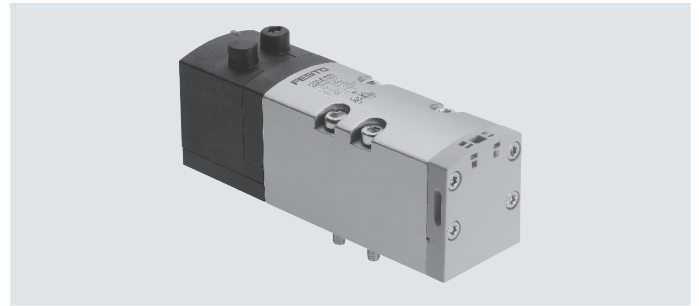
**Safety characteristics – Valve, width 42 mm**

Conforms to standard	EN 13849-1/2
Shock resistance	Shock test with severity level 2, to EN 60068-2-27
Vibration resistant	Transport application test with severity level 2, to EN 60068-2-6

Safety characteristics – Valve, width 42 mm

Valve function (with valve code)	Terminal code	Test pulses	
		Max. positive test pulse with 0 signal [μ s]	Max. negative test pulse with 1 signal [μ s]
5/2-way double solenoid (B52)	J	1400	900
5/2-way double solenoid with dominant signal (D52)	D	1600	1100
5/2-way single solenoid (M52A)	M	1400	900
5/2-way single solenoid (M52M)	O	1400	900
5/3-way closed (P53C)	G	1400	900
5/3-way exhausted (P53E)	E	1400	900
5/3-way pressurised (P53U)	B	1400	900
5/3-way, 1 to 2 pressurised, 4 to 5 closed (P53F)	VG	–	–
2x3/2-way single solenoid, closed (T32C)	K	1600	1100
2x3/2-way single solenoid, open (T32U)	N	1600	1100
2x3/2-way single solenoid, open/closed (T32H)	H	1600	1100
2x3/2-way single solenoid, closed (T32N)	Q	1600	1100
2x3/2-way single solenoid, open (T32F)	P	1600	1100
2x3/2-way single solenoid, open/closed (T32W)	R	1600	1100
2x2/2-way single solenoid, closed (T22C)	VC	1600	1100
2x2/2-way single solenoid, closed (T22CV)	VV	1600	1100

Datasheet – Solenoid valve width 42 mm

Technical data - Valve, width 42 mm							
Valve function (with valve code)	Terminal code	Flow direction			Reset method		Weight [g]
		Any	Only reversible	Not reversible	Pneumatic spring	Mechanical spring	
5/2-way double solenoid (B52)	J	■	–	–	–	–	439
5/2-way double solenoid with dominant signal (D52)	D	■	–	–	–	–	439
5/2-way single solenoid (M52A)	M	■	–	–	■	–	426
5/2-way single solenoid (M52M)	O	■	–	–	–	■	426
5/3-way closed ¹⁾ (P53C)	G	■	–	–	–	■	456
5/3 exhausted ¹⁾ (P53E)	E	■	–	–	–	■	456
5/3 pressurised ¹⁾ (P53U)	B	■	–	–	–	■	456
5/3-way, 1 to 2 pressurised, 4 to 5 closed (P53F)	VG	■	–	–	–	–	456
2x3/2-way single solenoid, closed (T32C)	K	–	–	■	■	–	442
2x3/2-way single solenoid, open (T32U)	N	–	–	■	■	–	442
2x3/2-way single solenoid, open/closed (T32H)	H	–	–	■	■	–	442
2x3/2-way single solenoid, closed (T32N)	Q	–	■	–	■	–	442
2x3/2-way single solenoid, open (T32F)	P	–	■	–	■	–	442
2x3/2-way single solenoid, open/closed (T32W)	R	–	■	–	■	–	442
2x2/2-way single solenoid, closed (T22C)	VC	–	–	■	■	–	442
2x2/2-way single solenoid, closed (T22CV)	VV	■	–	–	■	–	442

- 1) If neither solenoid coil is energised, the valve is moved to its mid-position by spring force.
 If both solenoid coils are energised at the same time, the valve remains in the previously assumed switching position.

Standard nominal flow rate of valve/valve terminal [l/min], width 42 mm					
Valve function (with valve code)	Terminal code	Flow rate			
		Valve	Valve on valve terminal VTSA	Valve on valve terminal VTSA-F	Valve on individual sub-base
5/2-way double solenoid (B52)	J	2000	1300	1860	1500
5/2-way double solenoid with dominant signal (D52)	D	2000	1300	1860	1500
5/2-way single solenoid (M52A)	M	2000	1300	1860	1500
5/2-way single solenoid (M52M)	O	2000	1300	1860	1500
5/3-way closed (P53C)	G	1900 ¹⁾ 950 ²⁾	1200 ¹⁾ 800 ²⁾	1690 ¹⁾ 830 ²⁾	1400 ¹⁾ 800 ²⁾
5/3-way exhausted (P53E)	E	1900 ¹⁾ 950 ²⁾	1200 ¹⁾ 800 ²⁾	1690 ¹⁾ 830 ²⁾	1400 ¹⁾ 800 ²⁾
5/3-way pressurised (P53U)	B	1900 ¹⁾ 950 ²⁾	1200 ¹⁾ 800 ²⁾	1690 ¹⁾ 830 ²⁾	1400 ¹⁾ 800 ²⁾
5/3-way, 1 to 2 pressurised, 4 to 5 closed (P53F)	VG	1700 ¹⁾ 700 ²⁾	1400 ¹⁾ 800 ²⁾	1700 ¹⁾ 700 ²⁾	1400 ¹⁾ 700 ²⁾
2x3/2-way single solenoid, closed (T32C)	K	1600	1200	1300	1200
2x3/2-way single solenoid, open (T32U)	N	1600	1200	1300	1200
2x3/2-way single solenoid, open/closed (T32H)	H	1600	1200	1300	1200
2x3/2-way single solenoid, closed (T32N)	Q	1600	1200	1300	1200
2x3/2-way single solenoid, open (T32F)	P	1600	1200	1300	1200
2x3/2-way single solenoid, open/closed (T32W)	R	1600	1200	1300	1200
2x2/2-way single solenoid, closed (T22C)	VC	1600	1400	1500	1400
2x2/2-way single solenoid, closed (T22CV)	VV	1600	1400	1500	1400

- 1) Switching position
 2) Mid-position

Datasheet – Solenoid valve width 42 mm

Valve switching times in [ms], width 42 mm				
Valve function (with valve code)	Terminal code	On	Off	Changeover
5/2-way double solenoid (B52)	J	–	–	16
5/2-way double solenoid with dominant signal (D52)	D	–	–	19
5/2-way single solenoid (M52A)	M	27	45	–
5/2-way single solenoid (M52M)	O	22	60	–
5/3-way closed (P53C)	G	22	65	38
5/3-way exhausted (P53E)	E	22	65	38
5/3-way pressurised (P53U)	B	22	65	38
5/3-way, 1 to 2 pressurised, 4 to 5 closed (P53F)	VG	22	65	38
2x3/2-way single solenoid, closed (T32C)	K	20	38	–
2x3/2-way single solenoid, open (T32U)	N	20	38	–
2x3/2-way single solenoid, open/closed (T32H)	H	20	38	–
2x3/2-way single solenoid, closed (T32N)	Q	34	28	–
2x3/2-way single solenoid, open (T32F)	P	34	28	–
2x3/2-way single solenoid, open/closed (T32W)	R	34	28	–
2x2/2-way single solenoid, closed (T22C)	VC	20	38	–
2x2/2-way single solenoid, closed (T22CV)	VV	20	38	–

Characteristic coil values, width 42 mm		
Valve function (with valve code)	Terminal code	[W]
5/2-way double solenoid (B52)	J	1.6
5/2-way double solenoid with dominant signal (D52)	D	1.3
5/2-way single solenoid (M52A)	M	1.6
5/2-way single solenoid (M52M)	O	1.6
5/3-way closed (P53C)	G	1.6
5/3-way exhausted (P53E)	E	1.6
5/3-way pressurised (P53U)	B	1.6
5/3-way, 1 to 2 pressurised, 4 to 5 closed (P53F)	VG	1.6
2x3/2-way single solenoid, closed (T32C)	K	1.3
2x3/2-way single solenoid, open (T32U)	N	1.3
2x3/2-way single solenoid, open/closed (T32H)	H	1.3
2x3/2-way single solenoid, closed (T32N)	Q	1.3
2x3/2-way single solenoid, open (T32F)	P	1.3
2x3/2-way single solenoid, open/closed (T32W)	R	1.3
2x2/2-way single solenoid, closed (T22C)	VC	1.3
2x2/2-way single solenoid, closed (T22CV)	VV	1.3

Max. current consumption per solenoid coil			
Type	T22, T32		B52, D52, M52, P53
At nominal voltage 24 V DC (valves with holding current reduction)			
Nominal pick-up current	[mA]	60	72
Nominal current following current reduction	[mA]	–	–
Time until current reduction	[ms]	30	30

Materials	
Housing	Die-cast aluminium, PA
Seals	FPM, NBR, HNBR
Screws	Galvanised steel
Note on materials	RoHS-compliant

Ordering data – Solenoid valve

Ordering data – Solenoid valve VSVA, MO non-detenting/detenting (D)

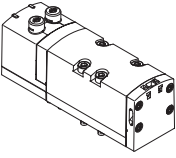
Terminal code	Valve function with MO detenting/non-detenting (D)	Valve code	Width	Part no.	Type	
Solenoid valves						
	VC	2x 2/2-way valve, single solenoid, normally closed, pneumatic spring return	T22C	42 mm	561340	VSVA-B-T22C-AZD-D1-1T1L
	VV	2x 2/2-way valve, single solenoid, normally closed, pneumatic spring return, vacuum operation possible at 3 and 5	T22CV	42 mm	561344	VSVA-B-T22CV-AZD-D1-1T1L
	N	2x 3/2-way valve, single solenoid, normally open	T32U	42 mm	543692	VSVA-B-T32U-AZD-D1-1T1L
	K	2x 3/2-way valve, single solenoid, normally closed	T32C	42 mm	543690	VSVA-B-T32C-AZD-D1-1T1L
	H	2x 3/2-way valve, single solenoid, 1x normally open, 1x normally closed	T32H	42 mm	543694	VSVA-B-T32H-AZD-D1-1T1L
	P	2x 3/2-way valve, single solenoid, reverse operation, normally open	T32F	42 mm	543693	VSVA-B-T32F-AZD-D1-1T1L
	Q	2x 3/2-way valve, single solenoid, reverse operation, normally closed	T32N	42 mm	543691	VSVA-B-T32N-AZD-D1-1T1L
	R	2x 3/2-way valve, single solenoid, reverse operation, 1x normally open, 1x normally closed	T32W	42 mm	543695	VSVA-B-T32W-AZD-D1-1T1L
	M	5/2-way valve, single solenoid, pneumatic spring return	M52-A	42 mm	543698	VSVA-B-M52-AZD-D1-1T1L
	O	5/2-way valve, single solenoid, mechanical spring return	M52-M	42 mm	543699	VSVA-B-M52-MZD-D1-1T1L
	J	5/2-way valve, double solenoid	B52	42 mm	543696	VSVA-B-B52-ZD-D1-1T1L
	D	5/2-way valve, double solenoid, with dominant signal	D52	42 mm	543697	VSVA-B-D52-ZD-D1-1T1L
	B	5/3-way solenoid valve, mid-position pressurised	P53U	42 mm	543700	VSVA-B-P53U-ZD-D1-1T1L
	G	5/3-way solenoid valve, mid-position closed	P53C	42 mm	543702	VSVA-B-P53C-ZD-D1-1T1L
	E	5/3-way solenoid valve, mid-position exhausted	P53E	42 mm	543701	VSVA-B-P53E-ZD-D1-1T1L
	VG	5/3-way solenoid valve, mid-position pressurised 1 to 2, 4 to 5 closed	P53F	42 mm	8000464	VSVA-B-P53F-ZD-D1-1T1L

Ordering data – Solenoid valve

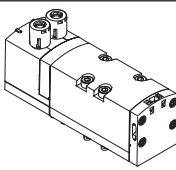
Ordering data – Solenoid valve VSVA with cover cap for MO non-detenting/heavy duty, detenting via accessory (TR)						
	Terminal code	Valve function	Valve code	Width	Part no.	Type
Solenoid valves						
	VC	2x 2/2-way valve, single solenoid, normally closed, pneumatic spring return	T22C	42 mm	8034781	VSVA-B-T22C-AZTR-D1-1T1L
	VV	2x 2/2-way valve, single solenoid, normally closed, pneumatic spring return, vacuum operation possible at 3 and 5	T22CV	42 mm	8034782	VSVA-B-T22CV-AZTR-D1-1T1L
	N	2x 3/2-way valve, single solenoid, normally open	T32U	42 mm	8034770	VSVA-B-T32U-AZTR-D1-1T1L
	K	2x 3/2-way valve, single solenoid, normally closed	T32C	42 mm	8034768	VSVA-B-T32C-AZTR-D1-1T1L
	H	2x 3/2-way valve, single solenoid, 1x normally open, 1x normally closed	T32H	42 mm	8034772	VSVA-B-T32H-AZTR-D1-1T1L
	P	2x 3/2-way valve, single solenoid, reverse operation, normally open	T32F	42 mm	8034771	VSVA-B-T32F-AZTR-D1-1T1L
	Q	2x 3/2-way valve, single solenoid, reverse operation, normally closed	T32N	42 mm	8034769	VSVA-B-T32N-AZTR-D1-1T1L
	R	2x 3/2-way valve, single solenoid, reverse operation, 1x normally open, 1x normally closed	T32W	42 mm	8034773	VSVA-B-T32W-AZTR-D1-1T1L
	M	5/2-way valve, single solenoid, pneumatic spring return	M52-A	42 mm	8034776	VSVA-B-M52-AZTR-D1-1T1L
	O	5/2-way valve, single solenoid, mechanical spring return	M52-M	42 mm	8034777	VSVA-B-M52-MZTR-D1-1T1L
	J	5/2-way valve, double solenoid	B52	42 mm	8034774	VSVA-B-B52-ZTR-D1-1T1L
	D	5/2-way valve, double solenoid, with dominant signal	D52	42 mm	8034775	VSVA-B-D52-ZTR-D1-1T1L
	B	5/3-way solenoid valve, mid-position pressurised	P53U	42 mm	8034778	VSVA-B-P53U-ZTR-D1-1T1L
	G	5/3-way solenoid valve, mid-position closed	P53C	42 mm	8034780	VSVA-B-P53C-ZTR-D1-1T1L
	E	5/3-way solenoid valve, mid-position exhausted	P53E	42 mm	8034779	VSVA-B-P53E-ZTR-D1-1T1L
VG	5/3-way solenoid valve, mid-position pressurised 1 to 2, 4 to 5 closed	P53F	42 mm	8034783	VSVA-B-P53F-ZTR-D1-1T1L	

Ordering data – Solenoid valve

Ordering data – Solenoid valve VSVA with cover cap for MO, non-detenting (H)

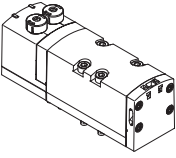
Terminal code	Valve function with MO non-detenting (H)	Valve code	Width	Part no.	Type	
Solenoid valves						
	VC	2x 2/2-way valve, single solenoid, normally closed, pneumatic spring return	T22C	42 mm	8034812	VSVA-B-T22C-AZH-D1-1T1L
	VV	2x 2/2-way valve, single solenoid, normally closed, pneumatic spring return, vacuum operation possible at 3 and 5	T22CV	42 mm	8034813	VSVA-B-T22CV-AZH-D1-1T1L
	N	2x 3/2-way valve, single solenoid, normally open	T32U	42 mm	8034801	VSVA-B-T32U-AZH-D1-1T1L
	K	2x 3/2-way valve, single solenoid, normally closed	T32C	42 mm	8034799	VSVA-B-T32C-AZH-D1-1T1L
	H	2x 3/2-way valve, single solenoid, 1x normally open, 1x normally closed	T32H	42 mm	8034803	VSVA-B-T32H-AZH-D1-1T1L
	P	2x 3/2-way valve, single solenoid, reverse operation, normally open	T32F	42 mm	8034802	VSVA-B-T32F-AZH-D1-1T1L
	Q	2x 3/2-way valve, single solenoid, reverse operation, normally closed	T32N	42 mm	8034800	VSVA-B-T32N-AZH-D1-1T1L
	R	2x 3/2-way valve, single solenoid, reverse operation, 1x normally open, 1x normally closed	T32W	42 mm	8034804	VSVA-B-T32W-AZH-D1-1T1L
	M	5/2-way valve, single solenoid, pneumatic spring return	M52-A	42 mm	8034807	VSVA-B-M52-AZH-D1-1T1L
	O	5/2-way valve, single solenoid, mechanical spring return	M52-M	42 mm	8034808	VSVA-B-M52-MZH-D1-1T1L
	J	5/2-way valve, double solenoid	B52	42 mm	8034805	VSVA-B-B52-ZH-D1-1T1L
	D	5/2-way valve, double solenoid, with dominant signal	D52	42 mm	8034806	VSVA-B-D52-ZH-D1-1T1L
	B	5/3-way solenoid valve, mid-position pressurised	P53U	42 mm	8034809	VSVA-B-P53U-ZH-D1-1T1L
	G	5/3-way solenoid valve, mid-position closed	P53C	42 mm	8034811	VSVA-B-P53C-ZH-D1-1T1L
	E	5/3-way solenoid valve, mid-position exhausted	P53E	42 mm	8034810	VSVA-B-P53E-ZH-D1-1T1L
VG	5/3-way solenoid valve, mid-position pressurised 1 to 2, 4 to 5 closed	P53F	42 mm	8034814	VSVA-B-P53F-ZH-D1-1T1L	

Ordering data – Solenoid valve

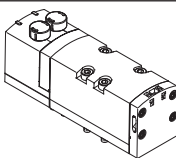
Ordering data – Solenoid valve VSVA with cover cap for MO, concealed						
	Terminal code	Valve function	Valve code	Width	Part no.	Type
Solenoid valves						
	VC	2x 2/2-way valve, single solenoid, normally closed, pneumatic spring return	T22C	42 mm	8034843	VSVA-B-T22C-AZ-D1-1T1L
	VV	2x 2/2-way valve, single solenoid, normally closed, pneumatic spring return, vacuum operation possible at 3 and 5	T22CV	42 mm	8034844	VSVA-B-T22CV-AZ-D1-1T1L
	N	2x 3/2-way valve, single solenoid, normally open	T32U	42 mm	8034832	VSVA-B-T32U-AZ-D1-1T1L
	K	2x 3/2-way valve, single solenoid, normally closed	T32C	42 mm	8034830	VSVA-B-T32C-AZ-D1-1T1L
	H	2x 3/2-way valve, single solenoid, 1x normally open, 1x normally closed	T32H	42 mm	8034834	VSVA-B-T32H-AZ-D1-1T1L
	P	2x 3/2-way valve, single solenoid, reverse operation, normally open	T32F	42 mm	8034833	VSVA-B-T32F-AZ-D1-1T1L
	Q	2x 3/2-way valve, single solenoid, reverse operation, normally closed	T32N	42 mm	8034831	VSVA-B-T32N-AZ-D1-1T1L
	R	2x 3/2-way valve, single solenoid, reverse operation, 1x normally open, 1x normally closed	T32W	42 mm	8034835	VSVA-B-T32W-AZ-D1-1T1L
	M	5/2-way valve, single solenoid, pneumatic spring return	M52-A	42 mm	8034838	VSVA-B-M52-AZ-D1-1T1L
	O	5/2-way valve, single solenoid, mechanical spring return	M52-M	42 mm	8034839	VSVA-B-M52-MZ-D1-1T1L
	J	5/2-way valve, double solenoid	B52	42 mm	8034836	VSVA-B-B52-Z-D1-1T1L
	D	5/2-way valve, double solenoid, with dominant signal	D52	42 mm	8034837	VSVA-B-D52-Z-D1-1T1L
	B	5/3-way solenoid valve, mid-position pressurised	P53U	42 mm	8034840	VSVA-B-P53U-Z-D1-1T1L
	G	5/3-way solenoid valve, mid-position closed	P53C	42 mm	8034842	VSVA-B-P53C-Z-D1-1T1L
	E	5/3-way solenoid valve, mid-position exhausted	P53E	42 mm	8034841	VSVA-B-P53E-Z-D1-1T1L
VG	5/3-way solenoid valve, mid-position pressurised 1 to 2, 4 to 5 closed	P53F	42 mm	8034845	VSVA-B-P53F-Z-D1-1T1L	

Datasheet – Solenoid valve width 52 mm

-  - Valve width
to ISO 5599-2
52 mm (ISO 2)

-  - Flow rate
Width 52 mm:
VTSA up to 2900 l/min
VTSA-F up to 2900 l/min

-  - Voltage
24 V DC

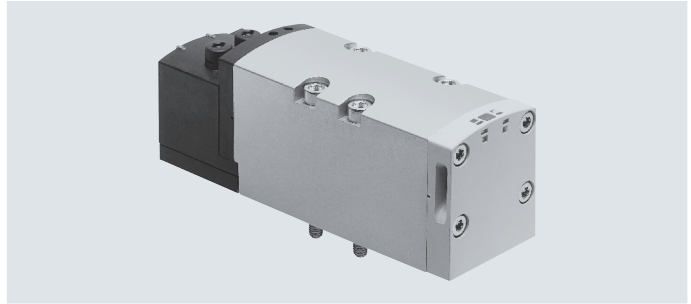

Safety characteristics for valve

Conforms to standard	EN 13849-1/2
CE marking (see declaration of conformity)	Direct voltage 24 V DC To EU EMC Directive 1)
KC marking	KC EMC
Shock resistance	Shock test with severity level 2, to EN 60068-2-27
Vibration resistant	Transport application test with severity level 2, to EN 60068-2-6

1) For information about the area of use, see the EC declaration of conformity at: [www.festo.com/catalogue/... d Support/Downloads](http://www.festo.com/catalogue/...d%20Support/Downloads).
If the devices are subject to usage restrictions in residential, commercial or light-industrial environments, further measures for the reduction of the emitted interference may be necessary.

Safety characteristics – Valve, width 52 mm

Valve function (with valve code)	Terminal code	Test pulses	
		Max. positive test pulse with logic 0 [µs]	Max. negative test pulse with logic 1 [µs]
5/2-way double solenoid (B52)	J	1000	3500
5/2-way double solenoid with dominant signal (D52)	D	1000	3500
5/2-way single solenoid (M52A)	M	1000	3500
5/2-way single solenoid (M52M)	O	1000	3500
5/3-way closed (P53C)	G	1000	3500
5/3-way exhausted (P53E)	E	1000	3500
5/3-way pressurised (P53U)	B	1000	3500
5/3-way, 1 to 2 pressurised, 4 to 5 closed (P53F)	VG	–	–
2x3/2-way single solenoid, closed (T32C)	K	1000	3500
2x3/2-way single solenoid, open (T32U)	N	1000	3500
2x3/2-way single solenoid, open/closed (T32H)	H	1000	3500
2x3/2-way single solenoid, closed (T32N)	Q	1000	3500
2x3/2-way single solenoid, open (T32F)	P	1000	3500
2x3/2-way single solenoid, open/closed (T32W)	R	1000	3500
2x2/2-way single solenoid, closed (T22C)	VC	1000	3500

Datasheet – Solenoid valve width 52 mm

Technical data - Valve, width 52 mm							
Valve function (with valve code)	Terminal code	Flow direction			Reset method		Weight [g]
		Any	Only reversible	Not reversible	Pneumatic spring	Mechanical spring	
5/2-way double solenoid (B52)	J	■	–	–	–	–	732
5/2-way double solenoid with dominant signal (D52)	D	■	–	–	–	–	732
5/2-way single solenoid (M52A)	M	■	–	–	■	–	702
5/2-way single solenoid (M52M)	O	■	–	–	–	■	702
5/3-way closed ¹⁾ (P53C)	G	■	–	–	–	■	780
5/3 exhausted ¹⁾ (P53E)	E	■	–	–	–	■	780
5/3 pressurised ¹⁾ (P53U)	B	■	–	–	–	■	780
5/3-way, 1 to 2 pressurised, 4 to 5 closed (P53F)	VG	■	–	–	–	–	780
2x3/2-way single solenoid, closed (T32C)	K	–	–	■	■	–	740
2x3/2-way single solenoid, open (T32U)	N	–	–	■	■	–	740
2x3/2-way single solenoid, open/closed (T32H)	H	–	–	■	■	–	740
2x3/2-way single solenoid, closed (T32N)	Q	–	■	–	■	–	740
2x3/2-way single solenoid, open (T32F)	P	–	■	–	■	–	740
2x3/2-way single solenoid, open/closed (T32W)	R	–	■	–	■	–	740
2x2/2-way single solenoid, closed (T22C)	VC	–	–	■	■	–	740

- 1) If neither solenoid coil is energised, the valve is moved to its mid-position by spring force.
If both solenoid coils are energised at the same time, the valve remains in the previously assumed switching position.

Standard nominal flow rate of valve/valve terminal [l/min], width 52 mm					
Valve function (with valve code)	Terminal code	Flow rate			
		Valve	Valve on valve terminal VTSA	Valve on valve terminal VTSA-F	Valve on individual sub-base
5/2-way double solenoid (B52)	J	4000	2900	2900	3400
5/2-way double solenoid with dominant signal (D52)	D	4000	2900	2900	3400
5/2-way single solenoid (M52A)	M	4000	2900	2900	3400
5/2-way single solenoid (M52M)	O	4000	2900	2900	3400
5/3-way closed (P53C)	G	3600 ¹⁾ 1700 ²⁾	2800 ¹⁾ 1700 ²⁾	2800 ¹⁾ 1700 ²⁾	3200 ¹⁾ 1700 ²⁾
5/3-way exhausted (P53E)	E	3600 ¹⁾ 1700 ²⁾	2800 ¹⁾ 1700 ²⁾	2800 ¹⁾ 1700 ²⁾	3200 ¹⁾ 1700 ²⁾
5/3-way pressurised (P53U)	B	3600 ¹⁾ 1700 ²⁾	2800 ¹⁾ 1700 ²⁾	2800 ¹⁾ 1700 ²⁾	3200 ¹⁾ 1700 ²⁾
5/3-way, 1 to 2 pressurised, 4 to 5 closed (P53F)	VG	3000 ¹⁾ 900 ²⁾	2300 ¹⁾ 900 ²⁾	2300 ¹⁾ 900 ²⁾	2600 ¹⁾ 900 ²⁾
2x3/2-way single solenoid, closed (T32C)	K	3000	2400	2400	2600
2x3/2-way single solenoid, open (T32U)	N	3000	2400	2400	2600
2x3/2-way single solenoid, open/closed (T32H)	H	3000	2400	2400	2600
2x3/2-way single solenoid, closed (T32N)	Q	3000	2400	2400	2600
2x3/2-way single solenoid, open (T32F)	P	3000	2400	2400	2600
2x3/2-way single solenoid, open/closed (T32W)	R	3000	2400	2400	2600
2x2/2-way single solenoid, closed (T22C)	VC	4000	2800	2800	3400

- 1) Switching position
2) Mid-position

Datasheet – Solenoid valve width 52 mm

Valve switching times in [ms], width 52 mm				
Valve function (with valve code)	Terminal code	On	Off	Changeover
5/2-way double solenoid (B52)	J	–	–	18
5/2-way double solenoid with dominant signal (D52)	D	–	–	18
5/2-way single solenoid (M52A)	M	40	45	–
5/2-way single solenoid (M52M)	O	20	60	–
5/3-way closed (P53C)	G	23	60	38
5/3-way exhausted (P53E)	E	23	60	38
5/3-way pressurised (P53U)	B	23	60	38
5/3-way, 1 to 2 pressurised, 4 to 5 closed (P53F)	VG	23	60	38
2x3/2-way single solenoid, closed (T32C)	K	20	35	–
2x3/2-way single solenoid, open (T32U)	N	20	35	–
2x3/2-way single solenoid, open/closed (T32H)	H	20	35	–
2x3/2-way single solenoid, closed (T32N)	Q	20	35	–
2x3/2-way single solenoid, open (T32F)	P	20	35	–
2x3/2-way single solenoid, open/closed (T32W)	R	20	35	–
2x2/2-way single solenoid, closed (T22C)	VC	14	35	–

Characteristic coil values, width 52 mm		
Valve function (with valve code)	Terminal code	[W]
5/2-way double solenoid (B52)	J	4.6
5/2-way double solenoid with dominant signal (D52)	D	4.6
5/2-way single solenoid (M52A)	M	4.6
5/2-way single solenoid (M52M)	O	4.6
5/3-way closed (P53C)	G	4.6
5/3-way exhausted (P53E)	E	4.6
5/3-way pressurised (P53U)	B	4.6
5/3-way, 1 to 2 pressurised, 4 to 5 closed (P53F)	VG	4.6
2x3/2-way single solenoid, closed (T32C)	K	4.6
2x3/2-way single solenoid, open (T32U)	N	4.6
2x3/2-way single solenoid, open/closed (T32H)	H	4.6
2x3/2-way single solenoid, closed (T32N)	Q	4.6
2x3/2-way single solenoid, open (T32F)	P	4.6
2x3/2-way single solenoid, open/closed (T32W)	R	4.6
2x2/2-way single solenoid, closed (T22C)	VC	4.6

Max. current consumption per solenoid coil, width 52 mm		
At nominal voltage 24 V DC (valves with holding current reduction)		
Nominal pick-up current	[mA]	165
Nominal current following current reduction	[mA]	35
Time until current reduction	[ms]	30

Materials	
Housing	Die-cast aluminium, PA
Seals	FPM, NBR, HNBR
Screws	Galvanised steel
Note on materials	RoHS-compliant

Ordering data – Solenoid valve

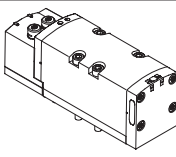
Ordering data – Solenoid valve VSVA, MO non-detenting/detenting (D)						
	Terminal code	Valve function	Valve code	Width	Part no.	Type
Solenoid valves						
	VC	2x 2/2-way valve, single solenoid, normally closed, pneumatic spring return	T22C	52 mm	560831	VSVA-B-T22C-AZD-D2-1T1L
	N	2x 3/2-way valve, single solenoid, normally open	T32U	52 mm	560827	VSVA-B-T32U-AZD-D2-1T1L
	K	2x 3/2-way valve, single solenoid, normally closed	T32C	52 mm	560825	VSVA-B-T32C-AZD-D2-1T1L
	H	2x 3/2-way valve, single solenoid, 1x normally open, 1x normally closed	T32H	52 mm	560829	VSVA-B-T32H-AZD-D2-1T1L
	P	2x 3/2-way valve, single solenoid, reverse operation, normally open	T32F	52 mm	560828	VSVA-B-T32F-AZD-D2-1T1L
	Q	2x 3/2-way valve, single solenoid, reverse operation, normally closed	T32N	52 mm	560826	VSVA-B-T32N-AZD-D2-1T1L
	R	2x 3/2-way valve, single solenoid, reverse operation, 1x normally open, 1x normally closed	T32W	52 mm	560830	VSVA-B-T32W-AZD-D2-1T1L
	M	5/2-way valve, single solenoid, pneumatic spring return	M52-A	52 mm	560820	VSVA-B-M52-AZD-D2-1T1L
	O	5/2-way valve, single solenoid, mechanical spring return	M52-M	52 mm	560821	VSVA-B-M52-MZD-D2-1T1L
	J	5/2-way valve, double solenoid	B52	52 mm	560818	VSVA-B-B52-ZD-D2-1T1L
	D	5/2-way valve, double solenoid, with dominant signal	D52	52 mm	560819	VSVA-B-D52-ZD-D2-1T1L
	B	5/3-way solenoid valve, mid-position pressurised	P53U	52 mm	560822	VSVA-B-P53U-ZD-D2-1T1L
	G	5/3-way solenoid valve, mid-position closed	P53C	52 mm	560824	VSVA-B-P53C-ZD-D2-1T1L
	E	5/3-way solenoid valve, mid-position exhausted	P53E	52 mm	560823	VSVA-B-P53E-ZD-D2-1T1L
	VG	5/3-way solenoid valve, mid-position pressurised 1 to 2, 4 to 5 closed	P53F	52 mm	8000465	VSVA-B-P53F-ZD-D2-1T1L

Ordering data – Solenoid valve

Ordering data – Solenoid valve VSVA with cover cap for MO non-detenting/heavy duty, detenting via accessory (TR)

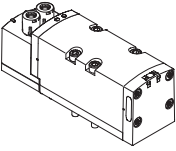
	Terminal code	Valve function	Valve code	Width	Part no.	Type
Solenoid valves						
	VC	2x 2/2-way valve, single solenoid, normally closed, pneumatic spring return	T22C	52 mm	8034967	VSVA-B-T22C-AZTR-D2-1T1L
	N	2x 3/2-way valve, single solenoid, normally open	T32U	52 mm	8034963	VSVA-B-T32U-AZTR-D2-1T1L
	K	2x 3/2-way valve, single solenoid, normally closed	T32C	52 mm	8034961	VSVA-B-T32C-AZTR-D2-1T1L
	H	2x 3/2-way valve, single solenoid, 1x normally open, 1x normally closed	T32H	52 mm	8034965	VSVA-B-T32H-AZTR-D2-1T1L
	P	2x 3/2-way valve, single solenoid, reverse operation, normally open	T32F	52 mm	8034964	VSVA-B-T32F-AZTR-D2-1T1L
	Q	2x 3/2-way valve, single solenoid, reverse operation, normally closed	T32N	52 mm	8034962	VSVA-B-T32N-AZTR-D2-1T1L
	R	2x 3/2-way valve, single solenoid, reverse operation, 1x normally open, 1x normally closed	T32W	52 mm	8034966	VSVA-B-T32W-AZTR-D2-1T1L
	M	5/2-way valve, single solenoid, pneumatic spring return	M52-A	52 mm	8034956	VSVA-B-M52-AZTR-D2-1T1L
	O	5/2-way valve, single solenoid, mechanical spring return	M52-M	52 mm	8034957	VSVA-B-M52-MZTR-D2-1T1L
	J	5/2-way valve, double solenoid	B52	52 mm	8034954	VSVA-B-B52-ZTR-D2-1T1L
	D	5/2-way valve, double solenoid, with dominant signal	D52	52 mm	8034955	VSVA-B-D52-ZTR-D2-1T1L
	B	5/3-way solenoid valve, mid-position pressurised	P53U	52 mm	8034958	VSVA-B-P53U-ZTR-D2-1T1L
	G	5/3-way solenoid valve, mid-position closed	P53C	52 mm	8034960	VSVA-B-P53C-ZTR-D2-1T1L
	E	5/3-way solenoid valve, mid-position exhausted	P53E	52 mm	8034959	VSVA-B-P53E-ZTR-D2-1T1L
	VG	5/3-way solenoid valve, mid-position pressurised 1 to 2, 4 to 5 closed	P53F	52 mm	8034968	VSVA-B-P53F-ZTR-D2-1T1L

Ordering data – Solenoid valve

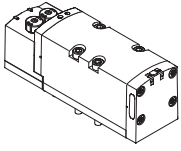
Ordering data – Solenoid valve VSVA with cover cap for MO, non-detenting (H)						
	Terminal code	Valve function	Valve code	Width	Part no.	Type
Solenoid valves						
	VC	2x 2/2-way valve, single solenoid, normally closed, pneumatic spring return	T22C	52 mm	8034982	VSVA-B-T22C-AZH-D2-1T1L
	N	2x 3/2-way valve, single solenoid, normally open	T32U	52 mm	8034978	VSVA-B-T32U-AZH-D2-1T1L
	K	2x 3/2-way valve, single solenoid, normally closed	T32C	52 mm	8034976	VSVA-B-T32C-AZH-D2-1T1L
	H	2x 3/2-way valve, single solenoid, 1x normally open, 1x normally closed	T32H	52 mm	8034980	VSVA-B-T32H-AZH-D2-1T1LL
	P	2x 3/2-way valve, single solenoid, reverse operation, normally open	T32F	52 mm	8034979	VSVA-B-T32F-AZH-D2-1T1L
	Q	2x 3/2-way valve, single solenoid, reverse operation, normally closed	T32N	52 mm	8034977	VSVA-B-T32N-AZH-D2-1T1L
	R	2x 3/2-way valve, single solenoid, reverse operation, 1x normally open, 1x normally closed	T32W	52 mm	8034981	VSVA-B-T32W-AZH-D2-1T1L
	M	5/2-way valve, single solenoid, pneumatic spring return	M52-A	52 mm	8034971	VSVA-B-M52-AZH-D2-1T1L
	O	5/2-way valve, single solenoid, mechanical spring return	M52-M	52 mm	8034972	VSVA-B-M52-MZH-D2-1T1L
	J	5/2-way valve, double solenoid	B52	52 mm	8034969	VSVA-B-B52-ZH-D2-1T1L
	D	5/2-way valve, double solenoid, with dominant signal	D52	52 mm	8034970	VSVA-B-D52-ZH-D2-1T1L
	B	5/3-way solenoid valve, mid-position pressurised	P53U	52 mm	8034973	VSVA-B-P53U-ZH-D2-1T1L
	G	5/3-way solenoid valve, mid-position closed	P53C	52 mm	8034975	VSVA-B-P53C-ZH-D2-1T1L
	E	5/3-way solenoid valve, mid-position exhausted	P53E	52 mm	8034974	VSVA-B-P53E-ZH-D2-1T1L
	VG	5/3-way solenoid valve, mid-position pressurised 1 to 2, 4 to 5 closed	P53F	52 mm	8034983	VSVA-B-P53F-ZH-D2-1T1L

Ordering data – Solenoid valve

Ordering data – Solenoid valve VSVA with cover cap for MO, concealed





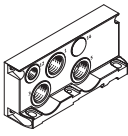
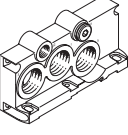
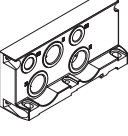
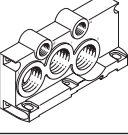
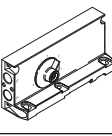
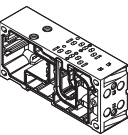
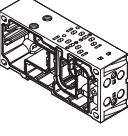

	Terminal code	Valve function	Valve code	Width	Part no.	Type
Solenoid valves						
	VC	2x 2/2-way valve, single solenoid, normally closed, pneumatic spring return	T22C	52 mm	8034997	VSVA-B-T22C-AZ-D2-1T1L
	N	2x 3/2-way valve, single solenoid, normally open	T32U	52 mm	8034993	VSVA-B-T32U-AZ-D2-1T1L
	K	2x 3/2-way valve, single solenoid, normally closed	T32C	52 mm	8034991	VSVA-B-T32C-AZ-D2-1T1L
	H	2x 3/2-way valve, single solenoid, 1x normally open, 1x normally closed	T32H	52 mm	8034995	VSVA-B-T32H-AZ-D2-1T1L
	P	2x 3/2-way valve, single solenoid, reverse operation, normally open	T32F	52 mm	8034994	VSVA-B-T32F-AZ-D2-1T1L
	Q	2x 3/2-way valve, single solenoid, reverse operation, Normally closed	T32N	52 mm	8034992	VSVA-B-T32N-AZ-D2-1T1L
	R	2x 3/2-way valve, single solenoid, reverse operation, 1x normally open, 1x normally closed	T32W	52 mm	8034996	VSVA-B-T32W-AZ-D2-1T1L
	M	5/2-way valve, single solenoid, pneumatic spring return	M52-A	52 mm	8034986	VSVA-B-M52-AZ-D2-1T1L
	O	5/2-way valve, single solenoid, mechanical spring return	M52-M	52 mm	8034987	VSVA-B-M52-MZ-D2-1T1L
	J	5/2-way valve, double solenoid	B52	52 mm	8034984	VSVA-B-B52-Z-D2-1T1L
	D	5/2-way valve, double solenoid, with dominant signal	D52	52 mm	8034985	VSVA-B-D52-Z-D2-1T1L
	B	5/3-way solenoid valve, mid-position pressurised	P53U	52 mm	8034988	VSVA-B-P53U-Z-D2-1T1L
	G	5/3-way solenoid valve, mid-position closed	P53C	52 mm	8034990	VSVA-B-P53C-Z-D2-1T1L
	E	5/3-way solenoid valve, mid-position exhausted	P53E	52 mm	8034989	VSVA-B-P53E-Z-D2-1T1L
	VG	5/3-way solenoid valve, mid-position pressurised 1 to 2, 4 to 5 closed	P53F	52 mm	8034998	VSVA-B-P53F-Z-D2-1T1L

Accessories – Pneumatic components

Ordering data					
	Code	Description	Part no.	Type	
Right end plate					
	V	With working air/exhaust air, internal pilot air supply, 1/2 NPT (no port 14)	539235	VABE-S6-1R-N12	
	V1	With working air/exhaust air, internal pilot air supply, 3/4 NPT (port 14 is sealed with a blanking plug)	560838	VABE-S6-2R-N34	
	X	With working air/exhaust air, external pilot air supply, 1/2 NPT	539237	VABE-S6-1RZ-N12	
	X1	With working air/exhaust air, external pilot air supply, 3/4 NPT	560840	VABE-S6-2RZ-N34	
End plate with pilot air selector					
	Y ¹⁾	Internal pilot air supply	539239	VABE-S6-1RZ-N-B1	
	U ¹⁾	Internal pilot air supply, ducted pilot exhaust air			
	Z ¹⁾	External pilot air supply			
	W ¹⁾	External pilot air supply, ducted pilot exhaust air			
Manifold sub-base, port pattern to ISO 15407-2 and ISO 5599-2					
	A	2 valve positions, 4 addresses, for double solenoid valves	18 mm	539223	VABV-S4-2S-N18-2T2
	B	2 valve positions, 4 addresses, for double solenoid valves	26 mm	539219	VABV-S4-1S-N14-2T2
	C	1 valve position, 2 addresses, for double solenoid valves	42 mm	542460	VABV-S2-1S-N38-T2
	D	1 valve position, 2 addresses, for double solenoid valves	52 mm	560843	VABV-S2-2S-N12-T2
	E	2 valve positions, 2 addresses, for single solenoid valves	18 mm	539225	VABV-S4-2S-N18-2T1
	F	2 valve positions, 2 addresses, for single solenoid valves	26 mm	539221	VABV-S4-1S-N14-2T1
	G	1 valve position, 1 address, for single solenoid valves	42 mm	542461	VABV-S2-1S-N38-T1
	H	1 valve position, 1 address, for single solenoid valves	52 mm	560844	VABV-S2-2S-N12-T1
Manifold sub-base VTSA-F, optimised for flow rate					
	A	2 valve positions, 4 addresses, for double solenoid valves	18 mm	546217	VABV-S4-2HS-N18-2T2
	B	2 valve positions, 4 addresses, for double solenoid valves	26 mm	546213	VABV-S4-1HS-N14-2T2
	C	1 valve position, 2 addresses, for double solenoid valves	42 mm	546221	VABV-S2-1HS-N38-T2
	D	1 valve position, 2 addresses, for double solenoid valves	52 mm	560843	VABV-S2-2S-N12-T2
	E	2 valve positions, 2 addresses, for single solenoid valves	18 mm	546216	VABV-S4-2HS-N18-2T1
	F	2 valve positions, 2 addresses, for single solenoid valves	26 mm	546212	VABV-S4-1HS-N14-2T1
	G	1 valve position, 1 address, for single solenoid valves	42 mm	546220	VABV-S2-1HS-N38-T1
	H	1 valve position, 1 address, for single solenoid valves	52 mm	560844	VABV-S2-2S-N12-T1

1) Code letter within the order code for a valve terminal configuration

Accessories – Pneumatic components

Ordering data – Duct separation/seal					
	Code	Description	Weight [g]	Part no.	Type
	S	Duct separation 1, 3, 5	57	539228	VABD-S6-1-P3-C
	T	Duct separation 1	43	539227	VABD-S6-1-P1-C
	R	Duct separation 3, 5	54	539229	VABD-S6-1-P2-C
	L	Seal between sub-bases, duct 1, 3, 5 open, port 14 blocked (colour coding: white)	40	573191	VABD-S6-1-P7-C
	TL	Seal between sub-bases, duct 1 blocked, port 14 blocked (colour coding: red) Note: additional pilot air supply required	43	8060483	VABD-S6-1-P8-C
	K	Seal between sub-bases, duct 1, 3, 5 blocked, port 14 blocked (colour coding: green)	57	8034612	VABD-S6-1-P6-C

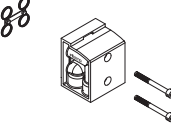
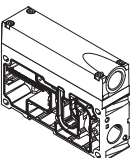
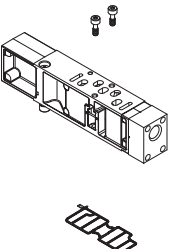
Ordering data					
	Code	Description	Width	Part no.	Type
Angled connection plate					
	P	Outlet at bottom, connecting thread 1/8 NPT	18 mm	539720	VABF-S4-2-A2G2-N18
		Outlet at bottom, connecting thread 1/4 NPT	26 mm	539722	VABF-S4-1-A2G2-N14
		Outlet at bottom, connecting thread 3/8 NPT	42 mm	546098	VABF-S2-1-A1G2-N38
		Outlet at bottom, connecting thread 1/2 NPT	52 mm	555703	VABF-S2-2-A1G2-N12
Supply plate					
	L	With exhaust plate, 3/5 common, 1/2 NPT		539233	VABF-S6-1-P1A7-N12
	K	With exhaust air cover, 3/5 separate, 1/2 NPT		539232	VABF-S6-1-P1A6-N12
Vertical supply plate (operating pressure 0.9...10 bar)					
	ZU	Connecting thread 1/8 NPT Individual compressed air supply, duct 1	18 mm	540174	VABF-S4-2-P1A3-N18
		Connecting thread 1/4 NPT Individual compressed air supply, duct 1	26 mm	540172	VABF-S4-1-P1A3-N14
		Connecting thread 3/8 NPT Individual compressed air supply, duct 1	42 mm	546094	VABF-S2-1-P1A3-N38
		Connecting thread 1/2 NPT Individual compressed air supply, duct 1	52 mm	555787	VABF-S2-2-P1A3-N12
	ZV	Connecting thread 1/8 NPT Individual compressed air supply, ducts 1 and 14	18 mm	8000694	VABF-S4-2-P1A14-N18
		Connecting thread 1/4 NPT Individual compressed air supply, ducts 1 and 14	26 mm	8000690	VABF-S4-2-P1A14-N14
		Connecting thread 3/8 NPT Individual compressed air supply, ducts 1 and 14	42 mm	8000540	VABF-S2-1-P1A14-N38
		Connecting thread 1/2 NPT Individual compressed air supply, ducts 1 and 14	52 mm	8000550	VABF-S2-2-P1A14-N12

Accessories – Pneumatic components

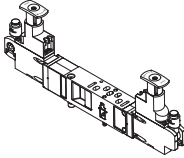
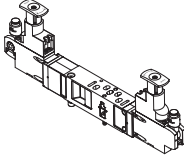
Ordering data – Vertical stacking							
	Code	Pressure regulation for port	Control range		Width	Part no.	Type
			[bar]	[MPa]			
Regulator plate, width 18 mm							
	ZA	1	0.5 ... 8.5	0.05 ... 0.85	18 mm	540153	VABF-S4-2-R1C2-C-10
	ZF	1	0.5 ... 6	0.05 ... 0.6	18 mm	540151	VABF-S4-2-R1C2-C-6
	ZC	2	2 ... 8.5	0.2 ... 0.85	18 mm	540161	VABF-S4-2-R2C2-C-10
	ZH	2	2 ... 6	0.2 ... 0.6	18 mm	540159	VABF-S4-2-R2C2-C-6
	ZB	4	2 ... 8.5	0.2 ... 0.85	18 mm	540157	VABF-S4-2-R3C2-C-10
	ZG	4	2 ... 6	0.2 ... 0.6	18 mm	540155	VABF-S4-2-R3C2-C-6
	ZD	2 and 4	2 ... 8.5	0.2 ... 0.85	18 mm	540165	VABF-S4-2-R4C2-C-10
	ZI	2 and 4	2 ... 6	0.2 ... 0.6	18 mm	540163	VABF-S4-2-R4C2-C-6
	ZE	2 and 4, reversible	0.5 ... 8.5	0.05 ... 0.85	18 mm	540169	VABF-S4-2-R5C2-C-10
	ZJ	2 and 4, reversible	0.5 ... 6	0.05 ... 0.6	18 mm	540167	VABF-S4-2-R5C2-C-6
	ZL	2, reversible	0.5 ... 8.5	0.05 ... 0.85	18 mm	546252	VABF-S4-2-R6C2-C-10
	ZN	2, reversible	0.5 ... 6	0.05 ... 0.6	18 mm	546248	VABF-S4-2-R6C2-C-6
	ZK	4, reversible	0.5 ... 8.5	0.05 ... 0.85	18 mm	546254	VABF-S4-2-R7C2-C-10
ZM	4, reversible	0.5 ... 6	0.05 ... 0.6	18 mm	546250	VABF-S4-2-R7C2-C-6	
Regulator plate, width 26 mm							
	ZA	1	0.5 ... 8.5	0.05 ... 0.85	26 mm	540154	VABF-S4-1-R1C2-C-10
	ZF	1	0.5 ... 6	0.05 ... 0.6	26 mm	540152	VABF-S4-1-R1C2-C-6
	ZC	2	2 ... 8.5	0.2 ... 0.85	26 mm	540162	VABF-S4-1-R2C2-C-10
	ZH	2	2 ... 6	0.2 ... 0.6	26 mm	540160	VABF-S4-1-R2C2-C-6
	ZB	4	2 ... 8.5	0.2 ... 0.85	26 mm	540158	VABF-S4-1-R3C2-C-10
	ZG	4	2 ... 6	0.2 ... 0.6	26 mm	540156	VABF-S4-1-R3C2-C-6
	ZD	2 and 4	2 ... 8.5	0.2 ... 0.85	26 mm	540166	VABF-S4-1-R4C2-C-10
	ZI	2 and 4	2 ... 6	0.2 ... 0.6	26 mm	540164	VABF-S4-1-R4C2-C-6
	ZE	2 and 4, reversible	0.5 ... 8.5	0.05 ... 0.85	26 mm	540170	VABF-S4-1-R5C2-C-10
	ZJ	2 and 4, reversible	0.5 ... 6	0.05 ... 0.6	26 mm	540168	VABF-S4-1-R5C2-C-6
	ZL	2, reversible	0.5 ... 8.5	0.05 ... 0.85	26 mm	546251	VABF-S4-1-R6C2-C-10
	ZN	2, reversible	0.5 ... 6	0.05 ... 0.6	26 mm	546247	VABF-S4-1-R6C2-C-6
	ZK	4, reversible	0.5 ... 8.5	0.05 ... 0.85	26 mm	546253	VABF-S4-1-R7C2-C-10
ZM	4, reversible	0.5 ... 6	0.05 ... 0.6	26 mm	546249	VABF-S4-1-R7C2-C-6	

Accessories – Pneumatic components

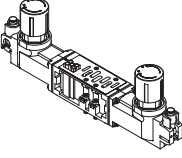
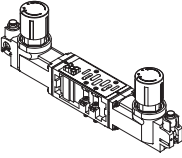
Ordering data – Vertical stacking							
	Code	Pressure regulation for port	Control range		Width	Part no.	Type
			[bar]	[MPa]			
Regulator plate, width 42 mm							
	ZA	1	0.5 ... 8.5	0.05 ... 0.85	42 mm	546084	VABF-S2-1-R1C2-C-10
	ZF	1	0.5 ... 6	0.05 ... 0.6	42 mm	546083	VABF-S2-1-R1C2-C-6
	ZC	2	1.0 ... 10	0.1 ... 1	42 mm	546088	VABF-S2-1-R2C2-C-10
	ZH	2	1.0 ... 6	0.1 ... 0.6	42 mm	546087	VABF-S2-1-R2C2-C-6
	ZB	4	1.0 ... 10	0.1 ... 1	42 mm	546086	VABF-S2-1-R3C2-C-10
	ZG	4	0.5 ... 6	0.05 ... 0.6	42 mm	546085	VABF-S2-1-R3C2-C-6
	ZD	2 and 4	1.0 ... 10	0.1 ... 1	42 mm	546090	VABF-S2-1-R4C2-C-10
	ZI	2 and 4	1.0 ... 6	0.1 ... 0.6	42 mm	546089	VABF-S2-1-R4C2-C-6
	ZE	2 and 4, reversible	0.5 ... 10	0.05 ... 1	42 mm	546092	VABF-S2-1-R5C2-C-10
	ZJ	2 and 4, reversible	0.5 ... 6	0.05 ... 0.6	42 mm	546091	VABF-S2-1-R5C2-C-6
	ZL	2, reversible	0.5 ... 10	0.05 ... 1	42 mm	546832	VABF-S2-1-R6C2-C-10
	ZN	2, reversible	0.5 ... 6	0.05 ... 0.6	42 mm	546831	VABF-S2-1-R6C2-C-6
	ZK	4, reversible	0.5 ... 10	0.05 ... 1	42 mm	546834	VABF-S2-1-R7C2-C-10
	ZM	4, reversible	0.5 ... 6	0.05 ... 0.6	42 mm	546833	VABF-S2-1-R7C2-C-6
Regulator plate, width 52 mm							
	ZA	1	0.5 ... 10	0.05 ... 1	52 mm	555772	VABF-S2-2-R1C2-C-10
	ZF	1	0.5 ... 6	0.05 ... 0.6	52 mm	555771	VABF-S2-2-R1C2-C-6
	ZC	2	1.0 ... 10	0.1 ... 1	52 mm	555774	VABF-S2-2-R2C2-C-10
	ZH	2	1.0 ... 6	0.1 ... 0.6	52 mm	555773	VABF-S2-2-R2C2-C-6
	ZB	4	1.0 ... 10	0.1 ... 1	52 mm	555776	VABF-S2-2-R3C2-C-10
	ZG	4	1.0 ... 6	0.1 ... 0.6	52 mm	555775	VABF-S2-2-R3C2-C-6
	ZD	2 and 4	1.0 ... 10	0.1 ... 1	52 mm	555778	VABF-S2-2-R4C2-C-10
	ZI	2 and 4	1.0 ... 6	0.1 ... 0.6	52 mm	555777	VABF-S2-2-R4C2-C-6
	ZE	2 and 4, reversible	0.5 ... 10	0.05 ... 1	52 mm	555780	VABF-S2-2-R5C2-C-10
	ZJ	2 and 4, reversible	0.5 ... 6	0.05 ... 0.6	52 mm	555779	VABF-S2-2-R5C2-C-6
	ZL	2, reversible	0.5 ... 10	0.05 ... 1	52 mm	555782	VABF-S2-2-R6C2-C-10
	ZN	2, reversible	0.5 ... 6	0.05 ... 0.6	52 mm	555781	VABF-S2-2-R6C2-C-6
	ZK	4, reversible	0.5 ... 10	0.05 ... 1	52 mm	555784	VABF-S2-2-R7C2-C-10
	ZM	4, reversible	0.5 ... 6	0.05 ... 0.6	52 mm	555783	VABF-S2-2-R7C2-C-6

Accessories – Pneumatic components

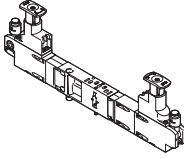
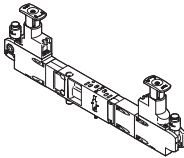
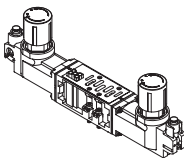
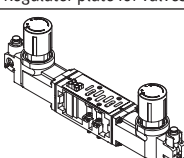







Ordering data – Vertical stacking							
	Code	Pressure regulation for port	Control range		Width	Part no.	Type
			[bar]	[MPa]			
Regulator plate for valves with symmetrical design, width 18 mm							
	ZAY	1	0.5 ... 8.5	0.05 ... 0.85	18 mm	560756	VABF-S4-2-R1C2-C-10E
	ZFY	1	0.5 ... 6	0.05 ... 0.6	18 mm	560758	VABF-S4-2-R1C2-C-6E
	ZCY	2	2 ... 8.5	0.2 ... 0.85	18 mm	560763	VABF-S4-2-R2C2-C-10E
	ZHY	2	2 ... 6	0.2 ... 0.6	18 mm	560765	VABF-S4-2-R2C2-C-6E
	ZDY	2 and 4	2 ... 8.5	0.2 ... 0.85	18 mm	560767	VABF-S4-2-R4C2-C-10E
	ZIY	2 and 4	2 ... 6	0.2 ... 0.6	18 mm	560769	VABF-S4-2-R4C2-C-6E
	ZEY	2 and 4, reversible	0.5 ... 8.5	0.05 ... 0.85	18 mm	560771	VABF-S4-2-R5C2-C-10E
	ZJY	2 and 4, reversible	0.5 ... 6	0.05 ... 0.6	18 mm	560773	VABF-S4-2-R5C2-C-6E
	ZLY	2, reversible	0.5 ... 8.5	0.05 ... 0.85	18 mm	560775	VABF-S4-2-R6C2-C-10E
	ZNY	2, reversible	0.5 ... 6	0.05 ... 0.6	18 mm	560777	VABF-S4-2-R6C2-C-6E
Regulator plate for valves with symmetrical design, width 26 mm							
	ZAY	1	0.5 ... 8.5	0.05 ... 0.85	26 mm	560757	VABF-S4-1-R1C2-C-10E
	ZFY	1	0.5 ... 6	0.05 ... 0.6	26 mm	549876	VABF-S4-1-R1C2-C-6E
	ZCY	2	2 ... 8.5	0.2 ... 0.85	26 mm	560764	VABF-S4-1-R2C2-C-10E
	ZHY	2	2 ... 6	0.2 ... 0.6	26 mm	560766	VABF-S4-1-R2C2-C-6E
	ZDY	2 and 4	2 ... 8.5	0.2 ... 0.85	26 mm	560768	VABF-S4-1-R4C2-C-10E
	ZIY	2 and 4	2 ... 6	0.2 ... 0.6	26 mm	560770	VABF-S4-1-R4C2-C-6E
	ZEY	2 and 4, reversible	0.5 ... 8.5	0.05 ... 0.85	26 mm	560772	VABF-S4-1-R5C2-C-10E
	ZJY	2 and 4, reversible	0.5 ... 6	0.05 ... 0.6	26 mm	560774	VABF-S4-1-R5C2-C-6E
	ZLY	2, reversible	0.5 ... 8.5	0.05 ... 0.85	26 mm	560776	VABF-S4-1-R6C2-C-10E
	ZNY	2, reversible	0.5 ... 6	0.05 ... 0.6	26 mm	560778	VABF-S4-1-R6C2-C-6E
Regulator plate for valves with symmetrical design, width 42 mm 1)							
	ZAY	1	0.5 ... 10	0.05 ... 1	42 mm	–	VABF-S2-1-R1C2-C-10E
	ZFY	1	0.5 ... 6	0.05 ... 0.6	42 mm	–	VABF-S2-1-R1C2-C-6E
	ZCY	2	0.5 ... 10	0.05 ... 1	42 mm	–	VABF-S2-1-R2C2-C-10E
	ZHY	2	0.5 ... 6	0.05 ... 0.6	42 mm	–	VABF-S2-1-R2C2-C-6E
	ZBY	4	0.5 ... 10	0.05 ... 1	42 mm	–	VABF-S2-1-R3C2-C-10E
	ZGY	4	0.5 ... 6	0.05 ... 0.6	42 mm	–	VABF-S2-1-R3C2-C-6E
	ZDY	2 and 4	0.5 ... 10	0.05 ... 1	42 mm	–	VABF-S2-1-R4C2-C-10E
	ZIY	2 and 4	0.5 ... 6	0.05 ... 0.6	42 mm	–	VABF-S2-1-R4C2-C-6E
	ZEY	2 and 4, reversible	0.5 ... 10	0.05 ... 1	42 mm	–	VABF-S2-1-R5C2-C-10E
	ZJY	2 and 4, reversible	0.5 ... 6	0.05 ... 0.6	42 mm	–	VABF-S2-1-R5C2-C-6E
	ZLY	2, reversible	0.5 ... 10	0.05 ... 1	42 mm	–	VABF-S2-1-R6C2-C-10E
	ZNY	2, reversible	0.5 ... 6	0.05 ... 0.6	42 mm	–	VABF-S2-1-R6C2-C-6E
	ZKY	4, reversible	0.5 ... 10	0.05 ... 1	42 mm	–	VABF-S2-1-R7C2-C-10E
	ZMY	4, reversible	0.5 ... 6	0.05 ... 0.6	42 mm	–	VABF-S2-1-R7C2-C-6E
Regulator plate for valves with symmetrical design, width 52 mm 1)							
	ZAY	1	0.5 ... 10	0.05 ... 1	52 mm	–	VABF-S2-2-R1C2-C-10E
	ZFY	1	0.5 ... 6	0.05 ... 0.6	52 mm	–	VABF-S2-2-R1C2-C-6E
	ZCY	2	0.5 ... 10	0.05 ... 1	52 mm	–	VABF-S2-2-R2C2-C-10E
	ZHY	2	0.5 ... 6	0.05 ... 0.6	52 mm	–	VABF-S2-2-R2C2-C-6E
	ZBY	4	0.5 ... 10	0.05 ... 1	52 mm	–	VABF-S2-2-R3C2-C-10E
	ZGY	4	0.5 ... 6	0.05 ... 0.6	52 mm	–	VABF-S2-2-R3C2-C-6E
	ZDY	2 and 4	0.5 ... 10	0.05 ... 1	52 mm	–	VABF-S2-2-R4C2-C-10E
	ZIY	2 and 4	0.5 ... 6	0.05 ... 0.6	52 mm	–	VABF-S2-2-R4C2-C-6E
	ZEY	2 and 4, reversible	0.5 ... 10	0.05 ... 1	52 mm	–	VABF-S2-2-R5C2-C-10E
	ZJY	2 and 4, reversible	0.5 ... 6	0.05 ... 0.6	52 mm	–	VABF-S2-2-R5C2-C-6E
	ZLY	2, reversible	0.5 ... 10	0.05 ... 1	52 mm	–	VABF-S2-2-R6C2-C-10E
	ZNY	2, reversible	0.5 ... 6	0.05 ... 0.6	52 mm	–	VABF-S2-2-R6C2-C-6E
	ZKY	4, reversible	0.5 ... 10	0.05 ... 1	52 mm	–	VABF-S2-2-R7C2-C-10E
	ZMY	4, reversible	0.5 ... 6	0.05 ... 0.6	52 mm	–	VABF-S2-2-R7C2-C-6E

1) These functions are only available via the pressure regulator configurator VABFS2 for width 42 mm and 52 mm only (ISO 5599-2, ISO 1 and ISO 2)

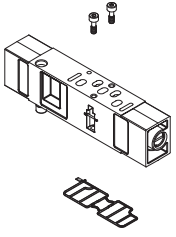
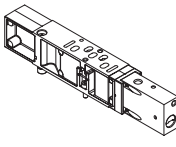
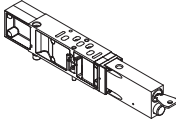
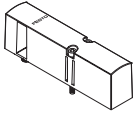
Accessories – Pneumatic components

Ordering data						
	Code	Description	Width	Part no.	Type	
Pressure gauge						
	T	With cartridge connection for regulator, 10 bar,	scale in bar/psi,	18 mm	543487	PAGN-26-16-P10
			display range 0...16 bar/0...240 psi,	26 mm		
			for regulator plate code ZA, ZB, ZC, ZD, ZE, ZK, ZL	42 mm	548010	PAGN-40-16-P10
				52 mm		
	U	With cartridge connection for regulator, 6 bar,	scale in bar/psi,	18 mm	543488	PAGN-26-10-P10
			display range 0...10 bar/0...145 psi,	26 mm		
			for regulator plate code ZF, ZG, ZH, ZI, ZJ, ZM, ZN	42 mm	548009	PAGN-40-10-P10
				52 mm		
	WT	With cartridge connection for regulator, 10 bar	Scale in MPa,	18 mm	563735	PAGN-26-1.6M-P10
			display range 0...16 bar/0...1.6 MPa,	26 mm		
			for regulator plate code ZA, ZB, ZC, ZD, ZE, ZK, ZL	42 mm	563737	PAGN-40-1.6M-P10
				52 mm		
	WU	With cartridge connection for regulator, 6 bar	Scale in MPa,	18 mm	563736	PAGN-26-1M-P10
			display range 0...16 bar/0...1 MPa	26 mm		
			for regulator plate code ZF, ZG, ZH, ZI, ZJ, ZM, ZN	42 mm	563738	PAGN-40-1M-P10
				52 mm		
	VT	With cartridge connection for regulator, 10 bar	Scale in psi/bar,	18 mm	563731	PAGN-26-232P-P10
			display range 0...16 bar/0...232 psi	26 mm		
for regulator plate code ZA, ZB, ZC, ZD, ZE, ZK, ZL			42 mm	563733	PAGN-40-232P-P10	
			52 mm			
PS	With cartridge connection for regulator, 6 bar	Scale in psi/bar,	18 mm	563732	PAGN-26-145P-P10	
		display range 0...10 bar/0...145 psi	26 mm			
		for regulator plate code ZF, ZG, ZH, ZI, ZJ, ZM, ZN	42 mm	563734	PAGN-40-145P-P10	
			52 mm			

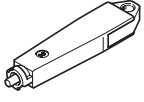

Accessories – Pneumatic components

Ordering data		Code	Description	Part no.	Type
Cartridge for regulator plate					
	–	For tubing O.D. 4 mm	Pack of 1	172972	QSP10-4
	–	Adapter for pressure gauge (allows products with threaded connection G1/8 to be attached to the cartridge connection)	Pack of 6	565811	QSP10-G1/8
Throttle plate					
	X	Restricts the exhaust air downstream of the valve in ducts 3 and 5	18 mm	540176	VABF-S4-2-F1B1-C
			26 mm	540175	VABF-S4-1-F1B1-C
			42 mm	546095	VABF-S2-1-F1B1-C
			52 mm	555789	VABF-S2-2-F1B1-C
Vertical pressure shut-off plate					
	ZT	3/2-way valve for shutting off the operating pressure at the valve position Pressure separation can be shut off on the valve assembly	18 mm	542884	VABF-S4-2-L1D1-C
			26 mm	542885	VABF-S4-1-L1D1-C
			42 mm	546096	VABF-S2-1-L1D1-C
			52 mm	555791	VABF-S2-2-L1D1-C
	ZS	3/2-way valve for shutting off the operating pressure at the valve position Pressure separation can be shut off on the valve assembly using a key	18 mm	8001178	VABF-S4-2-L1D2-C
			26 mm	8001179	VABF-S4-1-L1D2-C
Covering					
	L	Blanking plate for vacant position	18 mm	539213	VABB-S4-2-WT
			26 mm	539212	VABB-S4-1-WT
			42 mm	543186	VABB-S2-1-WT
			52 mm	560845	VABB-S2-2-WT
	N	Cover cap for manual override, non-detenting	Pack of 10	541010	VAMC-S6-CH
	V	Cover cap for manual override, concealed	Pack of 10	541011	VAMC-S6-CS
	A	Cover cap, heavy duty, for manual override, non-detenting heavy duty, detenting via accessory (key) (The cover cap is provided for one-off mounting only)	Pack of 10	4105147	VAMC-B-S6-CTR
	–	Sealing cap for electrical links (with individual connection), size 18 mm and 26 mm	Pack of 10	547713	VABD-S4-E-C
	–	Seal (with individual connection), width 42 mm and 52 mm	Pack of 2	571343	VABD-S2-1-S-C
Accessories for manual override, heavy duty					
	–	Coded key (accessory) for actuating the cover cap, heavy duty, for detenting position (VAMC-B-S6-CTR)	Pack of 1	1662543	AHB-MEB-B

 **Note**

There is a wide range of preconfigured solenoid valves with cover cap for manual override and correct valve type code available to order in the sections on solenoid valves.

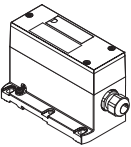

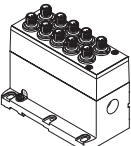
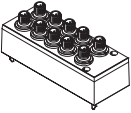
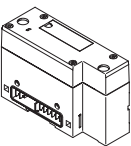
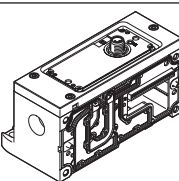
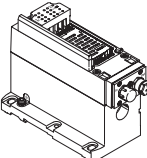
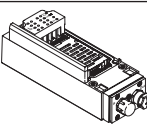

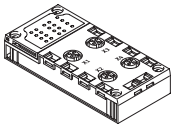
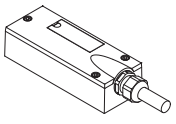
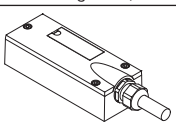
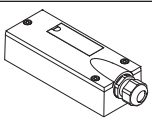

Accessories – Electrical components

Ordering data		Code	Description	Part no.	Type
Multi-pin node for VTSA/VTSA-F					
	T	Terminal strip, 36-pin	 Note Multi-pin node supplied without cover. Please order appropriate cover with cable separately.	543412	VABE-S6-1LF-C-M1-C36M
	MP1	Sub-D plug, 37-pin		543414	VABE-S6-1LT-C-M1-S37
	MP4	Round plug, 19-pin		543415	VABE-S6-1LF-C-M1-R19
Individual electrical connection for VTSA/VTSA-F					
	-MP2	Multi-pin node with individual connection M12, 6-way		549046	VABE-S6-LT-C-S6-R5
	-MP3	Multi-pin node with individual connection M12, 10-way		549047	VABE-S6-LT-C-S10-R5
	-	Cover for individual connection M12, 6-way		549048	VAEM-S6-C-S6-R5
	-	Cover for individual connection M12, 10-way		549049	VAEM-S6-C-S10-R5
Pneumatic interface for VTSA/VTSA-F					
	-	For electrical terminal CPX in polymer		543416	VABA-S6-1-X1
	-	For electrical terminal CPX in metal		550663	VABA-S6-1-X2
	-	For electrical terminal CPX in metal, with changed diagnostic function		573613	VABA-S6-1-X2-D
Electrical interface IO-Link®					
	-	IO-Link® interface for 16 valve positions		8152353	VABA-S6-1-PT
Electrical interface for AS-Interface for VTSA/VTSA-F					
	-	4 inputs/4 outputs		549042	VABE-S6-1LF-C-A4-E
	-	8 inputs/8 outputs		549043	VABE-S6-1LF-C-A8-E
AS-Interface module for VTSA/VTSA-F					
	-	4 inputs/4 outputs		549044	VAEM-S6-S-FAS-4-4E
	-	8 inputs/8 outputs		549045	VAEM-S6-S-FAS-8-8E

Accessories – Electrical components

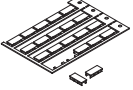
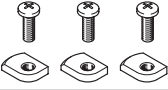
Ordering data					
	Code	Description	Part no.	Type	
Connection block for AS-Interface					
	X	4x M12, 5-pin, double, socket	195704	CPX-AB-4-M12x2-5POL	
	GW	4x M12, 5-pin, socket, metal thread	541254	CPX-AB-4-M12x2-5POL-R	
	R	8x M8, 3-pin, socket	195706	CPX-AB-8-M8-3POL	
	J	8x spring-loaded terminal, Cage Clamp, 4-pin	195708	CPX-AB-8-KL-4POL	
	B	Sub-D, 25-pin, socket	525676	CPX-AB-1-SUB-BU-25POL	
Connecting cable, Sub-D (TPE-U(PUR), IP65)					
	GA	Connecting cable for max. 8 solenoid coils, 10-core	2.5 m	539240	NEBV-S1W37-E-2.5-LE10
	GB		5 m	539241	NEBV-S1W37-E-5-LE10
	GC		10 m	539242	NEBV-S1W37-E-10-LE10
	GD	Connecting cable for max. 22 solenoid coils, 26-core	2.5 m	539243	NEBV-S1W37-E-2.5-LE26
	GE		5 m	539244	NEBV-S1W37-E-5-LE26
	GF		10 m	539245	NEBV-S1W37-E-10-LE26
	GG	Connecting cable for max. 32 solenoid coils, 37-core	2.5 m	539246	NEBV-S1W37-K-2.5-LE37
	GH		5 m	539247	NEBV-S1W37-K-5-LE37
	GI		10 m	539248	NEBV-S1W37-K-10-LE37
Connecting cable, Sub-D (PVC, IP65)					
	GK	Connecting cable for max. 8 solenoid coils, 10-core	2.5 m	543271	NEBV-S1W37-KM-2.5-LE10
	GL		5 m	543272	NEBV-S1W37-KM-5-LE10
	GM		10 m	543273	NEBV-S1W37-KM-10-LE10
	GN	Connecting cable for max. 23 solenoid coils, 27-core	2.5 m	543274	NEBV-S1W37-KM-2.5-LE27
	GO		5 m	543275	NEBV-S1W37-KM-5-LE27
	GP		10 m	543276	NEBV-S1W37-KM-10-LE27
	GQ	Connecting cable for max. 32 solenoid coils, 37-core	2.5 m	543277	NEBV-S1W37-KM-2.5-LE37
	GR		5 m	543278	NEBV-S1W37-KM-5-LE37
	GS		10 m	543279	NEBV-S1W37-KM-10-LE37
Cover for multi-pin plug					
	–	For configuration by the user	545974	NECV-S1W37	

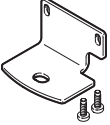
Accessories – General

Ordering data					
	Code	Description		Part no.	Type
Inscription label holders/inscription labels					
	B	Clip-on inscription label holder for valve cap	Pack of 5	540888	ASCF-T-S6
	T	Inscription label holder for manifold blocks	Pack of 5	540889	ASCF-M-S6
	TD	Inscription label holder for manifold blocks, size 52 mm	Pack of 5	562577	ASCF-M-S2-2
	–	Inscription label for ISO 15407 valves with individual electrical connection (20 labels in frames)	20 pieces	18182	IBS-9x20
	–	Inscription label for pressure zone separation <ul style="list-style-type: none"> • 4 inscription labels, duct 1/3/5 blocked • 4 inscription labels, duct 1 blocked • 4 inscription labels, duct 3/5 blocked 	Pack of 3x4	8003303	ASLR-L-S6-2016
DIN rail mounting					
	–	VTSA/VTSA-F	Pack of 3	526032	CPX-CPA-BG-NRH
Wall mounting					
	–	Mounting bracket with a mounting hole for M5 screw	Pack of 5	539214	VAME-S6-10-W
	U	Mounting bracket with a mounting hole for M4 screw and a mounting hole for M6 screw	Pack of 1	567038	VAME-S6-W-M46
	AW	Mounting bracket for length compensation on the CPX side when mounting using support system Set comprising 1 angle bracket and 2 screws	Pack of 1	2721419	CPX-M-BG-VT-2X
User documentation					
	D	User documentation for valve terminal VTSA/VTSA-F	German	538922	VTSA/VTSA-F-DE
	E		English	538923	VTSA/VTSA-F-EN
Pneumatic connection accessories					
A selection of possible fittings, blanking plugs, silencers and other pneumatic accessories can be found in the chapter "Accessories" → page 190 or on the website via the individual search terms: Internet → connection technology, silencer, blanking plug					

Datasheet – Solenoid valve with switching position sensing

Function¹⁾

Valves with code S0, SQ, SS,
width 18 mm

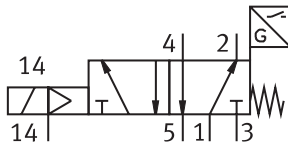

Valves with code S0, SQ, SS,
width 26 mm

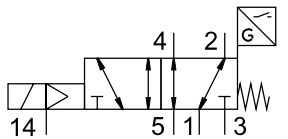

-  - Flow rate
up to 1100 l/min

-  - Valve width
18 mm
26 mm

-  - Voltage
24 V DC

-  - Operating pressure
0.3 ... 1 MPa
3 ... 10 bar

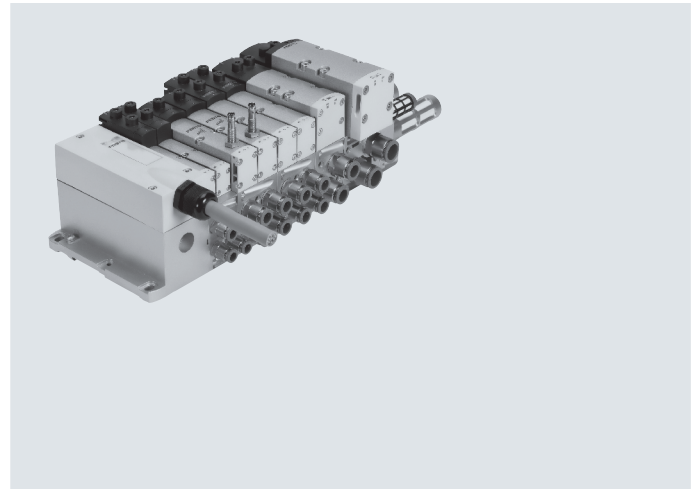

ISO valves with switching position sensing for safety-related pneumatic components

Function

The single solenoid 5/2-way valve with spring return in width 18 mm and 26 mm features valve diagnostics. It is available as a valve with plug-in or individual connection with pilot valves to ISO 15218 and square plug type C.

The normal position of the piston spool is monitored by the inductive sensor. This valve is not a safety device in accordance with the Machinery Directive 2006/42/EC. When used in higher categories, the sensor signal from the valve must be evaluated by the control system.

This valve is suitable for use in safety-related parts of control systems to EN ISO 13849-1. The control block has been developed and manufactured in accordance with the basic and proven safety principles of EN ISO 13849-2.

This valve is designed for installation in machines and automation systems and must only be used in industrial applications (high-demand mode).

Decentralised individual connection variant

Valve on individual sub-base (square plug or plug-in) with integrated switching position sensing.

The electrical connection is established via either a standardised 4-pin M12 plug 24 V DC (ISO 15407-2), a 4-pin spring-loaded terminal or a cable (open end) 24 V DC, which can be configured by the user.

The individual sub-base can be supplied with internal or external pilot air depending on the version.

Variant for valve terminal VTSA/VTSA-F

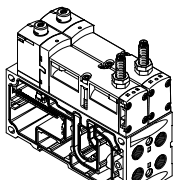

The valves with integrated switching position sensing in plug-in design for valve terminal VTSA/VTSA-F can be used regardless of the type of electrical actuation (individual, multi-pin plug or fieldbus/control block connection).

Pilot air supply:
The valve terminal can be supplied with internal or external pilot air via the various end plate variants.

-  - **Note**
Valves in plug-in design are always supplied with pilot air via duct 14 in the manifold sub-base.

1) The circuit diagram represents a valve with a proximity switch with a N/O switching output signal. This symbol applies to both N/O and N/C contacts, in accordance with ISO 1219-1. The switching element function of the sensors used here is designed as an N/C contact.

-  - **Note**

Pilot exhaust air port 12 is exhausted directly at the valve, without a connection. If the customer requests a "turned seal", the exhaust air is vented at the end plates of the valve terminal, which doesn't conform to the ISO standard.

Datasheet – Solenoid valve with switching position sensing

Safety characteristics	
Conforms to standard	EN 13849-1/2
CE marking (see declaration of conformity)	To EU EMC Directive 1)
Shock resistance	Shock test with severity level 2, to EN 60068-2-27
Vibration resistant	Transport application test with severity level 2, to EN 60068-2-6

1) For information about the area of use, see the EC declaration of conformity at: www.festo.com/sp → Certificates.
If the devices are subject to usage restrictions in residential, commercial or light-industrial environments, further measures for the reduction of the emitted interference may be necessary.

Safety characteristics		
Valve function 5/2-way, single solenoid	Test pulses	
	Max. positive test pulse with logic 0 [µs]	Max. negative test pulse with logic 1 [µs]
VSVA-B-M52-MZ...-A1-1T1L- ...	1200	1100
VSVA-B-M52-MZ...-A2-1T1L- ...	1500	800
VSVA-B-M52-MZ-A1-1C1- ...	1800	800

General technical data			
Valve	VSVA-B-M52-MZD-A2-1T1L-...	VSVA-B-M52-MZD-A1-1T1L-...	VSVA-B-M52-MZ-A1-1C1-...
Width	18 mm	26 mm	26 mm
Conforms to	ISO 15407-2		ISO 15407-1
Design	Piston spool valve		
Sealing principle	Soft		
Overlap	Positive overlap		
Actuation type	Electrical		
Type of control	Piloted		
Exhaust function, can be throttled	Via individual sub-base, via throttle plate		
Lubrication	Lifetime lubrication		
Type of mounting	Via through-hole, on manifold sub-base		
Mounting position	Any		
Manual override	Concealed		
Individual sub-base			→ Page 181
Valve terminal			→ Page 73

Standard nominal flow rate [l/min]				
Valve function	Flow rate			
	Valve	Valve on valve terminal VTSA	Valve on valve terminal VTSA-F	Valve on individual sub-base
VSVA-B-M52-MZ-A1-1C1-ANC	1400	1100	–	1100
VSVA-B-M52-MZ-A1-1C1-ANP	1400	1100	–	1100
VSVA-B-M52-MZ-A1-1C1-APC	1400	1100	–	1100
VSVA-B-M52-MZ-A1-1C1-APP	1400	1100	–	1100
VSVA-B-M52-MZD-A1-1T1L-ANC	1400	1100	1350	1200
VSVA-B-M52-MZD-A1-1T1L-ANP	1400	1100	1350	1200
VSVA-B-M52-MZD-A1-1T1L-APC	1400	1100	1350	1200
VSVA-B-M52-MZD-A1-1T1L-APP	1400	1100	1350	1200
VSVA-B-M52-MZD-A1-1T1L-APX-0.5	1400	1100	1350	1200
VSVA-B-M52-MZD-A2-1T1L-ANP	750	550	700	600
VSVA-B-M52-MZD-A2-1T1L-APP	750	550	700	600
VSVA-B-M52-MZD-A2-1T1L-APX-0.5	750	550	700	600

Datasheet – Solenoid valve with switching position sensing

Valve switching times [ms]				
Valve		VSVA-B-M52-MZD-A2-1T1L-...	VSVA-B-M52-MZD-A1-1T1L-...	VSVA-B-M52-MZ-A1-1C1-...
Width		18 mm	26 mm	26 mm
Switching times, valve	On	12	20	21
	Off	38	54	41
Switching times, sensor	On	32	60	60
	Off	9	11	11

Electrical data – Valve				
Valve		VSVA-B-M52-MZD-A2-1T1L-...	VSVA-B-M52-MZD-A1-1T1L-...	VSVA-B-M52-MZ-A1-1C1-...
Width		18 mm	26 mm	26 mm
Electrical connection		4-pin plug to ISO 15407-2		Plug to EN 175301-803, type C, without PE conductor
Nominal operating voltage	[V DC]	24		
Permissible voltage fluctuations	[%]	±10		-15/+10
Surge resistance	[kV]	2.5		
Pollution degree		3		
Power consumption	[W]	1.6		1.8
Switching position sensing		Normal position via sensor		
Duty cycle		100		
Degree of protection to EN 60529		IP65, NEMA 4 (for all types of signal transmission when mounted)		
Signal status indication		LED		Via accessories

Electrical data – Sensor				
Electrical connection		Cable, 3-core 1x M8 plug, 3-pin		
Cable length	[m]	2.5		
Switching output		PNP or NPN		
Switching element function		N/C		
Switching status indication		Yellow LED		
Operating voltage range	[V DC]	10 ... 30		
Residual ripple	[%]	±10		
Sensor no-load current	[mA]	≤10		
Maximum output current	[mA]	200		
Voltage drop	[V]	≤2		
Max. switching frequency	[Hz]	5000		
Short circuit current rating		Pulsed		
Reverse polarity protection for sensor		For all electrical connections		
Measuring principle		Inductive		
Switching position sensing		Valve normal position via sensor		

Datasheet – Solenoid valve with switching position sensing

Operating and environmental conditions			
Valve	VSVA-B-M52-...-1T1L-...	VSVA-B-M52-...-1C1-...	
Operating medium	Compressed air to ISO 8573-1:2010 [7:4:4]		
Notes on operating/ Pilot medium	Lubricated operation possible (in which case lubricated operation will always be required)		
Operating pressure	[bar]	-0.9 ... 10	-0.9 ... 16
	[MPa]	-0.09 ... 1	-0.09 ... 1.6
Operating pressure for valve terminal with internal pilot air supply	[bar]	3 ... 10	
	[MPa]	0.3 ... 1	
Pilot pressure	[bar]	3 ... 10	
	[MPa]	0.3 ... 1	
Ambient temperature	[°C]	-5 ... +50	
Temperature of medium	[°C]	-5 ... +50	
Note on materials	RoHS-compliant		
Noise level LpA	[dB(A)]	85	
CE marking (see declaration of conformity)	To EU EMC Directive ¹⁾		
UKCA marking (see declaration of conformity)	To UK EMC regulations ¹⁾		
KC marking	KC EMC		
Certification	C-Tick		C-Tick
	c UL us – Recognized (OL)		–

1) For information about the area of use, see the EC declaration of conformity at: [www.festo.com/catalogue/... d Support/Downloads](http://www.festo.com/catalogue/...d/Support/Downloads).
If the devices are subject to usage restrictions in residential, commercial or light-industrial environments, further measures for the reduction of the emitted interference may be necessary.

Materials	
Sub-base/manifold sub-base	Die-cast aluminium
Valve	Die-cast aluminium, PA
Seals	FPM, NBR
Screws	Galvanised steel
Sensor housing	High-alloy stainless steel
Sensor cable sheath	TPE-U(PUR)

Product weight		
Width	18 mm	26 mm
5/2-way solenoid valve type		
VSVA-B-M52-MZD-A2-1T1L-APX-0.5	157 g	–
VSVA-B-M52-MZD-A2-1T1L-APP	140 g	–
VSVA-B-M52-MZD-A2-1T1L-ANP	140 g	–
VSVA-B-M52-MZD-A1-1T1L-APC	–	307 g
VSVA-B-M52-MZD-A1-1T1L-APP	–	264 g
VSVA-B-M52-MZ-A1-1C1-APC	–	332 g
VSVA-B-M52-MZ-A1-1C1-APP	–	289 g
VSVA-B-M52-MZD-A1-1T1L-ANC	–	307 g
VSVA-B-M52-MZD-A1-1T1L-ANP	–	264 g
VSVA-B-M52-MZ-A1-1C1-ANC	–	332 g
VSVA-B-M52-MZ-A1-1C1-ANP	–	289 g
VSVA-B-M52-MZD-A1-1T1L-APX-0.5	–	281 g
Individual connection		
Individual sub-base	192	302 g

Datasheet – Solenoid valve with switching position sensing

Dimensions

Download CAD data → www.festo.com

Solenoid valve with sensor, width 26 mm

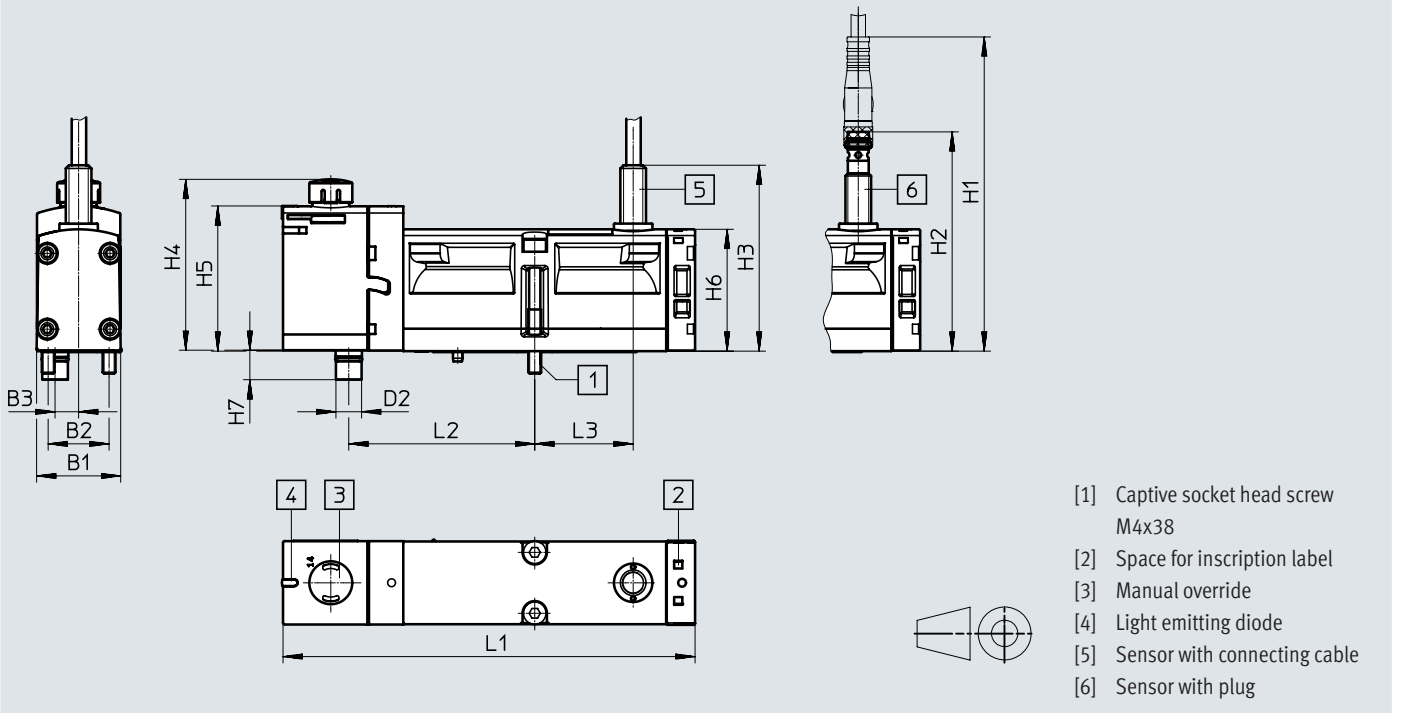

Type	B1	B2	B3	D2	L1	L2	L3
VSVA-B-M52-MZD-A1-1T1L...	26.2	19	7.4	8	128.9	58	30.7
VSVA-B-M52-MZD-A1-1T1L-APX-0.5							

Type	H1	H2	H3	H4	H5	H6	H7
VSVA-B-M52-MZD-A1-1T1L...	98	68.2	58	52.5	45.3	38	9.2
VSVA-B-M52-MZD-A1-1T1L-APX-0.5							

Datasheet – Solenoid valve with switching position sensing

Dimensions

Download CAD data → www.festo.com

Solenoid valve with sensor, with plug type C, width 26 mm

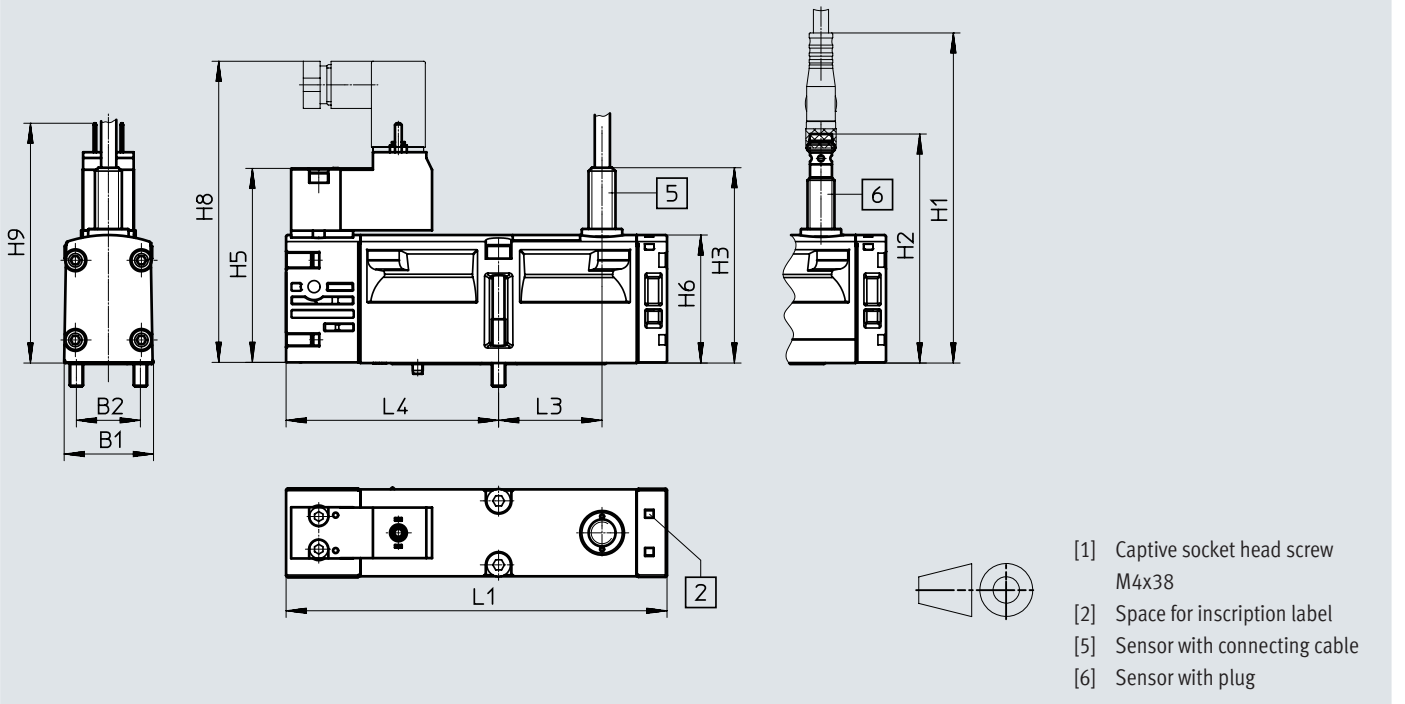

Type	B1	B2	L1	L3	L4
VSVA-B-M52-MZ-A1-1C1-...	26.2	19	113.1	30.7	63.1

Type	H1	H2	H3	H5	H6	H8	H9
VSVA-B-M52-MZ-A1-1C1-...	98	68.2	58	57.8	38	89.6	71.2

Ordering data – Solenoid valve with switching position sensing

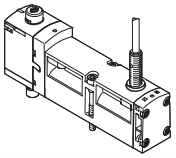
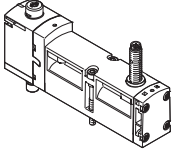
Ordering data – Solenoid valve VSVA, manual override non-detenting/detenting (D)					
	Code	Valve function	Width	Part no.	Type
5/2-way solenoid valve, 24 V DC, plug-in design for valve terminal VTSA/VTSA-F with proximity switch					
	–	5/2-way valve, single solenoid, mechanical spring return, inductive sensor with PNP output and cable, 3-core, 2.5 m	26 mm	560723	VSVA-B-M52-MZD-A1-1T1L-APC
	–	5/2-way valve, single solenoid, mechanical spring return, inductive sensor with NPN output and cable, 3-core, 2.5 m	26 mm	560742	VSVA-B-M52-MZD-A1-1T1L-ANC
	SS	5/2-way valve, single solenoid, mechanical spring return, inductive sensor with PNP output with 0.5 m connecting cable and 4-pin sensor push-in connector M12x1	18 mm	573201	VSVA-B-M52-MZD-A2-1T1L-APX-0.5
			26 mm	570850	VSVA-B-M52-MZD-A1-1T1L-APX-0.5
	SO	5/2-way valve, single solenoid, mechanical spring return, inductive sensor with PNP output and 3-pin sensor push-in connector M8x1	18 mm	573202	VSVA-B-M52-MZD-A2-1T1L-APP
			26 mm	560724	VSVA-B-M52-MZD-A1-1T1L-APP
SQ	5/2-way valve, single solenoid, mechanical spring return, inductive sensor with NPN output and 3-pin sensor push-in connector M8x1	18 mm	573203	VSVA-B-M52-MZD-A2-1T1L-ANP	
		26 mm	560743	VSVA-B-M52-MZD-A1-1T1L-ANP	

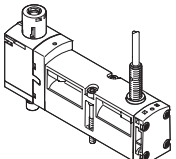
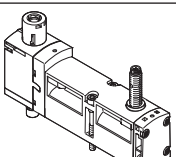
Ordering data – Solenoid valve VSVA with cover cap for manual override non-detenting/heavy duty, detenting via accessory (TR)					
	Code	Valve function	Width	Part no.	Type
5/2-way solenoid valve, 24 V DC, plug-in design for valve terminal VTSA/VTSA-F with proximity switch					
	–	5/2-way valve, single solenoid, mechanical spring return, inductive sensor with PNP output and cable, 3-core, 2.5 m	26 mm	8033026	VSVA-B-M52-MZTR-A1-1T1L-APC
	–	5/2-way valve, single solenoid, mechanical spring return, inductive sensor with NPN output and cable, 3-core, 2.5 m	26 mm	8033030	VSVA-B-M52-MZTR-A1-1T1L-ANC
	SS	5/2-way valve, single solenoid, mechanical spring return, inductive sensor with PNP output with 0.5 m connecting cable and 4-pin sensor push-in connector M12x1	18 mm	8033459	VSVA-B-M52-MZTR-A2-1T1L-APX-0.5
			26 mm	8033034	VSVA-B-M52-MZTR-A1-1T1L-APX-0.5
	SO	5/2-way valve, single solenoid, mechanical spring return, inductive sensor with PNP output and 3-pin sensor push-in connector M8x1	18 mm	8033460	VSVA-B-M52-MZTR-A2-1T1L-APP
			26 mm	8033027	VSVA-B-M52-MZTR-A1-1T1L-APP
SQ	5/2-way valve, single solenoid, mechanical spring return, inductive sensor with NPN output and 3-pin sensor push-in connector M8x1	18 mm	8033461	VSVA-B-M52-MZTR-A2-1T1L-ANP	
		26 mm	8033031	VSVA-B-M52-MZTR-A1-1T1L-ANP	

Ordering data – Solenoid valve with switching position sensing

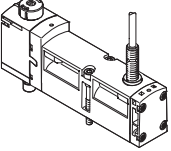
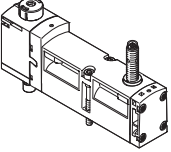
Ordering data – Solenoid valve VSVA with cover cap for manual override, non-detenting (H)					
	Code	Valve function	Width	Part no.	Type
5/2-way solenoid valve, 24 V DC, plug-in design for valve terminal VTSA/VTSA-F with proximity switch					
	–	5/2-way valve, single solenoid, mechanical spring return, inductive sensor with PNP output and cable, 3-core, 2.5 m	26 mm	8033049	VSVA-B-M52-MZH-A1-1T1L-APC
	–	5/2-way valve, single solenoid, mechanical spring return, inductive sensor with NPN output and cable, 3-core, 2.5 m	26 mm	8033053	VSVA-B-M52-MZH-A1-1T1L-ANC
	SS	5/2-way valve, single solenoid, mechanical spring return, inductive sensor with PNP output with 0.5 m connecting cable and 4-pin sensor push-in connector M12x1	18 mm	8033477	VSVA-B-M52-MZH-A2-1T1L-APX-0.5
			26 mm	8033057	VSVA-B-M52-MZH-A1-1T1L-APX-0.5
	SO	5/2-way valve, single solenoid, mechanical spring return, inductive sensor with PNP output and 3-pin sensor push-in connector M8x1	18 mm	8033478	VSVA-B-M52-MZH-A2-1T1L-APP
			26 mm	8033050	VSVA-B-M52-MZH-A1-1T1L-APP
	SQ	5/2-way valve, single solenoid, mechanical spring return, inductive sensor with NPN output and 3-pin sensor push-in connector M8x1	18 mm	8033479	VSVA-B-M52-MZH-A2-1T1L-ANP
26 mm			8033054	VSVA-B-M52-MZH-A1-1T1L-ANP	

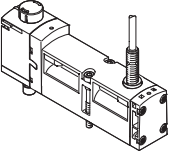
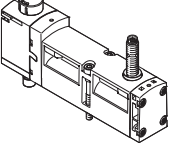
Ordering data – Solenoid valve VSVA with cover cap for manual override, concealed					
	Code	Valve function	Width	Part no.	Type
5/2-way solenoid valve, 24 V DC, plug-in design for valve terminal VTSA/VTSA-F with proximity switch					
	–	5/2-way valve, single solenoid, mechanical spring return, inductive sensor with PNP output and cable, 3-core, 2.5 m	26 mm	8033072	VSVA-B-M52-MZ-A1-1T1L-APC
	–	5/2-way valve, single solenoid, mechanical spring return, inductive sensor with NPN output and cable, 3-core, 2.5 m	26 mm	8033076	VSVA-B-M52-MZ-A1-1T1L-ANC
	SS	5/2-way valve, single solenoid, mechanical spring return, inductive sensor with PNP output with 0.5 m connecting cable and 4-pin sensor push-in connector M12x1	18 mm	8033495	VSVA-B-M52-MZ-A2-1T1L-APX-0.5
			26 mm	8033080	VSVA-B-M52-MZ-A1-1T1L-APX-0.5
	SO	5/2-way valve, single solenoid, mechanical spring return, inductive sensor with PNP output and 3-pin sensor push-in connector M8x1	18 mm	8033496	VSVA-B-M52-MZ-A2-1T1L-APP
			26 mm	8033073	VSVA-B-M52-MZ-A1-1T1L-APP
	SQ	5/2-way valve, single solenoid, mechanical spring return, inductive sensor with NPN output and 3-pin sensor push-in connector M8x1	18 mm	8033497	VSVA-B-M52-MZ-A2-1T1L-ANP
26 mm			8033077	VSVA-B-M52-MZ-A1-1T1L-ANP	

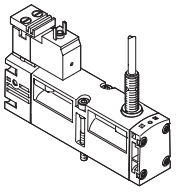
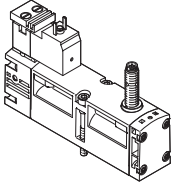

Ordering data – Solenoid valve with switching position sensing

Ordering data	Code	Valve function	Width	Part no.	Type
Solenoid valves, 24 V DC, with pneumatic interface to ISO 15218 for individual sub-base					
	–	5/2-way valve, single solenoid, mechanical spring return, inductive sensor with PNP output and cable, 3-core, 2.5 m, electrical connection to EN 175301-803, type C	26 mm	560725	VSVA-B-M52-MZ-A1-1C1-APC
	–	5/2-way valve, single solenoid, mechanical spring return, inductive sensor with NPN output and cable, 3-core, 2.5 m, electrical connection to EN 175301-803, type C	26 mm	560744	VSVA-B-M52-MZ-A1-1C1-ANC
	–	5/2-way valve, single solenoid, mechanical spring return, inductive sensor with PNP output and 3-pin sensor push-in connector M8x1, electrical connection to EN 175301-803, type C	26 mm	560726	VSVA-B-M52-MZ-A1-1C1-APP
	–	5/2-way valve, single solenoid, mechanical spring return, inductive sensor with NPN output and 3-pin sensor push-in connector M8x1, electrical connection to EN 175301-803, type C	26 mm	560745	VSVA-B-M52-MZ-A1-1C1-ANP



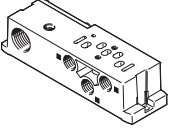

 **Note**

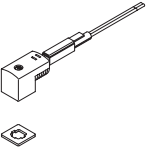
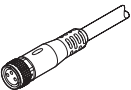
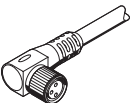
- The sensors integrated in the valves must not be replaced by the customer. Incorrect assembly can result in malfunctions or damage to the valve. Return the module to Festo for repair in the event of a fault.
- Valves with switching position sensing from the VSVA-B-M52-... series can only be ordered individually. If these are used on a valve terminal, appropriate vacant positions must be provided for them. Exceptions are the valves with ident. code SS, SO and SQ.

Accessories – Solenoid valve with switching position sensing

Ordering data		Code	Description	Part no.	Type
Individual sub-base, port pattern to ISO 15407-2, electrical connection via cable clamps					
	–	Threaded connection, internal pilot air supply, lateral connections	18 mm	541068	VABS-S4-2S-N18-B-K2
			26 mm	541066	VABS-S4-1S-N14-B-K2
	–	Threaded connection, external pilot air supply, lateral connections	18 mm	539724	VABS-S4-2S-N18-K2
			26 mm	539726	VABS-S4-1S-N14-K2
Plug socket for the electrical connection of individual valves, type C					
	–	<ul style="list-style-type: none"> • Angled socket, type C, 3-pin • Straight plug, PG7 • 230 V AC 		151687	MSSD-EB
			<ul style="list-style-type: none"> • Angled socket, type C, 3-pin • Straight plug, M12x1 		539712
Illuminating seal for plug pattern to EN 175301-803, type C				Datasheets → Internet: meb-ld	
	–	For plug socket MSSD, 12 ... 24 V DC		151717	MEB-LD-12-24DC
Connecting cable for electrical connection of individual valves, type C					
	GG	• Angled socket, type C, 3-pin, with LED	2.5 m	151688	KMEB-1-24-2.5-LED
	GH	• Open end, 3-core	5 m	151689	KMEB-1-24-5-LED
	GJ	• 24 V DC, PVC	10 m	193457	KMEB-1-24-10-LED
Connecting cable for the electrical connection of sensors for switching position sensing					
	GM	• Straight socket, M8x1, 3-pin	2.5 m	8078223	NEBA-M8G3-U-2.5-N-LE3
	GN	• Straight socket, M8x1, 3-pin	5 m	8078224	NEBA-M8G3-U-5-N-LE3
	GO	• Angled socket, M8x1, 3-pin	2.5 m	8078230	NEBA-M8W3-U-2.5-N-LE3
	GP	• Angled socket, M8x1, 3-pin	5 m	8078231	NEBA-M8W3-U-5-N-LE3
	–	• Angled socket, rotatable, M8x1, 3-pin	2.5 m	8001660	NEBU-M8R3-K-2.5-LE3
	–	• Angled socket, rotatable, M8x1, 3-pin	5 m	8001661	NEBU-M8R3-K-5-LE3
Pneumatic connection accessories					
A selection of possible fittings, blanking plugs, silencers and other pneumatic accessories can be found in the chapter "Accessories" → page: 190 or on the website using the individual search terms:					
Internet → connection technology, silencer, blanking plug					

Datasheet – Control block with safety function

-  - Flow rate
on valve terminal: 830 l/min
-  - Solenoid valve width
26 mm
-  - Voltage
24 V DC
-  - Operating pressure
0.3 ... 1 MPa
3 ... 10 bar

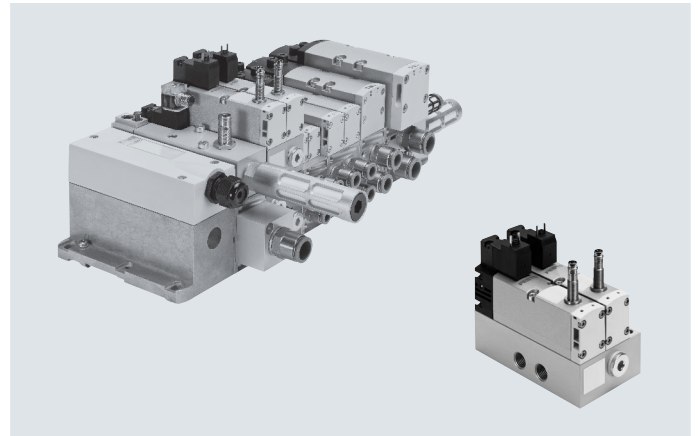

Description

The control block is designed for two-channel control of pneumatic drive components such as double-acting linear cylinders and can be used to realise the following protective measures:

- Protection against unexpected start-up (EN 1037)
- Reversing hazardous movements, provided the reversing motion will not result in further hazards

Version for valve terminal VTSA/VTSA-F

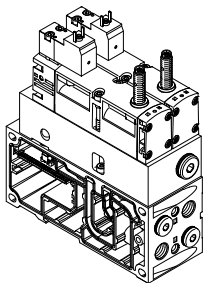

The control attributes of the control block enable Performance Level e to be achieved for the protective measures. The control block has been developed and manufactured in accordance with the basic and proven safety principles of EN ISO 13849-1 and EN ISO 13849-2.

The valves with integrated switching position sensing on manifold sub-base for valve terminal VTSA/VTSA-F need to be supplied with power regardless of the type of electrical actuation (individual, multi-pin plug or fieldbus/control block connection).

The requirements of EN ISO 13849-1 and EN ISO 13849-2 (e.g. CCF, DC) must be taken into consideration when installing and operating the component and when using it in higher categories (2 to 4).

When using this product in machines or systems subject to specific C standards, the requirements specified in these standards must be observed.

The electrical connection for the solenoid valves is established separately via a standardised square plug to EN 175301-803, type C.

The switching position sensing of the inductive PNP or NPN proximity switch is via a push-in connector size M8x1 to EN 61076-2-104.

The control block with safety function is designed for installation in machines and automation systems and must only be used in industrial applications (high-demand mode)!

The control block with safety function is suitable for use as a press safety valve to EN 962.

More information and technical data
→ Internet: User documentation

- - Note

The control block with safety function (VOFA) is also available as a decentralised individual connection variant with electrical and pneumatic individual connection.

For information see:
→ Internet: vofa

- - Note

The appropriate manifold sub-base VABV-S4- ..., which is required for integration into the valve terminal, is not part of the control block. It is automatically allocated by the configurator when the control block is selected.

Datasheet – Control block with safety function

Pneumatic/electrical links

Function

The safety function is achieved by pneumatically linking two ducts for two 5/2-way single solenoid valves within the control block: port 4 is only pressurised if both solenoid valves are switched to switching position 14.

Port 2 is always pressurised if at least one of the two solenoid valves is in the normal position. The valves are reset via a mechanical spring.

The switching operation of the solenoid valves can be sensed using the proximity switches on the solenoid valves (switching position sensing).

By connecting the control signal and the switching signal of the proximity switch, it is possible to check if the piston spool of the solenoid valve has reached or left the normal position (expectations).

The piston spools of the solenoid valves are designed so that pneumatic short circuits between ports 2 and 4 are prevented (positive overlap).

The two solenoid valves must be actuated via two separate ducts to achieve the required category 4 (Performance Level e, to EN ISO 13849-1).

Circuit symbol¹⁾

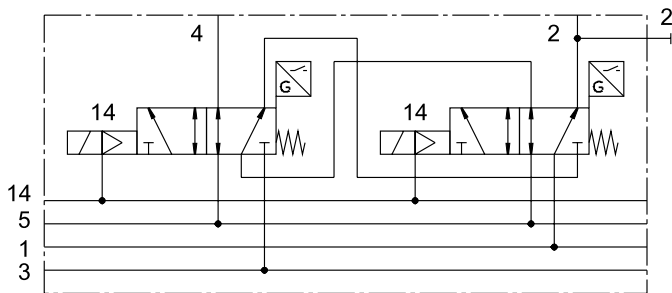

For the control block with safety function VOFA-B26-T52-... for the valve terminal, two 5/2-way solenoid valves of width 26 mm are pneumatically linked via two ducts, using an intermediate plate as vertical stacking element (output 2 is switched in parallel, output 4 is switched in series).

1) The circuit diagram represents a valve with a proximity switch with a N/O switching output signal.

This symbol applies to both N/O and N/C contacts, in accordance with ISO 1219-1. The switching element function of the sensors used here is designed as an N/C contact.

Safety characteristics

Conforms to standard	EN 13849-1
Safety function	Protection against manipulation, prevention of unexpected start-up Reversing a movement
Performance level (PL)	Protection against manipulation, prevention of unexpected start-up/up to category 4, Performance Level e Reversing a movement/up to category 4, Performance Level e
Note on forced checking procedure	Switching frequency at least once a week
Certificate-issuing authority	IFA 1001179
CE marking (see declaration of conformity)	To EU EMC Directive ¹⁾ To EU Machinery Directive
Max. positive test pulse with logic 0	[μs] 1000
Max. negative test pulse with logic 1	[μs] 800
Shock resistance	Shock test with severity level 2, to EN 60068-2-27
Vibration resistant	Transport application test with severity level 2, to EN 60068-2-6

1) For information about the area of use, see the EC declaration of conformity at: www.festo.com/catalogue/...d/Support/Downloads.

If the devices are subject to usage restrictions in residential, commercial or light-industrial environments, further measures for the reduction of the emitted interference may be necessary.

Datasheet – Control block with safety function

Peripherals overview

Electrical connection option for control block with safety function via PROFIsafe shut-off module CPX-FVDA-P2 (safety module)

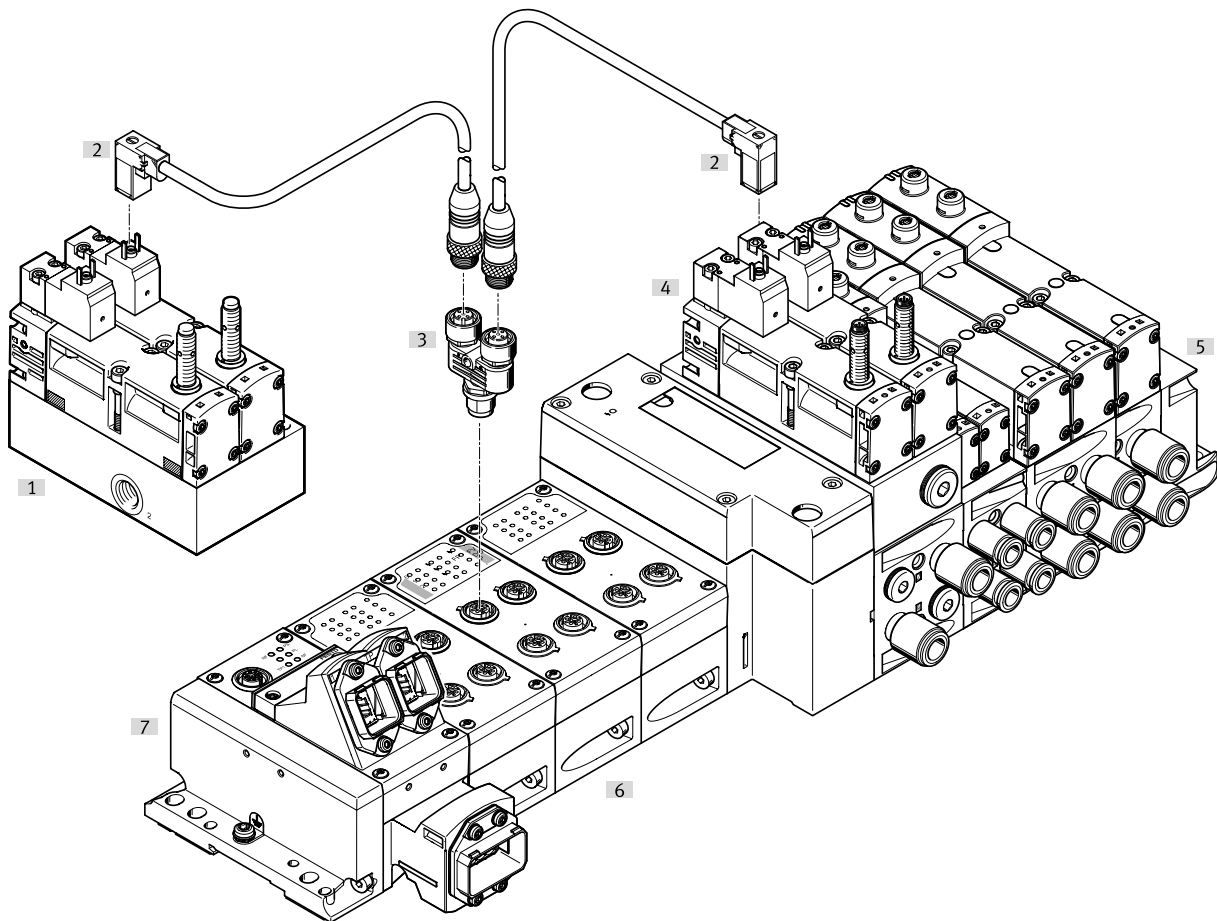

Peripherals overview		Description	→ Page/Internet
[1]	Control block with safety function	Away from the valve terminal as a decentralised individual connection variant	vofa
[2]	Connecting cable KMEB-...	For electrical connection of the control block with safety function via PROFIsafe shut-off module CPX-FVDA-P2 (safety module)	kmeb
[3]	Push-in T-connector NEDU-...	For simultaneously actuating two valves, e.g. control block with safety function	nedu
[4]	Control block with safety function	Integrated in the pneumatic section of the valve terminal VTSA/VTSA-F	-
[5]	Pneumatic section of the valve terminal VTSA/VTSA-F	Pneumatic components of the valve terminal VTSA/VTSA-F	-
[6]	CPX-FVDA-P2 (safety module)	PROFIsafe shut-off module integrated in the CPX terminal of the valve terminal VTSA/VTSA-F	cpx
[7]	CPX terminal of the valve terminal VTSA/VTSA-F	Electrical components of the valve terminal VTSA/VTSA-F	-

Datasheet – Control block with safety function

General technical data		
Design		Piston spool valve
Standard nominal flow rate	[l/min]	830
Reset method		Mechanical spring
Sealing principle		Soft
Exhaust air function		Can be throttled
Actuation type		Electrical
Overlap		Positive overlap
Type of control		Piloted
Flow direction		Not reversible
Exhaust air function		Can be throttled
Suitable for vacuum		–
Nominal width	[mm]	9
Pilot air supply		Via valve terminal
Type of mounting		Via through-hole, on manifold sub-base
Mounting position		Any
Manual override		–
Signal status indication, valve		With accessories
Pneumatic connections		
Supply	1	Via the manifold sub-base of the valve terminal
Exhausting	3/5	
Working ports	2/4	
Pilot air supply	14	
Pressure gauge		G1/4
Operating and environmental conditions		
Operating medium		Compressed air to ISO 8573-1:2010 [7:4:4]
Pilot medium		Compressed air to ISO 8573-1:2010 [7:4:4]
Notes on operating/ Pilot medium		Lubricated operation possible (in which case lubricated operation will always be required)
Operating pressure	[bar]	0 ... 10
	[MPa]	0 ... 1
Operating pressure for valve terminal with internal pilot air supply	[bar]	3 ... 10
	[MPa]	0.3 ... 1
Pilot pressure	[bar]	3 ... 10
	[MPa]	0.3 ... 1
Noise level LpA	[dB(A)]	85
Ambient temperature	[°C]	–5 ... +50
Temperature of medium	[°C]	–5 ... +50
CE marking (see declaration of conformity)		To EU EMC Directive ¹⁾
		To EU Machinery Directive

1) For information about the area of use, see the EC declaration of conformity at: [www.festo.com/catalogue/... d Support/Downloads](http://www.festo.com/catalogue/...d/Support/Downloads).

If the devices are subject to usage restrictions in residential, commercial or light-industrial environments, further measures for the reduction of the emitted interference may be necessary.

Datasheet – Control block with safety function

Electrical data – Control block			
Electrical connection	Plug to EN 175301-803, type C, without PE conductor		
Nominal operating voltage	[V DC]	24	
Permissible voltage fluctuations	[%]	-15/+10	
Surge resistance	[kV]	2.5	
Pollution degree	3		
Power consumption	[W]	1.8	
Max. magnetic disruption field	[mT]	60	
Switching position sensing	Normal position via sensor		
Duty cycle	[%]	100	
Degree of protection to EN 60529	IP65, NEMA 4 (for all types of signal transmission when mounted)		
Protection against direct and indirect contact	PELV Protection class to EN 60950/IEC 950		
Valve switching time	On	[ms]	22
	Off	[ms]	59
Valve sensor switching time ¹⁾	On	[ms]	60
	Off	[ms]	11

- 1) Valve sensor switching time off: period of time from the coil being energised to the sensor being switched off when using a PNP sensor.
Valve sensor switching time on: period of time from the coil being de-energised to 0-L edge at the sensor when using a PNP sensor.

Note

With a 100% duty cycle, the control block must be de-energised once per week.

Electrical data – Sensor (to EN -60947-5-2)		
Electrical connection	Cable, 3-core 1x M8 plug, 3-pin	
Cable length	[m]	2.5
Switching output	PNP or NPN	
Switching element function	N/C	
Signal status indication	Yellow LED	
Operating voltage range	[V DC]	10 ... 30
Residual ripple	[%]	±10
Sensor no-load current	[mA]	Max. 10
Maximum output current	[mA]	200
Voltage drop	[V]	Max. 2
Max. switching frequency	[Hz]	5000
Short circuit current rating	Pulsed	
Reverse polarity protection for sensor	For all electrical connections	
Measuring principle	Inductive	

Materials	
Sub-base/manifold sub-base	Wrought aluminium alloy
Valve	Die-cast aluminium, PA
Seals	FPM, NBR, HNBR
Screws	Galvanised steel
Sensor housing	High-alloy stainless steel
Sensor cable sheath	PUR
Note on materials	RoHS-compliant

Datasheet – Control block with safety function

Dimensions

Download CAD data → www.festo.com

Version for valve terminal VTSA/VTSA-F

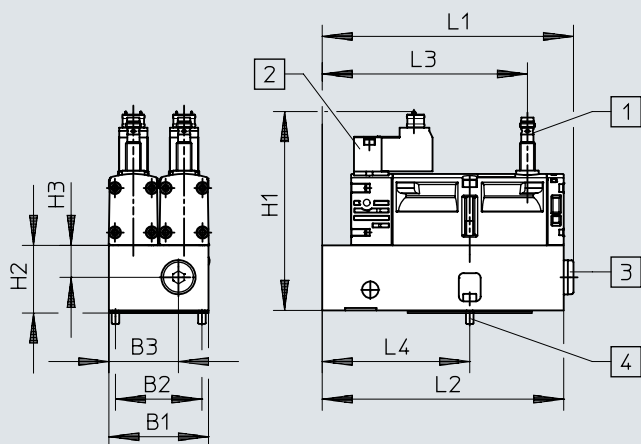

[1] Proximity switch PNP or NPN, size M8x1, plug connection to EN 61076-2-104

[2] Electrical connection to EN 175301-803, type C

[3] Pneumatic connection G1/4 sealed with blanking plug

[4] 2x screw with internal hex (width across flats 2.5), M4x12 (included in the scope of delivery)



Type	B1	B2	B3	H1	H2	H3	L1	L2	L3	L4
VOFA-B26-T52-M-1C1-APP	53	46	37	105.8	34.6	17	133.7	128.5	109.2	78.5
VOFA-B26-T52-M-1C1-ANP										

Ordering data

Code	Valve function	Switching output	Weight [g]	Part no.	Type
------	----------------	------------------	------------	----------	------

Control block, version for valve terminal VTSA/VTSA-F

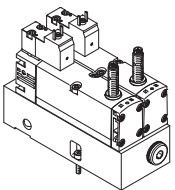
SP ²⁾		2x 5/2-way valve, single solenoid, mechanical spring return, with switching position sensing via inductive sensor and 3-pin sensor push-in connector M8, mounted on intermediate plate for pneumatic linking	PNP	1112	– ¹⁾	VOFA-B26-T52-M-1C1-APP
SN ²⁾		NPN	1112	– ¹⁾	VOFA-B26-T52-M-1C1-ANP	





1) The control block with safety function can only be ordered via the valve terminal configurator and therefore does not have a separate part number. The appropriate manifold sub-required base for the valve terminal VTSA/VTSA-F is automatically allocated to the control block by the configurator.

2) Code letter within the order code for a valve terminal configuration

Note

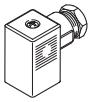
The sensors integrated in the valves must not be replaced by the customer. Incorrect assembly can result in malfunctions or damage to the valve. Please contact Festo in the event of a malfunction.

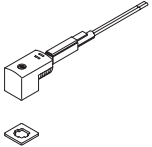
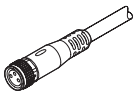
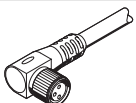
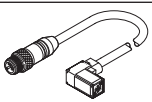



Accessories – Control block with safety function

Ordering data		Code	Description	Part no.	Type
Plug socket for the electrical connection of individual valves					
	–	• Angled socket, type C, 3-pin • PG7		151687	MSSD-EB
	–	• Angled socket, type C, 3-pin • M12x1		539712	MSSD-EB-M12
Illuminating seal for plug pattern to EN 175301-803				Datasheets → Internet: meb-ld	
	–	For plug socket MSSD		151717	MEB-LD-12-24DC
Connecting cable for electrical connection of individual valves					
	GG	• Angled socket, type C, 3-pin, with LED • Open end, 3-core	2.5 m	151688	KMEB-1-24-2.5-LED
	GH		5 m	151689	KMEB-1-24-5-LED
	GJ		10 m	193457	KMEB-1-24-10-LED
Connecting cable for the electrical connection of sensors for switching position sensing					
	GM	• Straight socket, M8x1, 3-pin • Open end, 3-core	2.5 m	8078223	NEBA-M8G3-U-2.5-N-LE3
	GN		5 m	8078224	NEBA-M8G3-U-5-N-LE3
	–	• Angled socket, rotatable, M8x1, 3-pin • Open end, 3-core	2.5 m	8001660	NEBU-M8R3-K-2.5-LE3
	–		5 m	8001661	NEBU-M8R3-K-5-LE3
Connecting cable for the electrical connection of PROFIsafe shut-off module CPX-FVDA-P2 to the control block					
	–	For the easy connection of one control block valve (power supply via PROFIsafe shut-off module CPX-FVDA-P2) • Angled socket, type C, 3-pin, with LED • Straight plug M12x1, 5-pin	0.5 m	177677	KMEB-2-24-M12-0.5-LED
Push-in T-connector for dual electrical connection of PROFIsafe shut-off module CPX-FVDA-P2 to the control block					
	–	For dual connection of two control block valves (power supply via PROFIsafe shut-off module CPX-FVDA-P2) • Straight plug, M12x1, 5-pin (A-coded) • 2x straight socket, M12x1, 5-pin (A-coded)		2839867	NEDU-L2R1-V10-M12G5-M12G5
Pneumatic connection accessories					
A selection of possible fittings, blanking plugs, silencers and other pneumatic accessories can be found in the chapter "Accessories" → page: 190 or on the website via the individual search terms: Internet → connection technology, silencer, blanking plug					

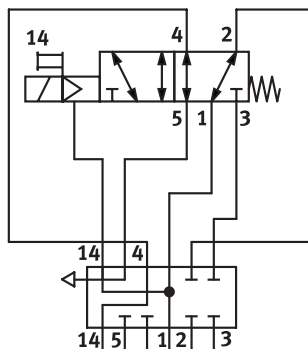
Datasheet – Pilot air switching valve

Function¹⁾



-  - Flow rate
150 l/min (18 mm)
450 l/min (26 mm)
-  - Valve width
18 mm
26 mm
-  - Voltage
24 V DC
-  - Operating pressure
-0.9 ... 10 bar

Description

The pilot air switching valve is essentially a combination of a 5/2-way solenoid valve with switching position sensing and the intermediate plate VABF-S4-...-S.. It enables the pilot air supply to be verifiably switched on and off (sensor

function) from duct 1 to 14 for the entire pressure zone or valve terminal. This valve is not a safety device in accordance with the Machinery Directive 2006/42/EC. When used in higher categories, the sensor signal from the

valve must be evaluated by the control system. This valve is suitable for use in safety-related parts of control systems to EN ISO 13849-1. This valve is designed for installation in machines and automation systems

and must only be used in industrial applications (high-demand mode).

Alternative switching position sensing with pressure switch

As an alternative to the sensing function in the solenoid valve, a pressure switch can be mounted (in place of the blanking plug) in the intermediate

plate VABF-S4-...-S. With this pressure switch, the switching on and off (sensing function) of the pilot air supply can be verified.

An ISO solenoid valve without a sensor can therefore be mounted on the intermediate plate to give the same function.

→ Internet: spba

Note

The pilot air switching valve can only be operated on the valve terminal VTSA/VTSA-F in combination with a right end plate for external pilot air type VABE-S6-1RZ-.... Port 14 on the right end plate must then be sealed.

Vertical stacking variant for valve terminal VTSA/VTSA-F, width 18 mm, 26 mm

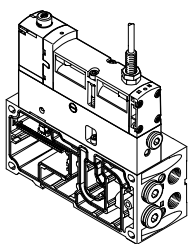

The valves with integrated switching position sensing in plug-in design for valve terminal VTSA/VTSA-F can be used regardless of the type of electrical actuation (individual, multi-pin plug or fieldbus/control block connection).

This module is supplied pre-assembled together with the valve terminal VTSA/VTSA-F. No other assembly steps are required before installation.

Switching position sensing is carried out using an inductive PNP proximity switch with cable and M12x1 push-in connector to EN 61076-2-104. Alternatively, combinations with a pressure switch in the intermediate plate and ISO solenoid valves are possible.

Note

All solenoid valves VSVA to ISO 15407-1 can be used.

→ Internet: vsva

1) The circuit diagram represents a valve with a proximity switch with a N/O switching output signal. This symbol applies to both N/O and N/C contacts, in accordance with ISO 1219-1. The switching element function of the sensors used here is designed as an N/C contact.

Datasheet – Pilot air switching valve

Function of pneumatic/electrical links

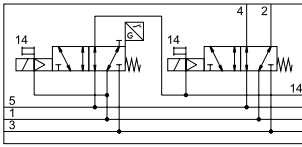

The function for switching off the pilot air is essentially achieved by combining the intermediate plate type VABF-S4-...-S with the 5/2-way single solenoid valve type VSVA-B-M52-MZD-...-1T1L-APX-0.5. The valve terminal is not supplied with any pilot air via the right end plate type VABE-S6-1 (ident. code XS, external pilot air). Port 14 on the end plate is sealed.

The pilot air for the valve is branched from duct 1 in the intermediate plate and redirected to the pilot air duct 14 of the valve terminal when the valve is in the switching position. Ports 2 and 4 of the manifold sub-base are sealed with blanking plugs. The switching operation of the solenoid valve can be sensed using the proximity switch in the solenoid valve (or pressure sensor in the intermediate plate VABF...).

By connecting the control signal and the switching signal of the proximity switch, it is possible to check if the piston spool of the solenoid valve has reached or left the normal position (expectations).

The piston spool of the solenoid valve is designed so that pneumatic short circuits between ports 2 and 4 are prevented (overlap).

Alternatively, combinations with a pressure switch in the intermediate plate and ISO solenoid valves are possible.

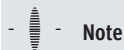

Note

A valve from the modular system VTSA/VTSA-F can be provided or configured to the right of the valve with switching position sensing on the intermediate plate of the pilot air switching valve.

Pilot air switching valve with integrated switching position sensing

The pilot air switching valve can be ordered as a combination of a 5/2-way solenoid valve with switching position sensing and the intermediate plate VABF-S4-...-S.

Alternative switching position sensing with pressure switch

As an alternative to the pilot air switching valve with integrated switching position sensing, it is possible to combine an ISO solenoid valve and a pressure switch in the intermediate plate.

To do this, various 5/2-way solenoid valves in combination with a pressure switch SPBA-... are available.

Safety characteristics

Conforms to standard	EN 13849-1/2
CE marking (see declaration of conformity)	To EU EMC Directive 1)
Shock resistance	Shock test with severity level 2, to EN 60068-2-27
Vibration resistant	Transport application test with severity level 2, to EN 60068-2-6

- 1) For information about the area of use, see the EC declaration of conformity at: www.festo.com/sp → Certificates.
If the devices are subject to usage restrictions in residential, commercial or light-industrial environments, further measures for the reduction of the emitted interference may be necessary.

Safety characteristics

Valve function 5/2-way, single solenoid	Test pulses	Test pulses	
		Max. positive test pulse with logic 0	Max. negative test pulse with 1 signal
VSVA-B-M52-MZ...-A1-1T1L- ...	[μs]	1200	1100
VSVA-B-M52-MZ...-A2-1T1L- ...	[μs]	1500	800
VSVA-B-M52-MZ-A1-1C1- ...	[μs]	1800	800

Datasheet – Pilot air switching valve

General technical data		
	Solenoid valve type VSVA-B-M52-MZD-A2-1T1L-APX-0.5 mounted on valve terminal VTSA/VTSA-F	Solenoid valve type VSVA-B-M52-MZD-A1-1T1L-APX-0.5 mounted on valve terminal VTSA/VTSA-F
Width	18 mm	26 mm
Design	Piston spool valve	
Sealing principle	Soft	
Overlap	Positive overlap	
Actuation type	Electrical	
Type of control	Piloted	
Type of mounting:		
Solenoid valve on intermediate plate	M3	M4
Intermediate plate on manifold sub-base	M3x12 (captive)	M4x12 (captive)
Mounting position	Any	
Pneumatic connections		
Supply	1	Via the manifold sub-base of the valve terminal
Exhausting	3/5	Via the manifold sub-base of the valve terminal
Working ports	2/4	Sealed with blanking plug type B-1/4
Pilot air supply	14	Via the manifold sub-base of the valve terminal
Pressure gauge/pressure switch	G1/8	

Switching times [ms]				
Width	18 mm		26 mm	
Valve type	5/2		5/2	
Identifier	MZD-A2		MZD-A1	MZ-A1
Valve switching time	On	12	20	21
	Off	38	54	41
Valve sensor switching time ¹⁾	On	32	60	60
	Off	9	11	11

- 1) Valve sensor switching time off: period of time from the coil being energised to the sensor being switched off when using a PNP sensor.
Valve sensor switching time on: period of time from the coil being de-energised to 0-L edge at the sensor when using a PNP sensor.

Protective circuit

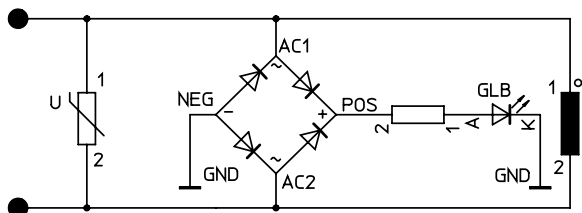

Each solenoid coil VSVA is protected with a spark arresting protective circuit as well as against polarity reversal.

Datasheet – Pilot air switching valve

Peripherals overview

Pilot air switching valve with switching position sensing

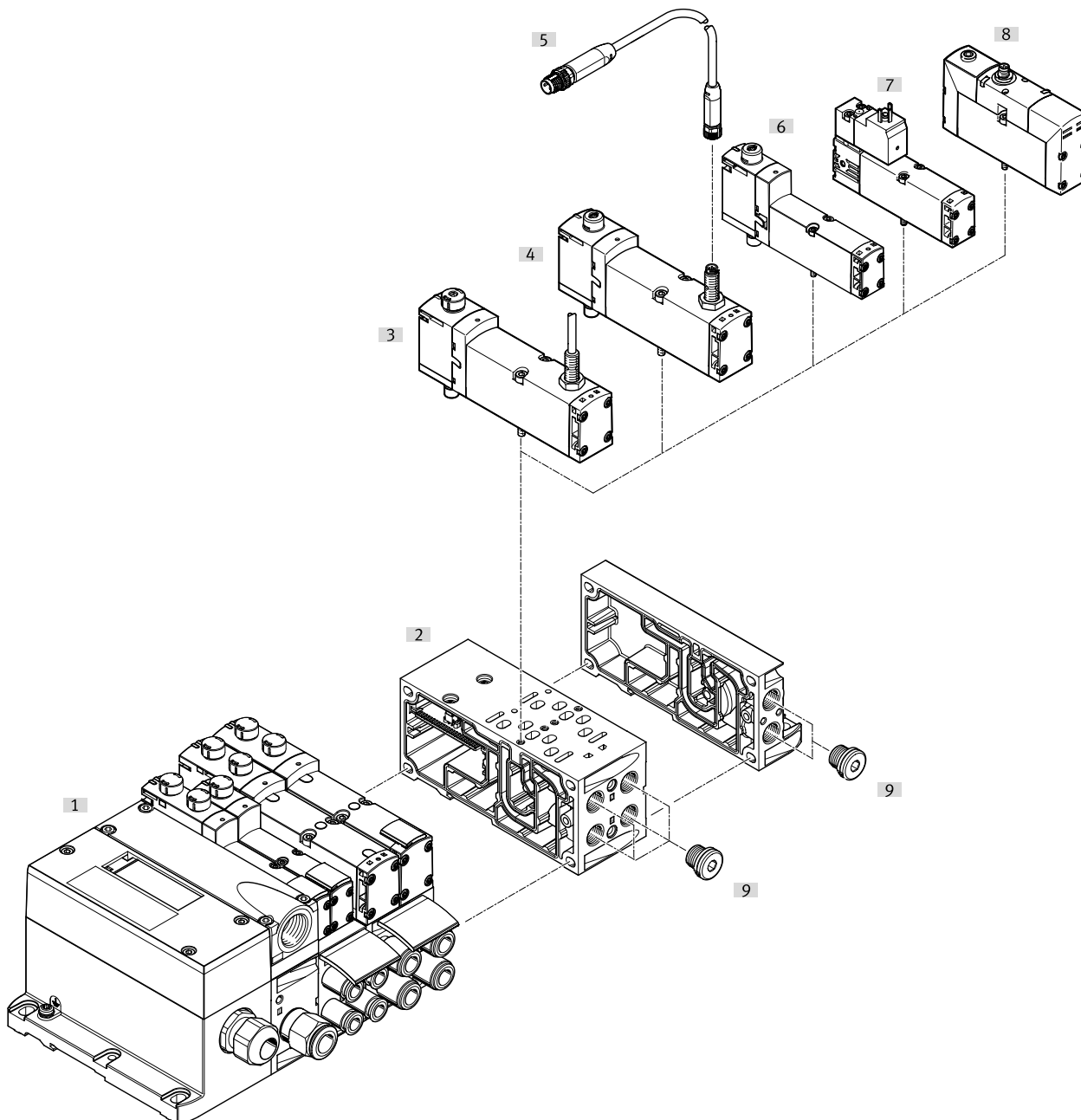
Peripherals overview – Pilot air switching valve

		Description	→ Page/Internet
[1]	Valve terminal VTSA/VTSA-F	Valve terminal with multi-pin plug interface	vtsa
[2]	Manifold sub-base VABF-...	Width 18 mm or 26 mm	129
[3]	Solenoid valve VSVA-B-M52-...	Width 18 mm or 26 mm, with sensor and integrated cable 0.5 m	162
[4]	Solenoid valve VSVA-B-M52-...	Width 18 mm or 26 mm, with sensor for external connecting cable	162
[5]	Connecting cables NEBA	For connecting to the sensor	163
[6]	Solenoid valve VSVA-B-M52-...	Width 18 mm or 26 mm 1)	162
[7]	Solenoid valve VSVA-B-M52-...	Width 18 mm or 26 mm, with plug to EN 175301, type C 1)	162
[8]	Solenoid valve VSVA-B-M52-...	Width 18 mm or 26 mm, with round plug 1)	vsva
[9]	Blanking plug	–	191

1) The switching position is sensed by pressure switches when the solenoid valves used have no integrated sensor.
The pressure switch is screwed into the intermediate plate in place of the blanking plug.

Datasheet – Pilot air switching valve

Electrical data – Pilot air switching valve		
Nominal operating voltage	[V DC]	24
Permissible voltage fluctuations	[%]	±10
Surge resistance	[kV]	2.5
Pollution degree		3
Power consumption	[W]	1.6 (M52-MZD), 1.8 (M52-MZ)
Max. magnetic disruption field	[mT]	60
Switching position sensing		Normal position via sensor
Duty cycle	[%]	100
Degree of protection		IP65, NEMA 4 (for all types of signal transmission when mounted)

Electrical data – Sensor					
Sensor designation	APP	ANP	APC	ANC	APX
Switching output	PNP	NPN	PNP	NPN	PNP
Sensor connection	1x M8 plug, 3-pin		With fixed cable and open end		With fixed cable and plug M12x1, 4-pin
Cable length	[m]	0.5 (with socket M8x1, plug M12x1)	2.5		0.5
Switching element function	N/C				
Signal status indication	Yellow LED (on the sensor)				
Operating voltage range	[V DC]	10 ... 30			
Residual ripple	[%]	±10			
Rated operating voltage	[V DC]	24			
Max. no-load supply current	[mA]	10			
Max. output current	[mA]	200			
Max. voltage drop	[V]	2			
Max. switching frequency	[Hz]	5000			
Short circuit current rating		Pulsed			
Reverse polarity protection		For all electrical connections			
Measuring principle		Inductive			
Switching position sensing		Valve normal position via sensor			

Datasheet – Pilot air switching valve

Operating and environmental conditions				
Valve		VSVA-B-M52-...-1T1L-...	VSVA-B-M52-...-1C1-...	Without sensor
Operating medium		Compressed air to ISO 8573-1:2010 [7:4:4]		
Notes on operating/ Pilot medium		Lubricated operation possible (in which case lubricated operation will always be required)		
Operating pressure	[bar]	-0.9 ... 10	-0.9 ... 16	-0.9 ... 10
	[MPa]	-0.09 ... 1	-0.09 ... 1	-0.09 ... 1
Noise level LpA	[dB(A)]	85	85	-
Ambient temperature	[°C]	-5 ... +50	-5 ... +50	-5 ... +50
Temperature of medium	[°C]	-5 ... +50	-5 ... +50	-
Note on materials		RoHs-compliant	RoHs-compliant	RoHs-compliant
KC marking		KC EMC	KC EMC	-
UKCA marking		To UK EMC regulations	To UK EMC regulations	-
Certification		C-Tick	C-Tick	-
		c UL us Recognized (OL)	-	c UL us Recognized (OL)

Materials	
Sub-base/manifold sub-base	Die-cast aluminium
Valve	Die-cast aluminium, PA
Seals	FPM, NBR
Screws	Galvanised steel
Sensor housing	High-alloy stainless steel
Sensor cable sheath	TPE-U(PUR)

Product weight		
Width	18 mm	26 mm

Solenoid valve		
VSVA-B-M52-MZD-A1-1T1L-APC	-	307 g
VSVA-B-M52-MZD-A1-1T1L-APP	-	264 g
VSVA-B-M52-MZ-A1-1C1-APC	-	332 g
VSVA-B-M52-MZ-A1-1C1-APP	-	289 g
VSVA-B-M52-MZD-A1-1T1L-ANC	-	307 g
VSVA-B-M52-MZD-A1-1T1L-ANP	-	264 g
VSVA-B-M52-MZ-A1-1C1-ANC	-	332 g
VSVA-B-M52-MZ-A1-1C1-ANP	-	289 g
VSVA-B-M52-MZD-A1-1T1L-APX-0.5	-	281 g
VSVA-B-M52-MZD-A2-1T1L-APX-0.5	157 g	-
VSVA-B-M52-MZD-A2-1T1L-APP	140 g	-
VSVA-B-M52-MZD-A2-1T1L-ANP	140 g	-
VSVA-B-M52-MZD-A1-1T1L	-	293 g
VSVA-B-M52-MZD-A2-1T1L	163 g	-

Ordering data – Pilot air switching valve

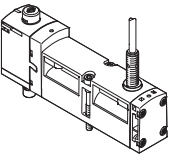
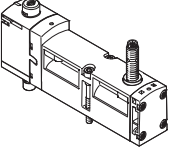
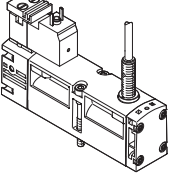
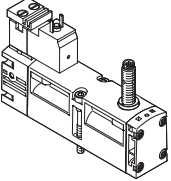
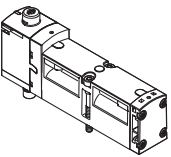
Ordering data		Code	Valve function		Part no.	Type
5/2-way solenoid valve, 24 V DC, plug-in design with proximity switch						
	SS	5/2-way valve, single solenoid, mechanical spring return, with 0.5 m connecting cable and 4-pin sensor push-in connector M12x1	PNP	18 mm	573201	VSVA-B-M52-MZD-A2-1T1L-APX-0.5
				26 mm	570850	VSVA-B-M52-MZD-A1-1T1L-APX-0.5
	–	5/2-way valve, single solenoid, mechanical spring return, with 2.5 m connecting cable	PNP	26 mm	560723	VSVA-B-M52-MZD-A1-1T1L-APC
			NPN	26 mm	560742	VSVA-B-M52-MZD-A1-1T1L-ANC
	SO	5/2-way valve, single solenoid, mechanical spring return, with 3-pin sensor push-in connector M8x1	PNP	18 mm	573202	VSVA-B-M52-MZD-A2-1T1L-APP
				26 mm	560724	VSVA-B-M52-MZD-A1-1T1L-APP
	SQ		NPN	18 mm	573203	VSVA-B-M52-MZD-A2-1T1L-ANP
				26 mm	560743	VSVA-B-M52-MZD-A1-1T1L-ANP
	–	5/2-way valve, single solenoid, mechanical spring return, with plug to EN 175301, type C, with 2.5 m connecting cable	PNP	26 mm	560725	VSVA-B-M52-MZ-A1-1C1-APC
			NPN	26 mm	560745	VSVA-B-M52-MZ-A1-1C1-ANP
	–	5/2-way valve, single solenoid, mechanical spring return, with plug to EN 175301, type C, with 3-pin sensor push-in connector M8x1	PNP	26 mm	560726	VSVA-B-M52-MZ-A1-1C1-APP
			NPN	26 mm	560744	VSVA-B-M52-MZ-A1-1C1-ANP
5/2-way solenoid valve, 24 V DC, plug-in design						
	–	5/2-way valve, single solenoid, mechanical spring return		26 mm	539159	VSVA-B-M52-MZD-A1-1T1L
				18 mm	539185	VSVA-B-M52-MZD-A2-1T1L

 - **Note**



Further solenoid valves with switching position sensing can be ordered as distinct types. These are preconfigured with the appropriate manual override cover caps.

→ Solenoid valve with switching position sensing, page 139



 - **Note**

The sensors integrated in the valves must not be replaced by the customer. Incorrect assembly can result in malfunctions or damage to the valve. Please contact Festo in the event of a malfunction.

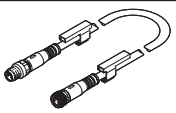
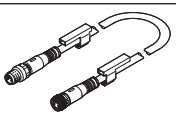
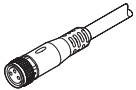
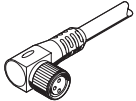
Ordering data – Pilot air switching valve

Ordering data					
	Code	Description	Part no.	Type	
Pressure switch for intermediate plate for pilot air switching valve					
	WL	Mechanical pressure switch (only in combination with intermediate plate ZO), with plug M12x1, 4-pin	8000033	SPBA-P2R-G18-W-M12-0.25X	
	WH	Electrical pressure switch, switching output 2xPNP (only in combination with intermediate plate ZO), with plug M12x1, 4-pin	8000210	SPBA-P2R-G18-2P-M12-0.25X	
Connecting cable for connection of pressure switches					
	GE	<ul style="list-style-type: none"> Straight socket, M12x1, 5-pin Straight plug, M12x1, 4-pin 	0.5 m	8000208	NEBU-M12G5-K-0.5-M12G4
Connecting cable for the electrical connection of sensors for switching position sensing					
	–	<ul style="list-style-type: none"> Straight socket, M8x1, 3-pin Straight plug, M12x1, 3-pin 	0.5 m	8000209	NEBU-M8G3-K-0.5-M12G3
	GM	<ul style="list-style-type: none"> Straight socket, M8x1, 3-pin Open end, 3-core 	2.5 m	8078223	NEBA-M8G3-U-2.5-N-LE3
	GN		5 m	8078224	NEBA-M8G3-U-5-N-LE3
	GO	<ul style="list-style-type: none"> Angled socket, M8x1, 3-pin Open end, 3-core 	2.5 m	8078230	NEBA-M8W3-U-2.5-N-LE3
	GP		5 m	8078231	NEBA-M8W3-U-5-N-LE3
	–		2.5 m	8001660	NEBU-M8R3-K-2.5-LE3
	–		5 m	8001661	NEBU-M8R3-K-5-LE3

Ordering data – Pilot air switching valve

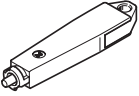
Ordering data					
	Code	Description		Part no.	Type
Covering					
	N	Cover cap for manual override, non-detenting	Pack of 10	541010	VAMC-S6-CH
	V	Cover cap for manual override, concealed	Pack of 10	541011	VAMC-S6-CS
	A	Cover cap, heavy duty, for manual override, non-detenting heavy duty, detenting via accessory (key) (The cover cap is provided for one-off mounting only)	Pack of 10	4105147	VAMC-B-S6-CTR
Accessories for manual override, heavy duty					
	–	Coded key (accessory) for actuating cover cap, heavy duty, for detenting position	Pack of 1	1662543	AHB-MEB-B
Pneumatic connection accessories					
A selection of possible fittings, blanking plugs, silencers and other pneumatic accessories can be found in the chapter "Accessories" → page: 190 or on the website via the individual search terms: Internet → connection technology, silencer, blanking plug					

 **Note**

There is a wide range of preconfigured solenoid valves with cover cap for manual override and correct valve type code available to order in the sections on solenoid valves.

Datasheet – Soft-start valve for VTSA/VTSA-F

Function
without sensor

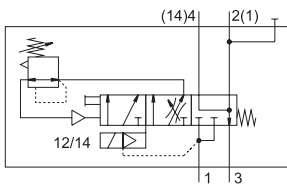

With sensor

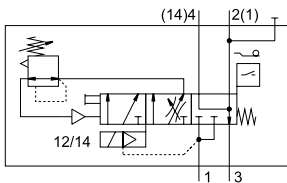

-  - Flow rate
Pressurisation:
3000 l/min
Exhausting: 3300 l/min

-  - Module width
43 mm

-  - Temperature range
-5 ... +50 °C

-  - Operating pressure
0.2 ... 1.2 MPa
2 ... 12 bar

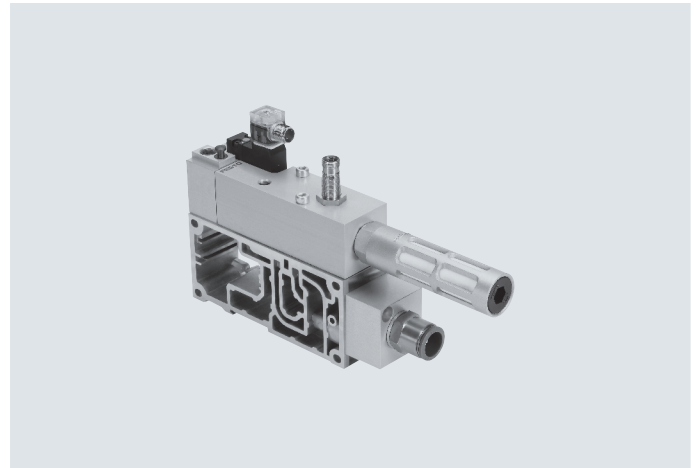

Description

Function

The purpose of the soft-start valve is to slowly and safely build up the supply pressure in duct 1 of the valve terminal or to quickly exhaust it via duct 1.

Switch-on takes place in two stages:

- First the working pressure for duct 1 gradually increases (the speed can be adjusted using a throttle screw).

- Once the working pressure in duct 1 reaches a previously set value, the soft-start valve switches to full operating pressure at duct 1 of the valve terminal.

The switching point for full operating pressure is set to 4 bar at the factory, but can be changed using an adjusting screw.

The full operating pressure is applied at duct 14 (pilot air) at all times. This pressure causes the valves on the valve terminal to immediately move to the required switching position, so an unspecified position is not possible.

Duct 1 of the valve terminal is exhausted via the soft-start valve's exhaust port only in the normal position, when the valve is not switched. The exhaust air can optionally be ducted with a fitting or using a silencer.

A detenting manual override with self-reset via an electrical control signal is available for maintenance and service purposes.

- - Note

When using "Protection against unexpected start-up":
Protection against unexpected activation of the manual override (MO) must be guaranteed in all operating modes.

Diagnostics

The piston position of the soft-start valve can be monitored by a sensor with integrated LED display. This sensor registers whether the valve has switched and thus whether the valve terminal is being supplied with working air.

Pressure sensing via a pressure gauge (optional) is also possible.

The soft-start valve can also be ordered with a sensor. A sensor cannot be retrofitted at a later date because of the calibration that is required.

Connecting cables with integrated LED display are provided for displaying the signal status.

Pilot air supply

The valve terminal can either be supplied with internal pilot air via the soft-start valve or with internal or external pilot air via the various end plate variants.

The pilot air supply for the valve terminal (internal/external) is determined by the seal between the manifold sub-base and the soft-start valve.

The scope of delivery of the soft-start valve includes both the seal for internal pilot air supply (with drilled hole) and the seal for external pilot air supply (no drilled hole).

The soft-start valve itself is always supplied with internal pilot air.

Datasheet – Soft-start valve for VTSA/VTSA-F

Creating pressure zones with a soft-start valve

The soft-start valve can be used for the pneumatic compressed air supply of the valve terminal or of a pressure zone. The soft-start valve can only be used as the sole compressed air supply component on valve terminals with one pressure zone or within a pressure zone.

If a soft-start valve in combination with a right end plate (code XP3) is chosen for a pressure zone, a supply plate with a blanking plug in duct 1 (code W) is required in this pressure zone.

When using a soft-start valve, a supply plate (with blanking plug in duct 1) is generally also required for this pressure zone to discharge the exhaust air (duct 3/5).

A supply plate is not required if the exhaust air (duct 3/5) in a pressure zone with a soft-start valve can be expelled via the right end plate.

Constraints

Compressed air supply	Exhaust air	Pilot air supply	Reverse operation
There must be no other elements supplying compressed air in the pressure zone in which the soft-start valve is being used.	Exhaust air cannot be expelled via the soft-start valve. If it is being used in a pressure zone with duct 3/5 separate, an exhaust plate is required.	If the soft-start valve is used for internal pilot air supply (duct 14), there must be no other pilot air supply within the valve terminal.	The soft-start valve is not approved for reverse operation.

Note

Setting options as well as drawings with descriptions of the components for the soft-start valve can be found in the user documentation. The adjusting screws are freely accessible once they are fitted.

Safety characteristics

Conforms to standard	ISO 5599-2
Note on forced checking procedure	Switching frequency min. once a month
Max. positive test pulse with logic 0 [µs]	2500 ¹⁾
Max. negative test pulse with logic 1 [µs]	1400 ¹⁾
Shock resistance	Shock test with severity level 2, to EN 60068-2-27
Vibration resistant	Transport application test with severity level 2, to EN 60068-2-6

1) Values apply only to types with direct voltage 24 V DC

General technical data

	VABF-S6-1-P5A4-N12-4-1	VABF-S6-1-P5A4-N12-4-1-P	VABF-S6-1-P5A4-N12-4-1-N
Design	Piston spool		
Actuation type	Electrical		
Overlap	–	–	Negative overlap
Sealing principle	Soft		
Type of mounting	On sub-base, ISO size 1 to ISO 5599-2		
Mounting position	Any		
Valve function	Soft-start function		
Manual override	Detenting, self-resetting via electrical control signal, normal position on top, → page 172		
Reset method	Mechanical spring		
Type of control	Piloted		
Pilot air supply	Internal, external		
Flow direction	Not reversible		
Switching position sensing	Switching position with sensor		

Standard nominal flow rate [l/min]

Pressurisation	3000
Exhausting	3300

Datasheet – Soft-start valve for VTSA/VTSA-F

Operating and environmental conditions		
Operating medium		Compressed air to ISO 8573-1:2010 [7:4:4]
Notes on operating/ pilot medium		Lubricated operation possible (in which case lubricated operation will always be required)
Operating pressure	[bar]	2 ... 12
	[MPa]	0.2 ... 1.2
Switchover pressure presetting	[bar]	4
	[MPa]	0.4
Ambient temperature	[°C]	-5 ... +50
Note on materials		RoHS-compliant

Valve switching times [ms]		
Valve switching time	On	17
	Off	50

Electrical data – Soft-start valve		
Electrical connection		Plug, type C to EN 175301-803, square design
Nominal operating voltage	[V]	24 DC
Operating voltage range	[V]	24 DC ±10%
Characteristic coil values		24 V DC: 2.5 W
Degree of protection to EN 60529		IP65, NEMA 4 (for all types of signal transmission when mounted)

Electrical data – Sensor			
Type		SIEN-M12B-PS-S-L	SIEN-M12B-NS-S-L
Electrical connection		Plug M12x1 to EN 60947-5-2, 4-pin	
Switching output		PNP	NPN
Switching element function		N/O	
Signal status indication		Yellow LED	
Operating voltage range	[V DC]	10 ... 30	
Residual ripple	[%]	±10	
Rated operating voltage	[V DC]	24	
Max. no-load current for sensor	[mA]	10	
Max. output current	[mA]	200	
Max. voltage drop	[V]	2	
Max. switching frequency	[Hz]	3000	
Short circuit current rating		Pulsed	
Reverse polarity protection for sensor		For all electrical connections	
Measuring principle		Inductive	
Switching position sensing		Switching position with sensor	

Materials – Soft-start valve		
	Soft-start valve	Manifold sub-base
Housing	Wrought aluminium alloy	Die-cast aluminium
Seals	NBR, HNBR	–
Screws	Galvanised steel	–

Datasheet – Soft-start valve for VTSA/VTSA-F

Example 1: Pressure zone with soft-start valve and pilot air supply

Internal, external pilot air supply

Requirements

- Compressed air supply via soft-start valve
- Right end plate1): blanking plug in duct 1

For internal pilot air supply:

- Seal (soft-start valve - manifold sub-base) with pilot air supply bore "open" and
- Right end plate: blanking plug in duct 14

For external pilot air supply:

- Seal (soft-start valve - manifold sub-base) with pilot air supply bore "closed" and
- Pilot air supply via duct 14 in the right end plate

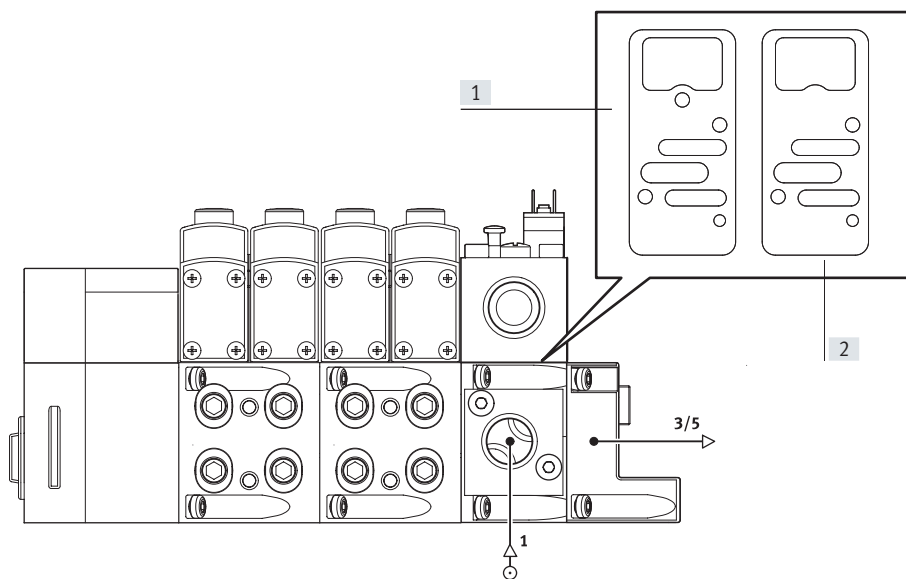

[1] Seal for internal pilot air supply

[2] Seal for external pilot air supply

1) A right end plate with pilot air selector cannot be used with this configuration, as it doesn't allow the exhaust air to be discharged

Example 2: Pressure zone with soft-start valve, supply plate and pilot air supply

Internal, external pilot air supply

Requirements

- Compressed air supply via soft-start valve
- Supply plate: blanking plug in duct 1
- Right end plate: blanking plug in duct 1, 3, 5 or
- Right end plate with pilot air selector

For internal pilot air supply:

- Seal (soft-start valve - manifold sub-base) with pilot air supply bore "open" and
- Right end plate: blanking plug in duct 14 or
- End plate with coding (position 2, internal pilot air supply)

For external pilot air supply:

- Seal (soft-start valve - manifold sub-base) with pilot air supply bore "closed" and
- Pilot air supply via duct 14 in the right end plate or
- End plate with coding (position 1, external pilot air supply)

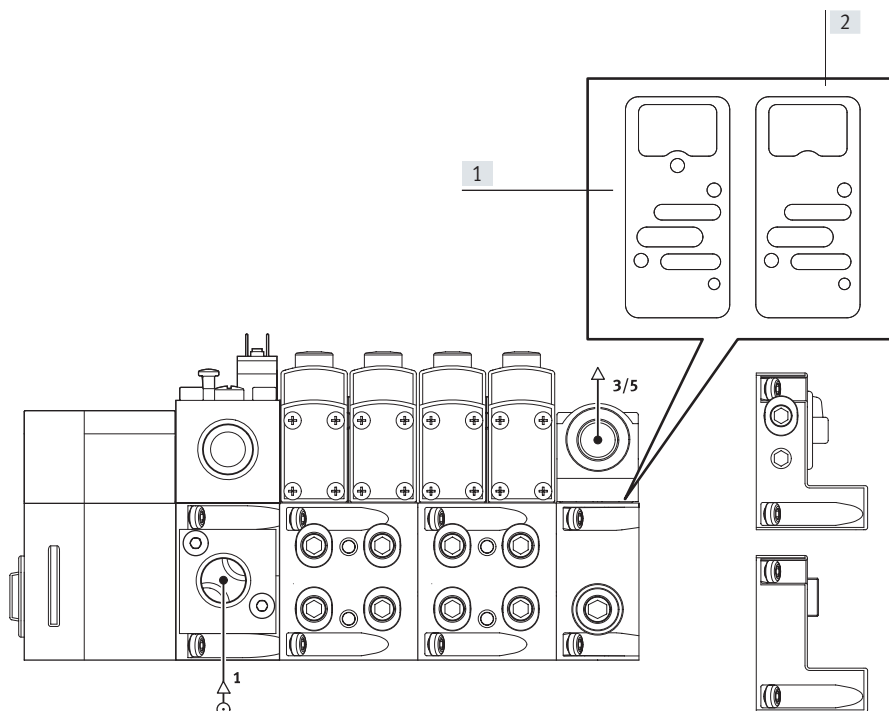

[1] Seal for internal pilot air supply

[2] Seal for external pilot air supply

Datasheet – Soft-start valve for VTSA/VTSA-F

Practical example 1: Valve terminal VTSA with CPX terminal (metal design) and soft-start valve

With internal pilot air (PP and XP2):

Selection no.: 539217

With external pilot air (PM and XP1):

Selection no.: 539217

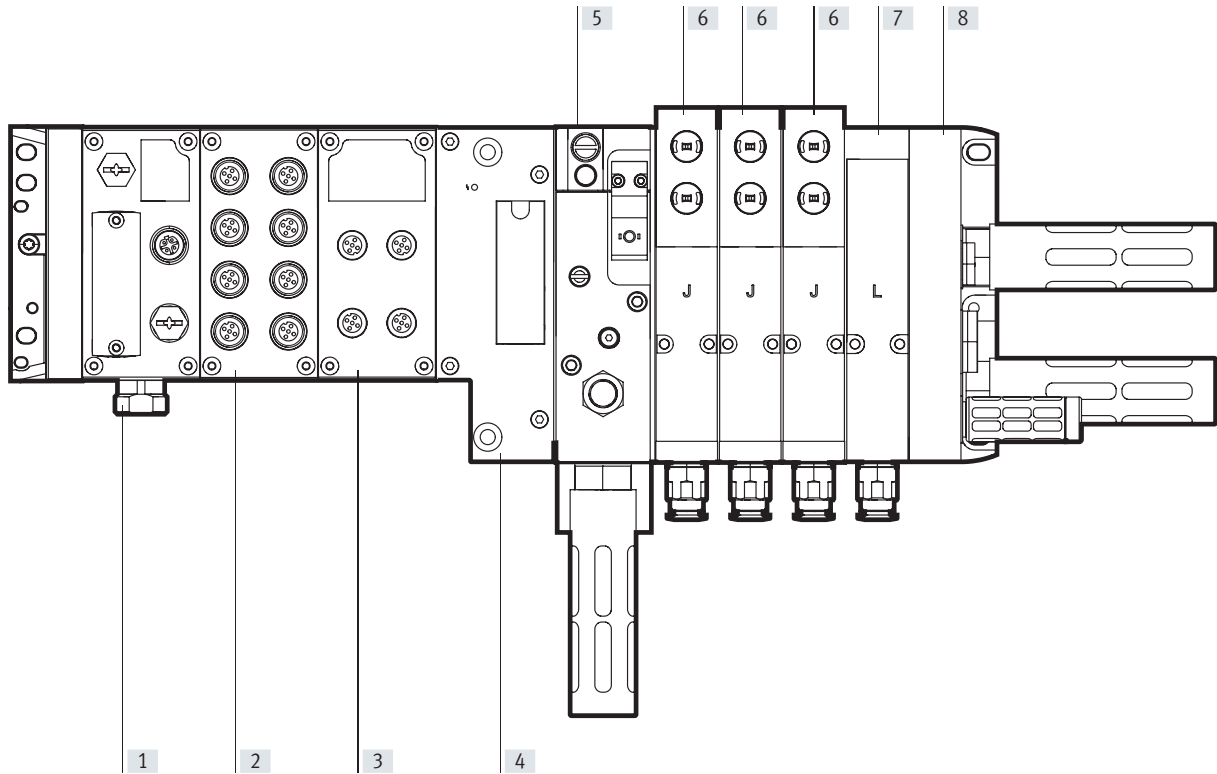

- | | | | |
|--|--|--|--|
| [1] Bus node for EtherNet/IP or Modbus TCP | [4] CPX pneumatic interface | [6] 5/2-way valve, double solenoid (J) | [8] Right end plate (XP2) with supply air/exhaust air, external pilot air supply, blanking plug in duct 1 and 14 |
| [2] Input module (16 digital inputs) | [5] Soft-start valve (PP – internal pilot air) | [7] Vacant position (L) | [8] Right end plate (XP1) with supply air/exhaust air, external pilot air supply, blanking plug in duct 1 |
| [3] Output module (8 digital outputs) | [5] Soft-start valve (PM – external pilot air) | | |

Selection with internal pilot air (PP and XP2):

Selection no. in the online catalogue: 539217

Electrical part: 51E-F36GCQPNMKBLX-S+GSBA

Pneumatic part: 44P-N-XP2-SMPP-BB-3JL+UGBP1

Selection with external pilot air (PM and XP1):

Selection no. in the online catalogue: 539217

Electrical part: 51E-F36GCQPNMKBLX-S+GSBA

Pneumatic part: 44P-N-XP1-SMPM-BB-3JL+UGBP1

Datasheet – Soft-start valve for VTSA/VTSA-F, width 43 mm

Practical example 2: Valve terminal VTSA with CPX terminal (metal design), soft-start valve and switching position sensing

With external pilot air (PM and XP2):

Selection no.: 539217

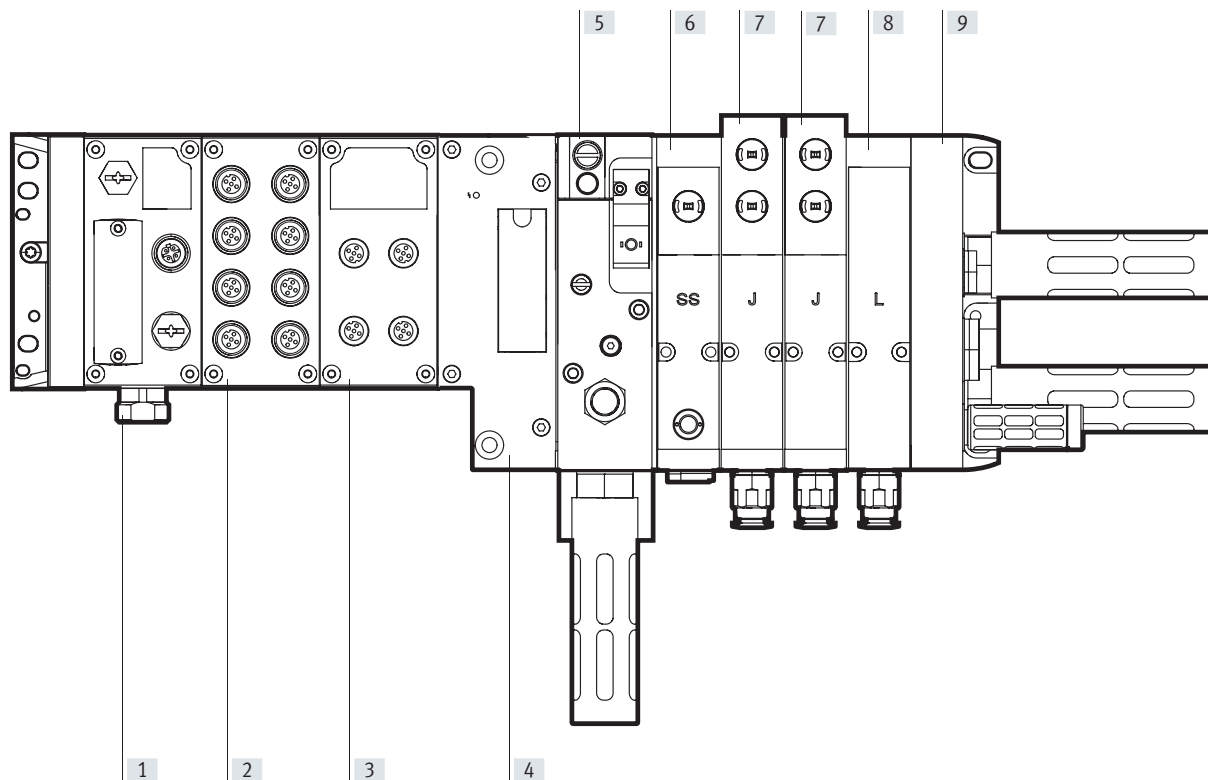

- | | | | |
|--|--|---|--|
| [1] Bus node for EtherNet/IP or Modbus TCP | [4] CPX pneumatic interface | [6] 5/2-way single solenoid valve, spring return, switching status indication with PNP sensor with 0.5 m connecting cable and push-in connector M12x1 (SS), and intermediate plate for switchable pilot air supply (ZO) | [7] 5/2-way double solenoid valve (J), width 26 mm |
| [2] Input module (16 digital inputs) | [5] Soft-start valve (PM – external pilot air) | | [8] Vacant position (L) |
| [3] Output module (8 digital outputs) | | | [9] Right end plate (XP2) with supply air/exhaust air, external pilot air supply, blanking plug in duct 1 and 14 |

Selection with external pilot air (PM and XP2), solenoid valve with switching position sensing (SS) and intermediate plate for switchable pilot air supply (ZO)

Selection no. in the online catalogue: 539217

Electrical part: 51E-F36GCQPNMKBLX-S+GSBA

Pneumatic part: 44P-N-XP2-SMPM-BB-SSZOJL+UGCGBP1

Datasheet – Soft-start valve for VTSA/VTSA-F

Practical example 3: Valve terminal VTSA with CPX terminal (metal design), switching position sensing, soft-start valve and 2 pressure zones

With external pilot air (PM and XP2)

Selection no.: 539217

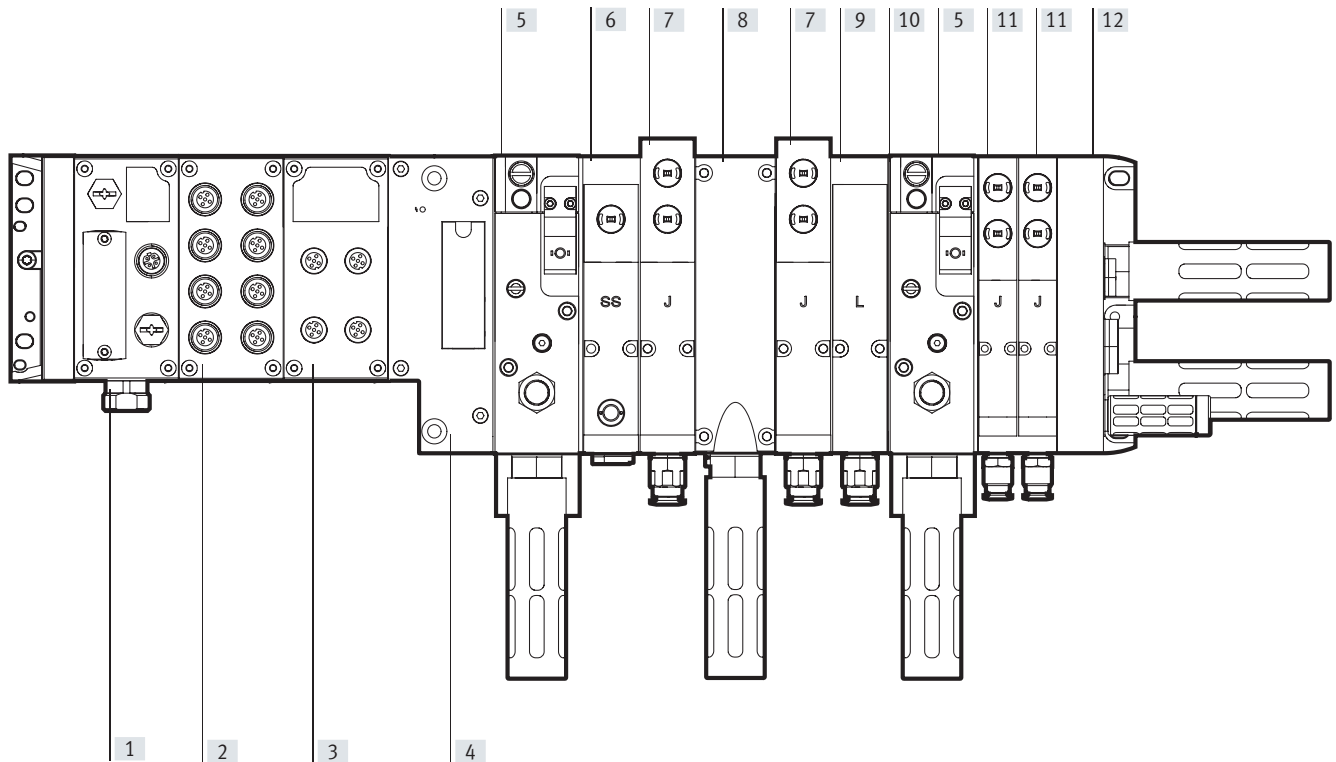

- | | | | |
|--|---|--|---|
| [1] Bus node for EtherNet/IP or Modbus TCP | [5] Soft-start valve for one pressure zone (PM – external pilot air) | [7] 5/2-way double solenoid valve (J), width 26 mm | [11] 5/2-way double solenoid valve (J), width 18 mm |
| [2] Input module (16 digital inputs) | [6] 5/2-way single solenoid valve, spring return, switching status indication with PNP sensor with 0.5 m connecting cable and push-in connector M12x1 (SS), and intermediate plate for switchable auxiliary pilot air supply (ZO) | [8] Exhaust plate (W) for ducts 3/5 | [12] Right end plate (XP2) with supply air/exhaust air, external pilot air supply, blanking plug in duct 1 and 14 |
| [3] Output module (8 digital outputs) | | [9] Vacant position (L) | |
| [4] CPX pneumatic interface | | [10] Duct separation (S) 1, 3, 5 | |

Selection with external pilot air (PM and XP2), solenoid valve with switching position sensing (SS) and intermediate plate for switchable pilot air supply and 2 pressure zones

Selection no. in the online catalogue: 539217

Electrical part: 51E-F36GCQPNMKBLX-S+GSBA

Pneumatic part: 44P-N-XP2-LSMPM-BWBSPMA-SSZOJLJJ+UGCGBP1

Electrical connection of pneumatic components

The solenoid valve with switching position sensing (SS), with sensor connection M12 is connected to the CPX input module using an appropriate connecting cable in order to link the sensor signal into the CPX system.

The soft-start valve (PM – with sensor PNP) is connected to the CPX input module using an appropriate connecting cable (GC) in order to integrate the sensor signal into the CPX system.

A connecting cable (GBP1) to/from the CPX output module is used to control the soft-start valve (PM). (Control signal)

Datasheet – Soft-start valve for VTSA/VTSA-F

Dimensions

Download CAD data → www.festo.com

Soft-start valve

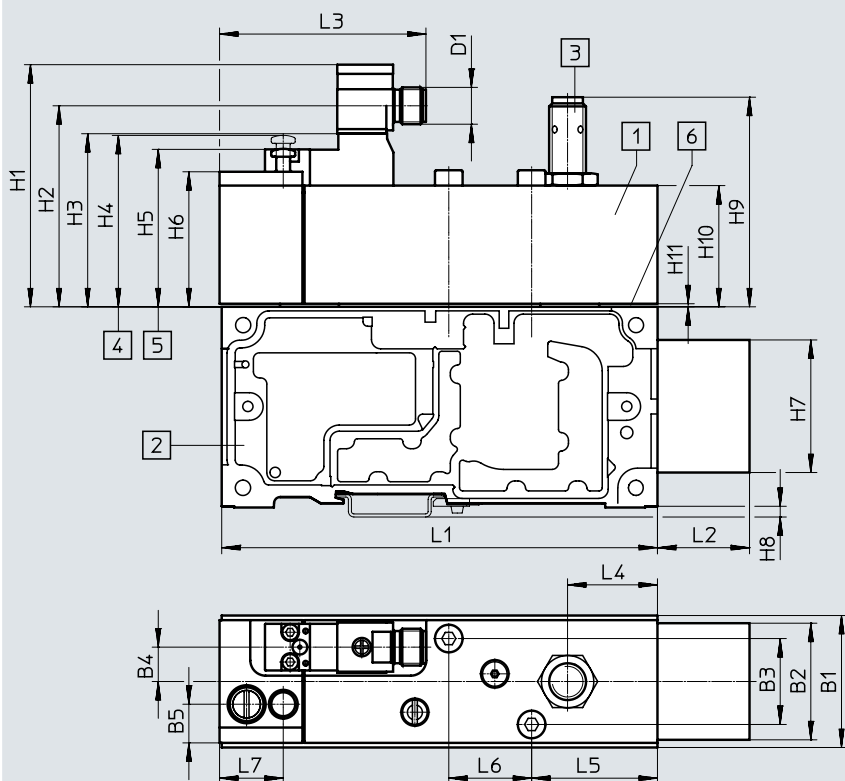

[1] Soft-start valve, (port pattern to ISO 5599-2)

[2] Manifold sub-base with connecting adapter (ducts 2 and 4), pneumatic connection G1/2

[3] Soft-start valve optionally with sensor or protective cap
[4] Manual override, normal position (unactuated)

[5] Manual override, switching position (actuated)
[6] Seal for internal or external pilot air supply of the valve terminal

Type	B1	B2	B3	B4	B5	D1	L1	L2	L3	L4	L5	L6	L7
VABF-S6-1-P5A4-G12-4-...	43	36.5	28	11.2	12.6	M12x1	142	30	67.3	29.3	41	27	20.8

Type	H1	H2	H3	H4	H5	H6	H7	H8	H9	H10	H11
VABF-S6-1-P5A4-G12-4-...	78.9	65.5	56.4	55.9	51.5	44	41.2	3.5	68.3	39.5	1

Seal 1) between soft-start valve and manifold sub-base

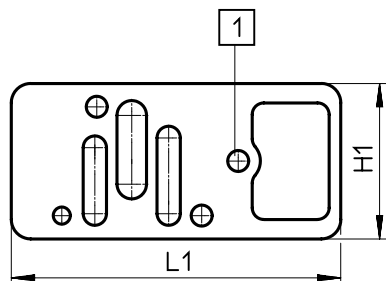

[1] With drilled hole, internal pilot air supply

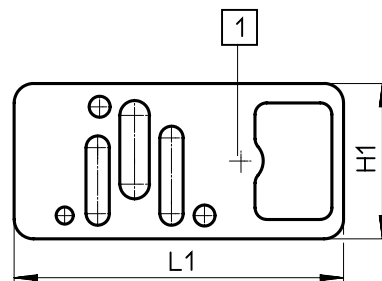







[1] Without drilled hole, external pilot air supply

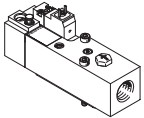

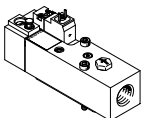

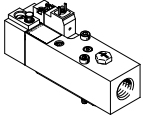

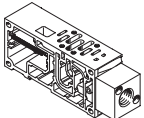
Type	H1	L1
VABD-S6-...	40	84.8

1) Seals are included with the soft-start valve

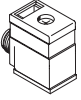
Datasheet – Soft-start valve for VTSA/VTSA-F

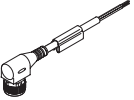
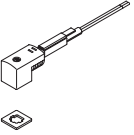
Ordering data					
	Terminal code	Description	Weight [g]	Part no.	Type
Soft-start valve					
	–	Without sensor output (with seals for internal and external pilot air)	590	558231	VABF-S6-1-P5A4-N12-4-1
	PN	Seal for external pilot air (without drilled hole)			
	PQ	Seal for internal pilot air (with drilled hole)			
	–	With sensor output PNP (with seals for internal and external pilot air)	605	558232	VABF-S6-1-P5A4-N12-4-1-P
	PM	Seal for external pilot air (without drilled hole)			
	PP	Seal for internal pilot air (with drilled hole)			
	–	With sensor output NPN (with seals for internal and external pilot air)	605	558234	VABF-S6-1-P5A4-N12-4-1-N
	PK	Seal for external pilot air (without drilled hole)			
	PO	Seal for internal pilot air (with drilled hole)			
Manifold sub-base					
	–	Suitable for a soft-start valve (ports for ducts 2 and 4 combined)	570	556988	VABV-S6-1Q-N12

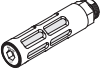

Accessories – Soft-start valve for VTSA/VTSA-F

Ordering data					
Designation	Code	Description	Part no.	Type	
Cover cap					
	–	M12, for sealing the sensor opening	Pack of 10	165592	ISK-M12
Electrical connection for soft-start valve					
	P1	<ul style="list-style-type: none"> Angled socket, type C, 2-pin, with LED Straight plug M12x1, 2-pin 		188024	MSSD-EB-M12-MONO
	GB	<ul style="list-style-type: none"> Straight socket, M12x1, 5-pin Open end, 4-core 	5 m	8078240	NEBA-M12G5-U-5-N-LE4
	–	<ul style="list-style-type: none"> Angled socket, M12x1, 5-pin Open end, 4-core 	5 m	8078249	NEBA-M12W5-U-5-N-LE4
	GG	<ul style="list-style-type: none"> Angled socket, type C, 3-pin, with LED 	2.5 m	151688	KMEB-1-24-2.5-LED
	GH	<ul style="list-style-type: none"> Open end, 3-core 	5 m	151689	KMEB-1-24-5-LED
	GJ		10 m	193457	KMEB-1-24-10-LED
	GK	<ul style="list-style-type: none"> Angled socket, type C, 3-pin 	2.5 m	151690	KMEB-1-230AC-2.5
	GL	<ul style="list-style-type: none"> Open end, 3-core 	5 m	151691	KMEB-1-230AC-5
Connecting cable for electrical connection of the proximity switch					
	–	<ul style="list-style-type: none"> Straight socket, M12x1, 5-pin Open end, 4-core 	5 m	8078240	NEBA-M12G5-U-5-N-LE4
	GC	<ul style="list-style-type: none"> Angled socket, M12x1, 5-pin Open end, 4-core 	5 m	8078249	NEBA-M12W5-U-5-N-LE4
Silencer					
	U	Standard version (pack of 1)	1/2 NPT	12741	U-1/2-B-NPT
	A	Sintered design (pack of 10)	1/2 NPT	1206992	AMTE-M-LH-N12
Pneumatic connection accessories					
A selection of possible fittings, blanking plugs, silencers and other pneumatic accessories can be found in the chapter "Accessories" → page: 190					

Datasheet – Vacuum block for VTSA/VTSA-F

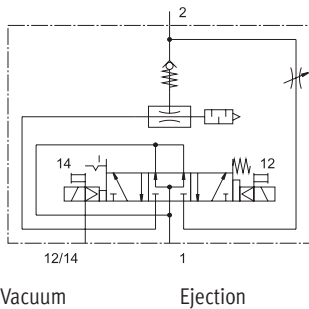
Function



-  - Vacuum block width
53 mm
-  - Voltage
24 V DC
-  - Operating pressure
0.4 ... 0.8 MPa
4 ... 8 bar

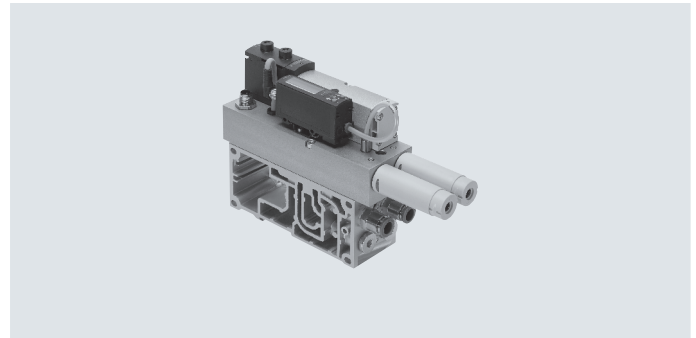

Description

The vacuum block can be integrated into the existing valve terminal VTSA/VTSA-F. To do this, the vacuum block is screwed to a manifold sub-base for 2 valve positions, width 26 mm.

The vacuum block is used in conjunction with a suction gripper to pick up, hold and place components. The suction gripper uses vacuum for picking up and holding.

Once the component has been positioned, it is released by an ejector pulse. This ejector pulse is created by pressurising the vacuum system so that the vacuum briefly collapses. The ejector pulse can be set.

Note

The vacuum block can be operated in combination with the vertical stacking for pilot air switch-off on the valve terminal VTSA/VTSA-F.

Function

The vacuum block VABF-S4-1-V2B1... is used to generate a vacuum. The generated vacuum and a suction gripper produce a force which is used to grip and transport a workpiece. The supply of compressed air for vacuum generation is controlled by a solenoid valve.

The vacuum is generated by actuating the solenoid coil 12. The setpoint value set at duct B for the generated vacuum is monitored via a vacuum sensor (with switching output). Vacuum generation reverts to a self-latching phase after reaching the setpoint value. The vacuum block controls the vacuum generation process independently within the range of the set switching points (air saving function).

The integrated solenoid valve is used to generate an ejector pulse by activating coil 14. The workpiece is thus safely released from the suction cup with connector and the vacuum is rapidly reduced. The length of the ejector pulse can be influenced by the duration of the electrical pulse. The strength of the ejector pulse is influenced by the adjustable flow control.

Note

If the electrical or pneumatic supply fails while the valve is in the "generate vacuum" or "air saving" state, the valve moves to the "generate vacuum" position.

Operating mode of the air saving function (LS)

If the desired threshold value (1) (turn off suction) is reached for the vacuum, vacuum generation is automatically switched off.

Check valves prevent the reduction of the vacuum. However, leakages (e.g. due to rough workpiece surfaces) will slowly reduce the vacuum.

If the vacuum drops below the set threshold value (turn on suction), vacuum generation is switched on automatically.

Vacuum is generated until the set threshold value (turn off suction) is reached again.

Threshold value to turn off suction (air saving function) (1):

The vacuum generator is switched off simultaneously when the output Out A is set.

The preset value is -700 mbar.

Threshold value to turn on suction (2):

The threshold value (2) should always be above the switching point of duct B (3) "vacuum sensing".

The gap between (2) and (3) should be at least 50 mbar.

Note

Setting options and further instructions are described in the operating instructions and/or documentation VABF-S4-1-V2B1...

→ Internet

Datasheet – Vacuum block for VTSA/VTSA-F

General technical data		
Valve function		5/3-way, pressurised
Design		Non-modular
Mounting position		Any
Nominal width of Laval nozzle (vacuum generation)	[mm]	2.0
Ejector characteristics		High vacuum, standard
Integrated functions		<ul style="list-style-type: none"> • Ejector pulse valve, electric • Flow restrictor • On/off valve, electric • Air-saving circuit, electric • Check valve • Open silencer • Vacuum switch
Silencer design		Open
Measured variable		Relative pressure
Measuring principle		Piezoresistive
Switching function		Threshold-comparator
Short circuit current rating		Yes
Reverse polarity protection		For all electrical connections
Inductive protective circuit		Adapted to MZ, MY, ME coils
Switching element function		N/O
Threshold-value setting range	[bar]	–0.999 ... 0 (recommended operating range: –0.95 ... –0.05)
	[MPa]	–0.0999 ... 0 (recommended operating range: –0.095 ... –0.005)
Hysteresis setting range	[bar]	–0.9 ... 0
	[MPa]	–0.09 ... 0
Power supply, vacuum block		Via own plug M12
Pneumatic supply for vacuum block		Via valve terminal VTSA/VTSA-F
Ejector pulse		Strength adjustable via flow control screw
Actuation type		Electrically actuated
• Solenoid valve		
• Vacuum block		Vacuum generation via Venturi nozzle
Type of actuation for solenoid valve		Piloted
Flow direction		Not reversible
Exhaust air function		Can be throttled (duct 3 and 5)
Type of mounting		Via through-hole, screwed onto manifold sub-base, width 26 mm
Manual override		Detenting, non-detenting, concealed
• For vacuum generation		Yes, solenoid coil 12 (holding)
• For ejector pulse		Yes, solenoid coil 14 (spring return), (only effective when power supply is switched off)
Signal status indication, valve		LED
Pneumatic connections		
Supply	1, 3	Via the manifold sub-base of the valve terminal, width 26 mm
Exhausting	3/5	Via the modular silencer for vacuum block
Working port (vacuum port)	2	Via the manifold sub-base of the valve terminal (QS push-in fitting – vacuum), G1/4
Connection	4	Via the manifold sub-base of the valve terminal (sealed with blanking plug type B-1/4)

Datasheet – Vacuum block

Technical data for pressure switch of vacuum block (delivery status)		
Duct A: air saving function		
Switching behaviour		Threshold-comparator
Switching point	[mbar]	-700
	[MPa]	-0.07
Hysteresis	[mbar]	200
	[MPa]	0.02
Switching characteristic		NO (normally open contact)
Duct B: vacuum sensing		
Switching behaviour		Threshold-comparator
Switching point	[mbar]	-400
	[MPa]	-0.04
Hysteresis	[mbar]	5
	[MPa]	0.0005
Switching characteristic		NO (normally open contact)

**Note**

Setting options for duct A and duct B and further instructions are described in the operating manual and/or documentation VABF-S4-1-V2B1....

Electrical data		
Electrical connection		4-pin plug to ISO 15407-2 (vacuum block supplied with power separately, not via valve terminal)
Nominal operating voltage	[V DC]	24
Operating voltage range	[V DC]	21.6 ... 26.4
Duty cycle	[%]	100
Maximum output current	[mA]	50
Voltage drop	[V]	≤1.5
No-load current	[mA]	50 ... 150 (dependent on the switching status of the solenoid coils)
Characteristic coil value	[V DC]	24
Power consumption (Characteristic coil values)	[W]	1.3
Overload protection		Available
Accuracy (full scale)	[% FS]	±3
Degree of protection to EN 60529		IP65, NEMA 4 (for all types of signal transmission when mounted)

Electrical connection ¹⁾			
	Plug M12x1, 4-pin to EN 61076-2-101	Pin1 + 24 V DC (brown (BN)) Pin2 Out B (white (WH)) Pin3 0 V DC (blue (BU)) Pin4 Out A (black (BK))	Supply voltage Switching output B (duct B) 0 V DC Switching output A (duct A)

1) Max. permissible signal cable length: 5 m

Datasheet – Vacuum block

Operating and environmental conditions

Operating medium	Compressed air to ISO 8573-1:2010 [7:4:4]	
Notes on the operating medium	Unlubricated operation	
Operating pressure	[bar]	4 ... 8
	[MPa]	0.4 ... 0.8
Nominal operating pressure	[bar]	6
	[MPa]	0.6
Pressure measuring range	[bar]	-1 ... 0
	[MPa]	-0.1 ... 0
Negative pressure	[bar]	Up to approx. 0.9 (as a function of operating pressure)
	[MPa]	Up to approx. 0.09 (as a function of operating pressure)
Ambient temperature	[°C]	0 ... 50
Temperature of medium	[°C]	0 ... 50
Noise level LpA (at nominal operating pressure)	[dB(A)]	78

Materials

Housing, jet nozzle	Wrought aluminium alloy
Screws	Galvanised steel
Seals	NBR
Plug housing	Nickel-plated die-cast zinc
Plug contacts	Gold-plated brass
Inspection window on pressure sensor	PA
Pressure sensor keypad	TPE-U
Note on materials	RoHS-compliant

Pressure ratios, air consumption and volumetric flow rate

Vacuum as a function of operating pressure

Air consumption as a function of operating pressure

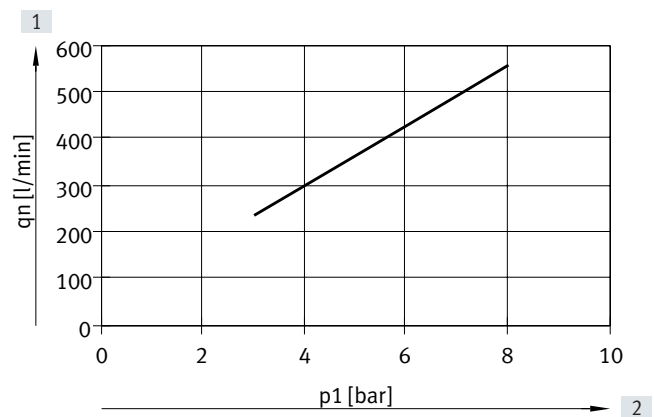
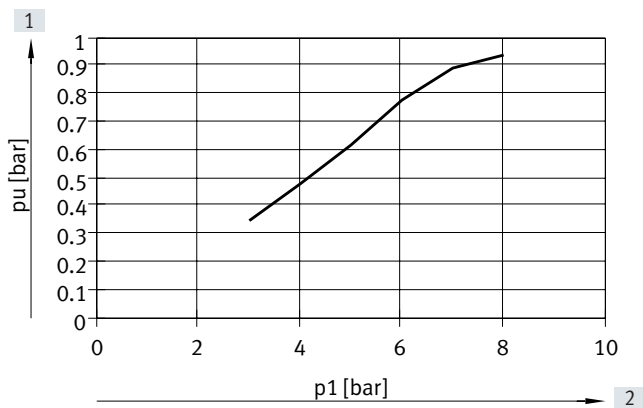

[1] Vacuum

[2] Operating pressure

[1] Air consumption

[2] Operating pressure

Datasheet – Vacuum block

Dimensions

Download CAD data → www.festo.com

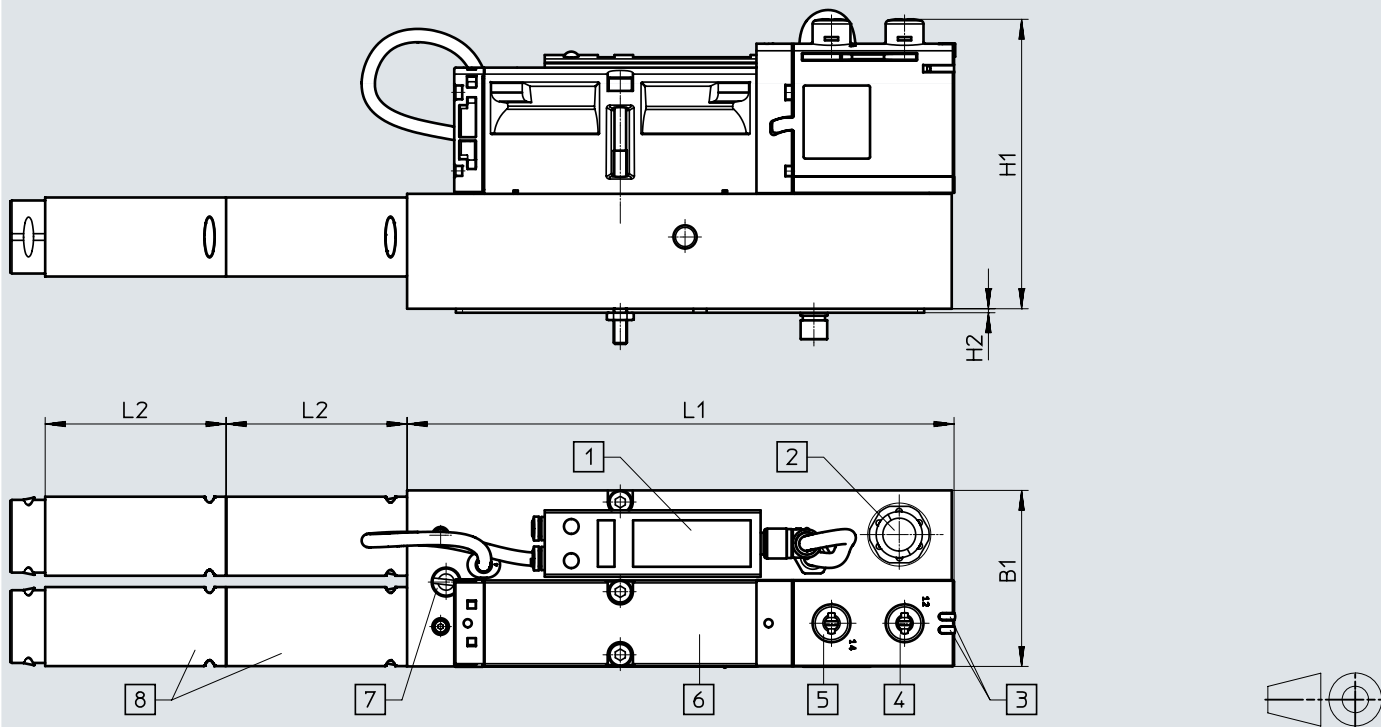

- [1] Pressure sensor with LCD display and operating buttons
- [2] Plug for electrical connection and vacuum sensing (M12, 4-pin)
- [3] LED signal status indication, solenoid valve
- [4] Manual override for vacuum generation
- [5] Manual override for ejector pulse (only effective when the power supply is switched off)
- [6] Solenoid valve
- [7] Flow control screw for adjusting the strength of the ejector pulse
- [8] Modular silencer

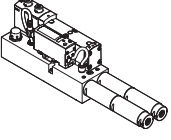
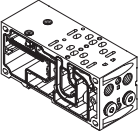
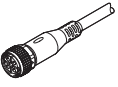
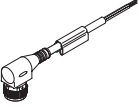

Type	B1	H1	H2	L1	L2
VABFS4-1-V2B1-CVH-20	53	87.1	1.2	164.7	54.2

Datasheet – Vacuum block

Ordering data				
	Code	Description	Part no.	Type
Vacuum block				
	VB	Vacuum block for valve terminal VTSA/VTSA-F with air-saving function and adjustable ejector pulse	1120 g	571425 VABF-S4-1-V2B1-C-VH-20
Manifold sub-base				
	L ²⁾	For vacuum block 2 valve positions, 4 addresses, with 2 blanking plugs in port 4	26 mm	– ¹⁾ VABV-S4-...
	LK ²⁾	For vacuum block 2 valve positions, 4 addresses, with 2 blanking plugs in port 4, with small QS fitting	26 mm	– ¹⁾ VABV-S4-...
Connecting cable				
	–	<ul style="list-style-type: none"> • Straight socket, M12x1, 5-pin • Open end, 4-core 	2.5 m	8078239 NEBA-M12G5-U-2.5-N-LE4
			5 m	8078240 NEBA-M12G5-U-5-N-LE4
	GC	<ul style="list-style-type: none"> • Angled socket, M12x1, 5-pin • Open end, 4-core 	5 m	8078249 NEBA-M12W5-U-5-N-LE4
Pneumatic connection accessories				
<p>A selection of possible fittings, blanking plugs, silencers and other pneumatic accessories can be found in the chapter "Accessories" → page: 190 or on the website via the individual search terms:</p> <p>Internet → connection technology, silencer, blanking plug</p>				

1) The manifold sub-base for use with the vacuum block can only be ordered via the valve terminal configurator and therefore doesn't have a separate part number.
 2) Code letter within the order code for a valve terminal configuration

Datasheet – Valves on individual sub-base

-  Valve width
to ISO 15407-2
- 18 mm
 - 26 mm
- to ISO 5599-2
- 42 mm (ISO 1)
 - 52 mm (ISO 2)
-  Flow rate
- Width 18 mm: up to 600 l/min
- Width 26 mm: up to 1200 l/min
- Width 42 mm: up to 1500 l/min
- Width 52 mm
up to 3400 l/min
-  Voltage
- 24 V DC
110 V AC

General technical data				
Design	Piston spool valve			
Sealing principle	Soft			
Actuation type	Electrical			
Type of control	Piloted			
Exhaust function, can be throttled	Via individual sub-base			
Lubrication	Lifetime lubrication			
Type of mounting	Screwed onto sub-base Screwed via through-hole			
• Valve				
• Individual sub-base				
Mounting position	Any			
Manual override	Detenting, non-detenting, concealed			
Pneumatic connections – NPT thread				
Width	18 mm	26 mm	42 mm	52 mm
Pneumatic connection	Via E-box			
Supply port	1	1/8 NPT	1/4 NPT	3/8 NPT
Exhaust port	3/5	1/8 NPT	1/4 NPT	3/8 NPT
Working ports	2/4	1/8 NPT	1/4 NPT	3/8 NPT
External pilot air supply port	14	10-32UNF-2B	1/8 NPT	1/8 NPT
Pilot exhaust air port	12	10-32UNF-2B	1/8 NPT	1/8 NPT

Operating and environmental conditions	
Operating medium	Compressed air to ISO 8573-1:2010 [7:4:4]
Notes on operating/ Pilot medium	Lubricated operation possible (in which case lubricated operation will always be required)
Operating pressure	[bar] -0.9 ... +10 [MPa] -0.09 ... +1
Ambient temperature	[°C] -5 ... +50
Certification	c UL us – Recognized (OL)
CE marking (see declaration of conformity)	In accordance with EU Low Voltage Directive (not for VABS-S4...R3 and variants of width 52, VABS-S2-2S...)
Degree of protection	IP65, NEMA 4 (for all types of signal transmission when mounted)

Datasheet – Valves on individual sub-base

Standard nominal flow rate of valve/individual sub-base [l/min]				
Valve function (with valve code)	Width 18 mm		Width 26 mm	
	Valve	Valve on individual sub-base	Valve	Valve on individual sub-base
5/2-way double solenoid (B52)	750	600	1400	1200
5/2-way double solenoid with dominant signal (D52)	750	600	1400	1200
5/2-way single solenoid, pneumatic spring (M52A)	750	600	1400	1200
5/2-way single solenoid, mechanical spring (M52M)	750	600	1400	1200
5/3-way closed (P53C)	700	550	1400 ¹⁾ 700 ²⁾	1200 ¹⁾ 700 ²⁾
5/3-way exhausted (P53E)	700 ¹⁾ 330 ²⁾	500 ¹⁾ 330 ²⁾	1400 ¹⁾ 700 ²⁾	1200 ¹⁾ 700 ²⁾
5/3-way pressurised (P53U)	700 ¹⁾ 330 ²⁾	500 ¹⁾ 330 ²⁾	1400 ¹⁾ 700 ²⁾	1200 ¹⁾ 700 ²⁾
5/3-way exhausted, switching position 14 detenting (P53ED)	–	390 ¹⁾ 310 ²⁾	1400 ¹⁾ 700 ²⁾	1200 ¹⁾ 700 ²⁾
5/3-way exhausted, switching position 12 detenting (P53EP)	–	390 ¹⁾ 320 ²⁾	1400 ¹⁾ 700 ²⁾	1200 ¹⁾ 700 ²⁾
5/3-way, port 2 pressurised, 4 exhausted, switching position 14 detenting (P53AD)	–	380 ¹⁾ 360 ²⁾	700 ¹⁾ 700 ²⁾	700 ¹⁾ 700 ²⁾
5/3-way, port 4 pressurised, 2 exhausted, switching position 14 detenting (P53BD)	–	400	–	900 ¹⁾ 840 ²⁾
2x3/2-way single solenoid, closed (T32C)	600	500	1250	1100
2x3/2-way single solenoid, open (T32U)	600	500	1250	1100
2x3/2-way single solenoid, open/closed (T32H)	600	500	1250	1100
2x3/2-way single solenoid, closed (T32N)	600	500	1250	1100
2x3/2-way single solenoid, open (T32F)	600	500	1250	1100
2x3/2-way single solenoid, open/closed (T32W)	600	500	1250	1100
2x2/2-way single solenoid, closed (T22C)	700	500	1350	1100
2x2/2-way single solenoid, closed (T22CV)	700	500	1350	1100

1) Switching position

2) Mid-position

Datasheet – Valves on individual sub-base

Standard nominal flow rate of valve/individual sub-base [l/min] Valve function (with valve code)	Width 42 mm		Width 52 mm	
	Valve	Valve on individual sub-base	Valve	Valve on individual sub-base
5/2-way double solenoid (B52)	2000	1500	4000	3400
5/2-way double solenoid with dominant signal (D52)	2000	1500	4000	3400
5/2-way single solenoid, pneumatic spring (M52A)	2000	1500	4000	3400
5/2-way single solenoid, mechanical spring (M52M)	2000	1500	4000	3400
5/3-way closed (P53C)	1900 ¹⁾ 950 ²⁾	1400 ¹⁾ 800 ²⁾	3600 ¹⁾ 1700 ²⁾	3200 ¹⁾ 1700 ²⁾
5/3-way exhausted (P53E)	1900 ¹⁾ 950 ²⁾	1400 ¹⁾ 800 ²⁾	3600 ¹⁾ 1700 ²⁾	3200 ¹⁾ 1700 ²⁾
5/3-way pressurised (P53U)	1900 ¹⁾ 950 ²⁾	1400 ¹⁾ 800 ²⁾	3600 ¹⁾ 1700 ²⁾	3200 ¹⁾ 1700 ²⁾
5/3-way, 1 to 2 pressurised, 4 to 5 closed (P53F)3)	1700 ¹⁾ 700 ²⁾	1400 ¹⁾ 700 ²⁾	3000 ¹⁾ 900 ²⁾	2600 ¹⁾ 900 ²⁾
2x3/2-way single solenoid, closed (T32C)	1600	1200	3000	2600
2x3/2-way single solenoid, open (T32U)	1600	1200	3000	2600
2x3/2-way single solenoid, open/closed (T32H)	1600	1200	3000	2600
2x3/2-way single solenoid, closed (T32N)	1600	1200	3000	2600
2x3/2-way single solenoid, open (T32F)	1600	1200	3000	2600
2x3/2-way single solenoid, open/closed (T32W)	1600	1200	3000	2600
2x2/2-way single solenoid, closed (T22C)	1600	1400	4000	3400
2x2/2-way single solenoid, closed (T22CV)	1600	1400	–	–

1) Switching position

2) Mid-position

3) The valve function P53F is only available in the 24 V DC version. Values only apply to 24 V DC.

Electrical data – Individual sub-base

Current rating at 40 °C	[A]	2 (1 A per coil)
Degree of protection to EN 60529		IP65, NEMA 4 (for all types of signal transmission when mounted)
Variants with cable connector		
Operating voltage range	[V DC]	24 ±10% (for variants with cable clamps VABS-...-K1/C1, ...-K2)
	[V AC]	110 ±10% (50 ... 60Hz) (for variants with cable and spring-loaded terminal VABS-...-K1/C1, ...-K2)
Surge resistance	[kV]	4
Pollution degree		3
Duty cycle	[ED]	100%

**Note**

A cable connector is needed to ensure the IP degree of protection and to protect against tensile load, twisting and bending.

Datasheet – Valves on individual sub-base

Materials				
Width	18 mm	26 mm	42 mm	52 mm
Sub-base	Die-cast aluminium			Gravity die-cast aluminium
Valve	Die-cast aluminium, PA			
Seals	FPM, NBR			
Note on materials	RoHS-compliant			

Product weight [g]				
Width	18 mm	26 mm	42 mm	52 mm
Valves				
5/2-way solenoid valve, Double solenoid	172	276	439	732
5/2-way valve, single solenoid	163	293	426	702
5/3-way solenoid valve (P53C, P53E, P53U)	191	320	456	780
5/3-way solenoid valve (P53BD)	172	301	–	–
5/3-way solenoid valve (P53ED, P53EP)	170	291	–	–
5/3-way solenoid valve (P53AD)	172	301	–	–
5/3-way solenoid valve (P53F)	–	–	456	780
2x 3/2-way solenoid valve	190	335	442	740
2x 2/2-way solenoid valve	190	335	442	740
Individual connection				
Individual sub-base	192	302	386	815

Datasheet – Valves on individual sub-base

Dimensions

Download CAD data → www.festo.com

Individual sub-base with cable clamps, width 18 mm

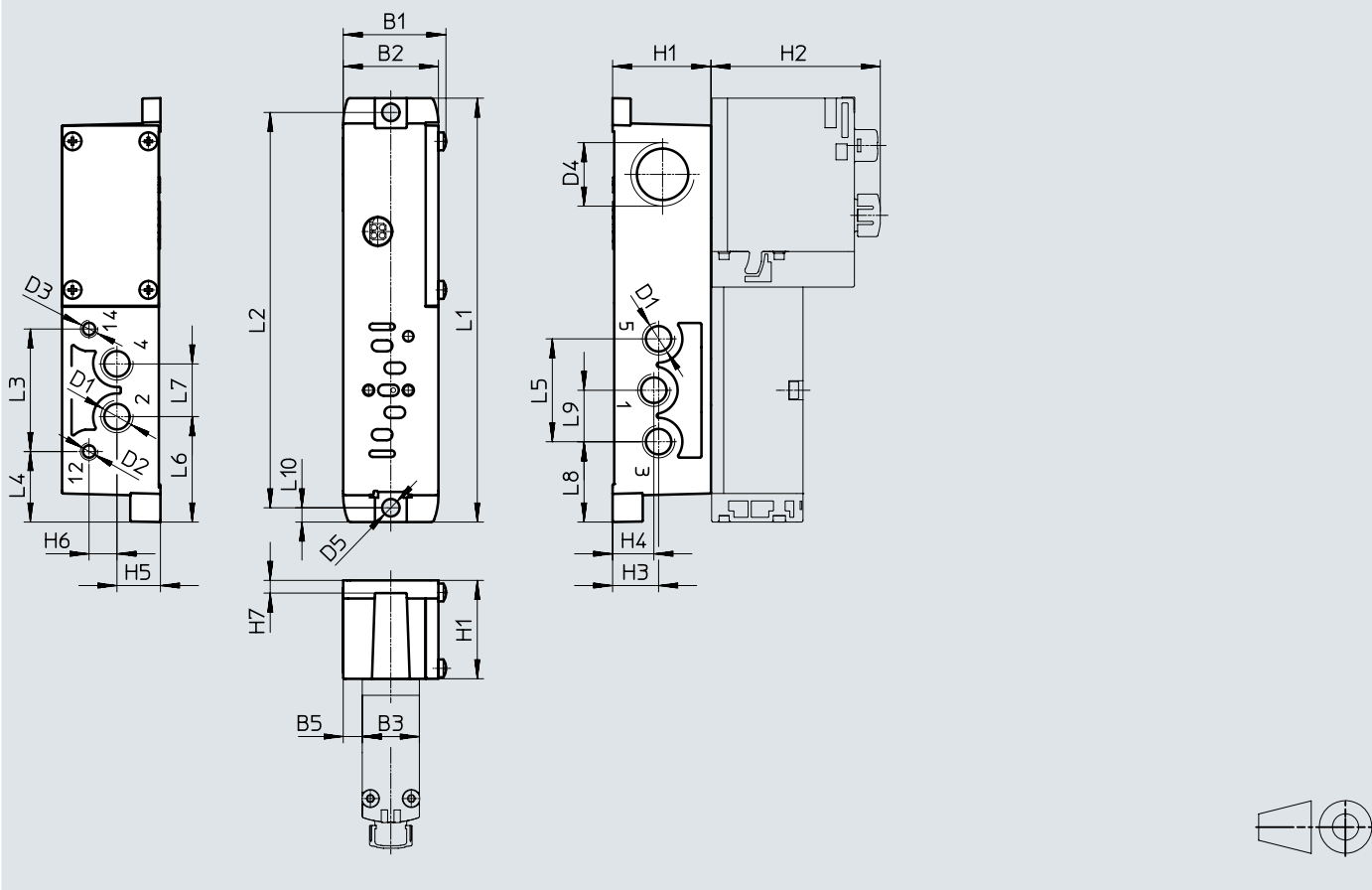

Type	B1	B2	B3	B5	D1	D2	D3	D4	D5 ø	H1	H2	H3	H4	H5	H6	H7
VABS-S4-2S-N18-K2 ¹⁾	32.4	30	18	6	1/8 NPT	10-32UNF-2B	10-32UNF-2B	M20x1.5	5.5	31	53.4	14.5	13	13.7	8.8	4
VABS-S4-2S-N18-B-K2 ²⁾							-									

Type	L1	L2	L3	L4	L5	L6	L7	L8	L9	L10
VABS-S4-2S-N18-K2 ¹⁾	133.5	124.5	38.6	22.2	32.4	33.2	16.6	25.3	16.2	4.5
VABS-S4-2S-N18-B-K2 ²⁾										

1) External pilot air supply

2) Internal pilot air supply

† Note: This product conforms to ISO 1179-1 and ISO 228-1.

Datasheet – Valves on individual sub-base

Dimensions

Download CAD data → www.festo.com

Individual sub-base with cable clamps, width 26 mm

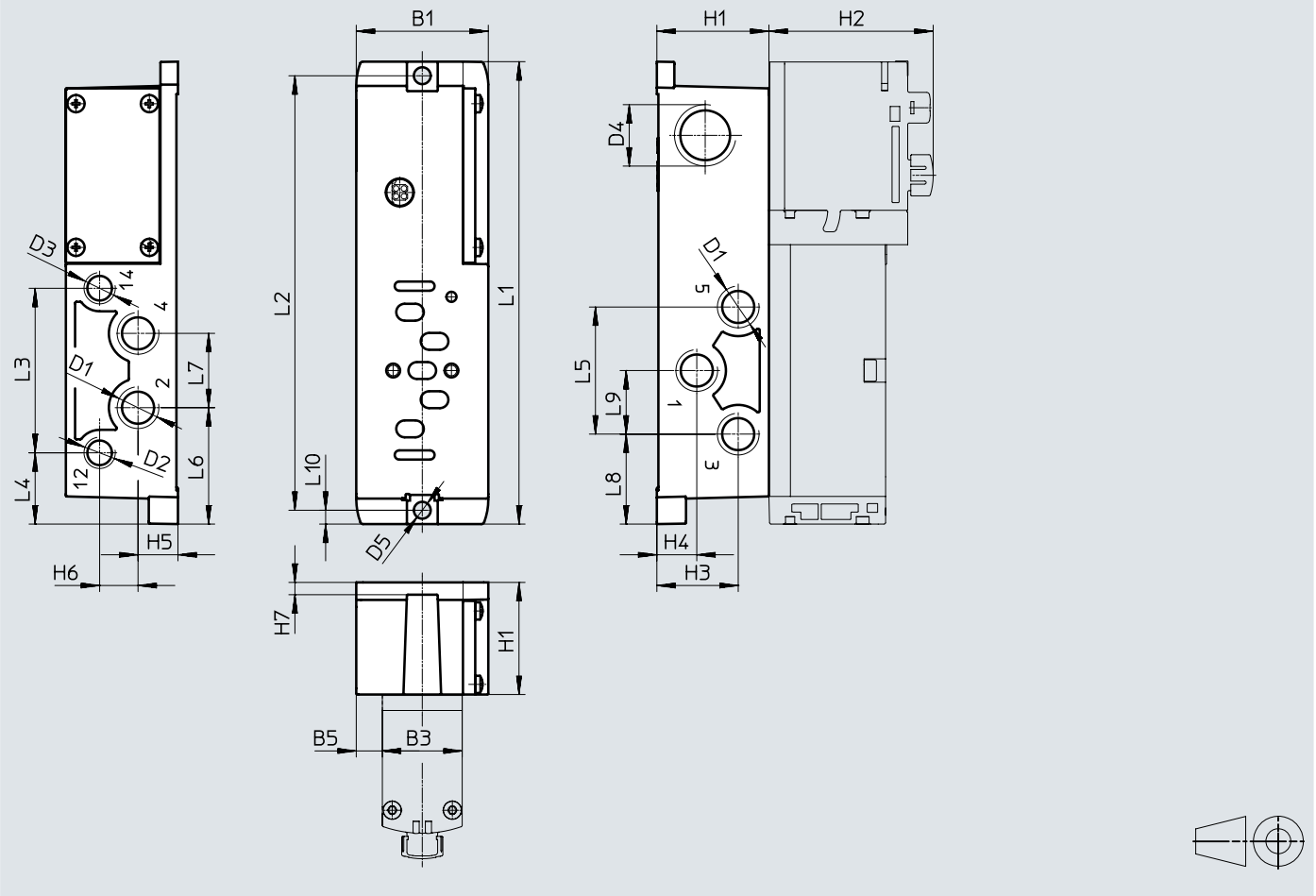

Type	B1	B3	B5	D1	D2	D3	D4	D5 ø	H1	H2	H3	H4	H5	H6	H7
VABS-S4-1S-G14-K2 ¹⁾	43	26	8.5	1/4 NPT	1/8 NPT	1/8 NPT	M20x1.5	5.5	36.5	53.5	26.5	13	13	12.5	4
VABS-S4-1S-G14-B-K2 ²⁾						-									

Type	L1	L2	L3	L4	L5	L6	L7	L8	L9	L10
VABS-S4-1S-G14-K2 ¹⁾	150.6	141.5	53.6	23.2	41.4	37.9	24.2	29.3	20.7	4.5
VABS-S4-1S-G14-B-K2 ²⁾										

- 1) External pilot air supply
- 2) Internal pilot air supply

† Note: This product conforms to ISO 1179-1 and ISO 228-1.

Datasheet – Valves on individual sub-base

Dimensions

Download CAD data → www.festo.com

Individual sub-base with spring-loaded terminal or for assembly by the user, width 42 mm

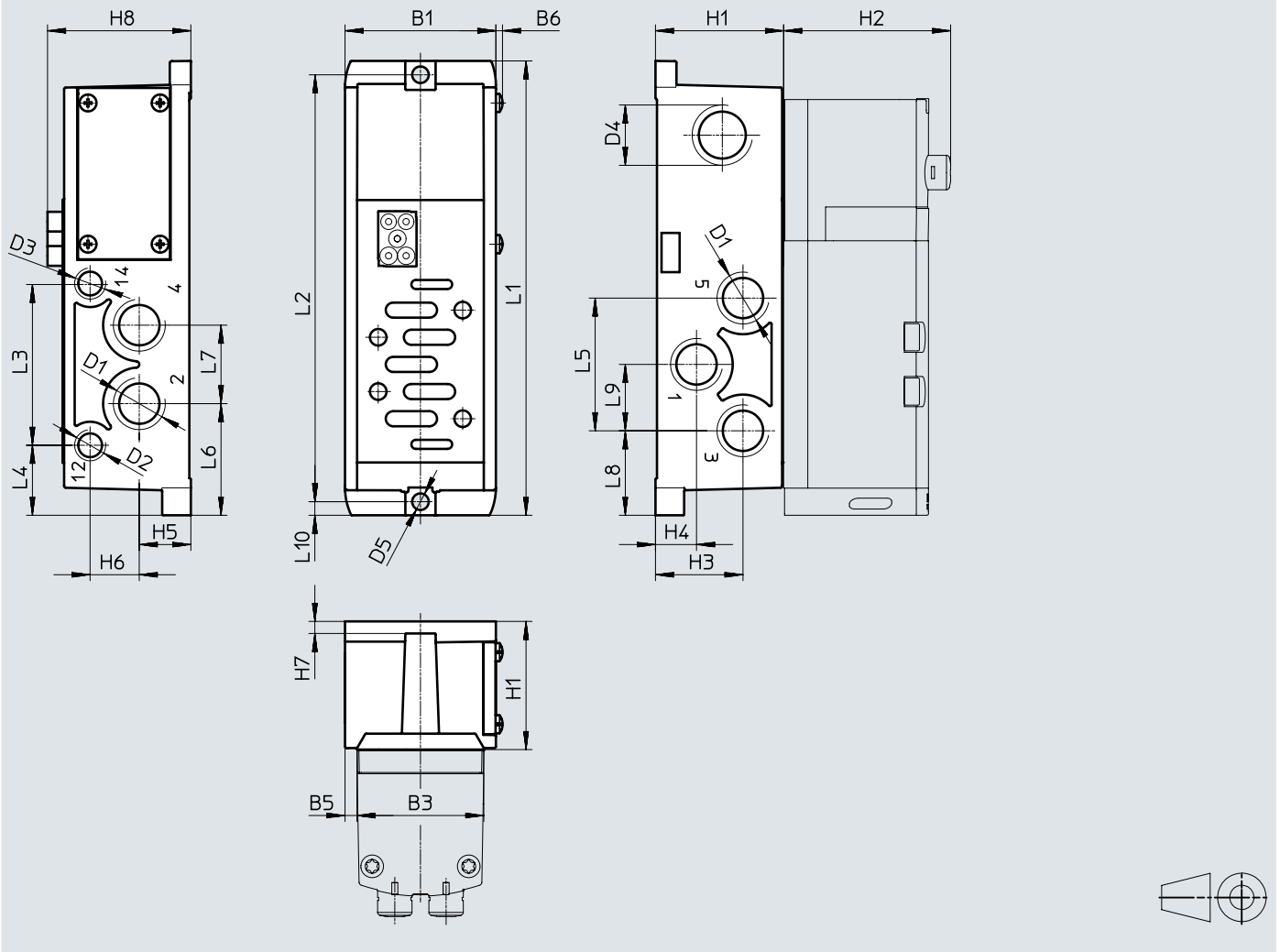

Type	B1	B3	B5	B6	D1	D2	D3	D4	D5 ø	H1	H2	H3	H4	H5	H6	H7	H8
VABS-S2-1S-N38-K1 ¹⁾	50	42	4	2.2	3/8 NPT	1/8 NPT	1/8 NPT	M20x1.5	5.5	42.5	55.3	29	13.6	17.1	16.3	4	47.5
VABS-S2-1S-N38-C1 ¹⁾																	
VABS-S2-1S-N38-B-K1 ²⁾							-										
VABS-S2-1S-N38-B-C1 ²⁾																	

Type	L1	L2	L3	L4	L5	L6	L7	L8	L9	L10
VABS-S2-1S-N38-K1 ¹⁾	150.6	141.5	53.6	23.2	44	37	26	28	22	4.5
VABS-S2-1S-N38-C1 ¹⁾										
VABS-S2-1S-N38-B-K1 ²⁾										
VABS-S2-1S-N38-B-C1 ²⁾										

1) External pilot air supply

2) Internal pilot air supply

† Note: This product conforms to ISO 1179-1 and ISO 228-1.

Datasheet – Valves on individual sub-base

Dimensions

Download CAD data → www.festo.com

Individual sub-base with M12 plug, width 52 mm

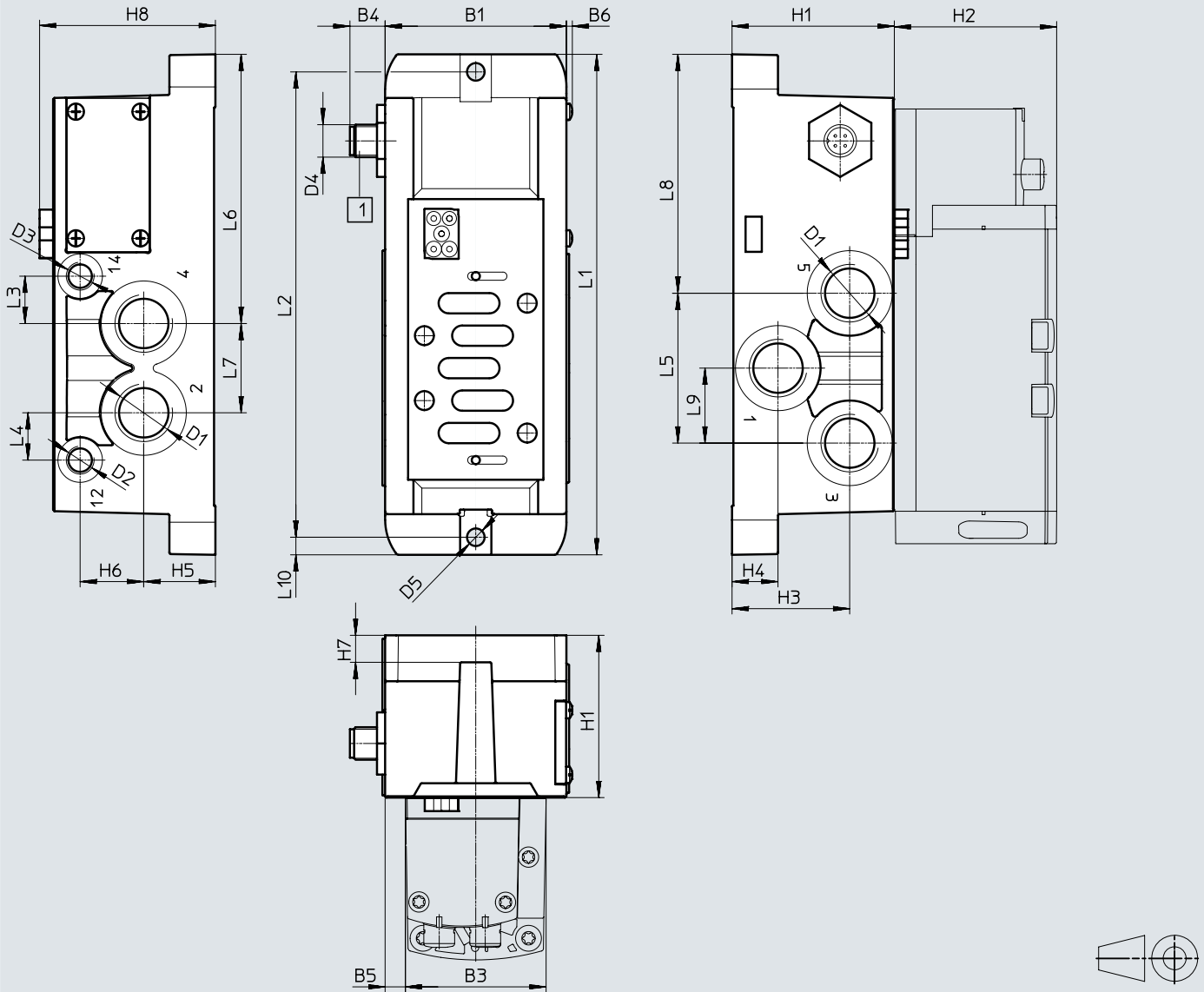

[1] Plug to EN 61076-2-101

Type	B1	B3	B5	B6	D1	D2	D3	D4	D5 ø	H1	H2	H3	H4	H5	H6	H7	H8
VABS-S2-2S-N12-K1 ¹⁾	67	52	7.5	2.2	1/2 NPT	1/8 NPT	1/8 NPT	M20x1.5	6.5	60	60	43.5	17	26.5	23.5	10	65
VABS-S2-2S-N12-C1 ¹⁾																	
VABS-S2-2S-N12-B-K1 ²⁾							-										
VABS-S2-2S-N12-B-C1 ²⁾																	

Type	L1	L2	L3	L4	L5	L6	L7	L8	L9	L10
VABS-S2-2S-N12-K1 ¹⁾	185	172	17.5	17.5	55.4	99.5	33	88.3	27.7	6.5
VABS-S2-2S-N12-C1 ¹⁾										
VABS-S2-2S-N12-B-K1 ²⁾										
VABS-S2-2S-N12-B-C1 ²⁾										

1) External pilot air supply
2) Internal pilot air supply

‡ Note: This product conforms to ISO 1179-1 and ISO 228-1.

Accessories – Individual connection

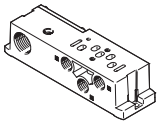
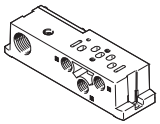
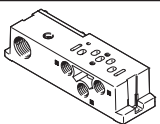

Ordering data	Description	Width	Part no.	Type	
Individual sub-base, electrical connection via cable clamps					
	Internal pilot air supply	1/8 NPT connections	18 mm	541068	VABS-S4-2S-N18-B-K2
		1/4 NPT connections	26 mm	541066	VABS-S4-1S-N14-B-K2
	External pilot air supply	1/8 NPT connections	18 mm	539724	VABS-S4-2S-N18-K2
		1/4 NPT connections	26 mm	539726	VABS-S4-1S-N14-K2
Individual sub-base, electrical connection via spring-loaded terminal					
	Internal pilot air supply	3/8 NPT connections	42 mm	546763	VABS-S2-1S-N38-B-C1
		1/2 NPT connections	52 mm	555644	VABS-S2-2S-N12-B-C1
	External pilot air supply	3/8 NPT connections	42 mm	546761	VABS-S2-1S-N38-C1
		1/2 NPT connections	52 mm	555639	VABS-S2-2S-N12-C1
Individual sub-base, electrical connection via cable (open end)					
	Internal pilot air supply	3/8 NPT connections	42 mm	546103	VABS-S2-1S-N38-B-K1
		1/2 NPT connections	52 mm	555642	VABS-S2-2S-N12-B-K1
	External pilot air supply	3/8 NPT connections	42 mm	546100	VABS-S2-1S-N38-K1
		1/2 NPT connections	52 mm	555637	VABS-S2-2S-N12-K1
Pneumatic connection accessories					
A selection of possible fittings, blanking plugs, silencers and other pneumatic accessories can be found in the chapter "Accessories" → page: 190					

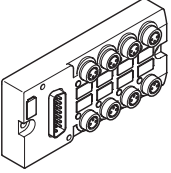
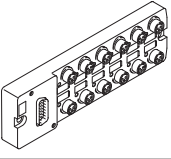
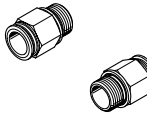
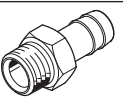
Accessories

Ordering data		Description	Part no.	Type	PU ¹⁾
Multi-pin plug distributor					
	15-pin Sub-D socket on 8x 3-pin M8 plugs		177669	MPV-E/A08-M8	1
	15-pin Sub-D socket on 12x 3-pin M8 plugs		177670	MPV-E/A12-M8	1
Push-in fitting					
	Connecting thread 1/4 NPT for tubing O.D.	1/2"	567771	QB-1/4-1/2-U	10
		3/8"	533278	QB-1/4-3/8-U	10
		5/16"	533277	QB-1/4-5/16-U	10
	Connecting thread 1/8 NPT for tubing O.D.	3/8"	567773	QB-1/8-3/8-U	10
		1/4"	533273	QB-1/8-1/4-U	10
		5/16"	533274	QB-1/8-5/16-U	10
	Connecting thread 3/8 NPT for tubing O.D.	1/2"	533282	QB-3/8-1/2-U	5
		3/8"	533281	QB-3/8-3/8-U	5
	Connecting thread 1/2 NPT for tubing O.D.	5/8"	190682	QS-1/2-5/8-U	1
		1/2"	533284	QB-1/2-1/2-U	5
Barbed hose fitting					
	For right end plate (connecting thread NPT)	3/4"	564848	N-3/4-P-19-NPT	1
		R1	572243	N-1-P-19-NPT	1
	For adapter plate (connecting thread NPT)	R1	572243	N-1-P-19-NPT	1

1) Packaging unit

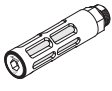
Accessories

Ordering data		Code	Description	Part no.	Type	PU ¹⁾
Silencer						
	U	Standard design, connecting thread NPT	1/8"	12638	U-1/8-B-NPT	1
			1/4"	12639	U-1/4B-NPT	1
			1/2"	12741	U-1/2-B-NPT	1
			3/4"	566823	U-3/4-B-NPT	1
			1"	571280	U-1-B-NPT	1
	A	Sintered design, connecting thread NPT	1/8"	1206989	AMTE-M-LH-N18	20
			1/4"	1206990	AMTE-M-LH-N14	20
			1/2"	1206992	AMTE-M-LH-N12	10
Blanking plug						
	-	Connecting thread NPT	1/8"	173985	B-1/8-NPT	1
			1/4"	174165	B-1/4-NPT	1
			1/2"	31785	B-1/2-NPT	1
			3/4"	31786	B-3/4-NPT	1
			1"	31787	B-1-NPT	1
Other pneumatic connection accessories						
A selection of possible fittings, blanking plugs and silencers can be found on the website via the individual search terms: Internet → connection technology, silencer, blanking plug						

1) Packaging unit