

Planar surface gantries EXCH

FESTO



Key features

At a glance

General

- Optimal dynamic response when compared with other Cartesian gantry systems
- The drive concept ensures low moving dead weight
- Flat system design
- Flexible motor mountings
- High acceleration in both axis directions

Application examples

- Fast repositioning of parts and modules in a large, rectangular working space, e.g.:
 - Sorting
 - Loading, unloading
 - Gluing, cutting

Functional principle

A slide is moved in a two-dimensional space (XY-axis) via a toothed belt. The system is powered by two fixed motors. The motors are coupled to the toothed belt. The belt is guided via guide pulleys so that the slide can move to any position in a working space when the motors are actuated accordingly.

When using attachment components, additional processes can be carried out by independent Z-axes.

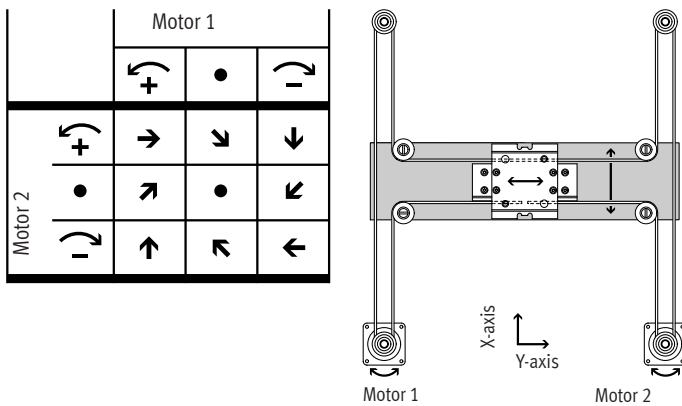

Note
Additional multi-axis controller required for interpolation (e.g. CPX-E-CEC-M1-...).

Type		EXCH-40	EXCH-60
Guide		Recirculating ball bearing guide	
Stroke of the			
X-axis	[mm]	200 ... 2000	500 ... 2500
Y-axis	[mm]	200 ... 1000	500 ... 1500
Z-axis	[mm]	50, 100, 150, 200	
Rated load at max. dynamic response ¹⁾	[kg]	4	6
Max. speed			
Horizontal	[m/s]	5	5
Vertical	[m/s]	4	3
Max. acceleration			
Horizontal	[m/s ²]	50	
Vertical	[m/s ²]	30	
Repetition accuracy ²⁾	[mm]	±0.1	
Mounting position ³⁾		Horizontal or vertical	

1) Rated load = tool load (attachment component (Z-axis) + e.g. gripper) + payload
 2) The repetition accuracy relates to the centre point of the slide
 3) Vertical mounting position only permitted with motors with brake and braking resistors

Key features

Motor attachment variants

Sample product image,
motors not included in the scope of delivery!

EXCH-...-B – Motor underneath

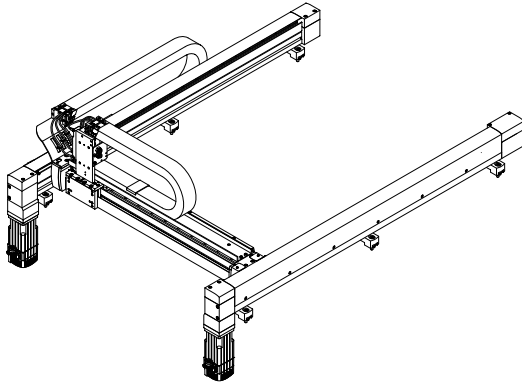

EXCH-...-T – Motor on top

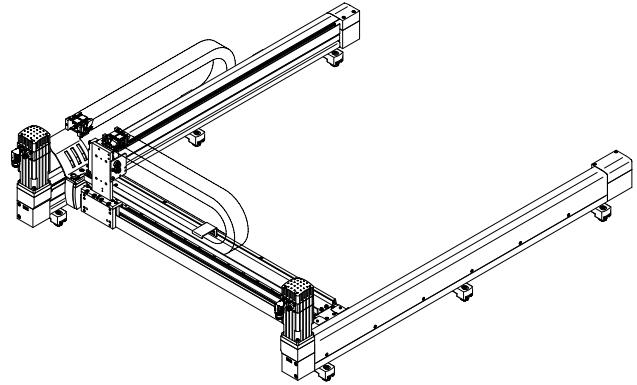

Mounting positions

Horizontal

- Installation always with the energy chain overhead

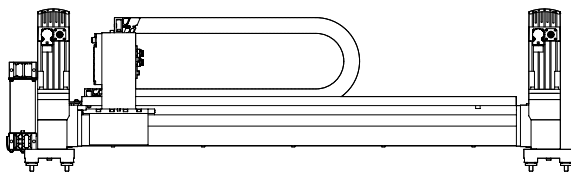

Vertical

- Only the X-axes may be installed
- Only use motors with brake
- Motors must be on top so that the energy chain can hang freely

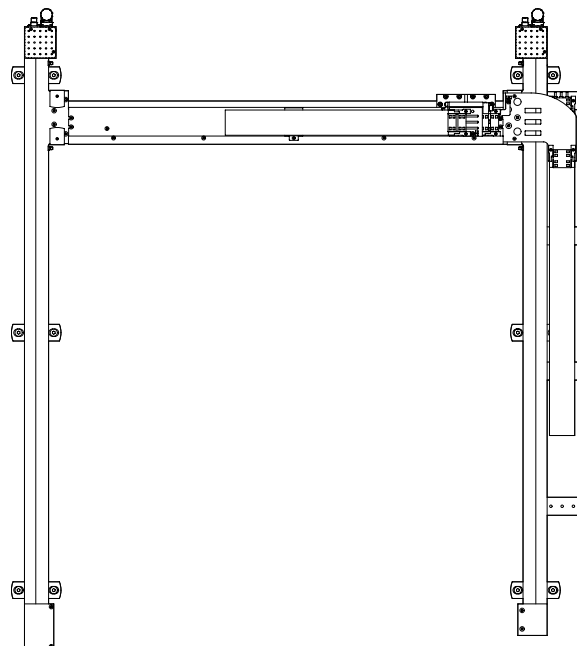

Note

During commissioning, the motor brake must be released for safety purposes.

Key features

Selection of attachment components

Without attachment component

The following are already installed on delivery:

- [1] 2 supply ports for e.g. Z-axis
- [2] Multi-pin plug distributor (6-way) for bundling signals:
 - e.g. proximity switch

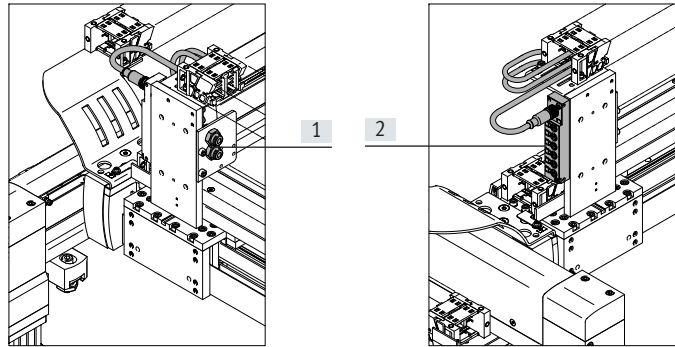

Additional information → page 15

Type codes

001	Series
EXCH	Planar surface gantry

002	Size
40	40
60	60

003	Stroke of the X-axis [mm]
200	200
2500	2500

004	Stroke of the Y-axis [mm]
200	200
1500	1500

005	Guide
KF	Recirculating ball bearing guide

006	Motor type
W	Without motor

007	Motor attachment position
B	Underneath
T	Top

008	Energy chain connection side
L	Left

009	Attachment components
T0	None

010	Cable length
5K	5 m
10K	10 m

011	Mounting kit
P	With mounting kit
	With adjusting kit

Peripherals overview

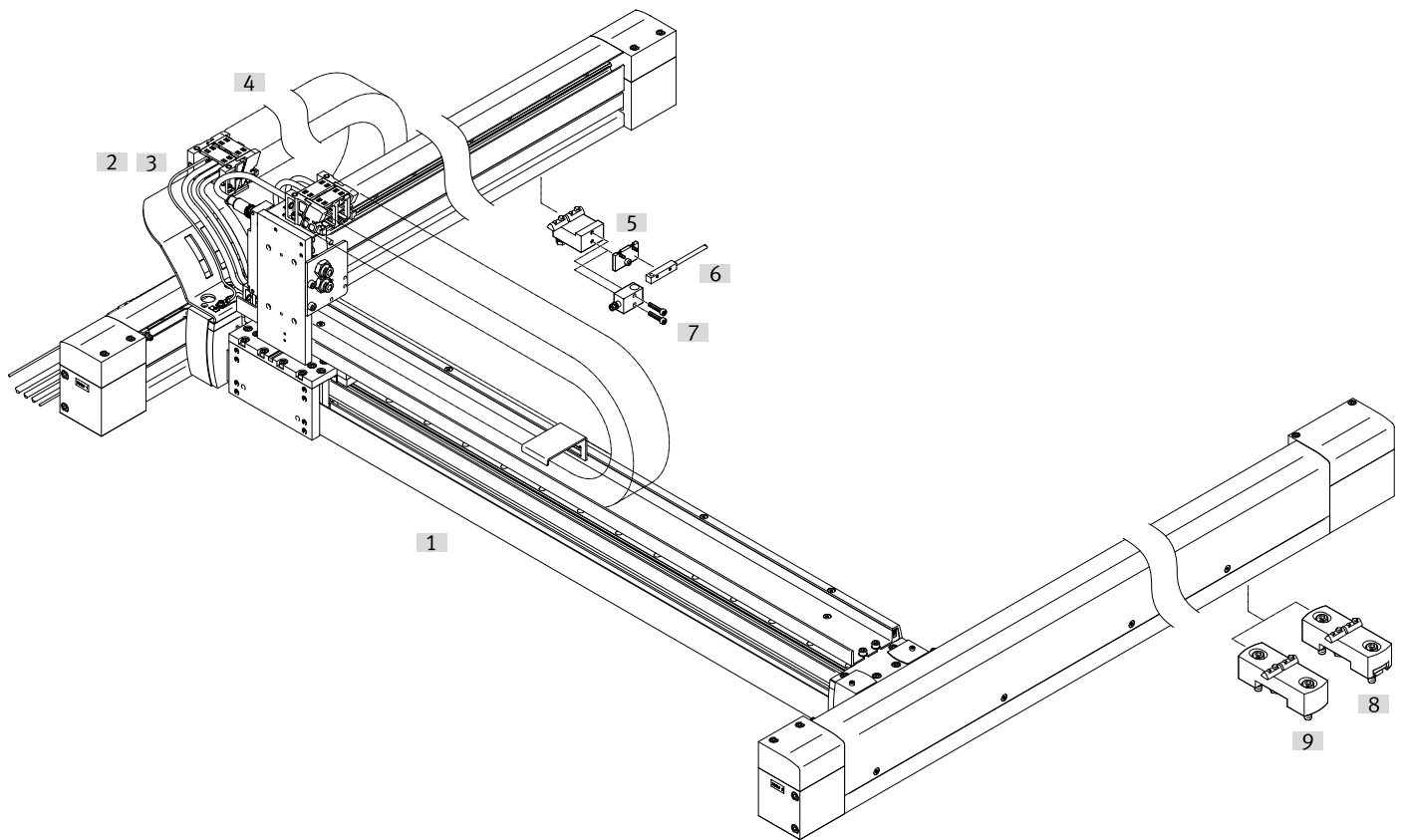

Proximity switch for sensing the position of the slide on the Y-axis

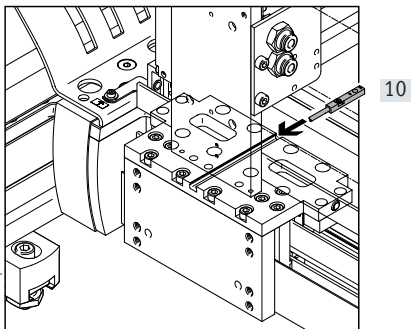

Peripherals overview

Attachments and accessories			
Type	Description		→ Page/Internet
[1] Planar surface gantry EXCH	–		8
[2] Multi-pin plug distributor NEDU	<ul style="list-style-type: none"> For connecting up to 6 inputs/outputs Included in the scope of delivery of the planar surface gantry 		nedu
[3] Plug socket with cable SIM	<ul style="list-style-type: none"> Connecting cable between multi-pin plug distributor NEDU and the controller Included in the scope of delivery of the planar surface gantry 		sim
[4] Energy chain	<ul style="list-style-type: none"> For EXCH-40: type IGUS E6.29.040.075.0 For EXCH-60: type IGUS E6.35.050.075.0 		–
[5] Sensor mounting EAPR	<ul style="list-style-type: none"> For mounting the proximity switches SIES-Q8B, SIES-V3B on the X-axis Not included in the scope of delivery of the planar surface gantry 		26
[6] Proximity switch SIES-Q8B	<ul style="list-style-type: none"> For position sensing on the X-axis Not included in the scope of delivery of the planar surface gantry 		27
[7] Proximity switch SIES-V3B	<ul style="list-style-type: none"> For position sensing on the X-axis Not included in the scope of delivery of the planar surface gantry 		27
[8] Mounting kit EAHM-E12	<ul style="list-style-type: none"> Non-height-adjustable mounting kit for the planar surface gantry 		26
[9] Adjusting kit EADC-12	<ul style="list-style-type: none"> Height-adjustable mounting kit for the planar surface gantry Included in the scope of delivery of the planar surface gantry. If no adjusting kit is selected in the modular product system, the mounting kit will automatically be delivered 		26
[10] Proximity switch SIES-8M	<ul style="list-style-type: none"> For position sensing on the Y-axis Not included in the scope of delivery of the planar surface gantry 		27
– Plastic tubing PUN-H-6x1	<ul style="list-style-type: none"> Two pieces of tubing are connected to the bulkhead fittings and routed in the energy chains on delivery 		pun

Datasheet

Size
40, 60

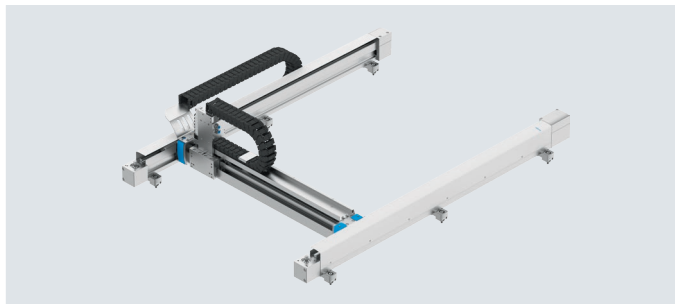

General technical data		40	60
Size		40	60
Design		Planar surface gantry	
Guide		Recirculating ball bearing guide	
Stroke of the			
X-axis	[mm]	200 ... 2000	500 ... 2500
Y-axis	[mm]	200 ... 1000	500 ... 1500
Rated load at max. dynamic response ¹⁾	[kg]	4	6
Max. torque ²⁾	[Nm]	→ Page 12	
Max. no-load torque ²⁾³⁾	[Nm]	→ Page 12	
Max. acceleration ⁴⁾			
Horizontal	[m/s ²]	50	
Vertical	[m/s ²]	30	
Max. speed ⁴⁾			
Horizontal	[m/s]	5	
Vertical	[m/s]	4	3
Repetition accuracy	[mm]	±0.1	
Mounting position ⁵⁾		Horizontal or vertical	
Type of mounting		Mounting kit, adjusting kit	

- 1) Rated load = tool load (attachment component (Z-axis) + e.g. gripper) + payload
- 2) These values must also be complied with when installing third-party motors
- 3) At v=0.2 m/s and 45° travel.
- 4) This data applies only under ideal conditions.
For a precise configuration, please consult a sales engineer from Festo.
Additional information → page 12
- 5) Vertical installation only permitted with motors with brake and braking resistors

Factoring in software end positions

When selecting the strokes for the X- and Y-axis, the dimension L3 for the software end positions must be taken into account in addition to the working stroke L2. This dimension is freely selectable.

Adjusting pieces with L3 = 30 mm are included in the scope of delivery of the planar surface gantry.

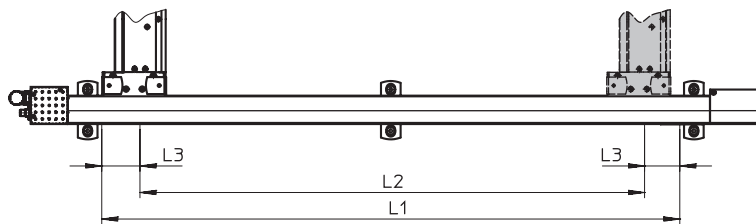

Stroke L1 = working stroke L2 + 2x software end position L3

Datasheet

Operating and environmental conditions			
Size		40	60
Degree of protection		IP40	
Ambient temperature ¹⁾	[°C]	+10 ... +50	
Storage temperature	[°C]	-10 ... +60	
CE marking (see declaration of conformity)		To EU Machinery Directive	
UKCA marking (see declaration of conformity)		To UK instructions for machines	
Relative humidity	[%]	0 ... 90 (non-condensing)	
Noise level	[dB(A)]	74	81
Duty cycle	[%]	100	

1) Note operating range of proximity switches and motors

Materials

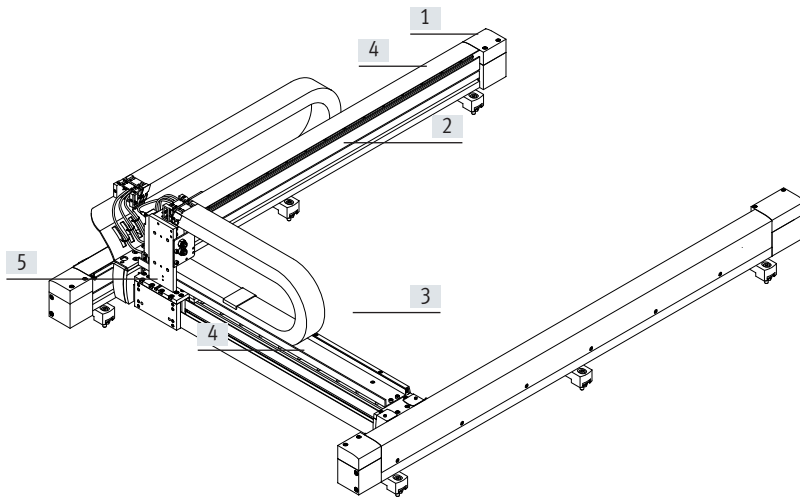

Size	40	60
[1] Drive and end caps	Aluminium	
[2] Profiles of the X-axis	Aluminium	
[3] Profile of the Y-axis	Aluminium	
[4] Covering		
X-axis	Aluminium	
Y-axis	Aluminium	
[5] Slide	Aluminium	
- Coupling	Aluminium with elastomer ring gear	Clamping hub: Aluminium Expanding mandrel hub: Stainless steel Ring gear: Elastomer
Guide	Steel	
Drive pinion	Steel	
Ball bearings	Steel	
Toothed belt	PU with steel cord	
Note on materials	RoHS-compliant Contains paint-wetting impairment substances	

Datasheet

Weight [kg]		
Size	40	60
Product weight at 0 mm stroke (without rated load, motors, axial kits, mounting kits)		
X-axis and Y-axis	16.6	37.9
Y-axis (without slide)	6.0	11.5
Slide of the Y-axis	1.5	2.5
Additional weight per 100 mm stroke		
X-axis	1.69	2.21
Y-axis	0.81	0.99
Mounting kit for X-axis		
Adjusting kit ¹⁾	0.78	0.89
Mounting kit ¹⁾	0.33	0.37

1) Weight per component

Toothed belt		
Size	40	60
Pitch	[mm] 3	5
Elongation	[%] 0.1	0.045
Reference force for elongation	[N] 200	300
Width	[mm] 20	30
Effective diameter	[mm] 27.69	39.79
Feed constant ¹⁾	[mm/rev] 87	125

1) Feed constant at 45° travel

 **Note**

Engineering software

Handling Guide Online

www.festo.com/handling-guide

Datasheet

Acceleration a as a function of the rated load m and stroke of the Y-axis

The following data applies to a horizontal mounting position. For a vertical mounting position, please get in touch with your local contact at Festo.

The centre of gravity of the slide is at the height of the slide in the Z-direction and in the centre of the slide in the X-/Y-directions.

EXCH-40

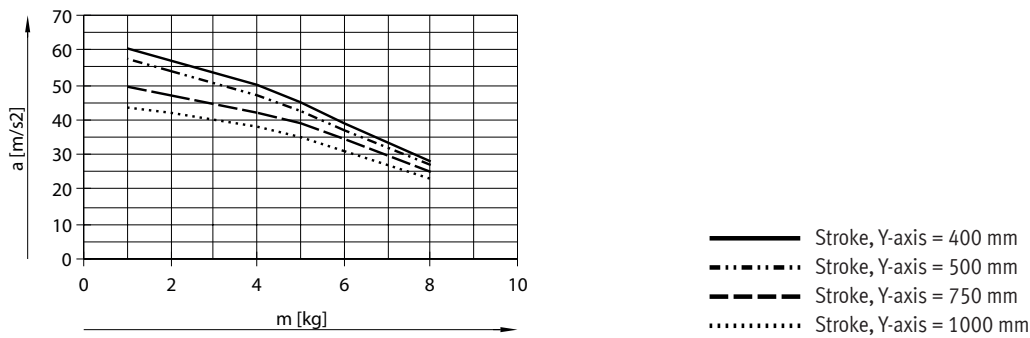

EXCH-60

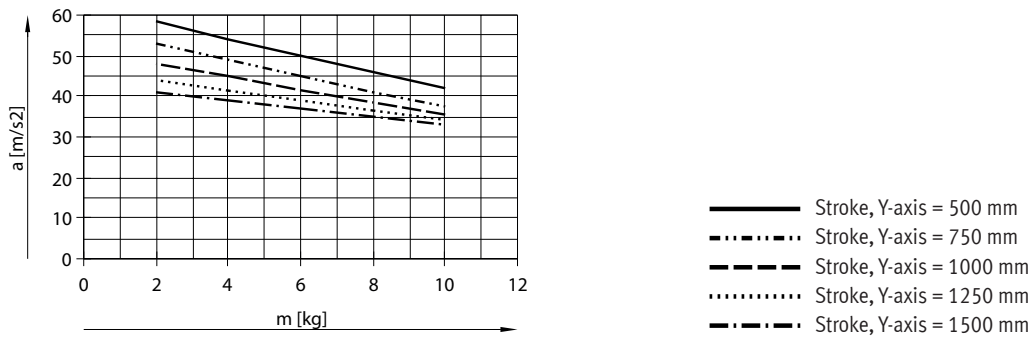

Datasheet

No-load torque M as a function of rotational speed n

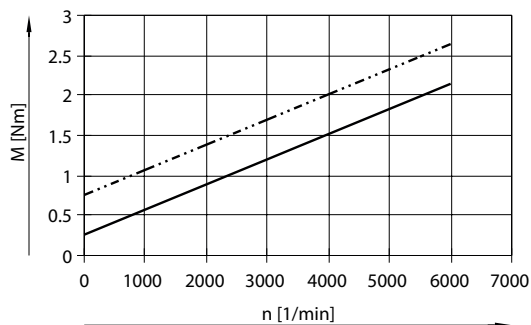

— EXCH-40
 - - - EXCH-60

Load values

The following data applies to a horizontal mounting position. For a vertical mounting position, please get in touch with your local contact at Festo.

The system is subject to the greatest load in the case of 45° travel. The following data apply in this case:

Formula for calculating the required torque M and the required nominal rotational speed n

For EXCH-40:

$$M_{45^\circ} = a \times (9.79 \times m_L + 4.89 \times m_{Ay} + 10.21 \times J_m + 19.58) \times 10^{-3} + M_R$$

$$n_{45^\circ} = 60000 / \text{feed constant}(\text{mm}) \times \sqrt{2} \times v_{\text{max}}(\text{m/s})$$

For EXCH-60:

$$M_{45^\circ} = a \times (14.07 \times m_L + 7.03 \times m_{Ay} + 7.11 \times J_m + 49.24) \times 10^{-3} + M_R$$

$$n_{45^\circ} = 60000 / \text{feed constant}(\text{mm}) \times \sqrt{2} \times v_{\text{max}}(\text{m/s})$$

a = acceleration [m/s²]

v = speed [m/s]

m_{Ay} = product weight of the Y-axis [kg] → page 10

m_L = attachment component (Z-axis) [kg] with payload

J_m = moment of inertia of the motor [kgcm²]

M_R = no-load torque [Nm] → page 12

n_{45°} = nominal rotational speed at 45° travel [rpm]

Datasheet

Sample calculation

Assuming:

Planar surface gantry

EXCH-40-1000-500-KF-W-B-L-T0-...

$$a_{\max} = 25 \text{ m/s}^2$$

$$v_{\max} = 2 \text{ m/s}$$

Payload = 0.5 kg

Attachment component on Z-axis: EGSL-BS-45-100-10P

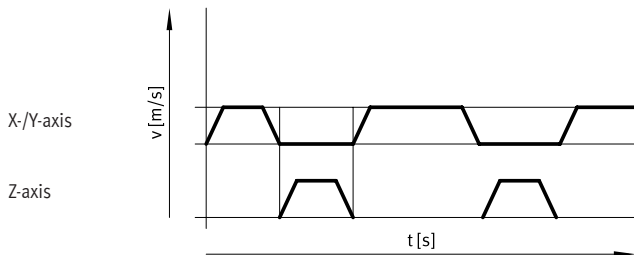

Calculation:

1. What is the max. acceleration permitted by the mechanical system?

Moving mass m_L on the Y-axis:

Z-axis 3.40 kg

Payload 0.50 kg
= 3.90 kg

Stroke of the Y-axis:

500 mm

Results:

With a moving mass m_L of 3.9 kg, the maximum permissible acceleration is 46 m/s^2 .

The required acceleration of 25 m/s^2 is thus permissible.

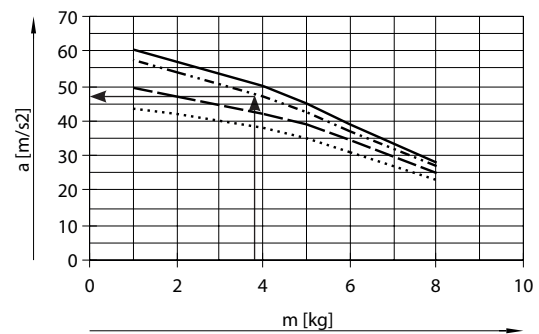

- Stroke, Y-axis = 400 mm
- Stroke, Y-axis = 500 mm
- - - Stroke, Y-axis = 750 mm
- · - · Stroke, Y-axis = 1000 mm

Note

The following data applies to a horizontal mounting position. For a vertical mounting position, please get in touch with your local contact at Festo.

The centre of gravity of the slide is at the height of the slide in the Z-direction and in the centre of the slide in the X-/Y-directions.

Datasheet

Sample calculation

2. Is the attached motor sufficient for this load?

Assuming:

$$a_{\max} = 25 \text{ m/s}^2$$

$$v_{\max} = 2 \text{ m/s}$$

$$m_{Ay} = 10.05 \text{ kg}$$

$$m_L = 3.90 \text{ kg}$$

$$J_m = 3.085 \text{ kgcm}^2$$

$$M_{45^\circ} = a \times (9.79 \times m_L + 4.89 \times m_{Ay} + 10.21 \times J_m + 19.58) \times 10^{-3} + M_R$$

$$n_{45^\circ} = 60000 / \text{feed constant}(\text{mm}) \times \sqrt{2} \times v_{\max}(\text{m/s})$$

a = acceleration [m/s²]

v = speed [m/s]

m_{Ay} = product weight of the Y-axis [kg] → page 10

m_L = attachment component (Z-axis) [kg] with payload

J_m = moment of inertia of the motor [kgcm²] → table below

M_R = no-load torque [Nm] → page 12

n_{45° = nominal rotational speed at 45° travel [rpm]

Note
These requirements for the dynamic response apply to 45° travel.
The dynamic values may be higher for travel only in the X- or Y-direction.

Determining M_{45°

$$n_{45^\circ} = 60000 / \text{feed constant}(\text{mm}) \times \sqrt{2} \times v_{\max}(\text{m/s})$$

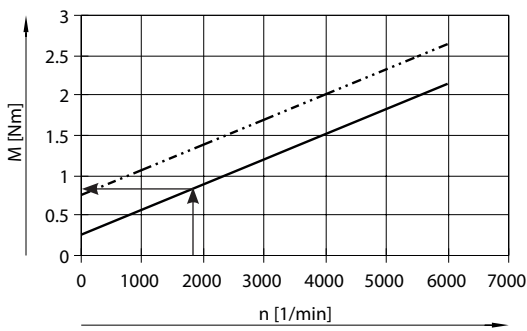

No-load torque:

— EXCH-40

- - - EXCH-60

$$M_R = 0.9 \text{ Nm}$$

$$M_{45^\circ} = a \times (9.79 \times m_L + 4.89 \times m_{Ay} + 10.21 \times J_m + 19.58) \times 10^{-3} + M_R$$

$$M_{45^\circ} = 25 \text{ m/s}^2 \times (9.79 \times 3.9 \text{ kg} + 4.89 \times 10.05 \text{ kg} + 10.21 \times 3.085 \text{ kgcm}^2 + 19.58) \times 10^{-3} + 0.9 \text{ Nm} = 4.36 \text{ Nm}$$

Results:

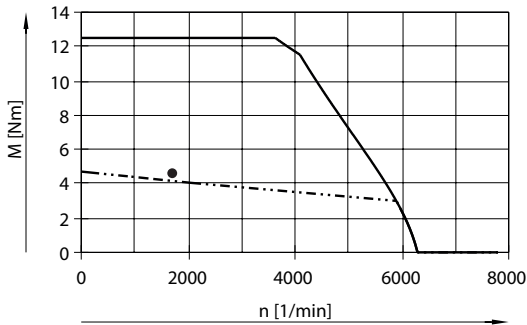

— Max. torque

- - - Nominal torque

Sample motor/servo drive characteristic!

The value for the torque is above the nominal torque and below the maximum torque.

This torque is only required in the acceleration phases.

The rms value of the torque for the particular positioning cycle must remain below the nominal torque.

Datasheet

Selection of attachment components

The gantry is delivered as standard in the configuration without attachment elements (EXCH-...-T0).

The engineering software "Handling Guide Online" can be used to configure the planar surface gantry with other attachment components, such as a pneumatic or electric Z-axis.

EXCH-...-T0... (without attachment component)

The following are pre-installed:

- 2 supply ports for e.g. Z-axis
- Multi-pin plug distributor for bundling signals:
 - e.g. proximity switch

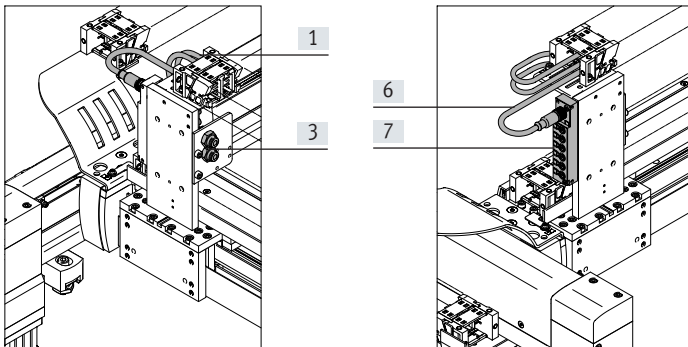

Components	Number of components
[1] Tubing	2
[3] Bulkhead fitting	2
[6] Plug socket with cable	1
[7] Multi-pin plug distributor (6-way)	1
– Earthing cable	2

Datasheet

Mounting position of attachment components

Due to manufacturing tolerances and the backlash in the guides, the angle between the mounting plane and the attachment component, e.g. Z-axis, may not be exactly 90° in certain circumstances.

Max. deviation:

EXCH-40: $\alpha = \pm 1.1^\circ$

EXCH-60: $\alpha = \pm 2.1^\circ$

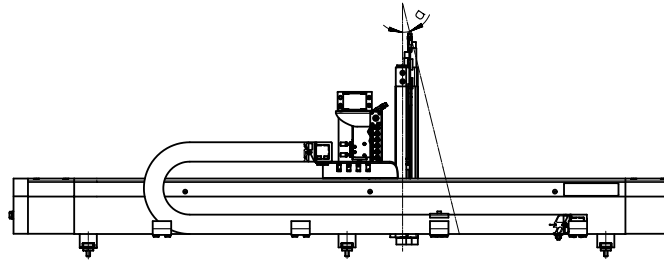

Selection of cable lengths

2 cable lengths (5 m or 10 m) can be selected using the modular product system → page 24. This specification relates to the output of the energy chain at the X-axis (dimension L) and describes the minimum length by which the cables and tubing protrude. The selected length applies to the following components:

- Tubing
- Plug sockets with cable

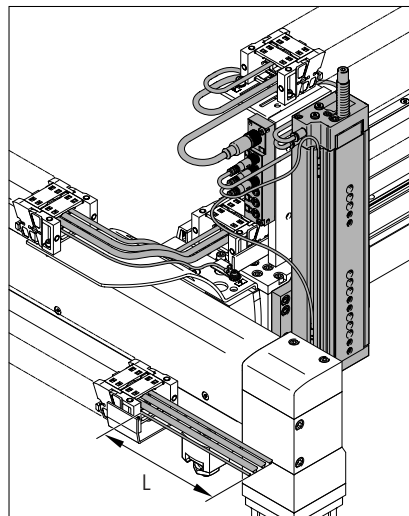

Sample product image

Datasheet

Number of profile mountings

Irrespective of the mounting position, a different number of profile mountings needs to be used depending on the stroke of the X-axis.

The required number is mounted on delivery.

Stroke of the X-axis [mm]	Number of profile mountings per axis	
	EXCH-40	EXCH-60
200 ... 499	2	-
500 ... 899	2	
900 ... 1799	3	
1800 ... 2000	4	
2000 ... 2500	-	4

Distances between the profile mountings

The profile mountings must be evenly spaced by distance l .

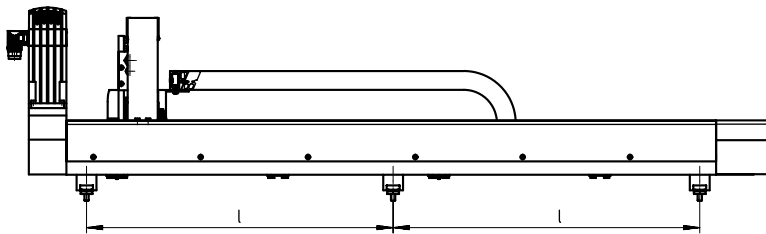

For EXCH-40

For EXCH-60

$$l_1 = \frac{l + 141}{n - 1}$$

$$l_1 = \frac{l + 328}{n - 1}$$

l_1 = distance

l = stroke

n = number of profile mountings per axis

Datasheet

Dimensions

Download CAD data → www.festo.com

EXCH-40-...-T – Motor mounting position on top

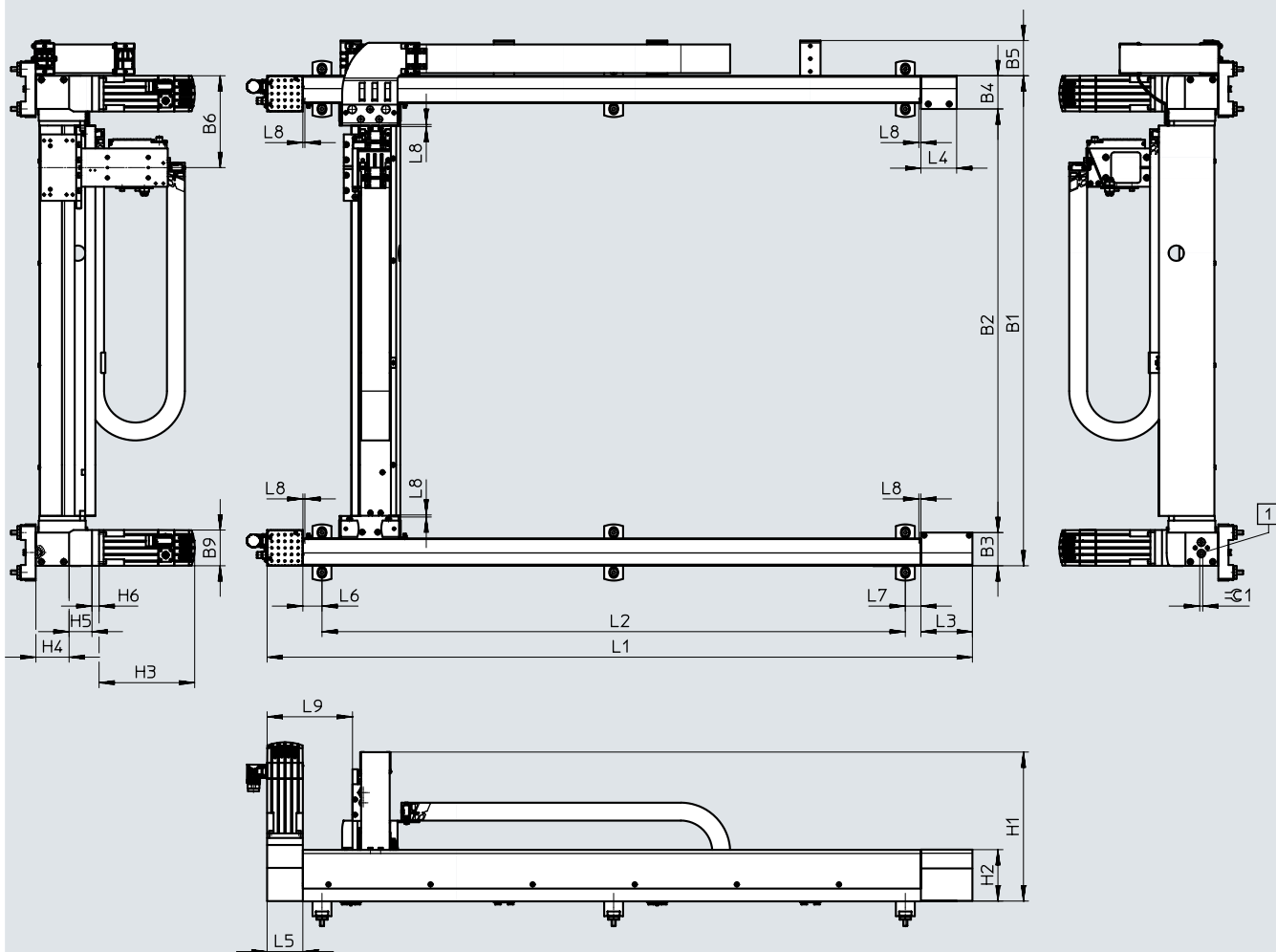

[1] Screw for toothed belt tension

L8 Safety distance per side

EXCH-40-...-B – Motor mounting position underneath

EXCH-40-... – Motor interface

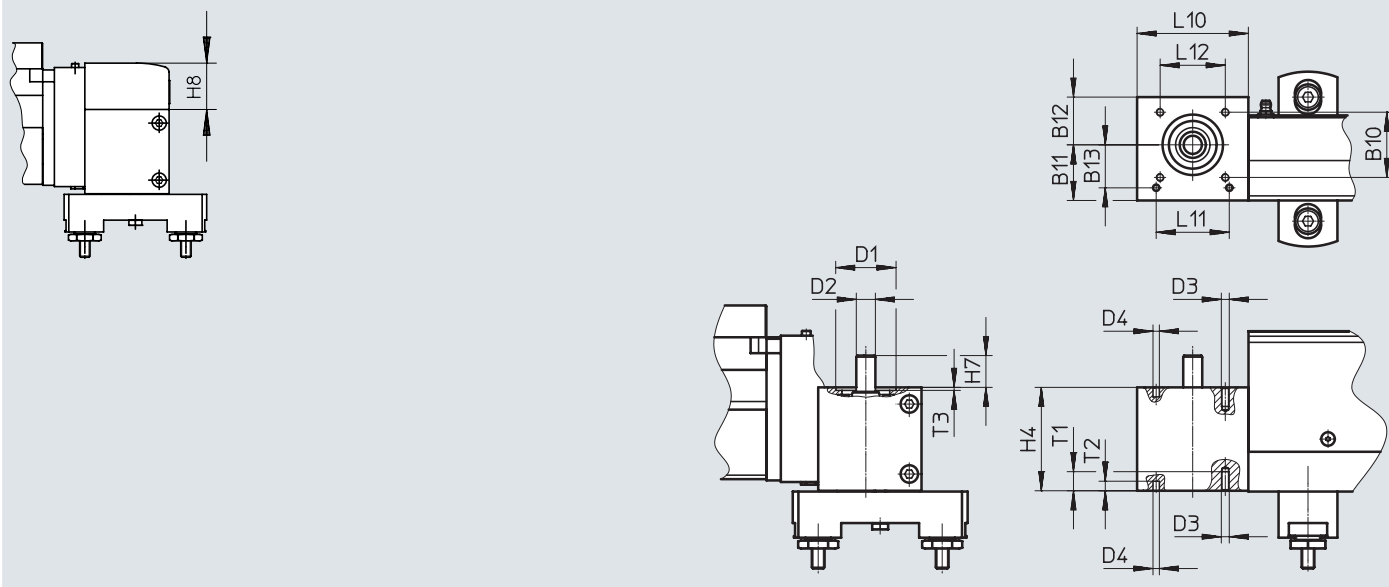

Datasheet

Dimensions

Download CAD data → www.festo.com

EXCH-40-... – Slide

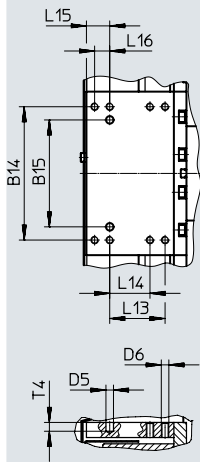

Type	B3	B4	B5	B6	B10	B11	B12	B13	B14	B15
								±0.05	±0.1	±0.03
EXCH-...	65	65	69	179.9	41	35	30	27	106	85

Type	D1	D2	D3	D4	D5	D6	H1	H2	H4	H7
	∅	∅		∅	∅					
	H7	h6		H7	H7					
EXCH-...	38	12	M5	4	6	M6	Approx. 293	100.8	65	20

Type	H8	L3	L4	L5	L6	L7	L8	L9	L10	L11
										±0.03
EXCH-...	100.3	101	70	70	37.5	30.5	4	167.2	70	46

Type	L12	L13	L14	L15	L16	T1	T2	T3	T4	≈G1
		±0.1	±0.1		±0.1					
EXCH-...	41	44	32	18.5	12	12	6	1.9	7	6

Stroke-dependent dimensions

Stroke of the X-axis	L1	L2	Stroke of the Y-axis	B1	B2
500	882	643	400	760	630
750	1132	893	500	860	730
1000	1382	1143	750	1100	980
1500	1882	1643	1000	1360	1230
200 ... 2000	382+stroke	→ Page 17	200 ... 1000	360+stroke	230+stroke

**Note**

Depending on the stroke of the X-axis, a different number of profile mountings is required. The distance between the profile mountings must always be the same (→ page 17).

The tension of the toothed belt must be set before commissioning. The tools required to do this (e.g. frequency meter) are not included in the scope of delivery.

Datasheet

Dimensions

Download CAD data → www.festo.com

EXCH-60-...-T – Motor mounting position on top

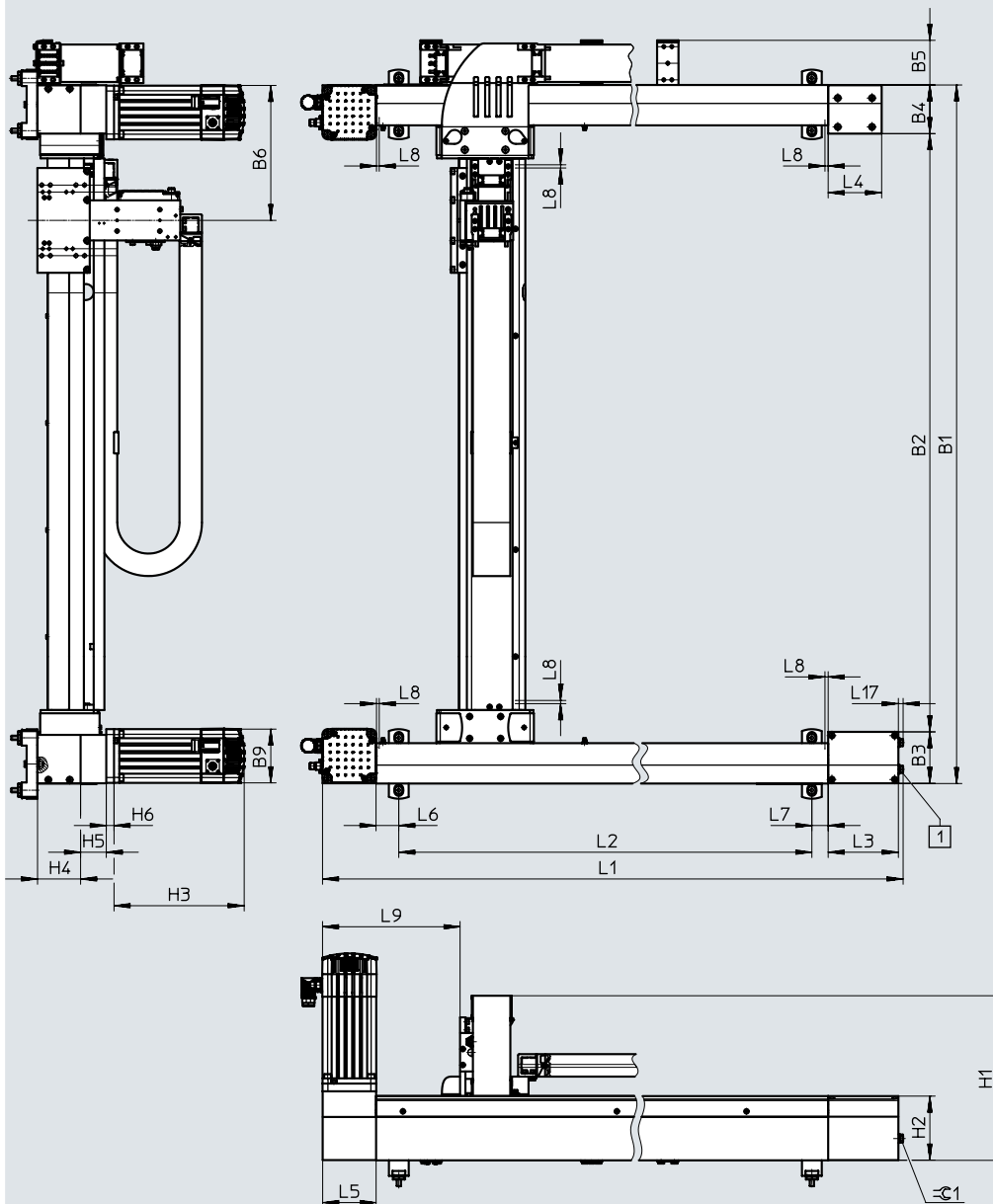

[1] Screw for toothed belt tension

L8 Safety distance per side

Datasheet

Type	B3	B4	B5	B6	H1
EXCH-...	96.6	91	83.5	253.3	Approx. 310

Type	H2	H4	L3	L4	L5
EXCH-...	120.1	80.6	131.2	100	100

Type	L6	L7	L8	L9	L17	≅G1
EXCH-...	42.5	30.5	6	257	8.9	13

Stroke-dependent dimensions					
Stroke of the X-axis	L1	L2	Stroke of the Y-axis	B1	B2
750	1393	1079.9	500	1007	819
1000	1643	1329.9	750	1257	1069
1500	2143	1829.9	1000	1507	1319
2000	2643	2329.9	1250	1757	1569
500 ... 2500	643 + stroke	→ Page 17	1500	2007	1819
			500 ... 1500	507 + stroke	319 + stroke

**Note**

Depending on the stroke of the X-axis, a different number of profile mountings is required. The distance between the profile mountings must always be the same (→ page 17).

The tension of the toothed belt must be set before commissioning. The tools required to do this (e.g. frequency meter) are not included in the scope of delivery.

Datasheet

Dimensions

Download CAD data → www.festo.com

EXCH-60-...-B – Motor mounting position underneath

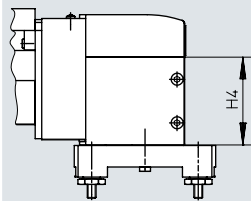

EXCH-60-... – Motor interface

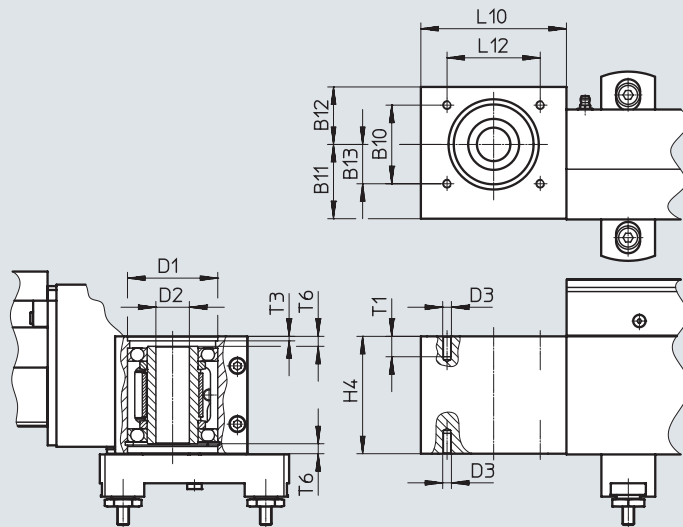

EXCH-60-... – Slide

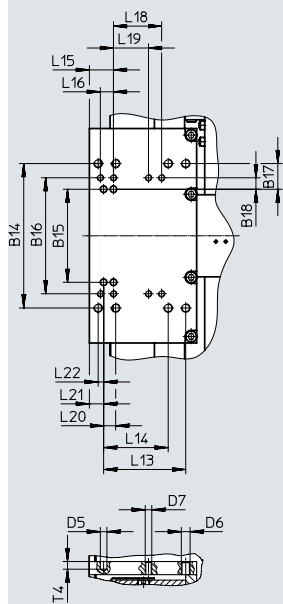

Type	B10	B11	B12	B13	B14	B15	B16	B17	B18	D1
	±0.1			±0.05	±0.1	±0.03	±0.1	±0.1	±0.1	∅ H7
EXCH-...	54	51	39.5	27	132	85	106	23.5	10.5	62

Type	D2	D3	D5	D6	D7	H4	H8	L10	L12	L13	L14
	∅ H7		∅ H7						±0.1	±0.1	±0.1
EXCH-...	23	M6	6	M8	M6	80.6	119.6	100	64	75	59

Type	L15	L16	L18	L19	L20	L21	L22	T1	T3	T4	T6
		±0.1	±0.1	±0.1	±0.1						
EXCH-...	22	12	44	32	11	13	5	14	3.1	7	6.9

Datasheet

Dimensions

Download CAD data → www.festo.com

Adjusting kit EADC

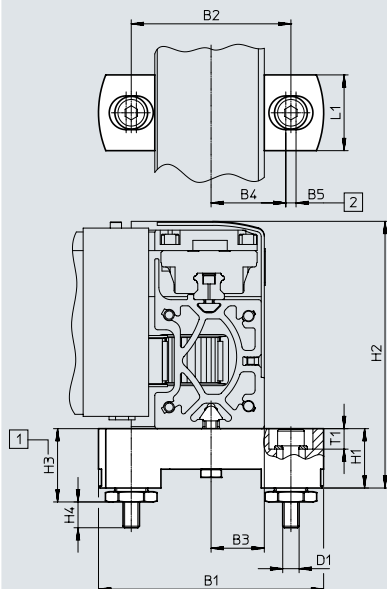

[1] Adjustable

[2] Width of elongated hole

Height differences of up to 5 mm can be compensated using the adjusting kit.

Can be ordered via:

Modular product system → page 24

or Accessories → page 26

For size	B1	B2	B3	B4 ±0.2	B5	D1	H1	H2	H3		H4 max.	L1	T1
									min.	max.			
40	110	78	26	36.5	5	M8	29	129.8	34.8	39.8	14	37	10
60	130	98	36.5	46.5	5	M8	29	149.1	34.8	39.8	14	37	10

Mounting kit

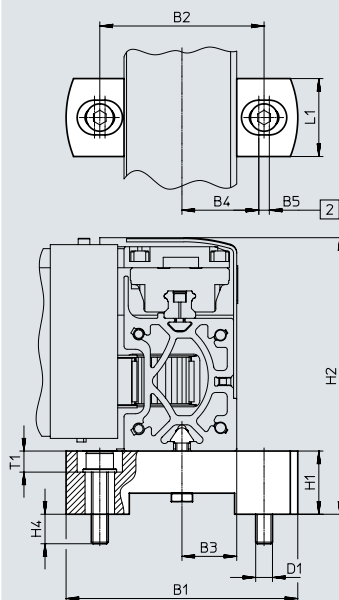

[2] Width of elongated hole

No compensation is possible using the mounting kit.

Can be ordered via:

Modular product system → page 24

or Accessories → page 26

For size	B1	B2	B3	B4 ±0.2	B5	D1	H1 +0.2	H2	H4 max.	L1	T1
60	130	98	36.5	46.5	5	M8	30	150.1	14	37	10

Ordering data – Modular product system

Ordering table					
Size	40	60	Conditions	Code	Enter code
Module no.	1923050	1939785			
Product type	EXCH series H			EXCH	EXCH
Size	40	60		-...	
Stroke of the X-axis [mm]	200 ... 2000	500 ... 2500			
Stroke of the Y-axis [mm]	200 ... 1000	500 ... 1500			
Guide	Recirculating ball bearing guide			-KF	-KF
Motor type	Without motor			-W	-W
Motor attachment position	Underneath			-B	
	On top			-T	
Energy chain connection side	To the left			-L	-L
Attachment components	None			-TO	-TO
Cable length	None			-	
	With cable length 5 m			-5K	
	With cable length 10 m			-10K	
Mounting kit	With adjusting kit				
	With mounting kit			-P	
Document language	German			-DE	
	English			-EN	
	Spanish			-ES	
	French			-FR	
	Italian			-IT	
	Russian			-RU	
	Chinese			-ZH	

 **Note**

In combination with characteristic W (without motor), the planar surface gantry EXCH is delivered without coupling housing and without coupling.

Accessories

-  - Note

Depending on the combination of motor and drive, it may not be possible to reach the maximum feed force of the drive.

Third-party motors that have an overly high driving torque may damage the linear gantry. When selecting the motors, please observe the limits specified in the technical data.

Permissible axis/motor combinations with axial kit

Datasheets → Internet: eamm-a

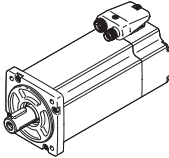
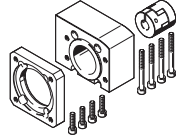
Motor/gear unit ¹⁾	Axial kit	
	 <ul style="list-style-type: none"> • Kits for third-party motors → Internet: eamm-a 	
Type	Part no.	Type
EXCH-40		
With servo motor		
EMMT-AS-80-...	8164654	EAMM-A-X48-80P
EXCH-60		
With servo motor		
EMMT-AS-100-...	8164656	EAMM-A-X62-100A
EMMT-AS-150-...	8164657	EAMM-A-X62-150A

1) The input torque must not exceed the max. permissible transferable torque of the axial kit.

Ordering data

Coupling	For axial kit	Part no.	Type
	EAMM-A-X48-80P	551005	EAMC-42-50-12-19
	EAMM-A-X62-100A	558003	EAMD-56-46-19-23X27
	EAMM-A-X62-150A	558005	EAMD-56-46-24-23X27

Accessories

Sensor mounting EAPR

For proximity switch
SIES-V3B and SIES-Q8B
(for sensing the slide position on the X-axis)

Material:
Switch lug: Steel
Sensor bracket: Wrought aluminium alloy
RoHS-compliant

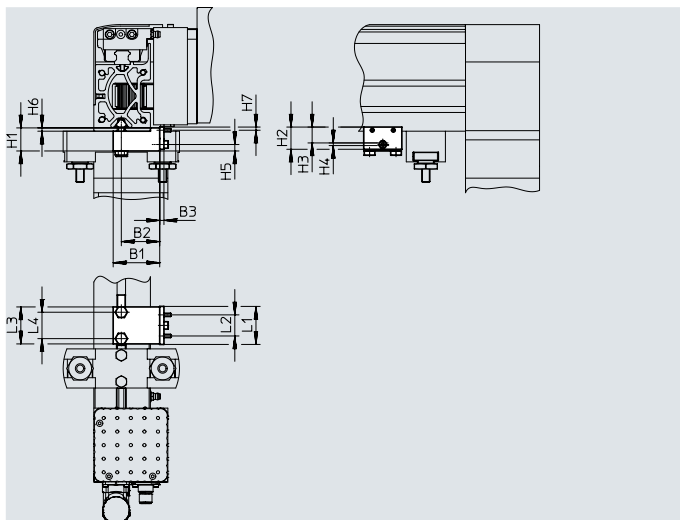
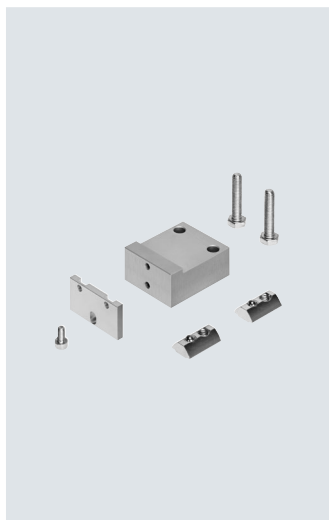

Dimensions and ordering data

For size	B1	B2	B3	H1	H2	H3 ±0.1	H4	H5	H6 -0.1	H7 -0.2
40	44	36.3	4	21.8	21	15	2.5	6.1	3.1	3
60	54	46.3	4	21	21	15	2.5	5.3	2.3	3

For size	L1	L2	L3	L4	Weight [g]	Part no.	Type
40	36	20	35	25	120	2536353	EAPR-E12-40
60	36	20	35	25	150	2478805	EAPR-E12-60

Ordering data

For size	Description	Part no.	Type
----------	-------------	----------	------

Adjusting kit EADC

	40	For mounting and aligning the planar surface gantry. The kit is height-adjustable	8029165	EADC-E12-40
	60		8029166	EADC-E12-60

Mounting kit EAHM

	40	For mounting the planar surface gantry. The kit is not height-adjustable	3489340	EAHM-E12-K-40
	60		3489318	EAHM-E12-K-60

Accessories

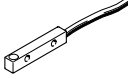
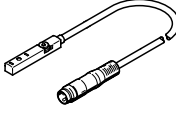
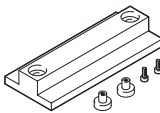
Designation	Description	Cable length [m]	Part no.	Type
Proximity switches for sensing the position of the slide on the X-axis - To be used in combination with sensor mounting EAPR-E12				
	<ul style="list-style-type: none"> For EXCH-40, EXCH-60 	PNP, N/O contact	–	150491 SIES-V3B-PS-S-L
	<ul style="list-style-type: none"> For EXCH-40, EXCH-60 	PNP, N/C contact	–	174552 SIES-Q8B-PO-K-L
Proximity switch (inductive) for sensing the position of the slide on the Y-axis				
	Cable with plug <ul style="list-style-type: none"> For EXCH-40, EXCH-60 For DC voltage 	PNP, N/C contact	0.3	551392 SIES-8M-PO-24V-K-0.3-M8D
		PNP, N/O contact	0.3	551387 SIES-8M-PS-24V-K-0.3-M8D
Ordering data				
	For size	Description	Part no.	Type
Adjusting tool EADT				
	40, 60	For aligning and checking the flatness of the planar surface gantry	3197697	EADT-W-E12