

# SMAT-8M position transmitter

FESTO

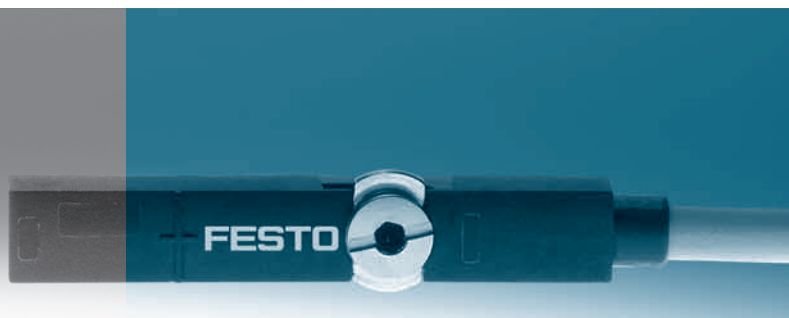

## Small and flat

**A position transmitter the size of a proximity sensor: the SMAT-8M. Designed for all applications with restricted installation space. Its compact design opens up new areas of application, especially for compact cylinders and grippers. It provides positional feedback in the form of an analogue voltage signal via the cylinder piston.**

### High performance

Thanks to its compact design, the SMAT-8M can be securely installed flush in the slot of grippers and compact cylinders. Simply insert in the slot and fasten via the 1.5 mm internal hex. The reduced weight is especially impressive for dynamic applications. Its detection range of up to 40 mm guarantees a free choice of switching points for applications such as gripping, clamping, pressing, etc.

### Flexible application

The SMAT-8M fits in almost all Festo T-slot drives – and can be fitted in both directions. Thanks to the connected load of 0 - 10 V, the position transmitter with analogue inputs can be connected without the use of accessories.

### Reliable function

If the function range is exceeded, integrated out-of-range detection ensures that the information is reliable. The data is transmitted via analogue signal and LED. The contactless measuring principle ensures wear-resistant sensing.

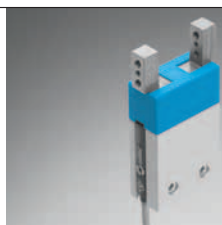

Compact design

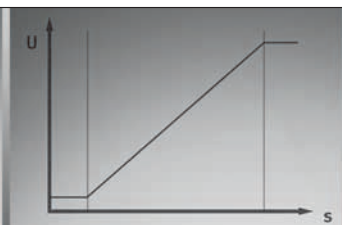

Analogue signal



Simple mounting

319.2.PSI →

Product Short Information

# SMAT-8M position transmitter

## Typical applications

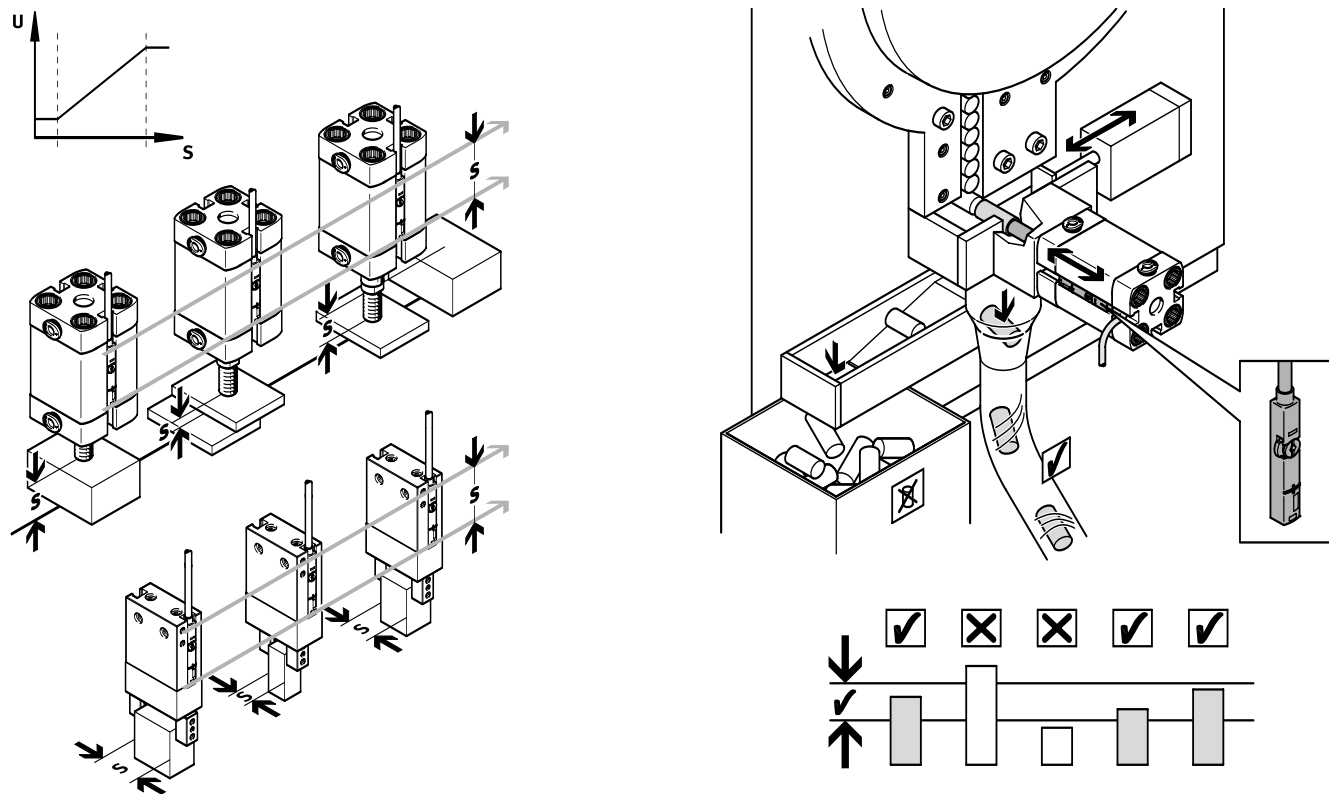

## Areas of application

The compact design of the position transmitter opens up new areas of application for compact cylinders and grippers.



Technical data	
Type	SMAT-8M-U-E-0.3-M8D
Power supply	15 - 30 V
Measuring principle	Contactless, magnetic
Reproducibility	Type. $\pm 0,1$ mm, on grippers $\pm 0,025$ mm
Measuring range	Up to 40 mm, depending on drive
Output	0 - 10 V
Connection	Cable 0.3 m long with M8 plug 4-pin
Protection class	IP 65 and 68
Certifications	UL, C-Tick
Part number	Type code
553744	SMAT-8M-U-E-0.3-M8D

## Festo AG & Co. KG

Ruiter Strasse 82  
73734 Esslingen  
www.festo.com  
Tel. +49 711 347-0  
Fax +49 711 347-2144  
service\_international@festo.com