

Terminal CPX

Electrical interface CPX-CTEL-2-M12-5POL-LK

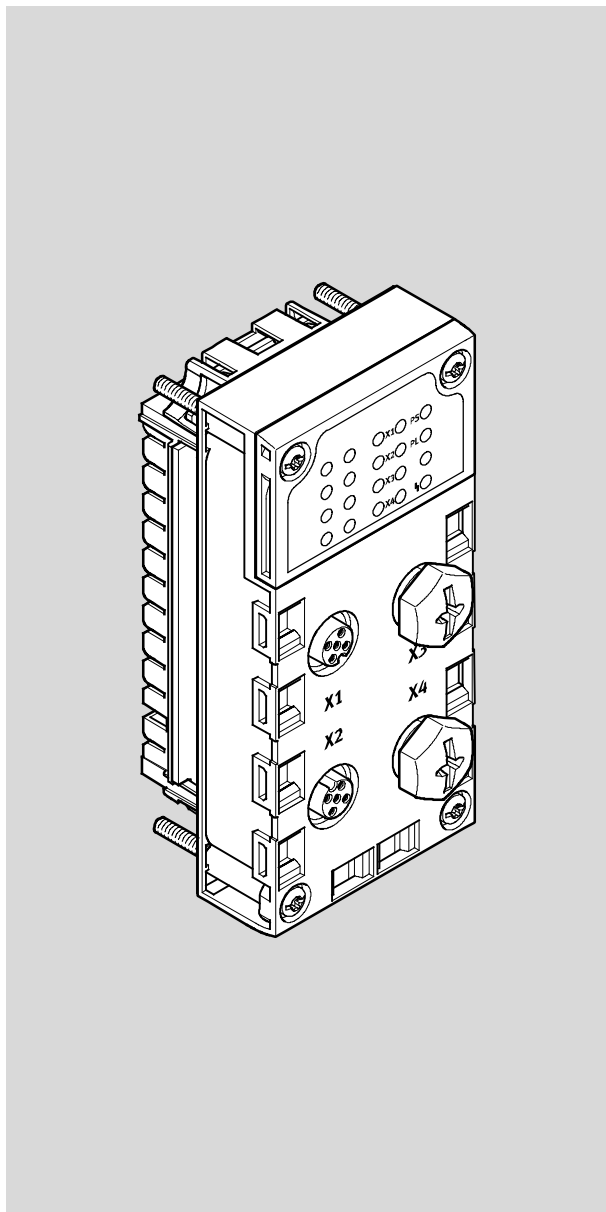

FESTO

Description
Electronics

8034116
1405NH
[8034124]

Translation of the original instructions

P.BE-CPX-CTEL-LK-EN

IO-Link® and TORX® are registered trademarks of the respective trademark owners in certain countries.

Identification of hazards and instructions on how to prevent them:



Warning

Hazards that can cause death or serious injuries.



Caution

Hazards that can cause minor injuries or serious material damage.

Other symbols:



Note

Material damage or loss of function.



Recommendations, tips, references to other documentation.



Essential or useful accessories.



Information on environmentally sound usage.

Text designations:

- Activities that may be carried out in any order.
- 1. Activities that should be carried out in the order stated.
- General lists.

Table of contents – Electrical interface CPX-CTEL-2-M12-5POL-LK

1	Safety and requirements for product use	6
1.1	Safety	6
1.1.1	General safety information	6
1.1.2	Intended use	6
1.2	Requirements for product use	8
1.2.1	Technical prerequisites	8
1.2.2	Qualification of the specialized personnel (requirements for the personnel) ...	8
1.2.3	Range of application and approval certificates	8
2	Overview	9
2.1	Product overview	9
2.2	IO-Link	10
2.2.1	Interfaces	10
2.2.2	Pin allocation	11
2.3	LED indicators	11
2.3.1	Overview of LED indicators	11
2.3.2	Behaviour and significance of the LED indicators	12
2.4	Addresses	13
2.4.1	I/O configuration presetting	13
2.4.2	Setting of the I/O configuration presetting	13
3	Mounting and installation	15
3.1	General instructions	15
3.2	Mounting/dismounting	16
3.3	Connecting cables	17
3.4	Connection of devices	18
3.5	Connecting the power supply	19
3.5.1	Power supply	19
3.5.2	Determining the current consumption	20
3.6	Connection with the host system	21
3.7	Ensuring degree of protection IP65/67	21
4	Commissioning	22
4.1	Configuration	22
4.1.1	Establish address space	22
4.1.2	Address assignment in the CPX system	23
4.2	Procedure for commissioning	24
4.3	Prepare commissioning	24
4.3.1	Check the module and the connected devices	24

4.4	Behaviour in case of malfunctions in operation	25
4.5	Notes on operation	25
4.6	Parameters	26
4.6.1	Overview of module parameters	26
4.6.2	Parameter “Monitoring U_{OUT}/U_{VAL} ”	27
4.6.3	Parameter “Behaviour after port short circuit”	27
4.6.4	Parameter “port settings”	27
4.7	Commissioning with the operator unit (CPX-MMI)	28
4.7.1	Menu commands of the module on the operator unit (CPX-MMI)	28
4.7.2	Observe signal statuses (monitoring)	29
4.7.3	Parameterisation with the operator unit (CPX-MMI)	29
4.8	Commissioning with the Festo Maintenance Tool software (CPX-FMT)	30
5	Diagnostics and error handling	31
5.1	Summary of diagnostics options	31
5.2	Diagnostics/error messages	32
5.2.1	Priorities of the diagnostic/error messages	32
5.2.2	Diagnostic/error messages by CPX error numbers	33
5.3	Diagnostics via LED indicators	34
5.4	Diagnostics via the CPX bus node	35
5.4.1	Status bits of the CPX terminal	35
5.4.2	I/O diagnostic interface and diagnostic memory	35
5.5	Diagnostics with the operator unit (CPX-MMI)	36
5.6	Diagnostics with the Festo Maintenance Tool (CPX-FMT)	37
5.7	Behaviour after lost connection to the device	38
5.8	Behaviour in the event of power supply errors	39
A	Technical appendix	40
A.1	Technical data	40
A.2	Event codes	43
A.3	Accessories	44
B	Glossary	45
B.1	List of abbreviations	45

Notes on this documentation

This documentation is intended to help you safely work with the module. It includes safety instructions that must be observed.



An overview of the structure of the User Documentation for the CPX terminal can be found in the CPX system description (P.BE-CPX-SYS-...).

Product identification, versions



This documentation refers to the following version:

- Revision R2



Note

- With newer firmware versions, check whether there is a newer version of this description available (➔ www.festo.com).

Service

Please consult your regional Festo contact if you have any technical problems.

1 Safety and requirements for product use

1.1 Safety

1.1.1 General safety information

- Observe the general safety information in the corresponding chapters.



Special safety and danger warnings are written directly before the action instruction.



Note

Damage to the product from incorrect handling.

- Switch off the supply voltage before performing mounting and installation work. Switch on supply voltage only when the mounting and installation work is completely finished.
- Never unplug or plug in a product when powered!
- Observe the handling specifications for electrostatically sensitive devices.



1.1.2 Intended use

The module described in this document provides 2 outward interfaces to connect devices with IO-Link interface.

The module is intended for use in an industrial environment. Outside of industrial environments, e.g. in commercial and mixed-residential areas, actions to suppress interference may have to be taken.

The module is intended exclusively for use in CPX terminals from Festo for installation in machines or automated systems and may be used only in the following ways:

- in perfect technical condition
- in original status without unauthorised modifications, except for the adaptations described in this documentation
- within the limits of the product defined through the technical data (➔ A.1 Technical data).



Warning

Electric shock

Injury to people, damage to the machine and system

- For the electrical power supply, use only PELV circuits in accordance with IEC 60204-1 (Protective Extra-Low Voltage, PELV).
- Observe the general requirements of IEC 60204-1 for PELV circuits.
- Use only voltage sources that guarantee a reliable electrical disconnection of operating and load voltage in accordance with IEC 60204-1.
- Always connect all circuits for operating and load voltage supply $U_{EL/SEN}$, U_{VAL} and U_{OUT} .

Through the usage of PELV circuits, protection from electric shock (protection from direct and indirect contact) in accordance with IEC 60204-1 is ensured (Electrical equipment of machines, General requirements).



Observe the information on power supply and the earthing measures to be carried out provided in the CPX system description (P.BE-CPX-SYS-...).



Note

In the event of damage caused by unauthorised manipulation or other than intended use, the warranty is invalidated and the manufacturer is not liable for damages.

1.2 Requirements for product use

- Make this documentation available to the design engineer, installer and personnel responsible for commissioning the machine or system in which this product is used.
- Make sure that the specifications of the documentation are always complied with. Consider also the documentation for other components and modules (e.g. CPX system description P.BE-CPX-SYS-...).
- Take into consideration the legal regulations applicable for the destination as well as
 - regulations and standards
 - regulations of the testing organizations and insurers
 - national specifications.

1.2.1 Technical prerequisites

General notes for the correct and safe use of the product, which must be observed at all times:

- Comply with the connection and environmental conditions specified in the technical data of the product (→ A.1 Technical data) and of all connected components.
Only compliance with the limit values or load limits permits operation of the product in accordance with the relevant safety regulations.
- Observe the notes and warnings in this documentation.

1.2.2 Qualification of the specialized personnel (requirements for the personnel)

This description is directed exclusively to technicians trained in control and automation technology, who are experienced in:

- installation and operation of electrical control systems
- the applicable regulations for operating safety-engineering systems
- the applicable regulations for accident protection and operational reliability
- the documentation for the product.

1.2.3 Range of application and approval certificates

Standards and test values, which the product must comply with and fulfil, can be found in the section “Technical data” (→ A.1 Technical data).

The product-relevant EC directives can be found in the declaration of conformity.



Certificates and the declaration of conformity for this product are found on the Internet page of Festo (→ www.festo.com).

2 Overview

2.1 Product overview

Festo can assist you in solving your automation task at the machine level with the aid of valve terminals and I/O modules.

The electrical interface CPX-CTEL-2-M12-5POL-LK permits connection of devices with IO-Link interface (devices) to a CPX system.

Up to 2 devices per module can be integrated into the CPX system.

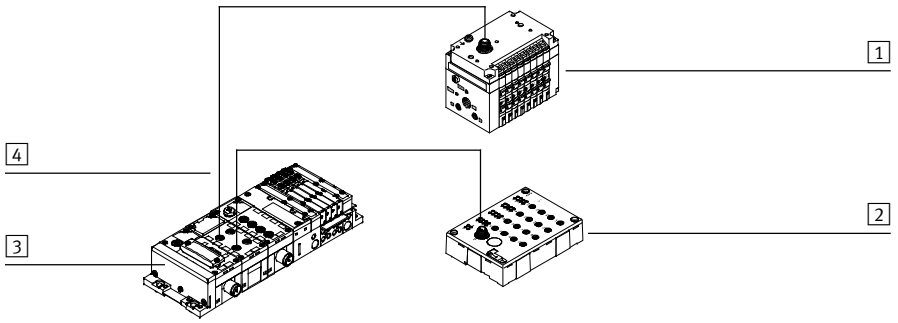

- 1 Valve terminal with IO-Link
- 2 Input module with IO-Link
- 3 CPX terminal with electrical interface CPX-CTEL-2-M12-5POL-LK

- 4 Connecting cables

Fig. 2.1

2.2 IO-Link

The IO-Link network system serves to exchange serial data from decentralised function modules (devices) at the field level.

The electrical interface CPX-CTEL-2-M12-5POL-LK has 2 interfaces (ports) that, with few limitations, support connection of IO-Link devices.

The limitations compared to the IO-Link standard are:

- the SIO mode is not supported.
- the process data length of the inputs and outputs is limited to 32 bytes (2 x 16) each.
- the driver strength on the C/Q line is limited to 250 mA.

The connection type corresponds to a start topology, that means, only 1 device can be connected to each port.

2.2.1 Interfaces

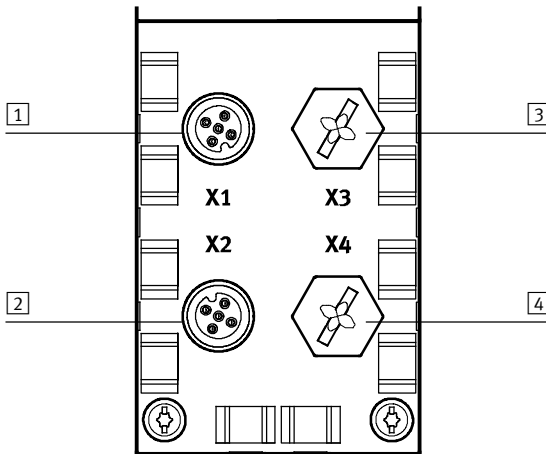

1 Port 1 (X1)

2 Port 2 (X2)

1) Sealed with protective cap

3 X3 (without function)¹⁾

4 X4 (without function)¹⁾

Fig. 2.2



Note

The ports X3 and X4 are without function and sealed at the factory with a protective cap.

2.2.2 Pin allocation

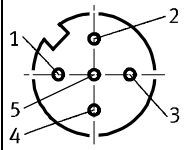
Top view	Pin	Allocation	Function
	1	24 V $U_{EL/SEN}$	Operating voltage supply PS (Power System)
	2	24 V $U_{VAL/OUT}$	Load voltage supply PL (Power Load)
	3	0 V $U_{EL/SEN}$	Operating voltage supply PS (Power System)
	4	C/Q	Communication C/Q
	5	0 V $U_{VAL/OUT}$	Load voltage supply PL (Power Load)

Tab. 2.1

2.3 LED indicators

The module is equipped with seven LED indicators, with whose help the current status (operating status) of the module and the devices connected to it can be determined.

The LED indicators X3 and X4 are without function, since the corresponding ports are not used.

2.3.1 Overview of LED indicators

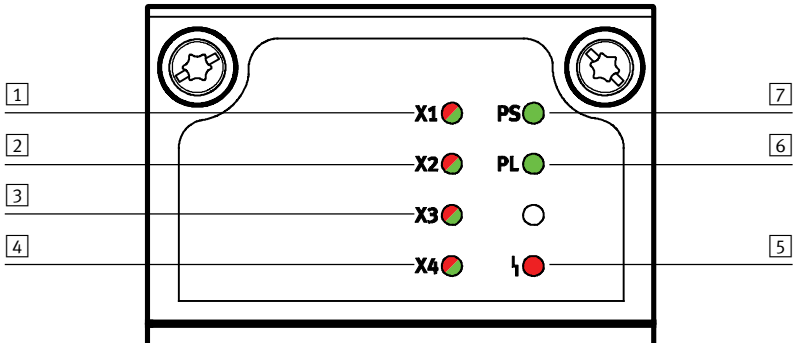

- | | |
|---|--|
| 1 X1 (status port X1) | 5 Module fault |
| 2 X2 (status port X2) | 6 PL (load voltage supply) |
| 3 X3 (without function) | 7 PS (power supply) |
| 4 X4 (without function) | |

Fig. 2.3

2.3.2 Behaviour and significance of the LED indicators

LED	Behaviour	Significance
PS	Off	Power supply (PS) is not connected or has fallen below the minimum supply voltage for the electronics (module is not active).
	Illuminates green	Power supply (PS) is connected (supply to all ports is OK).
	Flashes green	Undervoltage in the power supply (PS)
PL	Off	Several causes are possible: <ul style="list-style-type: none"> – load voltage supply (PL) is deactivated by parameter for both ports. – no devices at all are connected.
	Illuminates green	Load voltage supply (PL) is connected to the ports with activated PL supply and is OK.
	Flashes green	Undervoltage detected in load voltage supply (PL). Several causes are possible: <ul style="list-style-type: none"> – load voltage supply (PL) is not applied or is too low¹⁾. – at least one connected device reports an undervoltage in the load voltage supply (PL)²⁾.
I	Off	CPX system-internal communication OK.
	Lights up red	Several causes are possible: <ul style="list-style-type: none"> – CPX system starts momentarily, display then turns off. – general error.
X1 ... X2	Off	No connection to a device.
	Lights up green	Device connected, communication OK
	Flashes green	Several causes are possible: <ul style="list-style-type: none"> – connection is established to the device, diagnostics running – I/O length of the recognised device is too large.
	Lights up red	Error in communication between module and device.
	LEDs X1 and X2 light up red	Short circuit detected in C/Q line at X1 or X2 erkannt ³⁾ (both ports are switched off).

1) Only if PL supply is activated for at least 1 port.

2) Also if PL supply is deactivated for all ports.

3) Indirect short circuit detection through temperature monitoring, returns automatically.

Tab. 2.2



Since all connected devices use the LED indicator PL, indicator of an error has priority over an indicator “OK” (LED illuminated green).

The port at which the error occurred can be determined through the FMT or MMI of the diagnostic messages. Information on error elimination
(→ 5.2.2 Diagnostic/error messages by CPX error numbers).

2.4 Addresses

The module can make available a total of up to 16 bytes for inputs and 16 bytes for outputs per port. The precise quantity of the I/O bytes made available depends on the selected configuration presetting.

2.4.1 I/O configuration presetting

The address space that the module makes available and assigns accordingly in the CPX system can be configured according to various presettings (→ Tab. 2.3).

These presettings correspond to the selection options that are supported within the configuration files for the respective host system (→ 3.6 Connection with the host system).

I/O length of the module	Inputs per port	Outputs per port
8 bytes (64 bits)	4 bytes (32 bits)	4 bytes (32 bits)
16 bytes (128 bits)	8 bytes (64 bits)	8 bytes (64 bits)
24 bytes (192 bits)	12 bytes (96 bits)	12 bytes (96 bits)
32 bytes (256 bits)	16 bytes (128 bits)	16 bytes (128 bits)

Tab. 2.3

Which of these configuration presettings the module uses can be determined manually through the user.

2.4.2 Setting of the I/O configuration presetting

Setting is made via DIL switches on the left side of the module, directly below the housing cover (→ Fig. 2.4). These are only accessible if the module is removed from the interlinking block (→ 3.2 Mounting/dismounting).

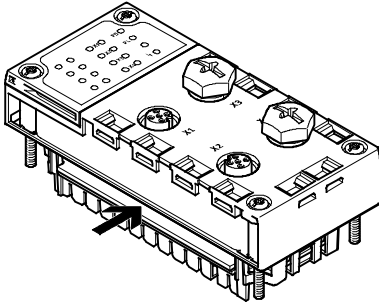
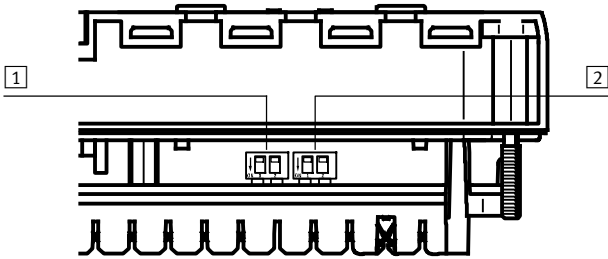

Fig. 2.4

DIL switches



1 DIL switch group 1

2 DIL switch group 2 (without function)

Fig. 2.5



The I/O configuration presetting for the module is determined with the DIL switches 1.1 and 1.2 (→ Tab. 2.4).

This setting is applicable for both ports in common (maximal 16 bytes per port).

The DIL switch group 2 has no function with this product.

DIL switch 1	S1.1	S1.2	Function
	OFF	OFF	4 bytes I/O
	OFF	ON	8 bytes I/O
	ON	OFF	12 bytes I/O
	ON	ON	16 bytes I/O

Tab. 2.4

3 Mounting and installation

3.1 General instructions



Warning

Personal injury and material damage

Uncontrolled movements of the connected actuator technology and uncontrollable movements of loose tubing.

- Before carrying out mounting, installation and maintenance work, switch off the following:
 - compressed air supply
 - operating voltage supply for the electronics/sensors
 - load voltage supply for the outputs/valves.



Caution

Electrostatically sensitive devices!

- Do not touch any components
- Observe the handling specifications for electrostatically sensitive devices. They will help you avoid damage to the electronics.



Note

- Handle all modules and components carefully.
- Comply with the specified torques.



Information about mounting of the CPX terminal can be found in the CPX system description (P.BE-CPX-SYS-...).

3.2 Mounting/dismounting

The module is designed for mounting in a CPX interlinking block (→ Fig. 3.1).



Warning

Mounting /dismounting of the module must always take place in a de-energised status.

- Disconnect the corresponding CPX terminal completely from the related power supply or switch it off.



Note

The module does not have a separate connection block, but is designed as a complete unit.



Before the module is mounted, it makes sense to set or check the desired configuration with the help of the DIL switches, since they can no longer be reached after mounting (→ 2.4.2 Setting of the I/O configuration presetting).

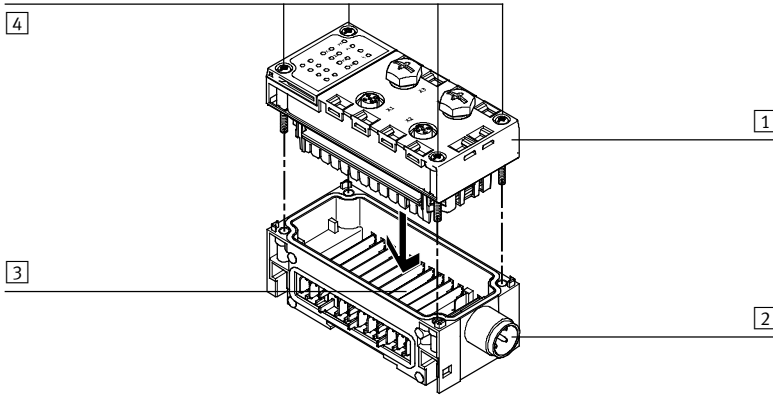

1 Module

2 Interlinking block¹⁾

3 Contact rails

4 Screws

1) Here with additional power supply as an example

Fig. 3.1

Mounting

Mount the module as follows:

1. Check seal and sealing surface.
2. Insert module into the interlinking block. Make sure that the corresponding slots with the contacts on the bottom of the module lie above the contact rails.
3. Push the module carefully and without tilting into the interlinking block up to the stop.
4. Screws should only be tightened by hand. Screws must be set so that the existing self-cutting threads can be used.
5. Tighten the screws with a TORX screwdriver, size T10 with 0.9 ... 1.1 Nm.

Dismantling

Dismantle the module as follows:

1. Loosen screws with a TORX screwdriver, size T10.
2. Pull module carefully and without tilting away from the contact rails of the interlinking block.

3.3 Connecting cables



Note

Malfunction due to impermissible cabling.

- If possible, use only specified connecting cables from Festo to connect the devices to the module (→ www.festo.com/catalogue).
- Observe the maximum length of 20 m for the connecting cables used to connect the devices.

You will then avoid errors in data exchange between the module and the connected devices.



Replacement of devices during operation (tool change mode).

The interface of the connecting cable must be designed so that, when creating the connection, the contacts of the power supply (PS) are energised first.

Otherwise, a short circuit might be reported temporarily through the voltage present on the C/Q cable when the connection is created.

3.4 Connection of devices

A total of up to 2 IO-Link devices can be connected to the module. These are connected to the module through specified connecting cables (→ 3.3 Connecting cables).



If an error occurs on several devices simultaneously, only the diagnostic or error message of the device with the highest priority is passed on (→ 5.2.1 Priorities of the diagnostic/error messages).

After this error is eliminated, the error with the next lowest priority is displayed. The priority of the connected devices results from the number of the used port (X1 or X2). The device at X1 has the highest, the device at X2 the lowest priority in representing a diagnostic or error message.

With use in a CPX terminal of more than one of the modules described here, the module that is mounted closer to the CPX bus node has the higher priority.



The result of this is that devices with process-critical functions must be connected to the port with the higher priority.

Connect devices:

1. Connect devices with the connecting cables to the module corresponding to their priority (see above).
2. Tightly screw the plug of the connecting cable to the socket of the module. In this way, the electrical contact is guaranteed.
3. With the inscription labels (type IBS 6x10 or IBS 9x20), mark the port to which the device is connected. In this way you can avoid confusion during later repair and maintenance work.

3.5 Connecting the power supply

Take the following aspects into consideration when installing a CPX system with the module described here:

- power supply (→ 3.5.1 Power supply)
- current consumption (→ 3.5.2 Determining the current consumption)
- formation of voltage zones (→ CPX system description P.BE-CPX-SYS-...).



Note

- Observe the notes on earthing the devices in the description for the respective device.

Recommendation:

- When implementing an emergency-off function, guide the load voltage of the corresponding actuator technology separately.



Note

- Check whether a pressure switch-off on the machine or system is also necessary in case of emergency off.

3.5.1 Power supply

The CPX terminal has 3 different conductors:

- $U_{EL/SEN}$: Power supply (PS) for internal electronics of the module and connected devices
- U_{OUT} : Load voltage supply for digital output modules
- U_{VAL} : Load voltage supply (PL) for valve terminals, output modules or other consumers.



The load voltage supply U_{OUT} is not used by the module described here. Additional information on power supply and formation of voltage zones (→ CPX system description P.BE-CPX-SYS-...).



Note

Malfunctions due to insufficient power supply.

- Supply of the load voltage supply U_{VAL} must be sufficiently dimensioned to be able to supply the connected actuators.
- Observe that, dependent on the respective length of the connecting cable and current consumption of the connected device, a voltage drop results between the module and device.

Therefore, when connecting cables > 5 m are used, the operating voltage supply $U_{EL/SEN}$ should not be fallen below by more than 10 %.

- The total current requirement of the CPX terminal and the connected devices as well as the limit values for the maximum current intensities must be taken into account in the design of the power supply (→ 3.5.2 Determining the current consumption).

3.5.2 Determining the current consumption

The current consumption of the module depends on the number and type of connected devices.



Recommendation:

- Use a regulated power supply
- When selecting the power supply unit, check whether it has sufficient output. Calculate the total current consumption, if necessary.

Calculation:

- Use the following table to calculate the total current consumption (→ Tab. 3.1).
- Refer to the corresponding technical data for the current consumption of the devices.



Note

- Select a power supply unit which provides sufficient power for later extensions.
- Observe the notes regarding selection of the power supply unit in the CPX system description (P.BE-CPX-SYS-...).



- If output modules with a separate load voltage connection are used, take into account the corresponding current consumption when selecting a power supply unit.

Current consumption from $U_{EL/SEN}$ of the CPX terminal		
Current consumption of internal electronics of the module		approx. 0.06 A
Current consumption of device internal electronics at X1 ¹⁾	_____ A	
Current consumption of sensors at X1 ¹⁾	+ _____ A	
Sum of current consumption at X1 (max. 1.6 A)	= _____ A	+ _____ A
Current consumption of device internal electronics at X2 ¹⁾	_____ A	
Current consumption of sensors at X2 ¹⁾	+ _____ A	
Sum of current consumption at X2 (max. 1.6 A)	= _____ A	+ _____ A
Sum of current consumption (module + devices)		= _____ A

1) See manufacturer's specifications

Tab. 3.1



An additional power supply of 1.6 A per port can be made available through the load voltage supply U_{VAL} .

**Caution**

Malfunctions due to exceeding of the maximum permissible current consumption.

- Make sure that the current consumption from $U_{EL/SEN}$ does not exceed the maximum permissible value of 1.6 A per port.
- Make sure that the current consumption from U_{VAL} does not exceed the maximum permissible value of 1.6 A per port.
- Observe the total current consumption of the CPX terminal. This is dependent on expansion of the CPX terminal (→ CPX system description P.BE-CPX-SYS-...).

**Note**

The actuator technology supplied through the load voltage supply U_{VAL} can be potential-isolated compared to $U_{EL/SEN}$.

3.6 Connection with the host system

For the required connection between the module described here in the CPX terminal and the higher-order host system, it is required that the configuration file entry that corresponds to the current configuration presetting of the module is selected in the host system (→ 2.4.1 I/O configuration presetting). Only in this case is the module correctly recognised when the system is run up. Otherwise, no communication can be built up and no diagnostic/error message is output.

3.7 Ensuring degree of protection IP65/67

**Note**

To comply with degree of protection IP65/IP67:

- Seal unused ports with corresponding protective caps from our catalogue (not included in delivery, → www.festo.com/catalogue).

The ports X3 and X4 are without function and sealed at the factory with a protective cap.

4 Commissioning

4.1 Configuration

4.1.1 Establish address space

The address space that the module makes available at both ports is manually established via the DIL switches S1.1 and S1.2 (→ 2.4.2 Setting of the I/O configuration presetting).



Connected devices can also be replaced during operation if the configuration presetting is sufficient for the required address space.

The specifications regarding design of the connecting cables must be observed here (→ 3.3 Connecting cables).

Example

The following devices are connected to the module at system start:

- input module with 16 inputs (2 bytes I)
- valve terminal with 64 outputs (8 bytes O).



The number of required I/O bytes results from the device with the highest I/O requirements. In this example, 8 bytes for the valve terminal.

The DIL switch group 1 must accordingly be set as follows:

DIL switch group 1	S1.1	S1.2	Function
	OFF	ON	8 bytes inputs and outputs

Tab. 4.1

In cases in which the reserved address space is not completely used by the connected devices, this results automatically in input and output addresses to which no device input or output is assigned.

Unused I/O addresses

Input addresses to which no device input is assigned are automatically set to the value “0” in the CPX system. Output addresses to which no device output is assigned are ignored in data transmission.

Sequence at system start

When the system is started, the module builds up an IO-Link connection to connected devices and checks the communication.



Note

Only after the CPX terminal is completely run up and a connection is made to the host system is activation by parameter of the load voltage supply (PL) possible (→ 4.6.4 Parameter “port settings”).

Communication with the host system

To make a connection set-up between the CPX terminal and higher-order controller possible, the manual configuration presetting of the module must agree with the respective entry of the corresponding fieldbus configuration file (➔ 3.6 Connection with the host system).

4.1.2 Address assignment in the CPX system

Address spaces are assigned in the CPX system corresponding to the selected configuration presetting. These address spaces are thereby filled “from below”, that is, the starting point is the least significant address (LSB). The unused MSBs expire.

The distribution of the device addresses to the address space of the module would look as follows if the devices from the above example are used (➔ 4.1.1 Establish address space):

Allocation of inputs (2 bytes):

Device	Device address	Input address module
Port 1 (2 bytes)	Byte 0	Byte 0
	Byte 1	Byte 1
	–	Byte 2
	–	...
	–	Byte 7
Port 2 (unused)	–	Byte 0
	–	Byte 1
	–	Byte 2
	–	...
	–	Byte 7

Legend: White = assigned; grey = unused

Allocation of outputs (8 bytes):

Device	Device address	Output address module
Port 1 (unused)	–	Byte 0
	–	Byte 1
	–	Byte 2
	–	...
	–	Byte 7
Port 2 (8 bytes)	Byte 0	Byte 0
	Byte 1	Byte 1
	Byte 2	Byte 2

	Byte 7	Byte 7

Legend: White = assigned; grey = unused



Unused bytes are filled with 0.

4.2 Procedure for commissioning

In order to avoid connecting and configuration errors, commissioning in steps is required.

Procedure:

1. Check the module and the devices (→ 4.3 Prepare commissioning)
2. Determine the configuration presetting (→ 2.4.1 I/O configuration presetting)
3. If required: Parameterisation of the module and the devices (→ 4.6 Parameters)
4. Check power supplies (→ 3.5 Connecting the power supply)
5. Commissioning of the entire system (→ description of the specific CPX bus node).

4.3 Prepare commissioning



Note

- Do not connect the CPX terminal to a higher-order controller yet to prepare for commissioning.

You will thus avoid addressing faults which may occur in various fieldbus systems when address ranges are modified during operation.



The host system integration of the module might take place through a device description file, dependent on the CPX bus node used.

You can find the corresponding description files in the Internet (→ www.festo.com/sp).

4.3.1 Check the module and the connected devices

- Check, if necessary, the position of the DIL switches to guarantee the desired configuration presetting.
- Check the module for proper seating in the interlinking block.
- Check whether the connected devices correspond to the entry of the configuration file on the host system (→ 3.6 Connection with the host system).
- Check whether the connected devices are distributed to the ports corresponding to their priority for the diagnostic/error messages (→ 5.2.1 Priorities of the diagnostic/error messages).
- Check whether the current consumption of the connected devices and the other CPX modules corresponds to the specifications and limit values (→ 3.5 Connecting the power supply).
- Check the power supply connections at the interlinking blocks.

4.4 Behaviour in case of malfunctions in operation

If there is a malfunction at a port during operation, e.g. due to a broken cable, etc., this will be indicated by flashing or illumination of the LED indicator (X1 ... X2) of the corresponding port at the module. The behaviour of the affected device is dependent on the device type.

Moreover, additional diagnostic information of the module is available and can be called up both via the fieldbus used as well as via the Festo Maintenance Tool software (CPX-FMT) or the operator unit (CPX-MM).



Detailed information on the diagnostics functions (→ 2.3 LED indicators and 5 Diagnostics and error handling).

Start of the CPX terminal with “Stored parameters” system setting

If the start setting “Stored parameters” is configured in the system settings of the CPX terminal instead of “Standard parameters”, the current assignment of the I/O address space of all modules remains permanently stored in the CPX terminal.

4.5 Notes on operation



Warning

Accidental exchange of the connected devices.

Caution with subsequent modification of the port assignment:

- Make sure that devices are not separated from a port and accidentally connected to another port.

For unique identification of the devices, use identification labels (type IBS-6x10 or IBS-9x20) .

- Before starting the system, check whether the port assignment corresponds to the configuration in the host system.

In this way, you avoid accidental movements of the actuators.



Warning

Accidental activation of actuators!

An incorrect status of the valves and outputs can lead to dangerous situations!

- Make sure that valves and outputs are put in a safe status when malfunctions occur.



Note

Please note the following if the outputs of a valve terminal are reset after master stop, fieldbus interruption or malfunction:

- Monostable valves move to the initial position.
- Double solenoid valves remain in the current position.
- Mid-position valves go into mid-position (pressurized, exhausted or closed, depending on valve type).

4.6 Parameters

The module can be adapted to the respective use situation through the configuration of various parameters. In addition, read-only parameters are available for reading out system statuses.

4.6.1 Overview of module parameters

The following table includes an overview of the user-relevant module parameters.

The standard settings are shown in **bold** characters.

Relative address mod. par.	R/W	Bit 7	Bit 6	Bit 5	Bit 4	Bit 3	Bit 2	Bit 1	Bit 0	Module parameter
0	RW						X			Monitoring U _{OUT} /U _{VAL} 0 = inactive 1 = active
6	RW	X								Behaviour after port short circuit 0 = leave switched off 1 = switch on again
7	RW								X	Port settings Port 1 – PL supply 0 = inactive 1 = active
8									X	Port settings Port 2 – PL supply 0 = inactive 1 = active
11 ... 12	RW	16-bit (hexadecimal)							ISDU_Index	
13	RW	8-bit (hexadecimal)							ISDU_SubIndex	
14	RW	8-bit (hexadecimal)							ISDU_DataLength	
15 ... 22	RW	8 bytes (hexadecimal)							Data 0 ... 7	
23 ... 30	RW	8 bytes (hexadecimal)							Data 8 ... 15	
31 ... 38	RW	8 bytes (hexadecimal)							Data 16 ... 23	
39 ... 46	RW	8 bytes (hexadecimal)							Data 24 ... 31	
47	RW		X	X	X	X	X	X		Mailbox-CTRL Port START BUSY READY ERROR R/W

Relative address mod. par.	R/W	Bit 7	Bit 6	Bit 5	Bit 4	Bit 3	Bit 2	Bit 1	Bit 0	Module parameter
48 ... 49	RO	16-bit (hexadecimal)								Vendor ID – port 1
50 ... 51		16-bit (hexadecimal)								Vendor ID – port 2
52 ... 54	RO	24-bit (hexadecimal)								Device ID – port 1
55 ... 57		24-bit (hexadecimal)								Device ID – port 2
58 ... 59	RO	16-bit (hexadecimal)								IO-Link device error code – port 1
60 ... 61		16-bit (hexadecimal)								IO-Link device error code – port 2

Tab. 4.2



The module parameters under the relative addresses 1 ... 5 are not used by this product.

4.6.2 Parameter “Monitoring U_{OUT}/U_{VAL} ”

Through the parameter “Monitoring U_{OUT}/U_{VAL} ” (→ Tab. 4.2), monitoring of the supply voltage U_{OUT} or U_{VAL} , which is activated as standard, can be deactivated.

When the monitoring is deactivated, any undervoltage that then occurs can be ignored. If the module already reports an undervoltage status (related to U_{OUT}/U_{VAL}), this message can be deleted by setting this parameter to “inactive”.

Setting of this parameter applies for the entire module, that is, for all ports equally.

4.6.3 Parameter “Behaviour after port short circuit”

Through the parameter “Behaviour after port short circuit” (→ Tab. 4.2), the status of supply voltage can be established for a device after elimination of a short circuit in a connecting cable.

After the short circuit is eliminated, the power supply for the corresponding device can

- remain switched off (setting “Leave switched-off”) or
- automatically be switched back on (setting “Switch back on”).

With access via the Festo Maintenance Tool software (CPX-FMT) or the operator unit (CPX-MMI), the parameter can be selected and changed separately.

4.6.4 Parameter “port settings”

Through the “port settings” parameter (→ Tab. 4.2), the load voltage supply, which is parameterised inactive as standard, can be activated for each port.

4.7 Commissioning with the operator unit (CPX-MMI)

The operator unit (CPX-MMI) offers convenient or extended functions, which will support you in commissioning the module.

This section includes an overview of the specific commissioning functions for the module:

- general information (➔ 4.7.1 Menu commands of the module on the operator unit (CPX-MMI))
- for display of the signal statuses, see section (➔ 4.7.2 Observe signal statuses (monitoring))
- parameterisation (➔ 4.7.3 Parameterisation with the operator unit (CPX-MMI))



General information on the operator unit (CPX-MMI) and on commissioning the CPX terminal using it can be found in the description (P.BE-CPX-MMI-1-...).



Warning

The connected actuator technology can move unexpectedly!
Modification of the signal statuses and parameters using the operator unit can trigger dangerous movements of the connected actuator technology.

- Make sure that nobody is in the positioning range of the connected actuators and be very careful with parameterisation or manipulation of signal statuses.
- Observe the notes on “Force”, “Idle mode” and “Fail safe” in the CPX system description and in the description for the operator unit if the bus node used supports these parameterisation types.

4.7.1 Menu commands of the module on the operator unit (CPX-MMI)

Fig. 4.1 shows as an example the special menu structure for the module described here. For reasons of clarity, only the parameter name is shown for the parameters.

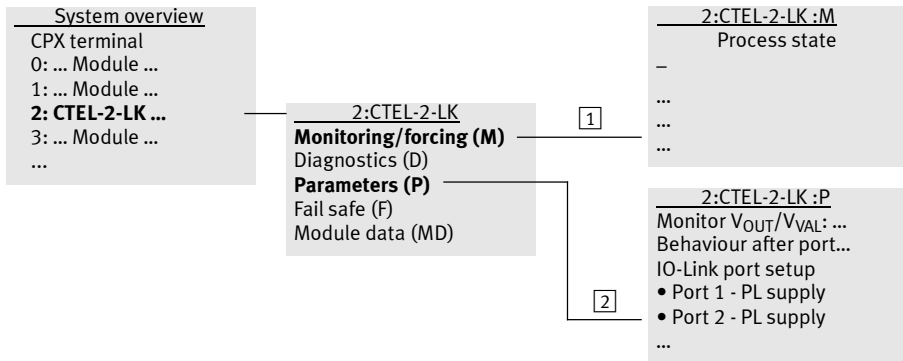

1 “Monitoring/forcing” menu (also “Fail safe”) (➔ 4.7.2 Observe signal statuses (monitoring))

2 “Parameters” menu (➔ 4.7.3 Parameterisation with the operator unit (CPX-MMI))

Fig. 4.1

4.7.2 Observe signal statuses (monitoring)

You can use the operator unit (CPX-MMI) to observe the signal statuses of the connected (and recognised) devices.

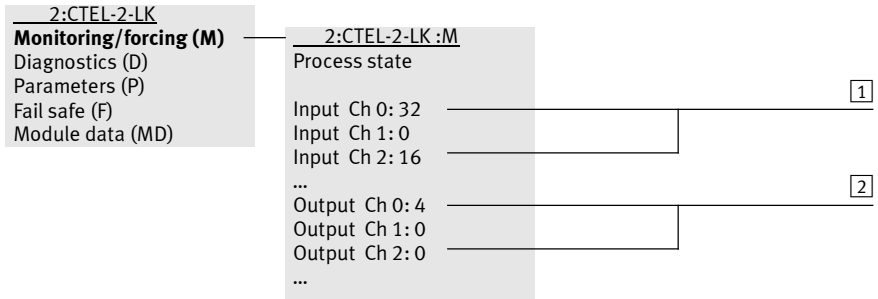

- 1 Channels of the device at the first assigned port (here input module)
- 2 Channels of the devices at further assigned ports (here output module)

Fig. 4.2

You can also call up the “Force” function via the “Monitoring ...” menu. This function allows you to force signal statuses during the commissioning phase for test purposes. The same representation of the devices also applies correspondingly to the “Idle mode” and “Fail safe” functions.

4.7.3 Parameterisation with the operator unit (CPX-MMI)

You can use the operator unit (CPX-MMI) to parameterise for test purposes in the commissioning phase, for troubleshooting or for fieldbus protocols which do not support parameterisation via the fieldbus (→ Fig. 4.3).

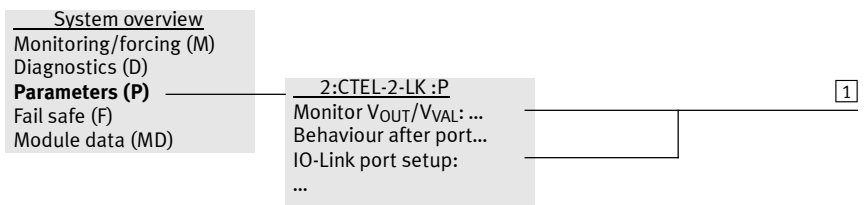

- 1 Parameter module

Fig. 4.3

4.8 Commissioning with the Festo Maintenance Tool software (CPX-FMT)

The Festo Maintenance Tool software (CPX-FMT) can also be used for commissioning, parameterisation and extended diagnostics of the module. You can find the current software version in the Internet (→ www.festo.com/sp).

The module parameters are depicted in the following diagram as an example (→ Fig. 4.4).

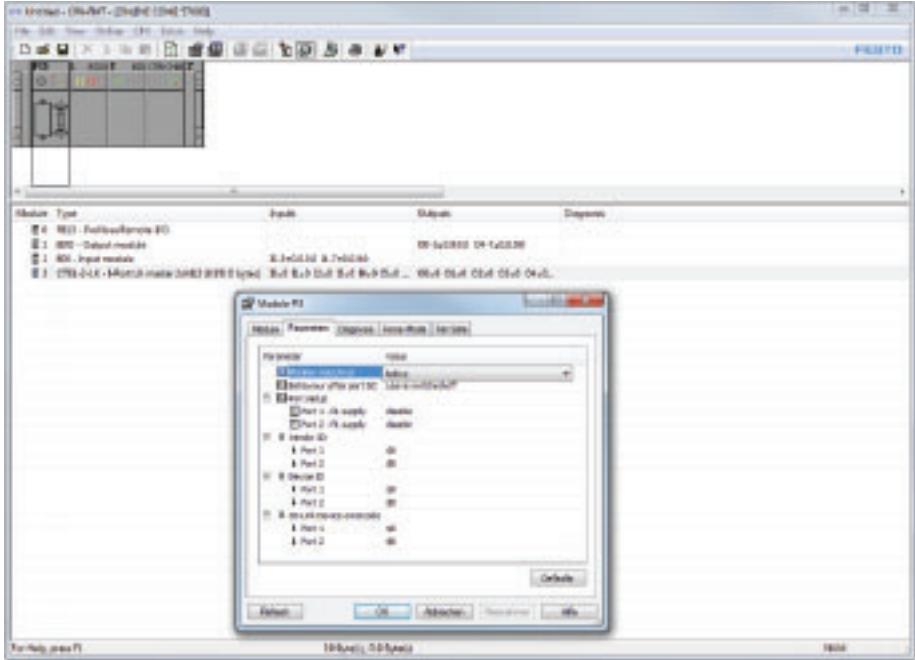

Fig. 4.4



Warning

The connected actuator technology can move unexpectedly! Modification of the signal statuses and parameters with the FMT can trigger dangerous movements of the connected actuator technology.

- Make sure that nobody is in the positioning range of the connected actuators and be very careful with parameterisation or manipulation of signal statuses.
- Observe the notes on “Force”, “Idle mode” and “Fail safe” in the CPX system description (P.BE-CPX-SYS-...) and in the online help of the FMT.

5 Diagnostics and error handling

5.1 Summary of diagnostics options

The module supports various options for diagnostics.

Diagnostics option	Explanation/advantages	Detailed description
Error messages	The module reports specific malfunctions as error messages (error numbers) to the CPX bus node. Advantage: Error messages can be evaluated via the CPX bus node, operator unit (CPX-MMI) or FMT.	→ Section 5.2 → CPX system description (P.BE-CPX-SYS-...)
LED indicator	The module reports specific malfunctions as error messages (error numbers) to the CPX bus node. Advantage: Fast “on-site” error detection	→ Section 5.3
Status bits, I/O diagnostic interface and specific diagnostic functions	The errors recognised by the module are reported in some cases to the CPX bus node or CPX-FEC with special additional information. Advantage: Fast access to error messages via the fieldbus, etc.	→ Section 5.4 → CPX system description (P.BE-CPX-SYS-...) → CPX bus node description
Diagnostics via the operator unit (CPX-MMI)	Diagnostic information can be displayed on the operator unit in a convenient and menu-driven manner. Advantage: Fast “on-site” error detection	→ Section 5.5 → Operator unit description (P.BE-CPX-MMI-1-...)
Diagnostics via the Festo Maintenance Tool (CPX-FMT) software	The FMT offers the option to display diagnostic information on a PC. Advantage: Fast “on-site” error detection; diagnostics also possible from a higher automation level.	→ Section 5.6 → Online help for Festo Maintenance Tool (CPX-FMT) software

Tab. 5.1



Note

The available diagnostic information may depend on the settings of the CPX bus node or on the parameterisation.

5.2 Diagnostics/error messages



Note

A requirement for transmission of diagnostic/error messages (if supported by the respective fieldbus) is an existing connection to the host system (→ 3.6 Connection with the host system) and a corresponding parameterisation of the module (→ 4.6 Parameters).

5.2.1 Priorities of the diagnostic/error messages

The module differentiates 3 different instances (system + 2 ports) that can cause the diagnostic/error messages. These instances have different priorities in the CPX system.

If several diagnostic/error messages cannot be displayed simultaneously on the fieldbus side, the error message with the highest priority is displayed.

Priority	Error instance	Description
Highest	System	Error in the module
•	Port 1	Error in the module at port 1
Lowest	Port 2	Error in the module at port 2

Tab. 5.2



- The error instances of the ports are assigned standard to the outputs. If no outputs are intended in the configuration of the module, the error instances are assigned to the inputs.
- In the CPX terminal, the individual modules also have prioritisation. This runs from the CPX bus node (always completely to the left) descending to the right. Modules that are closer to the CPX bus node thus have a higher priority than modules that are further to the right.
- Within a CPX terminal, diagnostic/error messages of inputs have priority over diagnostic/error messages of outputs. This principle of error prioritisation is also used in the module described here.

5.2.2 Diagnostic/error messages by CPX error numbers

Subsequently shown is an overview of the CPX errors as well as possible causes and information for error handling (→ Tab. 5.3).

CPX error number	Description of possible causes	Error handling
0	Device OK	No action required
1	General error – device NOK, general diagnostics – hardware error – device replacement – component error – repair or replacement – general error in power supply – fuse triggered – device software error	• Check device, eliminate errors
	– mass error – temperature overload	• Check installation
	– technology-specific application error	• Reset device
	Measuring range exceeded	• Check application
2	Short circuit	• Check installation
3	Wire break	• Check installation
5	Error in the power supply – primary voltage/main power supply too low – undervoltage PL device supply (only relevant if PL monitoring is active in a device)	• Check power supply
9	Below minimum value	
	– device temperature limit fallen below	• Check installation
	– error in memory buffering – low battery level	• Check batteries
10	Maximum value not reached	
	– device temperature limit exceeded	• Check installation
	– primary voltage/main power supply too low	• Check power supply
24	Process variable range underflow	• Process data inconsistent, check
25	Process variable range overflow	• Process data inconsistent, check

CPX error number	Description of possible causes	Error handling
29	Parameter error	
	– invalid parameters received from the host	• Check parameterisation
	– parameter error	• Check data sheet and values
	– missing parameters	• Check data sheet
	– changed parameter	• Check configuration
39	Maintenance required	• Process data inconsistent, check
56	Short circuit at port (PS/PL supply or communication signal)	• Check installation
57	Device missing/failed	• Check configuration
58	Port configuration error	• Check configuration

Tab. 5.3



When the module is accessed via CPX-FMT software or the CPX-MMI operator unit, the current error for each port can be determined more precisely by means of an event code if the error is due to the connected device.

A list of the relevant event codes (→ A.2 Event codes).

5.3 Diagnostics via LED indicators

LED indicators for diagnostics of the CPX terminal are available on the module and the devices. Description of the LED indicators on the module (→ 2.3 LED indicators).



Significance of the LED indicators on the devices can be found in the description of the respective module.

5.4 Diagnostics via the CPX bus node

Malfunctions of the connected devices are reported to the CPX bus node as CPX error messages. Malfunctions of the module itself are reported as CPX errors only if the module is operated with at least one device.

The following sections contain the special features of the representation for the CPX-specific diagnostics options.

- status bits (→ 5.4.1 Status bits of the CPX terminal)
- I/O diagnostics interface (→ 5.4.2 I/O diagnostic interface and diagnostic memory)
- diagnostic memory (→ 5.4.2 I/O diagnostic interface and diagnostic memory)

5.4.1 Status bits of the CPX terminal

Tab. 5.4 shows the effect of the module on the status bits of the CPX terminal.

Bit	Diagnostic information with logic 1	Description	Module cause of error
0	Error at the valve	Module type in which the error has occurred	–
1	Error at output		–
2	Error at input		–
3	Error at analogue module/technology module (function module)		Bit 3 is set in all errors of the module.
4	Undervoltage	Error type	Error number 5 ¹⁾
5	Short circuit/overload		Error number 2 ¹⁾
6	Wire break		–
7	Other error	Error type	Error number 34, 35, 36

1) → Tab. 5.3

Tab. 5.4



Further notes on the function and content of the status bits are found in the CPX system description (P.BE-CPX-SYS-...).

5.4.2 I/O diagnostic interface and diagnostic memory

The module reports specific diagnostic information to the CPX bus node.

Diagnostics related to individual devices are possible through the I/O diagnostic interface and the diagnostic memory of the CPX terminal. The devices connected to a module are treated as input or output addresses within the CPX terminal.



Detailed information on the I/O diagnostic interface and diagnostic memory can be found in the CPX system description (P.BE-CPX-SYS-...).

5.5 Diagnostics with the operator unit (CPX-MMI)

The operator unit (CPX-MMI) offers convenient or extended functions which assist you in diagnosing and troubleshooting with the module.



Additional diagnostic functions of the operator unit (CPX-MMI) have already been described in the “Commissioning” chapter (→ 4.7 Commissioning with the operator unit (CPX-MMI)).

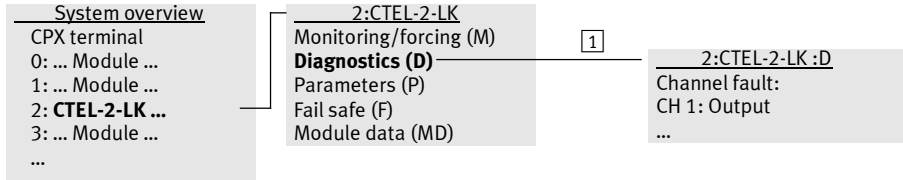

1 “Diagnostics” menu

Fig. 5.1



General information on the operation and commissioning of the CPX terminal using the operator unit can be found in the description for the operator unit (P.BE-CPX-MMI-1-...).

5.6 Diagnostics with the Festo Maintenance Tool (CPX-FMT)

The Festo Maintenance Tool (CPX-FMT) software offers extended functions for diagnostics and troubleshooting.

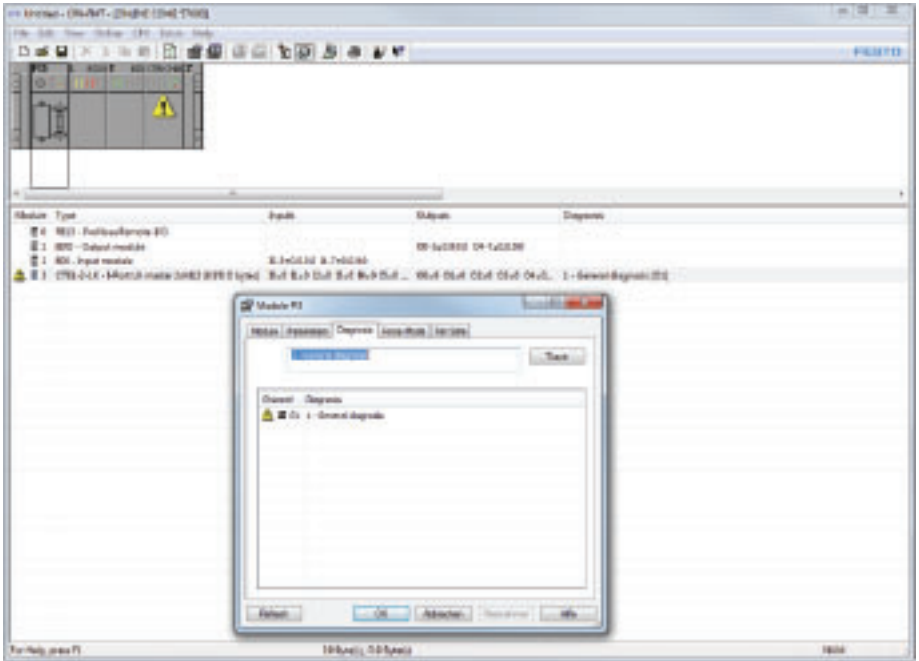

Fig. 5.2



General information on operating and commissioning the CPX terminal with the CPX-FMT software can be found in the CPX system description (P.BE-CPX-SYS-...) and in the online help of the CPX-FMT software.

5.7 Behaviour after lost connection to the device

With an interruption of the communication between the module and a device (e.g. through a wire break), the module puts out various diagnostic/error messages.

During operation, the ports are checked only for the set inputs and outputs assigned in the CPX system.



If input bytes are assigned for the separated module in the CPX system, these are automatically set to “0”.

For existing output bytes, their last known status is saved.

After an interruption is determined, the relevant port is queried cyclically and checked for a connection-capable device. If a device is recognised, the following procedures are possible:

The recognised device agrees with the manual configuration.

The system can continue to be operated without limitation.



If the number of I/O bytes of the recognised device is less than the number established in the manual configuration, the I/O bytes used are assigned to the “lower end” of the reserved address space in the CPX system.

The unassigned bytes at the “upper end” remain unused.

Example:

Configuration with 8 byte inputs and outputs. A device with 4 bytes is connected.

- The 4 bytes of the device are assigned to the first 4 bytes in the address space of the port.
- The remaining 4 bytes remain unused.

Port	I/O configuration 8 bytes	Device: 4 bytes
	Byte 0	Byte 0
	Byte 1	Byte 1
	Byte 2	Byte 2
	Byte 3	Byte 3
	Byte 4	X
	Byte 5	X
	Byte 6	X
	Byte 7	X

Tab. 5.5

The recognised device requires more I/O bytes than are established in the manual configuration.

The system can still be operated. But the I/O bytes that “project” beyond the reserved address space are ignored.

Example:

Configuration with 8 byte inputs and outputs. A device with 12 bytes is connected.

- The first 8 bytes of the device are assigned to the 8 bytes in the address space of the port.
- The remaining 4 bytes of the device remain unused.

Port	I/O configuration 8 bytes	Device: 12 bytes
Port	Byte 0	Byte 0
	Byte 1	Byte 1
	Byte 2	Byte 2
	Byte 3	Byte 3
	Byte 4	Byte 4
	Byte 5	Byte 5
	Byte 6	Byte 6
	Byte 7	Byte 7
	X	Byte 8
	X	Byte 9
	X	Byte 10
	X	Byte 11

Tab. 5.6

5.8 Behaviour in the event of power supply errors

If the module recognises a short circuit or overload on the connecting cable of a port, the affected port in each case is completely switched off, i.e. power supply (PS) and load voltage supply (PL).

Behaviour after elimination of the error can be set via the parameter “Behaviour after port short circuit” (→ 4.6.3 Parameter “Behaviour after port short circuit”).

A Technical appendix

A.1 Technical data

General	
General technical data	→ CPX system description (P.BE-CPX-SYS-...)
Degree of protection through housing ¹⁾ in accordance with IEC 60529, completely mounted, plug connector inserted or with protective caps ²⁾ .	IP65/IP67
Protection against electric shock (Protection against direct and indirect contact as per IEC 60204-1)	Through PELV power supply unit (Protected Extra Low Voltage)
Module code (CPX-specific)	194/1 (C2/01)
Module identifier (in operator unit)	CTEL-2-LK I-port LK master
Part number	2900543
Dimensions W x L x H	50 x 107 x 55 mm (incl. interlinking block)
Product weight	Approx. 110 g
Housing material information	Reinforced PA, PC
Note on materials	RoHS-compliant
Ambient temperature	-5 ... +50 °C
Storage temperature	-20 ... +70 °C
Humidity/heat (corresponding to IEC 60068-2-30)	95 %/50 °C
Vibration and shock (in accordance with IEC 60068): Vibration (part 2 ... 6) Shock (part 2 ... 27) Continuous shock resistance (part 2 ... 29)	Mounting-dependent: Wall mounting: SG 2, H-rail mounting: SG 1 Wall mounting: SG 2, H-rail mounting: SG 1 Wall and H-rail mounting: SG 1

1) Note that connected devices might only fulfil a lower degree of protection.

2) Cover caps from Festo, type ISK-M12, for ports X3 and X4, included in delivery.

Tab. A.1

Power supply	
Operating and load voltage range DC The following special features apply: – recommended minimum voltage PL (U_{VAL}) for devices on connecting cables > 5 m	18 ... 30 V → CPX system description (P.BE-CPX-SYS-...) 21.6 V (24 V –10 %)
Nominal operating voltage DC	24 V
Current consumption module (internal electronics, without connected devices)	Typ. 65 mA
Maximum current consumption per port – PS from operating voltage supply, electronics/sensors ($U_{EL/SEN}$) – PL from load voltage supply, valves (U_{VAL})	1.6 A 1.6 A
Electrical isolation – between operating voltage supply, electronics/sensors ($U_{EL/SEN}$) and load voltage supply, valves (U_{VAL}) – supply PS/PL between the ports	Yes, with potential-isolated supply No
Functional earth connection	Optional, through earthing plate
Mains buffering time corresp. IEC 1131, part 2	10 ms

Tab. A.2

Module and devices	
Feature – protocol – number of ports – maximum number of devices per port – maximum cable length per port – maximum number of I/O per port – transmission rate (per port) – internal cycle time (dependent on the connected devices) – control elements	Based on IO-Link (with restrictions) 2 1 20 m 16 bytes I/16 bytes O 230.4 kBit/s (COM3) 38.4 kBit/s (COM2) 4.8 kBit/s (COM1) Min. 1 ms (per 1 byte of user data parallel each connected device) DIL switches
Electrical connection	2 x socket M12, 5-pin, A-coded
LED indicators – status system supply – status load voltage – communication status/diagnostics – module status	
Short circuit protection, module – device supply (PS) – load supply (PL) – behaviour after short circuit	Internal (electronic) separate for each port Internal (electronic) separate for each port Dependent on parameter “Behaviour after port short circuit”
Parameterisation – module parameters – diagnostic behaviour – fail-safe mode per channel – forcing per channel – idle mode per channel	
Reverse polarity protection	Separate for each system and load voltage, not separated per port
Diagnostics Module-oriented diagnostics Undervoltage/short circuit modules Communication errors	Undervoltage PS Undervoltage PL (through device) Communication errors Short-circuit PS/PL Device error
Trigger level, undervoltage identification PS	Approx. 17.5 V (measured in the module)
Hysteresis undervoltage identification PS	Approx. 500 mV (measured in the module)

Tab. A.3

A.2 Event codes

Within the communication between module and device, so-called events are used for status diagnostics, which include an error code (event code), each with a constant length of 2 bytes.

Event code	Error instance	Description	CPX error no.
---	Internal	Short circuit at port (PS/PL supply or communication signal)	56
---	Internal	Configuration error	58
---	Internal	Device missing/failed	57
---	Internal	Invalid parameters received from the host (parameterisation error)	29
0x...	Device	All other event codes not specified in this list	1
0x0000	Device	Device OK	0
0x1000	Device	Device NOK, general diagnostics	1
0x4000	Device	Temperature overload	1
0x4210	Device	Device has exceeded temperature limit	10
0x4220	Device	Device has fallen below temperature limit	9
0x5000	Device	Hardware error – device replacement	1
0x5010	Device	Component error – repair or replacement	1
0x5011	Device	Error in memory buffering - check batteries	9
0x5012	Device	Low battery level – check batteries	9
0x5100	Device	General error in power supply	1
0x5101	Device	Fuse triggered	1
0x5110	Device	Primary voltage/main power supply too high	10
0x5111	Device	Primary voltage/main power supply too low	5
0x5112	Device	Undervoltage PL device (only relevant if PL monitoring is active in a device)	5
0x6000	Device	Device software error	1
0x6320	Device	Parameter error – check data sheet and values	29
0x6321	Device	Missing parameters – check data sheet	29
0x6350	Device	Changed parameter – check configuration	29
0x7700	Device	Wire break at device peripherals – check installation	3
0x7701 ... 0x770F	Device	Wire break at device 1 ... device 15 Peripherals – check installation	3
0x7710	Device	Short circuit – check installation	2
0x7711	Device	Mass error – check installation	1
0x8C00	Device	Technology-specific application error – device reset	1
0x8C10	Device	Process variable range overflow – process data inconsistent	25
0x8C20	Device	Measuring range exceeded – check application	1

Event code	Error instance	Description	CPX error no.
0x8C30	Device	Process variable range underflow – process data inconsistent	24
0x8C40	Device	Maintenance required – cleaning	39
0x8C41	Device	Maintenance required – refill	39
0x8C42	Device	Maintenance required – replace wearing parts	39

Tab. A.4

A.3 Accessories



Accessories → www.festo.com/catalogue

B Glossary

B.1 List of abbreviations

The following product-specific terms and abbreviations are used in this description:

Term/abbreviation	Description
A	Digital output
CPX bus node	Provide the connection to specific fieldbuses. Communicate with connected I/O modules and monitor their functionality.
CPX-FMT	Festo Maintenance Tool. PC software for commissioning, configuration and extended diagnostics of CPX terminals.
CPX-MMI	Multi-media interface, operator unit for reading and configuring CPX systems.
CPX modules	Collective term for the various modules which can be integrated into a CPX terminal.
CPX system	Totality of the software of all CPX modules of a CPX terminal.
CPX terminal	Totality of the combined CPX modules, including a CPX bus node, without pneumatics.
Device	Device that can be connected to the module via the interface.
E	Digital input
I-module	Input module
I/O	Digital inputs and outputs
I/O address	Addressing the inputs and outputs
I/O length	Number of bytes available for inputs and outputs.
IO-Link	Protected designation for a network system for connection of sensors and actuators to an automation system.
I/O modules	Collective term for the modules which provide digital inputs and outputs (e.g. CPX I/O modules, IO-Link input and IO-Link output modules).
LSB	Least significant bit/byte (bit/byte with the lowest value).
MSB	Most significant bit/byte (bit/byte with the highest value).
O module	Output module
Port	Interface for the connection between module and device.
SCS	Short circuit in the power supply of the system.

Tab. B.1

Index

A		Diagnostics/error messages	32
Accessories	44	– by CPX error numbers	33
Address assignment	23	– error handling	33
Address space	13	– priorities	32
Addresses	13, 23	DIL switches	14
Addressing errors	24	Dimensions	40
		Dismounting	17
B		E	
Bus node	45	Event codes	43
C		F	
Commissioning		Festo Maintenance Tool	45
– with the Festo Maintenance Tool software		– Commissioning with the Festo Maintenance	
(CPX-FMT)	30	Tool software (CPX-FMT)	30
– with the operator unit (CPX-MMI)	28	H	
Configuration	22	Host system	21
Configuration presetting	13	I	
Connecting cables	17	I/O	45
Connection to the device lost	38	I/O address	45
CPX error number	33, 43	I/O configuration presetting	13
CPX modules	45	I/O length	45
CPX system	45	I/O modules	45
CPX terminal	45	Intended use	6
CPX-FMT	45	Interfaces	10
CPX-MMI. <i>See</i> Operator unit		IO-Link	10, 45
D		– description	10
Degree of protection	21	– pin allocation	11
Device	45	L	
– check	24	LED indicators	11
– connect	18	– PL	12
– connection lost	38	– PS	12
Device description file	24	– X1 ... X2	12
Diagnostics		List of abbreviations	45
– via LEDs	34	Load voltage supply	11
– via the CPX bus node	35	LSB	45
– with the Festo Maintenance Tool software			
(CPX-FMT)	37		
– with the operator unit (CPX-MMI)	36		
Diagnostics options, overview	31		

M		Part number	40
Mounting	16	Port	45
MSB	45	Power supply	19
		– connect	19
N		– determine current consumption	20
Notes on the documentation	5	– error in the supply voltage	39
O		R	
Operating voltage supply	11	Repair. <i>See</i> Service	
Operator unit		Reverse polarity protection	42
– commissioning with the	28	S	
– menu commands	28	Service	5
– monitoring	29	Slave module. <i>See</i> Device	
– parameterisation with the operator unit ...	29	T	
Overview of module parameters	26	Technical data	40
P		W	
Parameter	26 - 30	Weight	40
– “Behaviour after port short circuit”	27		
– “Port settings”	27		
– “Monitoring U_{OUT}/U_{VAL} ”	27		

Copyright:
Festo AG & Co. KG
Postfach
73726 Esslingen
Germany

Phone:
+49 711 347-0

Fax:
+49 711 347-2144

e-mail:
service_international@festo.com

Internet:
www.festo.com

Original: de

Reproduction, distribution or sale of this document or communication of its contents to others without express authorization is prohibited. Offenders will be liable for damages. All rights reserved in the event that a patent, utility model or design patent is registered.