

Motor controller

CMMP-AS-...-M3

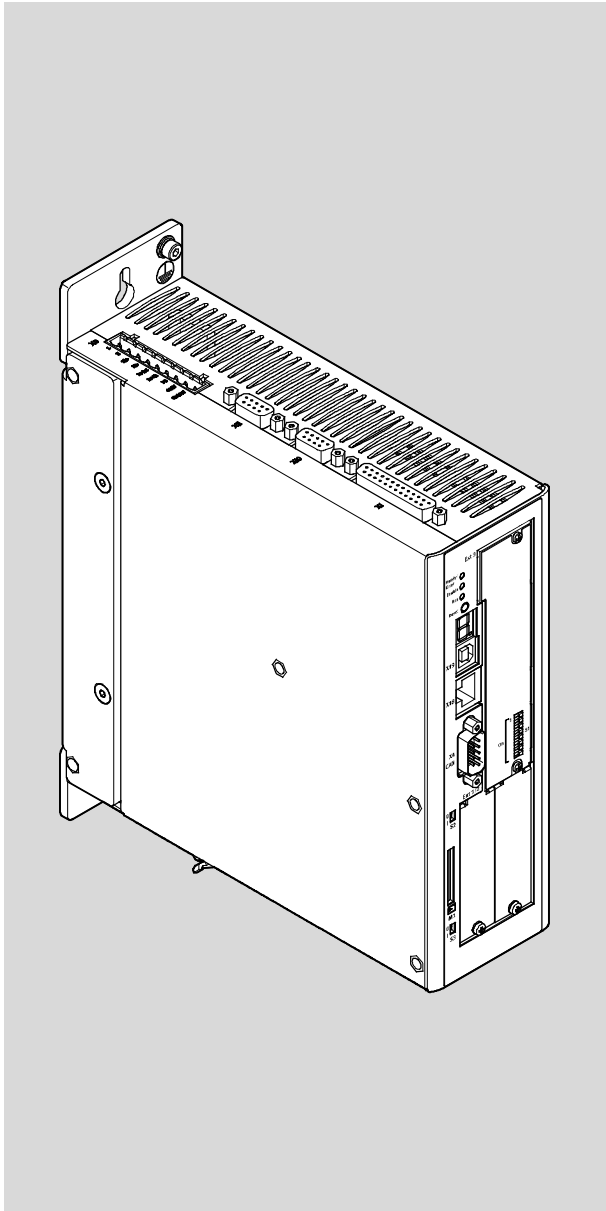

FESTO

Description

Mounting and installation

for motor controller
CMMP-AS-...-M3

Translation of the original instructions
GDCP-CMMP-M3-HW-EN

CANopen®, Heidenhain®, EnDat®, PHOENIX®, Windows® are registered trademarks of the respective trademark owners in certain countries.

Identification of hazards and instructions on how to prevent them:



Danger

Immediate dangers which can lead to death or serious injuries.



Warning

Hazards that can cause death or serious injuries.



Caution

Hazards that can cause minor injuries or serious material damage.

Other symbols:



Note

Material damage or loss of function.



Recommendations, tips, references to other documentation.



Essential or useful accessories.



Information on environmentally sound usage.

Text designations:

- Activities that may be carried out in any order.
- 1. Activities that should be carried out in the order stated.
- General lists.

Inhaltsverzeichnis – CMMP-AS-...-M3

1	Safety and requirements for product use	9
1.1	Safety	9
1.1.1	Safety instructions for commissioning, repair and de-commissioning	9
1.1.2	Protection against electric shock through protective extra-low voltage (PELV)	10
1.1.3	Intended use	10
1.2	Requirements for product use	11
1.2.1	Transport and storage conditions	11
1.2.2	Technical requirements	11
1.2.3	Qualification of the specialists (requirements for the personnel)	11
1.2.4	Range of application and certifications	11
2	Product overview	13
2.1	The entire system for the CMMP-AS-...-M3	13
2.2	Scope of delivery	14
2.3	Device view	15
3	Mechanical installation	19
3.1	Important instructions	19
3.2	Mounting	20
3.2.1	Module in slot Ext3	20
3.2.2	Interface in slot Ext1 or Ext2 (optional)	22
3.2.3	Motor controller	23
4	Electrical installation	25
4.1	Safety instructions	25
4.2	Allocation of the plug connectors	27
4.3	Connection: I/O communication [X1]	31
4.3.1	Plug [X1]:	31
4.3.2	Pin assignment [X1]	31
4.4	Connection: Resolver [X2A]	34
4.4.1	Plug [X2A]	34
4.4.2	Pin assignment [X2A]	34
4.5	Connection: Encoder [X2B]	35
4.5.1	Plug [X2B]	35
4.5.2	Pin assignment [X2B]	35
4.6	Connection: CAN bus [X4]	38
4.6.1	Plug [X4]	38
4.6.2	Pin assignment [X4]	38

4.7	Connection: Motor [X6]	39
4.7.1	Plug [X6]	39
4.7.2	Pin assignment [X6]	39
4.8	Connection: Voltage supply [X9]	41
4.8.1	Plug	41
4.8.2	Pin allocation [X9] – 1-phase	41
4.8.3	Pin allocation [X9] – 3-phase	42
4.8.4	Mains fuse	43
4.8.5	AC supply	43
4.8.6	Braking resistor	45
4.9	Connection: Incremental encoder input [X10]	46
4.9.1	Plug [X10]	46
4.9.2	Pin assignment [X10]	46
4.9.3	Type and design of the cable [X10]	47
4.9.4	Connection instructions [X10]	47
4.10	Connection: Incremental encoder output [X11]	47
4.10.1	Plug [X11]	47
4.10.2	Pin assignment [X11]	47
4.11	FCT interfaces	48
4.11.1	Overview of interfaces	48
4.11.2	USB [X19]	48
4.11.3	Ethernet TCP/IP [X18]	49
4.12	Instructions on safe and EMC-compliant installation	51
4.12.1	Explanations and terms	51
4.12.2	General remarks on EMC	51
4.12.3	EMC areas: First and second environment	52
4.12.4	EMC-compliant wiring	52
4.12.5	Operation with long motor cables	54
4.12.6	ESD protection	54
5	Commissioning	55
5.1	General connection instructions	55
5.2	Tool / material	55
5.3	Connecting the motor	55
5.4	Connect motor controller CMMP-AS-...-M3 to the power supply	56
5.5	Connect the PC	56
5.6	Check operating status	57
6	Service functions and diagnostic messages	58
6.1	Protective and service functions	58
6.1.1	Overview	58
6.1.2	Phases and mains failure detection	58

6.1.3	Overload current and short-circuit monitoring	58
6.1.4	Overvoltage monitoring for the intermediate circuit	58
6.1.5	Temperature monitoring for the heat sink	58
6.1.6	Monitoring of the motor	59
6.1.7	I ² t monitoring	59
6.1.8	Power monitoring for the brake chopper	59
6.1.9	Commissioning status	60
6.1.10	Rapid discharge of the intermediate circuit	60
6.1.11	Detection of faults in conjunction with the functional safety engineering	60
6.2	Operating mode and diagnostic messages	60
6.2.1	Operation and display components	60
6.2.2	7-segment display	61
6.2.3	Acknowledgement of error messages	62
6.2.4	Diagnostic messages	62
7	Maintenance, care, repair and replacement	63
7.1	Maintenance and care	63
7.2	Repair	63
7.3	Replacement and disposal	63
7.3.1	Dismounting and installation	63
7.3.2	Disposal	63
A	Technical appendix	64
A.1	Technical data CMMP-AS-...-M3	64
A.1.1	Interfaces	72
A.2	Technical data CAMC-...	76
A.3	Supported encoders	77
B	Diagnostic messages	79
B.1	Explanations of the diagnostic messages	79
B.2	Diagnostic messages with instructions for fault clearance	80

Instructions on this documentation

This documentation is intended to help you safely work with the motor controller CMMP-AS-...-M3 and describes the mounting and installation processes.

Target group

This documentation is intended exclusively for technicians trained in control and automation technology, who have experience in installation, commissioning, programming and diagnostics of positioning systems.

Product identification, versions



This description refers to the following versions:

- Motor controller from Rev. 01
- FCT plug-in CMMP-AS from version 2.3.x.



Note

Before using a newer firmware version, check whether a newer version of the FCT plug-in or user documentation is available for it
 Support Portal: → www.festo.com/sp

Rating plate (example)	Meaning	
	Type designation	CMMP-AS-C2-3A-M3
	Part number	1501325
	Serial number	XX
	Revision status	Rev XX
	Input data	100 ... 230 V AC ±10%
		50 ... 60 Hz 3 A
	Output data	0 ... 270 V AC
		0 ... 1000 Hz 2.5 A
	Max. ambient temperature	40°C

Tab. 1 Rating plate example CMMP-AS-C2-3A-M3

Service

Please consult your regional Festo contact if you have any technical problems.

Specified standards/directives

Issue status	
2006/42/EC	EN 61326-1:2006-05
2006/95/EC	EN 50178:1997-10
2004/108/EC	EN 60204-1:2006-06
EN 61800-3:2004-12	IEC 61131-2:2007-09

Tab. 2 Standards/directives specified in the document

Production time period

On the type plate, the first 2 characters of the serial number indicate the production period in encrypted form (→ Tab. 1) The letter specifies the manufacturing year and the character behind it (number or letter) indicates the month of production.

Manufacturing year					
X = 2009	A = 2010	B = 2011	C = 2012	D = 2013	E = 2014
F = 2015	H = 2016	J = 2017	K = 2018	L = 2019	M = 2020

Tab. 3 Manufacturing year (20-year cycle)

Manufacturing month	
1	January
3	March
5	May
7	July
9	September
N	November
2	February
4	April
6	June
8	August
O	October
D	December

Tab. 4 Manufacturing month

Type codes

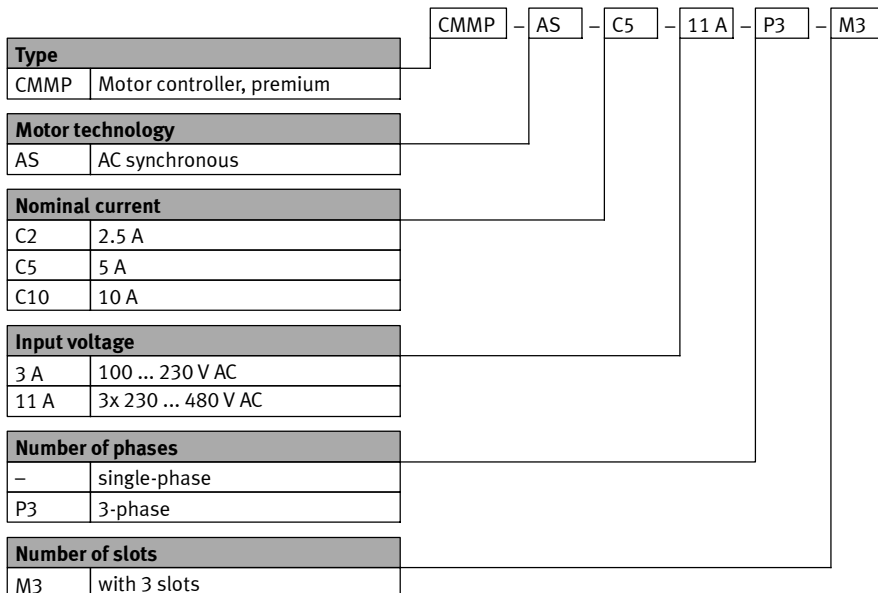

Fig. 1 Type codes

Documentation

You will find additional information on the motor controller in the following documentation:

User documentation on the motor controller CMMP-AS-...-M3	
Name, type	Table of contents
Hardware description, GDPC-CMMP-M3-HW-...	Mounting and installation of the motor controller CMMP-AS-...- M3 for all variants/output classes (1-phase, 3-phase), pin assignments, error messages, maintenance.
Function descriptions, GDPC-CMMP-M3-FW-...	Functional description (firmware) CMMP-AS-...- M3 , Instructions on commissioning.
Description FHPP, GDPC-CMMP-M3/-M0-C-HP-...	Control and parameterisation of the motor controller via the FHPP Festo profile. <ul style="list-style-type: none"> – Motor controller CMMP-AS-...-M3 with the following field-busses: CANopen, PROFINET, PROFIBUS, EtherNet/IP, DeviceNet, EtherCAT. – Motor controller CMMP-AS-...-M0 with fieldbus CANopen.
Description CiA 402 (DS 402), GDPC-CMMP-M3/-M0-C-CO-...	Control and parameterisation of the motor controller via the device profile CiA 402 (DS 402) <ul style="list-style-type: none"> – Motor controller CMMP-AS-...-M3 with the following field-busses: CANopen and EtherCAT. – Motor controller CMMP-AS-...-M0 with fieldbus CANopen.
Description CAM-Editor, P.BE-CMMP-CAM-SW-...	Cam disc function (CAM) of the motor controller CMMP-AS-...- M3/-M0 .
Description safety module, GDPC-CAMC-G-S1-...	Functional safety engineering for the motor controller with the safety function STO.
Description safety module, GDPC-CAMC-G-S3-...	Functional safety engineering for the motor controller with the safety functions STO, SS1, SS2, SOS, SBC, SLS, SSR, SSM.
Help for the FCT plug-in CMMP-AS	User interface and functions of the CMMP-AS plug-in for the Festo Configuration Tool → www.festo.com/sp .

Tab. 5 Documentation on the motor controller CMMP-AS-...-M3

1 Safety and requirements for product use

1.1 Safety

1.1.1 Safety instructions for commissioning, repair and de-commissioning



Warning

Danger of electric shock.

- When modules or cover plates are not mounted on the slots Ext1 ... Ext3.
- When cables are not mounted to the plugs [X6] and [X9].
- When connecting cables are disconnected when powered.

Touching live parts causes severe injuries and can lead to death.

The product may only be operated in a built-in status and when all safeguardings have been initiated.

Before touching live parts during maintenance, repair and cleaning work and when there have been long service interruptions:

1. Switch off power to the electrical equipment via the mains switch and secure it against being switched on again.
2. After switch-off, wait at least 5 minutes discharge time and check that power is turned off before accessing the controller.



The safety functions do not protect against electric shock but only against dangerous movements!



Note

Danger from unexpected movement of the motor or axis.

- Make sure that the movement does not endanger anyone.
- Perform a risk assessment in accordance with the EC machinery directive.
- Based on this risk assessment, design the safety system for the entire machine, taking into account all integrated components. This also includes the electric drives.
- Bypassing safety equipment is impermissible.

1.1.2 Protection against electric shock through protective extra-low voltage (PELV)



Warning

- Use for the electrical power supply only PELV circuits in accordance with IEC DIN EN 60204-1 (Protective Extra-Low Voltage, PELV). Also comply with the general requirements for PELV circuits laid down in IEC/DIN EN 60204-1.
- Use only power sources which guarantee reliable electrical disconnection of the operating voltage as per IEC/DIN EN 60204-1.

Protection against electric shock (protection against direct and indirect contact) is guaranteed in accordance with IEC/DIN EN 60204-1 through the use of PELV circuits (Electrical equipment of machines, general requirements).

1.1.3 Intended use

The CMMP-AS-...-M3. is intended for ...

- Use in control cabinets for power supply to AC servo motors and their regulation of torques (current), rotational speed and position.

The CMMP-AS-...-M3. is intended for installation in machines or automated systems and may be used only in the following ways:

- in excellent technical condition,
- in original status without unauthorised modifications,
- within the limits of the product defined by the technical data (→ Appendix A Technical appendix),
- in an industrial environment.



Note

In the event of damage caused by unauthorised manipulation or other than intended use, the guarantee is invalidated and the manufacturer is not liable for damages.

1.2 Requirements for product use

- Make this documentation available to the design engineer, installer and personnel responsible for commissioning the machine or system in which this product is used.
- Make sure that the specifications of the documentation are always complied with. Also consider the documentation for the other components and modules.
- Take into consideration the legal regulations applicable for the destination, as well as:
 - regulations and standards,
 - regulations of the testing organizations and insurers,
 - national specifications.

1.2.1 Transport and storage conditions

- Protect the product during transport and storage from impermissible burdens, such as:
 - mechanical loads,
 - impermissible temperatures,
 - moisture,
 - aggressive atmospheres.
- Store and transport the product in its original packaging. The original packaging offers sufficient protection from typical stresses.

1.2.2 Technical requirements

General conditions for the correct and safe use of the product, which must be observed at all times:

- Comply with the connection and environmental conditions specified in the technical data of the product (→ Appendix A) and of all connected components.
Only compliance with the limit values or load limits permits operation of the product in accordance with the relevant safety regulations.
- Observe the instructions and warnings in this documentation.

1.2.3 Qualification of the specialists (requirements for the personnel)

The product may only be placed in operation by a qualified electrotechnician who is familiar with:

- the installation and operation of electrical control systems,
- the applicable regulations for operating safety-engineered systems,
- the applicable regulations for accident protection and occupational safety, and
- the documentation for the product.

1.2.4 Range of application and certifications

Standards and test values, which the product complies with and fulfils, can be found in the “Technical data” section (→ Appendix A). The product-relevant EU directives can be found in the declaration of conformity.



Certificates and declaration of conformity on this product can be found at
→ www.festo.com/sp.

Certain configurations of the product have been certified by Underwriters Laboratories Inc. (UL) for the USA and Canada. These configurations bear the following mark:



UL Listing Mark for Canada and the United States



Note

Observe the following if the UL requirements are to be complied with in your application:

- Rules for observing the UL certification can be found in the separate UL special documentation. The technical data stated therein take priority.
- The technical data in this documentation may show values deviating from this.

2 Product overview

2.1 The entire system for the CMMP-AS-...-M3

A motor controller CMMP-AS-...-M3 entire system is shown in → Fig. 2.1 → Page 14. For operation of the motor controller, the following components are required:

- Mains power switch
- FI circuit breaker (RCD), all-current sensitive 300 mA
- Automatic circuit breaker
- Power supply 24 VDC
- Motor controller CMMP-AS-...-M3
- Motor with motor and encoder cables

A Windows PC with USB or Ethernet connection is required for parametrisation.



Observe the instructions regarding mains fuses in → Chapter 4.

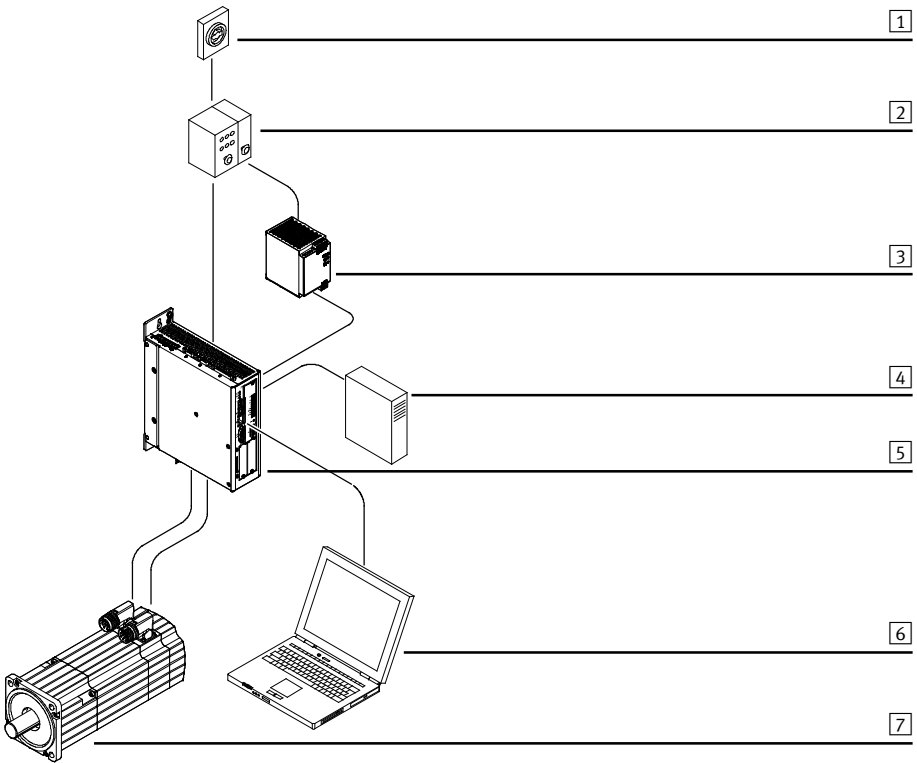

- | | | | |
|---|-------------------------------------|---|-----------------------------------|
| 1 | Power switch | 5 | Motor controller CMMP-AS-...-M3 |
| 2 | Fuse | 6 | PC |
| 3 | Power pack for logic voltage | 7 | Motor (e.g. EMMS-AS with encoder) |
| 4 | Optional: External braking resistor | | |

Fig. 2.1 Complete structure CMMP-AS-...-M3 with motor and PC

2.2 Scope of delivery

The delivery includes:

Scope of delivery	
Motor controller	CMMP-AS-...-M3
Operator package	CD
	Brief description
Assortment of plugs	NEKM-C-7

Tab. 2.1 Scope of delivery

2.3 Device view

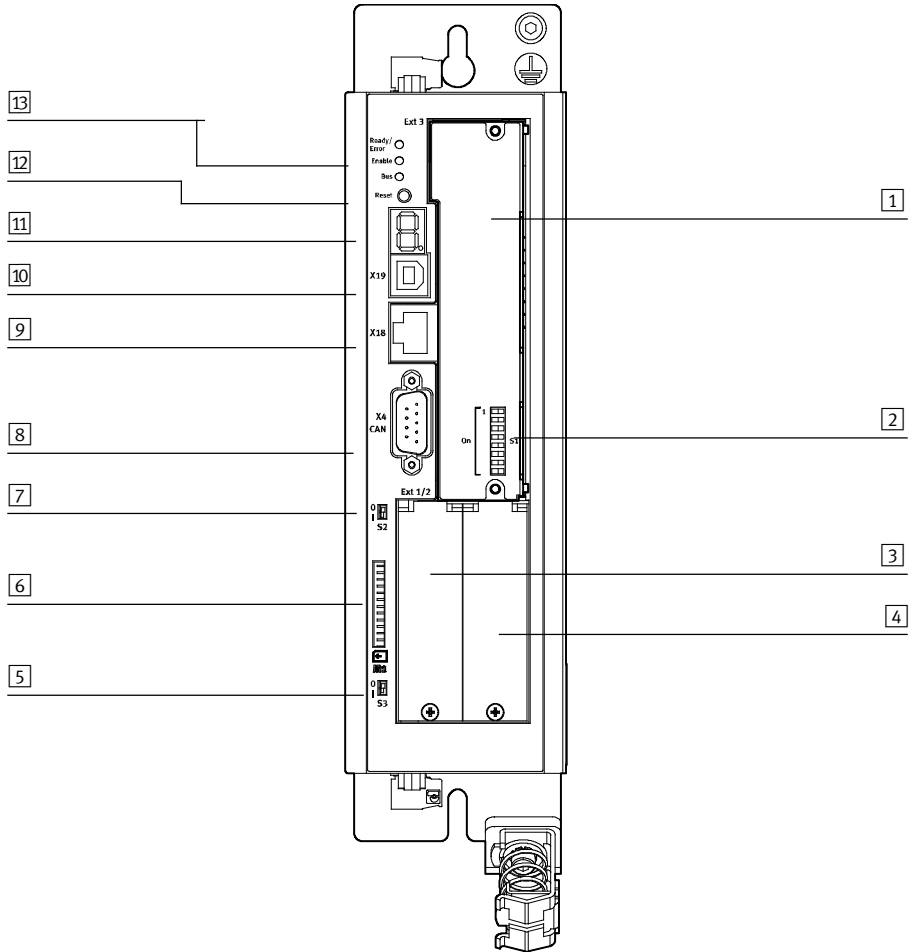

- | | |
|---|---|
| <ul style="list-style-type: none"> 1 Slot for switch or safety module [Ext3] 2 Fieldbus settings [S1] 3 Slot for extension modules [Ext1] 4 Slot for extension modules [Ext2] 5 Activation of firmware download [S3] 6 SD-/MMC card slot [M1] | <ul style="list-style-type: none"> 7 Activation of CANopen terminating resistor [S2] 8 CANopen interface [X4] 9 Ethernet interface [X18] 10 USB interface [X19] 11 7-segment display 12 Reset button 13 LEDs |
|---|---|

Fig. 2.2 Motor controller CMMP-AS-...-M3: Front view

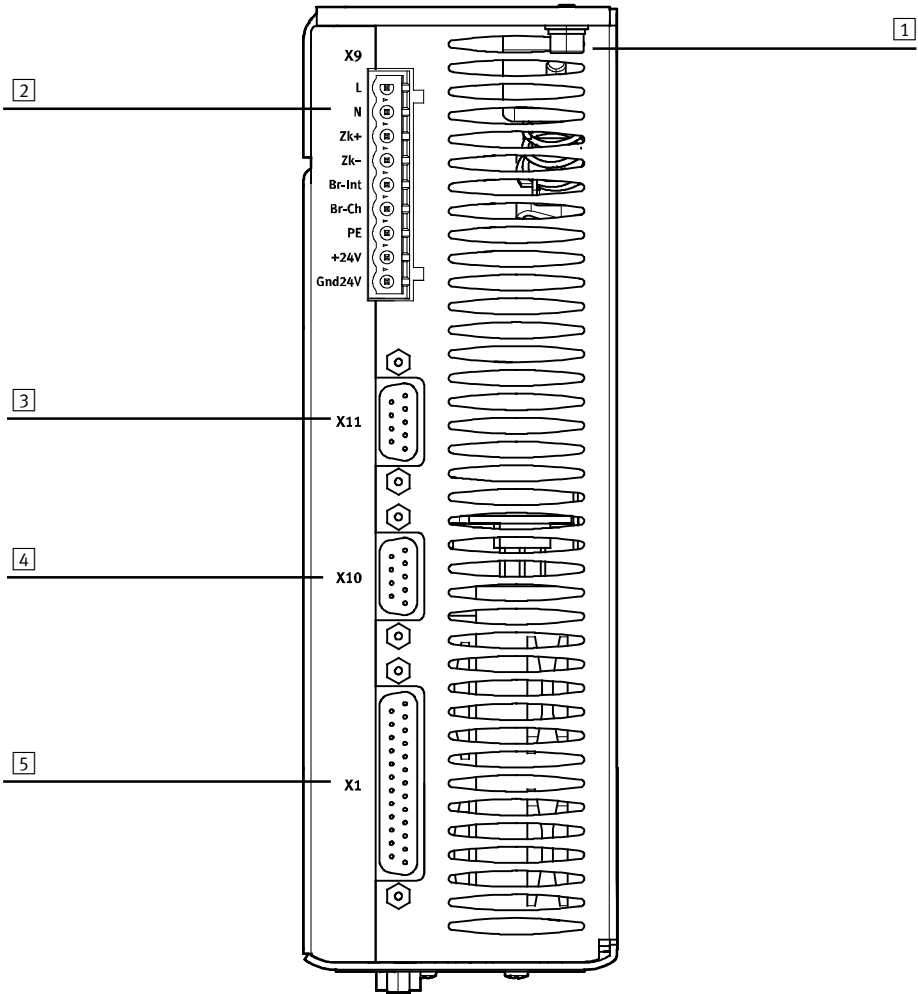

- | | |
|---|--|
| 1 PE connection | 4 Incremental encoder input [X10] |
| 2 Power supply [X9] | 5 I/O communication [X1] |
| 3 Incremental encoder output [X11] | |

Fig. 2.3 Motor controller CMMP-AS-...-3A-M3: Top view

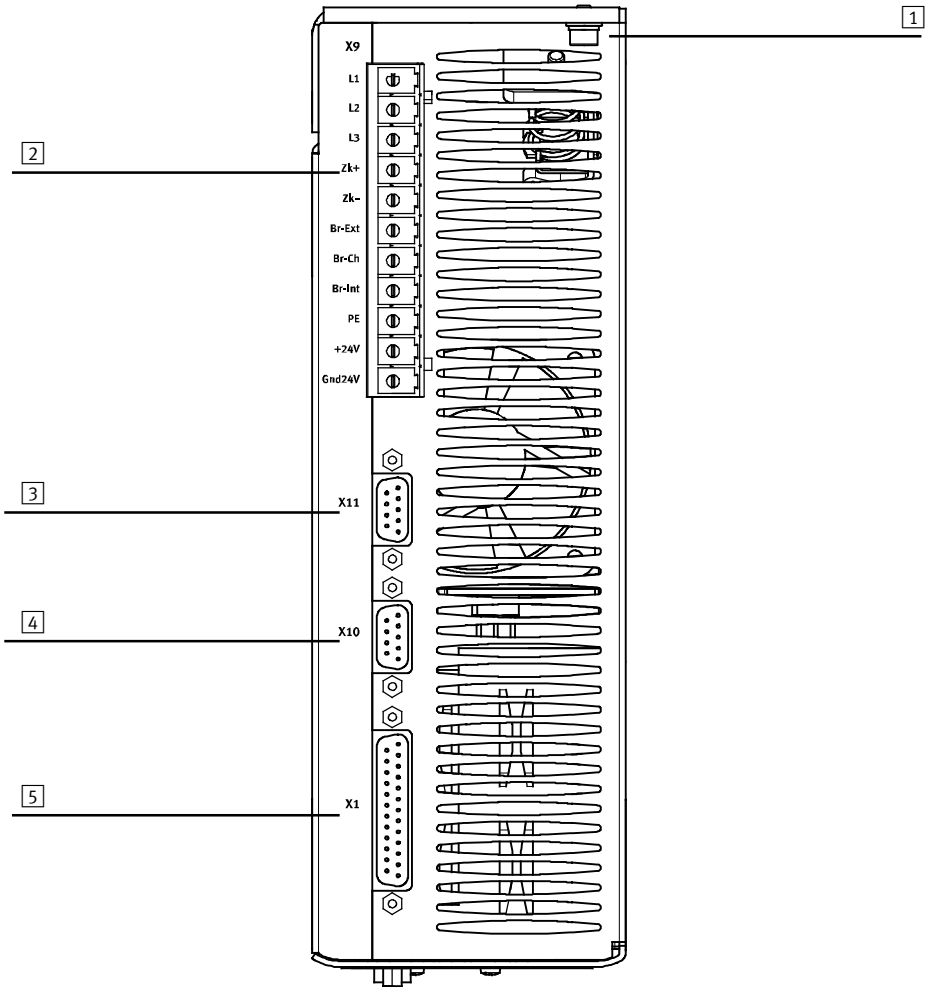

- | | |
|---|--|
| 1 PE connection | 4 Incremental encoder input [X10] |
| 2 Power supply [X9] | 5 I/O communication [X1] |
| 3 Incremental encoder output [X11] | |

Fig. 2.4 Motor controller CMMP-AS....11A-P3-M3: Top view

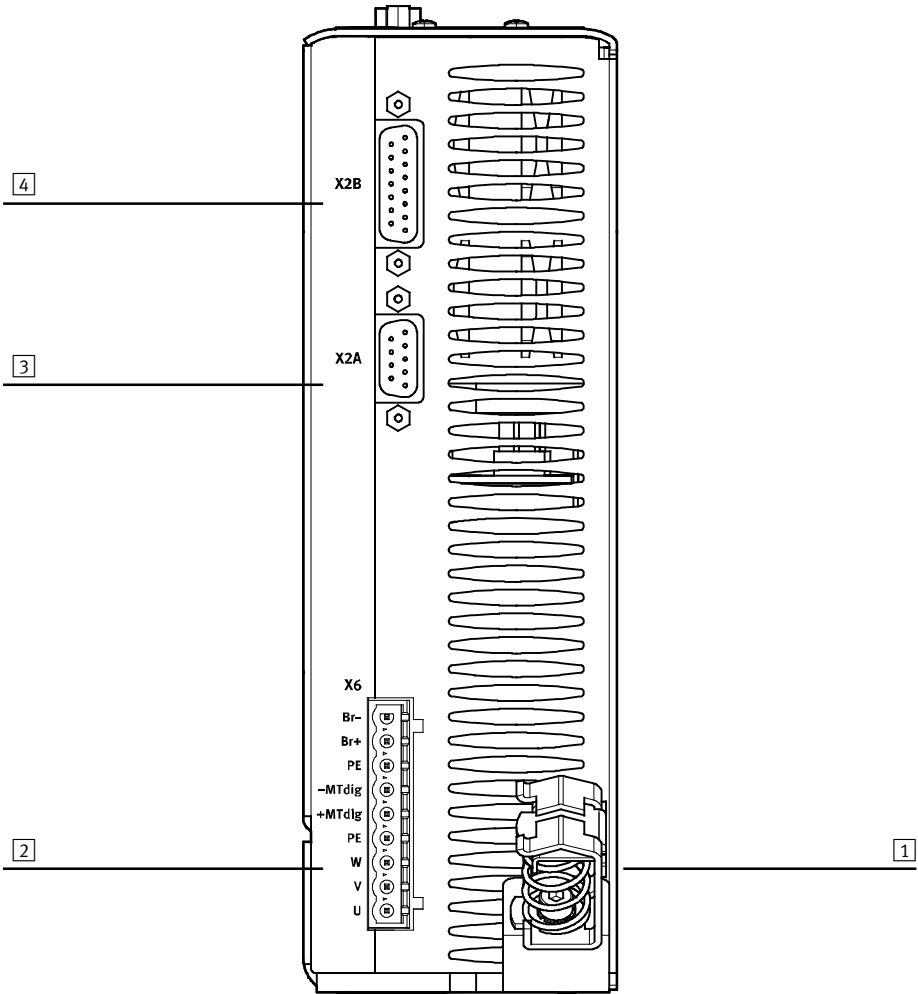

- 1 Spring-loaded terminal connection for the outer shield of the motor cable
- 2 Motor connection [X6]
- 3 Connection for the resolver [X2A]
- 4 Connection for the encoder [X2B]

Fig. 2.5 Motor controller CMMP-AS-...-M3: Bottom view

3 Mechanical installation

3.1 Important instructions



Note

Proceed carefully when mounting. During mounting and subsequent operation of the drive, ensure that that no metal shavings, metal dust or mounting parts (screws, nuts, pieces of wire) fall into the motor controller.



Note

The motor controllers CMMP-AS-...-M3

- Use only as installed devices for control cabinet mounting.
- Mounting orientation with the power supply [X9] on top.
- Mount it with the clip on the mounting plate.
- Mounting clearance:
For sufficient ventilation, 100 mm of clearance to other sub-assemblies is required above and below the device.
- An installation clearance of 150 mm underneath the device is recommended for optimum wiring of the motor or encoder cable!
- The motor controllers of the CMMP-AS-...-M3 family are designed so that they can be mounted on a heat-dissipating mounting plate if used as intended and installed correctly. We wish to point out that excessive heating can lead to premature aging and/or damage to the device. With high thermal stress on the motor controller CMMP-AS-...-M3, a mounting distance (→ Fig. 3.4) is recommended!

3.2 Mounting



Observe the safety instructions → Chapter 1 during mounting and installation work.



Note

Damage to the interface or motor controller due to incorrect handling.

- Switch off the supply voltage before mounting and installation work. Switch on supply voltage only when mounting and installation work are completely finished.
- Never unplug modules from the motor controller or plug them in when powered!
- Observe the handling specifications for electrostatically sensitive devices. Do not touch the printed circuit board and the pins of the manifold rail in the motor controller. Grip the interface only on the front panel or on the edge of the board.



3.2.1 Module in slot Ext3

The motor controllers CMMP-AS-...-M3 are supplied without a module in slot Ext3; the slot is covered with foil.



To operate the motor controller, an appropriate module must be mounted in slot Ext3:

- Micro switch module CAMC-DS-M1 or
- Safety module CAMC-G-S...

Mounting the module

1. Slide the module into the guides.
 2. Tighten the screws. Observe tightening torque $0.4 \text{ Nm} \pm 20\%$.
- Result: Front plate has conducting contact with the housing.

Remove module

1. Unscrew screws.
2. Loosen the module by gently levering the front cover or by pulling on the counterplug by a few millimetres and pull it out of the slot.

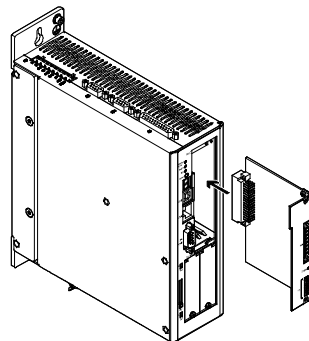

Fig. 3.1 Mounting / dismantling

DIL switches

The eight switches on the plug-in modules (Ext3) are designed as DIL switches.

The status of the DIL switches is read when the control voltage is switched on or upon RESET. The motor controller takes over changes to the switch setting in ongoing operation only at the next switch-on or RESET.



The significance of the DIL switch setting depends on the control interface used.

DIL switch	CANopen/DriveBus	DeviceNet	PROFIBUS	PROFINET	Ethernet/IP	EtherCAT
	Onboard	CAMC-DN plugged in	CAMC-PB plugged in	CAMC-F-PN plugged in	CAMC-F-EP plugged in	CAMC-EC plugged in
1	NN bit 0	NN bit 0	NN bit 0	Not used		
2	NN bit 1	NN bit 1	NN bit 1	Not used		
3	NN bit 2	NN bit 2	NN bit 2	Not used		
4	NN bit 3	NN bit 3	NN bit 3	Not used		
5	NN bit 4	NN bit 4	NN bit 4	Not used		
6	Bit rate	Bit rate	NN bit 5	Not used		
7	Bit rate	Bit rate	NN bit 6	Not used		
8	Activation of fieldbus					
NN = node number						

Tab. 3.1 Setting of bit rate and node number

DIL switch	1 Mbit/s ¹⁾	500 kBit/s	250 kBit/s	125 kBit/s
6	On	Off	ON	Off
7	ON	ON	Off	Off

1) Only for CANopen/DriveBus; for DeviceNet, is limited to 500 kBit/s

Tab. 3.2 Setting of bit rate for CANopen and DeviceNet

DIL switch 8	Fieldbus
1	always activated
0	always off

Tab. 3.3 Activation of the fieldbus



With DIL switch 8, the fieldbus of the plugged-in interface CAMC-... is activated. If no interface is plugged in, the CAN bus [X4] is activated.

3.2.2 Interface in slot Ext1 or Ext2 (optional)

The motor controllers CMMP-AS-...-M3 are shipped without interfaces in the slots Ext1 and Ext2; the slots are sealed with covers.

Through the interfaces, the motor controller can be extended by digital I/Os and/or fieldbus interfaces.

Tab. 3.4 shows the permissible slots for the interfaces.

Slot	Interface					
	CAMC-F-PN	CAMC-PB	CAMC-F-EP	CAMC-DN	CAMC-EC	CAMC-D-8E8A
Ext1	-1)	-1)	-1)	x	-1)	x
Ext2	x	x	x	-1)	x	x

1) In addition, CAMC-D-8E8A permissible

Tab. 3.4 Permissible slots Ext1 and Ext2 for the interfaces

Mounting the interface

1. Unscrew screw [1].
2. Lever out cover [2] to the side. Use a small screwdriver.
3. Slide interface [3] into the guides.
4. Tighten screw [1]. Observe tightening torque 0.4 Nm ± 20%.
Result: Front plate has conducting contact with the housing.

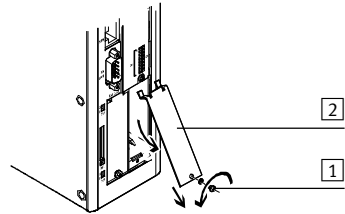

Dismantle interface

1. Unscrew screw [1].
2. Lever out interface [2] to the side. Use a small screwdriver.
3. Pull interface [3] out of the slot.
4. Mount another interface or cover.

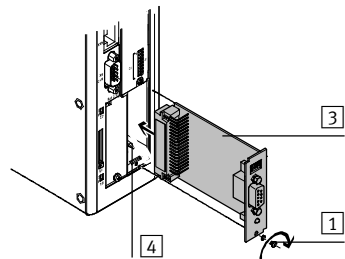

Fig. 3.2 Mounting or dismantling (example CAMC-PB)

3.2.3 Motor controller

At the motor, controller CMMP-AS-...-M3, there are mounting clips at the top and bottom of the device. They are used to attach the motor controller vertically to a mounting plate. The clips are part of the radiator profile, ensuring an optimal heat transfer to the mounting plate.



Please use size M5 screws to attach the motor controller CMMP-AS-...-M3.

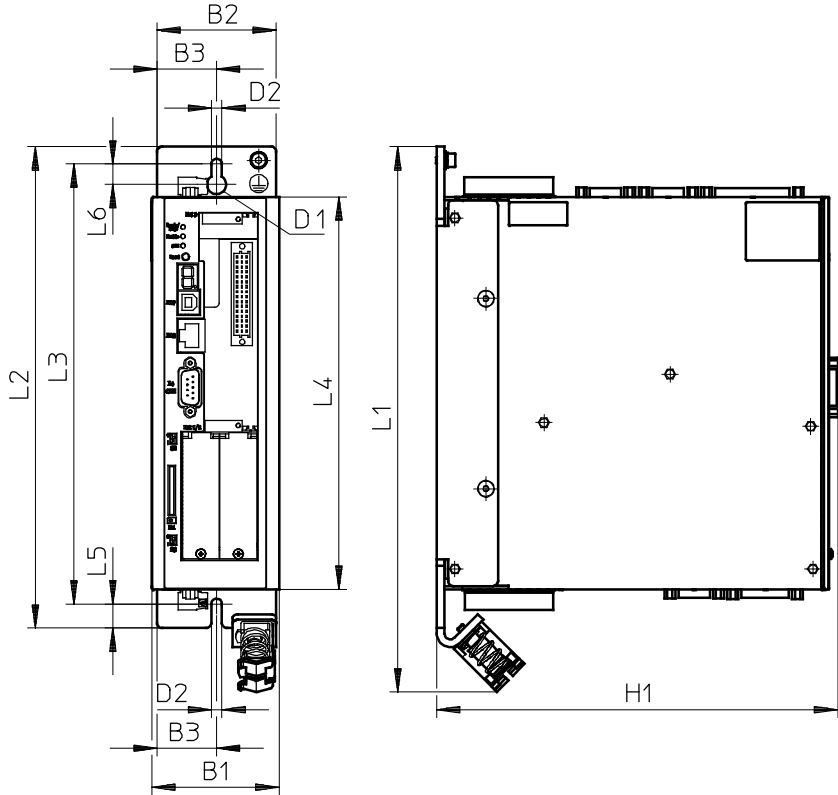

Fig. 3.3 Motor controller CMMP-AS-...-M3: Mounting plate

CMMP-AS-...		H1	L1	L2	L3	L4	L5	L6	B1	B2	B3	D1	D2
-3A-M3	[mm]	207	281	248	227	202	12.5	10.5	66	61	30.7	10	5.5
-11A-P3-M3	[mm]	247	330	297	276	252	12.5	10.5	79	75	37.5	10	5.5

Tab. 3.5 Motor controller CMMP-AS-...-M3: Dimensions table

3 Mechanical installation

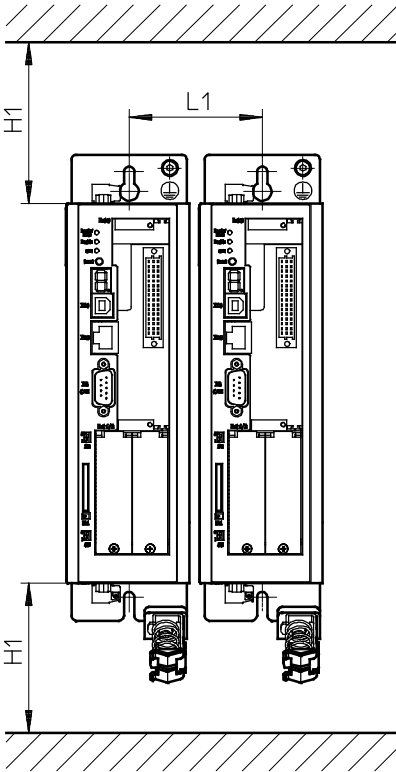

Fig. 3.4 Motor controller CMMP-AS-...-M3: Mounting distance and installation clearance

Motor controller		L1	H1 ¹⁾
CMMP-AS-...-3A-M3	[mm]	71	100
CMMP-AS-...-11A-P3-M3	[mm]	85	100

1) An installation clearance of 150 mm underneath the device is recommended for optimum wiring of the motor or encoder cable!

Tab. 3.6 Motor controller CMMP-AS-...-M3: Mounting distance and installation clearance

4 Electrical installation

4.1 Safety instructions



Warning

Danger of electric shock

Motor controllers are devices with increased leakage current ($> 3.5 \text{ mA}$). If wiring is incorrect or the device is defective, high voltage can occur on the housing, which can result in serious injury or even death if the housing is touched.

- Before commissioning, also for brief measuring and test purposes, connect the PE protective conductor:
 - to the earthing screw of the controller housing
 - to pin PE [X9], power supply.

The cross section of the protective conductor at PE [X9] must correspond at least to the cross section of the external conductor L [X9].

- Observe the regulations of EN 60204-1 for the protective earthing.



Warning

Danger of electric shock

- when the module or cover plate is not mounted on the card slot [EXT]
- when cables are not mounted to the plugs [X6] and [X9]
- if connecting cables are disconnected when powered.

Touching live parts causes severe injuries and can lead to death. Before mounting and installation work:

1. Switch off power to the electrical equipment via the mains switch and secure it against being switched on again.
2. After switch-off, wait at least 5 minutes discharge time and check that power is turned off before accessing the controller.



Warning

Danger of electric shock

This product can cause a DC current in the protective ground conductor. In cases where an error current protection unit (RCD) or an error current monitoring device (RCM) is used to protect against direct or indirect contact, only the Type B kind of RCD or RCM is permitted on the power supply side of this product.





Caution

Danger from unexpected movement

Faulty pre-mounting lines may destroy the electronics and trigger unexpected movements of the motor.

- When wiring the system, use only the supplied plug connectors and preferably the cables listed in the catalogue as accessories.
→ www.festo.com/catalogue
- Lay all flexible lines so that they are free of kinks and free of mechanical stress; if necessary use chain link trunking.



Note

ESD (electrostatic discharge) can cause damage to the device or other system parts at plug connectors that are not used.

- Before installation: Earth the system parts and use appropriate ESD equipment (e.g. shoes, earthing straps etc.).
- After installation: Seal unassigned Sub-D plug connectors with protective caps (available at authorized dealers).
- Observe the handling specifications for electrostatically sensitive devices.



4.2 Allocation of the plug connectors

The motor controller CMMP-AS-...-M3 is connected to the supply voltage, the motor, the external braking resistor and the holding brake in accordance with the following circuit diagrams.

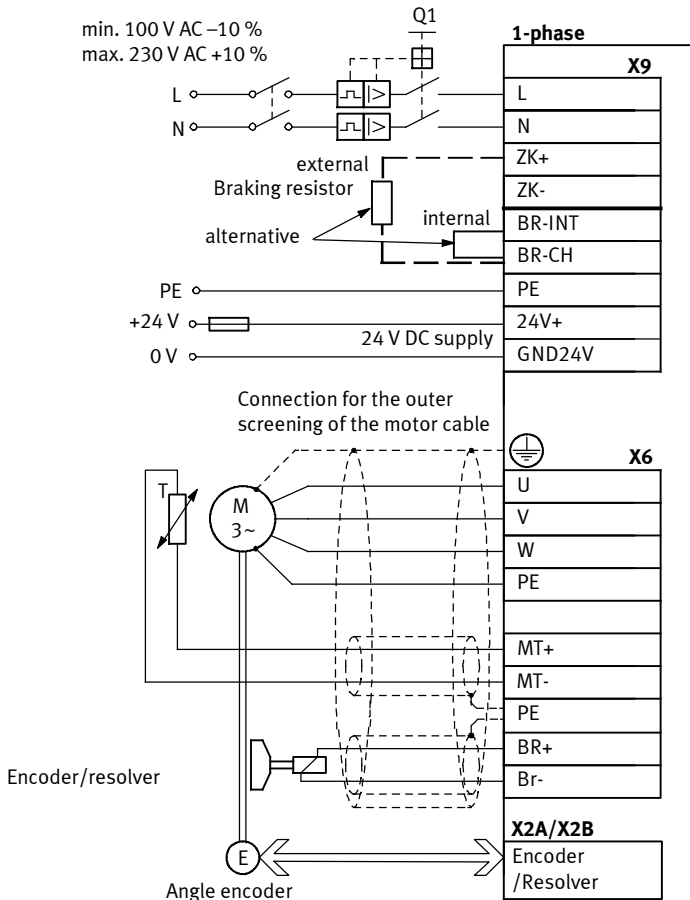

Fig. 4.1 CMMP-AS-...-3A-M3: Single-phase connection to the supply voltage and the motor

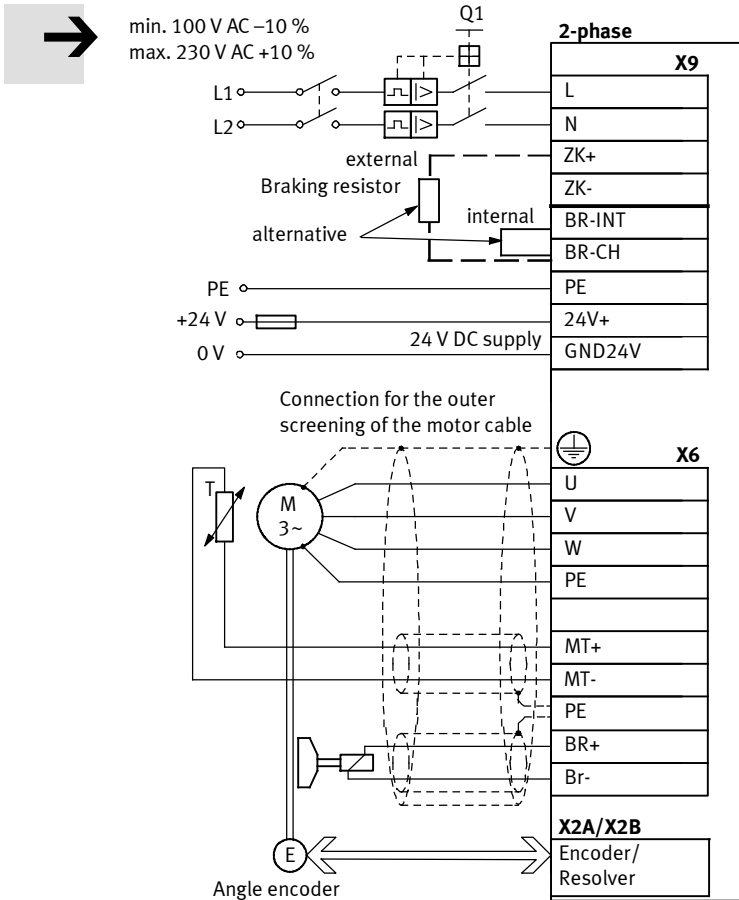

Fig. 4.2 CMMP-AS-...-3A-M3: Dual-phase connection L1/L2 to the supply voltage and the motor

Note

The **maximum voltage** of 230 V AC +10 % must be present between the **external conductors**.

In typical European low voltage networks that have a nominal star voltage of 230 V, a mesh voltage of approx. 400 V develops between two external conductors, which could result in damage to the motor controller!

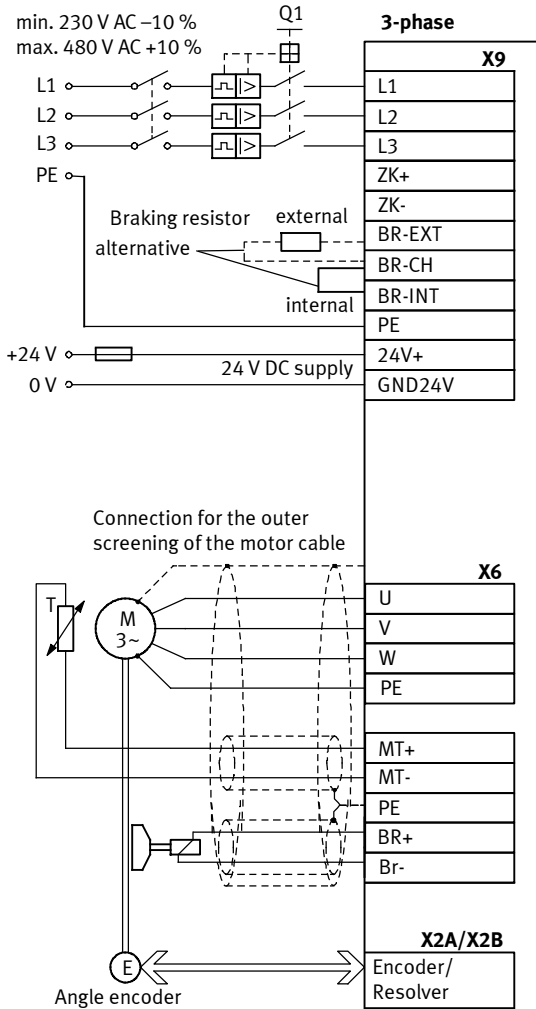

Fig. 4.3 CMMP-AS-...-11A-M3: Triple-phase connection to the supply voltage and the motor

The power supply cables for the power end stage are alternatively connected to the following terminals:

Port		
Supply (Observe instructions in chapter → 4.8.5)		
AC supply	L, N	for single-phase motor controllers
	L1, L2, L3	for three-phase motor controllers
DC supply	ZK+, ZK-	
Motor temperature switch		
PTC or N/C contact/ N/O contact (e.g. KTY81)	MT+, MT-; [X6]	if this is carried together with the motor phases in one cable
Analogue temperature sensor	MT+, MT-; [X2A] or [X2B]	–

Tab. 4.1 Connection of power supply cables



Note

Temperature sensors must be sufficiently isolated from the motor winding.

The connection of the encoder via the Sub-D plug connector to [X2A] or [X2B] is roughly shown diagrammatically in → Fig. 4.1, → Fig. 4.2 and → Fig. 4.3.



Note

If the polarity of the operating voltage connections is reversed, or if the operating voltage is too high or the operating voltage and motor connections are reversed, the motor controller CMMP-AS-...-M3 will be damaged.

4.3 Connection: I/O communication [X1]

4.3.1 Plug [X1]

Motor controller	Design on the device	Counterplug
CMMP-AS-...-M3	Sub-D plug connector, 25-pin, socket	Sub-D plug connector, 25-pin, pins

Tab. 4.2 Plug design [X1]

4.3.2 Pin assignment [X1]

See Technical data → section A.1.1 for connected loads of the inputs and outputs.

The standard assignment of the I/O interface in the firmware factory setting (delivery status) corresponds to → Tab. 4.3.

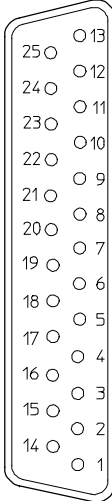
[X1]	Pin no.	Designation	Specification
	13	DOUT3	Output freely parameterisable, optionally parameterisable as DIN11
	25	DOUT2	Output freely parameterisable, optionally parameterisable as DIN10
	12	DOUT1	Output freely parameterisable
	24	DOUT0	Controller ready, output permanently assigned
	11	DIN 9	High-speed input can be parameterised freely
	23	DIN 8	Start positioning task, input can be freely parameterised
	10	DIN7	Limit switch 1 (blocks n < 0), input permanently assigned
	22	DIN6	Limit switch 0 (blocks n > 0), input permanently assigned
	9	DIN5	Controller enable, input permanently assigned
	21	DIN4	End stage enable, input permanently assigned
	8	DIN 3	Position selector bit 3, input freely parameterisable
	20	DIN 2	Position selector bit 2, input freely parameterisable
	7	DIN 1	Position selector bit 1, input freely parameterisable
	19	DIN 0	Position selector bit 0, input freely parameterisable
	6	GND24	Reference potential for digital I/Os
	18	+24 V	24 V output
	5	AOUT1	Analogue output freely parameterisable
	17	AOUT0	Analogue output freely parameterisable
	4	+VREF	Reference output for setpoint potentiometer
	16	AIN2	Setpoint input 2, single ended analogue input, optionally parameterisable as DIN13
	3	AIN1	Setpoint input 1, single ended analogue input, optionally parameterisable as DIN12
	15	#AIN0	Setpoint input 0, differential analogue input
	2	AIN0	
	14	AGND	Reference potential for analogue signals
	1	AGND	Screening for analogue signals, AGND

Tab. 4.3 Pin assignment: I/O communication [X1] (firmware factory setting)

The standard assignment of the I/O interface in the FCT corresponds to → Tab. 4.4.

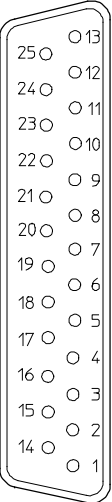
[X1]	Pin no.	Designation	Specification
	13	DOUT3	Following error, output freely parameterisable, optionally parameterisable as DIN11
	25	DOUT2	Brake unlocked, output freely parameterisable, optionally parameterisable as DIN10
	12	DOUT1	Motion Complete, output freely parameterisable
	24	DOUT0	Controller ready, output permanently assigned
	11	DIN 9	Flying measurement (sample)/reference switch, input freely parameterisable
	23	DIN 8	Start positioning task, input freely parameterisable
	10	DIN7	Limit switch 1 (blocks n < 0), input permanently assigned
	22	DIN6	Limit switch 0 (blocks n > 0), input permanently assigned
	9	DIN5	Controller enable, input permanently assigned
	21	DIN4	End stage enable, input permanently assigned
	8	DIN 3	Position selector bit 3, input freely parameterisable
	20	DIN 2	Position selector bit 2, input freely parameterisable
	7	DIN 1	Position selector bit 1, input freely parameterisable
	19	DIN 0	Position selector bit 0, input freely parameterisable
	6	GND24	Reference potential for digital I/Os
	18	+24 V	24 V output
	5	AOUT1	Position setpoint value, analogue output freely parameterisable
	17	AOUT0	Speed setpoint value, analogue output freely parameterisable
	4	+VREF	Reference output for setpoint potentiometer
	16	AIN2	Setpoint input 2, single ended analogue input, optionally parameterisable as DIN13
	3	AIN1	Setpoint input 1, single ended analogue input, optionally parameterisable as DIN12
	15	#AIN0	Setpoint input 0, differential analogue input
	2	AIN0	
	14	AGND	Reference potential for analogue signals
	1	AGND	Screening for analogue signals, AGND

Tab. 4.4 Pin assignment: I/O communication [X1] (FCT factory setting)

Controller

CMMP-AS-...-M3

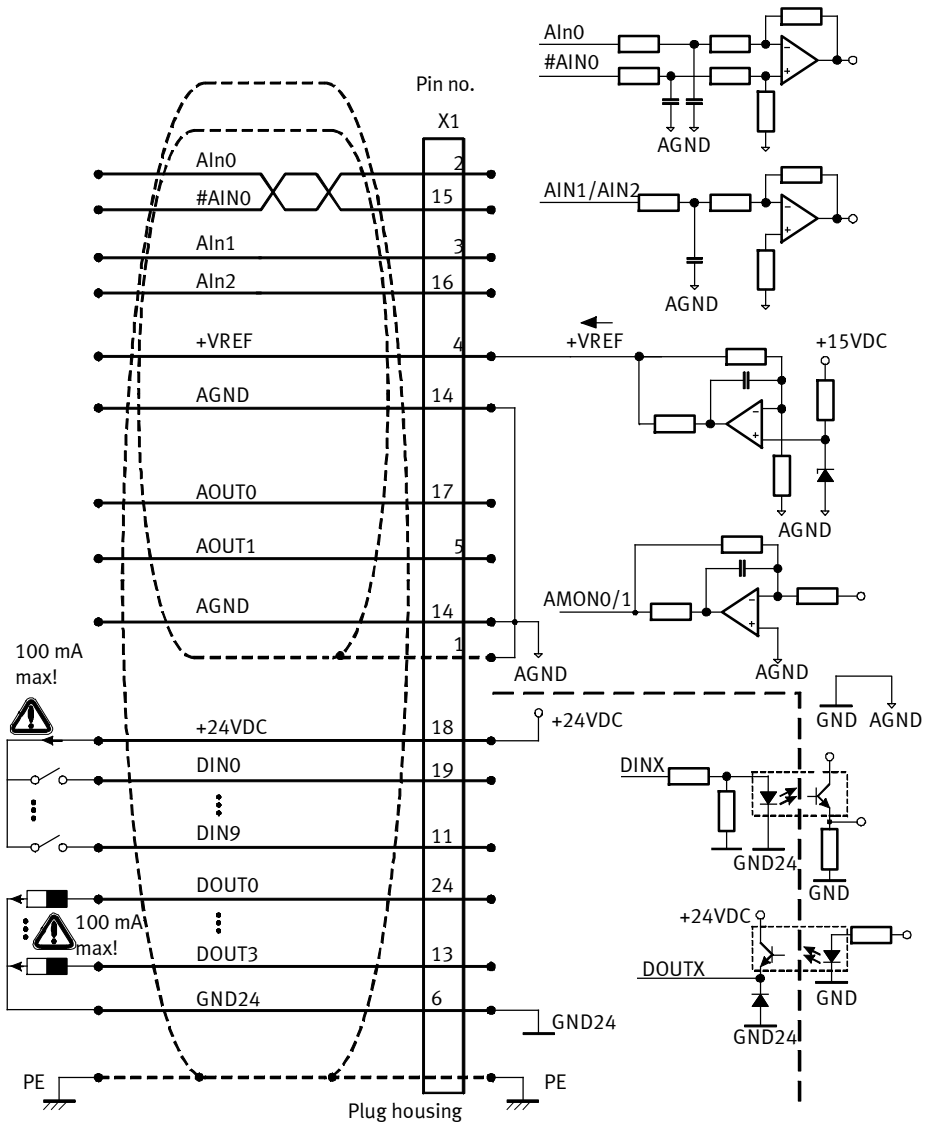

Fig. 4.4 Basic circuit diagram of connection [X1]



Control cable and Sub-D plug → www.festo.com/catalogue.

4.4 Connection: Resolver [X2A]

4.4.1 Plug [X2A]

Motor controller	Design on the device	Counterplug
CMMP-AS-...-M3	Sub-D plug connector, 9-pin, socket	Sub-D plug connector, 9-pin, pins

Tab. 4.5 Plug design [X2A]

4.4.2 Pin assignment [X2A]

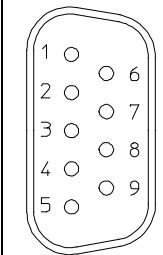
[X2A]	Pin no.	Designation	Value	Specification
	1	S2	3.5 V _{eff} 5-10 kHz R _i > 5 kΩ	SINE tracking signal, differential
	6	S4		
	2	S1	3.5 V _{eff} 5-10 kHz R _i > 5 kΩ	COSINE tracking signal, differential
	7	S3		
	3	AGND	0 V	Screening for signal pairs (inner screening)
	8	MT-	GND	Reference potential for temperature sensor
	4	R1	7 V _{eff} 5-10 kHz I _A ≤ 150 mA _{eff}	Carrier signal for resolver
	9	R2	GND	
	5	MT+	+3.3 V R _i = 2 kΩ	Temperature sensor, motor temperature, N/C contact, PTC, KTY ...

Tab. 4.6 Pin assignment [X2A]

The outer screening must always be connected to the PE (plug housing) of the motor controller.
The inner screenings must be placed on one side on the motor controller CMMP-AS-...-M3 on PIN3 of [X2A].

4.5 Connection: Encoder [X2B]

4.5.1 Plug [X2B]

Motor controller	Design on the device	Counterplug
CMMP-AS-...-M3	Sub-D plug connector, 15-pin, socket	Sub-D plug connector, 15-pin, pins

Tab. 4.7 Plug design [X2B]

4.5.2 Pin assignment [X2B]

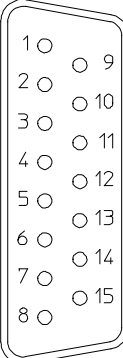
[X2B]	Pin no.	Designation	Value	Specification
	1	MT+	+3.3 V $R_I = 2 \text{ k}\Omega$	Temperature sensor, motor temperature, N/C contact, PTC, KTY ...
	9	U_SENS+	5 V ... 12 V	Sensor cable for the encoder supply
	2	U_SENS-	$R_I \approx 1 \text{ k}\Omega$	
	10	US	5 V/12 V $\pm 10\%$ $I_{\max} = 300 \text{ mA}$	Operating voltage for high-resolution incremental encoder
	3	GND	0 V	Reference potential of encoder power supply and motor temperature sensor
	11	R	0.2 V_{SS} ... 0.8 V_S	Zero impulse tracking signal (differential) from high-resolution incremental encoder
	4	R#	$R_I \approx 120 \Omega$	
	12	COS_Z1 ¹⁾	1 V_{SS}	COSINE commutation signal (differential) from high-resolution incremental encoder
	5	COS_Z1# ¹⁾	$R_I \approx 120 \Omega$	
	13	SIN_Z1 ¹⁾	1 V_{SS}	SINE commutation signal (differential) from high-resolution incremental encoder
	6	SIN_Z1# ¹⁾	$R_I \approx 120 \Omega$	
	14	COS_Z0 ¹⁾	1 $V_{SS} \pm 10\%$	COSINE tracking signal (differential) from high-resolution incremental encoder
	7	COS_Z0# ¹⁾	$R_I \approx 120 \Omega$	
	15	SIN_Z0 ¹⁾	1 $V_{SS} \pm 10\%$	SINE tracking signal (differential) from high-resolution incremental encoder
	8	SIN_Z0# ¹⁾	$R_I \approx 120 \Omega$	

1) Heidenhain encoder: A=SIN_Z0; B=COS_Z0; C=SIN_Z1; D=COS_Z1

Tab. 4.8 Pin assignment: Analogue incremental encoder – optional

The outer screening must always be connected to the PE (plug housing) of the motor controller.

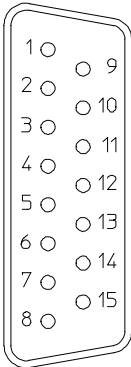
[X2B]	Pin no.	Designation	Value	Specification
	1	MT+	+3.3 V $R_i = 2\text{ k}\Omega$	Temperature sensor, motor temperature, N/C contact, PTC, KTY ...
	9	U_SENS+	5 V ... 12 V	Sensor cable for the encoder supply
	2	U_SENS-	$R_i \approx 1\text{ k}\Omega$	
	10	US	5 V/12 V $\pm 10\%$ $I_{\max} = 300\text{ mA}$	Operating voltage for high-resolution incremental encoder
	3	GND	0 V	Reference potential of encoder power supply and motor temperature sensor
	11	–		
	4	–		
	12	DATA	5 V _{SS}	Bidirectional RS485 data cable (differential)
	5	DATA#	$R_i \approx 120\ \Omega$	
	13	SCLK	5 V _{SS}	RS485 clock output (differential)
	6	SCLK#	$R_i \approx 120\ \Omega$	
	14	COS_Z0 ¹⁾	1 V _{SS} $\pm 10\%$ $R_i \approx 120\ \Omega$	COSINE tracking signal (differential) from high-resolution incremental encoder
	7	COS_Z0 ¹⁾ #		
	15	SIN_Z0 ¹⁾	1 V _{SS} $\pm 10\%$ $R_i \approx 120\ \Omega$	SINE tracking signal (differential) from high-resolution incremental encoder
	8	SIN_Z0 ¹⁾ #		

1) Heidenhain encoder: A=SIN_Z0; B=COS_Z0

Tab. 4.9 Pin assignment: Incremental encoder with serial interface, e.g. EnDat – optional

The outer screening must always be connected to the PE (plug housing) of the motor controller.

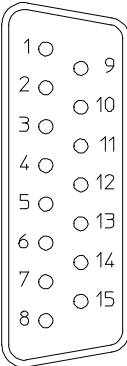
[X2B]	Pin no.	Designation	Value	Specification
	1	MT+	+3.3 V $R_I = 2 \text{ k}\Omega$	Temperature sensor, motor temperature, N/C contact, PTC, KTY ...
	9	U_SENS+	5 V ... 12 V	Sensor cable for the encoder supply
	2	U_SENS-	$R_I \approx 1 \text{ k}\Omega$	
	10	US	5 V/12 V / $\pm 10\%$ $I_{\text{max}} = 300 \text{ mA}$	Operating voltage for high-resolution incremental encoder
	3	GND	0 V	Reference potential of encoder power supply and motor temperature sensor
	11	N	2 V_{SS} ... 5 V_{SS}	Zero impulse RS422 (differential) from digital incremental encoder
	4	N#	$R_I \approx 120 \Omega$	
	12	H_U	0V/5V $R_I \approx 2 \text{ k}\Omega$	Phase U Hall sensor for commutation
	5	H_V	at VCC	Phase V Hall sensor for commutation
	13	H_W		Phase W Hall sensor for commutation
	6	–		
	14	A	2 V_{SS} ... 5 V_{SS} $R_I \approx 120 \Omega$	A tracking signal RS422 (differential) from digital incremental encoder
	7	A#		
	15	B	2 V_{SS} ... 5 V_{SS}	B tracking signal RS422 (differential) from digital incremental encoder
	8	B#	$R_I \approx 120 \Omega$	

Tab. 4.10 Pin assignment: Digital incremental encoder – optional

The outer screening must always be connected to the PE (plug housing) of the motor controller.

4.6 Connection: CAN bus [X4]

4.6.1 Plug [X4]

Motor controller	Design on the device	Counterplug
CMMP-AS-...-M3	Sub-D plug connector, 9-pin, pin	Sub-D plug connector, 9-pin, socket

Tab. 4.11 Plug design [X4]

4.6.2 Pin assignment [X4]

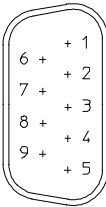
[X4]	Pin no.	Designation	Value	Description
	1	–	–	Not assigned
	6	CAN-GND	–	galvanically connected to GND in the motor controller
	2	CAN-L	–	Negative CAN signal (dominant low)
	7	CAN-H	–	Positive CAN signal (dominant high)
	3	CAN-GND	–	galvanically connected to GND in the motor controller
	8	–	–	Not assigned
	4	–	–	Not assigned
	9	–	–	Not assigned
	5	CAN shield	–	Screening

Tab. 4.12 Pin assignment for CAN-interface [X4]

4.7 Connection: Motor [X6]

4.7.1 Plug [X6]

CMMP-AS-...	Design on the device / coding		Counterplug / coding	
...C2-3A-M3	PHOENIX Contact	Pin 1 (BR-)	PHOENIX Contact	Pin 9 (U)
...C5-3A-M3	MSTBA 2.5/9-G-5.08 BK		MSTB 2.5/9-ST-5.08 BK	
...11A-P3-M3	PHOENIX Power-Combicon	-	PHOENIX Power-Combicon	-
...C10-11A-P3-M3	PC 5/9-G-7.62 BK		PC 5/9-ST-7.62 BK	

Tab. 4.13 Plug design [X6]

4.7.2 Pin assignment [X6]

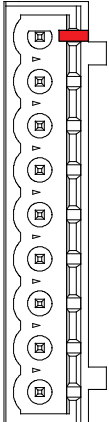
[X6] ¹⁾	Pin no.	Designation	Value	Specification
	1	Br-	0 V brake	Holding brake (motor), signal level dependent on switching status, high-side/low-side switch
	2	BR+	24 V brake	
	3	PE	PE	Cable shield for the holding brake and the temperature sensor (with Festo cables: n.c.)
	4	-MTdig	GND	Motor temperature sensor, N/C contact, N/O contact, PTC, KTY ...
	5	+Mtdig	+3.3 V 5 mA	
	6	PE	PE	Protective earth conductor from the motor
	7	W	Technical data → Tab. A.9	Connection of the three motor phases
	8	V		
	9	U		

1) Representation of the plug on the device of the motor controller CMMP-AS-...-3A-M3

Tab. 4.14 Pin assignment [X6] connection: Motor



The shielding for the motor cable must also be attached to the housing of the motor controller (spring clip: Fig. 2.5 → Page 18).

A motor holding brake can be connected to terminals BR+ and BR-. The locking brake is supplied from the logic supply of the motor controller. The maximum output current provided by the CMMP-AS-...-M3 motor controller must be observed.



To release the holding brake, care must be taken to maintain the voltage tolerances at the holding brake connection terminals. Also observe the specifications in Tab. A.4 → Page 66.

It may be necessary to insert a relay between the device and the holding brake, as shown in Fig. 4.5 → Page 40:

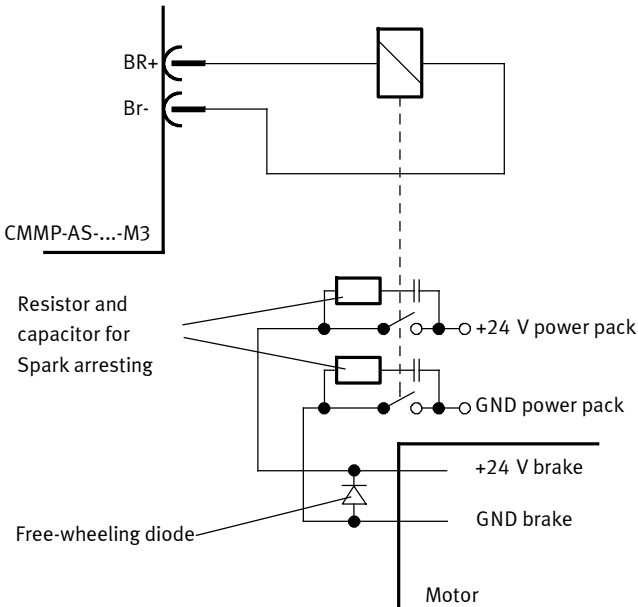

Fig. 4.5 Connecting a high-current holding brake to the device



Switching inductive DC currents via relays causes strong currents and sparks. For interference suppression, we recommend integrated RC interference suppressors, e.g. from Evox RIFA, designation: PMR205AC6470M022 (RC element with 22 Ω in series with 0.47 μF).

4.8 Connection: Voltage supply [X9]

The motor controller CMMP-AS-...-M3 receives its 24 VDC power supply for the control electronics via the plug connector [X9].

The main power supply for the motor controllers CMMP-AS-...-3A-M3 is 1-phase and for the motor controllers CMMP-AS-...-11A-P3-M3 3-phase.

4.8.1 Plug

CMMP-AS-...	Design on the device / coding		Counterplug / coding	
...-C2-3A-M3	PHOENIX Contact	Pin 9 (GND24V)	PHOENIX Contact	Pin 1 (L)
...-C5-3A-M3	MSTBA 2.5/9-G-5.08-BK		MSTB 2.5/9-ST-5.08-BK	
...-C5-11A-P3-M3	PHOENIX Power-COMBICON	–	PHOENIX Power-COMBICON	–
...-C10-11A-P3-M3	PC 5/11-G-7.62-BK		PC 5/11-ST-7.62-BK	

Tab. 4.15 Plug design [X9]

4.8.2 Pin allocation [X9] – 1-phase

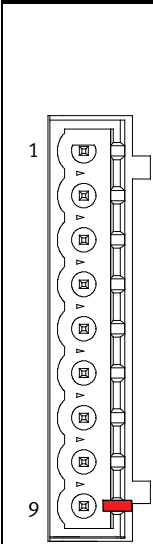
[X9] ¹⁾	Pin no.	Designation	Value	Specification
	1	L	100 ... 230 VAC	Mains phase
	2	N	±10% 50 ... 60 Hz	Mains neutral conductor (reference potential)
	3	ZK+	< 440 VDC	Alternative supply: Positive intermediate circuit voltage
	4	ZK-	GND_ZK	Alternative supply: Negative intermediate circuit voltage
	5	BR-INT	< 460 VDC	Internal braking resistor connection (bridge after BR-CH when using the internal resistor).
	6	BR-CH	< 460 VDC	Brake chopper connection for – internal braking resistor toward BR-INT – or – – external braking resistor against ZK+
	7	PE	PE	Connection for protective conductor from the mains
	8	+24 V	+24 VDC	Supply for control section, holding brake and I/O
	9	GND24 V	GND24 VDC	0 V supply reference potential

1) Representation of the contact strip on the motor controller CMMP-AS-...-3A-M3

Tab. 4.16 Pin allocation [X9] – 1-phase

4.8.3 Pin allocation [X9] – 3-phase

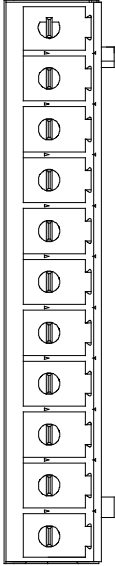
[X9] ¹⁾	Pin no.	Designation	Value	Specification
	1	L1	230 ... 480 VAC	Mains phase 1
	2	L2	±10%	Mains phase 2
	3	L3	50 ... 60 Hz	Mains phase 3
	4	ZK+	< 700 VDC	Alternative supply: Positive intermediate circuit voltage
	5	ZK-	GND_ZK	Alternative supply: Negative intermediate circuit voltage
	6	BR-EXT	< 800 VDC	Connection of the external braking resistor
	7	BR-CH	< 800 VDC	Brake chopper connection for – internal braking resistor against BR-INT – or – – external braking resistor against BR-EXT
	8	BR-INT	< 800 VDC	Internal braking resistor connection (bridge after BR-CH with use of the internal resistor)
	9	PE	PE	Connection for protective conductor from the mains
	10	+24 V	+24 VDC	Supply for control section, holding brake and I/O
	11	GND24 V	GND24 VDC	Supply reference potential

1) Representation of the contact strip on the motor controller CMMF-AS-...-11A-P3-M3

Tab. 4.17 Pin allocation [X9] – 3-phase

4.8.4 Mains fuse

In the mains power supply cable, an automatic circuit breaker ¹⁾ is installed for protection of the line:

Motor controller	Phases	Mains fuse
CMMP-AS-C2-3A-M3	1	B10
CMMP-AS-C5-3A-M3	1	B16
CMMP-AS-C5-11A-P3-M3	3	B16
CMMP-AS-C10-11A-P3-M3	3	B16

1) The required fuse is dependent, among other things, on the cable cross section, ambient temperature and laying procedure. Observe the following instructions!

Tab. 4.18 Required mains fuses



In designing the fuses, also observe the following standards:

- EN 60204-1 “Safety of machinery – Electrical equipment of machines – Part 1: General requirements”
- Take into consideration the legal regulations applicable for the destination as well as:
 - Regulations and standards,
 - Regulations of the testing organisations and insurers,
 - national specifications.

4.8.5 AC supply

Switch-on behaviour:

- As soon as the motor controller CMMP-AS-...-M3 is provided with mains voltage, the intermediate circuit is charged (< 1 s) via the braking resistors, with the intermediate circuit relay deactivated.
- After the intermediate circuit has been pre-charged, the relay engages and the intermediate circuit without resistors is connected directly to the mains supply.

AC supply with active PFC

The PFC step is available only for 1-phase motor controllers (CMMP-AS-...-3A-M3).



Note

Operation with mains line choke is not permissible, since the control circuit could be stimulated to oscillate.



Note

Operation with isolating transformer is not permissible since no reference potential (N) is available.



Note

When the load voltage is switched on, ensure that the reference potential (N) is switched before the phase (L1). This can be achieved through:

- unswitched reference potential (N)
- use of fuses with leading N when switching of the reference potential is not specified.

DC supply - intermediate circuit coupling

A direct DC power supply can be used for the intermediate circuit as an alternative to AC power or for achieving intermediate circuit coupling.

The intermediate circuits of several identically constructed motor controllers (CMMP-AS-...-3A-M0/-M3 or CMMP-AS-...-11A-P3-M0/-M3) can be connected via the terminals ZK+ and ZK- at plug connector [X9]. Coupling of the intermediate circuits is useful in applications where high braking energies occur or where motion must still be performed when the power supply fails.



Note

For 1-phase motor controllers (CMMP-AS-...-3A-M3), the PFC step must be deactivated when the motor controller is coupled through the intermediate circuit.



Note

If the intermediate circuits are coupled, it is imperative that all of the motor controllers are supplied via the same phase (e.g. L1) → Example Fig. 4.6.

Otherwise, the motor controllers will be damaged due to the resulting voltage at the rectifiers.

The maximum number of coupled motor controllers is limited by the power of the supply. Pay attention to a symmetrical load of the network here.

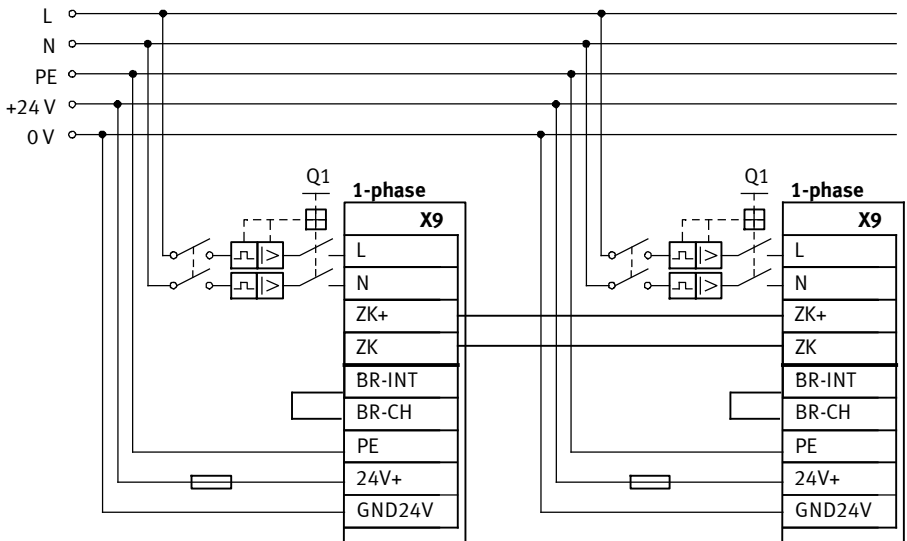

Fig. 4.6 Example of intermediate circuit coupling with common supply, single-phase



Fig. 4.6 is a schematic representation; note the information for mains fuses in → Section 4.8.4.

4.8.6 Braking resistor



If no external braking resistor is used, a bridge to the internal braking resistor must be connected in order for the intermediate circuit quick discharge to function! → Tab. 4.16 or Tab. 4.17.



For larger braking power an external braking resistor must be connected [X9] → Section 4.7.2 and Fig. 4.5.

4.9 Connection: Incremental encoder input [X10]

4.9.1 Plug [X10]

Motor controller	Design on the device	Counterplug
CMMP-AS-...-M3	Sub-D plug connector, 9-pin, socket	Sub-D plug connector, 9-pin, pins

Tab. 4.19 Plug design [X10]

4.9.2 Pin assignment [X10]

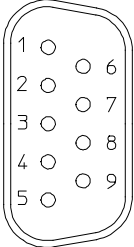
[X10]	Pin no.	Designation	Value	Specification
	1	A/CLK/CW	5 V $R_I \approx 120 \Omega$	Incremental encoder signal A Stepper motor signal CLK Pulses clockwise CW pos. polarity in accordance with RS422
	6	A#/CLK#/CW#	5 V $R_I \approx 120 \Omega$	Incremental encoder signal A Stepper motor signal CLK Pulses clockwise CW neg. polarity in accordance with RS422
	2	B/DIR/CCW	5 V $R_I \approx 120 \Omega$	Incremental encoder signal B Stepper motor signal DIR Pulses counterclockwise CCW pos. polarity in accordance with RS422
	7	B#/DIR#/CCW#	5 V $R_I \approx 120 \Omega$	Incremental encoder signal B Stepper motor signal DIR Pulses counterclockwise CCW neg. polarity in accordance with RS422
	3	N	5 V $R_I \approx 120 \Omega$	Incremental encoder zero pulse N pos. polarity in accordance with RS422
	8	N#	5 V $R_I \approx 120 \Omega$	Incremental encoder zero pulse N neg. polarity in accordance with RS422
	4	GND	–	Reference GND for encoder
	9	GND	–	Screening for the connecting cable
	5	VCC	+5 V $\pm 5\%$ 100 mA	Auxiliary supply, maximum load 100 mA, short-circuit proof!

Tab. 4.20 Pin allocation X10: Incremental encoder input



When connecting two motor controllers in the master-slave mode via [X11] and [X10], the pins 5 (+5 V - auxiliary supply) must not be connected to each other.

4.9.3 Type and design of the cable [X10]

We recommend use of the encoder connection lines in which the incremental encoder signal is twisted by pairs and the individual pairs are screened.

4.9.4 Connection instructions [X10]

Input [X10] can be used for processing incremental encoder signals and also for pulse direction signals as generated by stepper motor controller cards.

The input amplifier at the signal input is designed for processing differential signals as per the RS422 interface standard.

4.10 Connection: Incremental encoder output [X11]

4.10.1 Plug [X11]

Motor controller	Design on the device	Counterplug
CMMP-AS-...-M3	Sub-D plug connector, 9-pin, socket	Sub-D plug connector, 9-pin, pins

Tab. 4.21 Plug design [X11]

4.10.2 Pin assignment [X11]

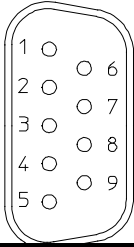
[X11]	Pin no.	Designation	Value	Specification
	1	A	5 V RA $\approx 66 \Omega^1$	Incremental encoder signal A
	6	A#	5 V RA $\approx 66 \Omega^1$	Incremental encoder signal A#
	2	B	5 V RA $\approx 66 \Omega^1$	Incremental encoder signal B
	7	B#	5 V RA $\approx 66 \Omega^1$	Incremental encoder signal B#
	3	N	5 V RA $\approx 66 \Omega^1$	Incremental encoder zero pulse N
	8	N#	5 V RA $\approx 66 \Omega^1$	Incremental encoder zero pulse N#
	4	GND	-	Reference GND for encoder
	9	GND	-	Screening for connecting cable
	5	VCC	+5 V $\pm 5\%$ 100 mA	Auxiliary supply, maximum load 100 mA, short-circuit proof!

1) The specification for RA designates the differential output resistance

Tab. 4.22 Pin assignment [X11]: Incremental encoder output

The output driver at the signal output provides differential signals (5 V) as per the RS422 interface standard. Up to 32 other controllers can be addressed by one device.



When connecting two motor controllers in the master-slave mode via [X11] and [X10], the pins 5 (+5 V - auxiliary supply) must not be connected to each other.

4.11 FCT interfaces

4.11.1 Overview of interfaces

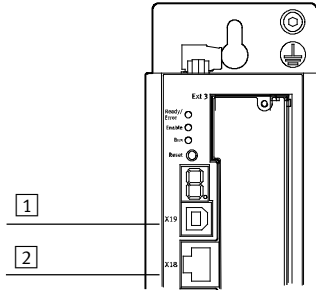

1 [X19]: USB

2 [X18]: Ethernet

Fig. 4.7 FCT interfaces

4.11.2 USB [X19]

The equipment of the series CMMP-AS-...-M3 have a USB interface for parametrisation. The USB interface is used as a configuration interface for the FCT configuration.

The following functions are supported:

- Simulation of the RS232 interface via USB
- Complete parametrisation of the CMMP-AS-...-M3 via FCT
- Firmware download via FCT

Interface design

The plug connector is designed as a Type B terminal socket. All standard terminal cables up to a length of 5m can be used. If longer cables are required, the corresponding USB repeaters must be used.

The USB interface is designed as a pure slave interface (the CMMP-AS...-M3 is the slave, the PC is the host). It meets the USB specification Rev. USB 1.1.

USB driver for the PC

The FCT connection is made via the standard Kernel Mode driver “WinUsb.sys” and the device configuration and the access to the endpoints via the WinUSB API.

The USB driver package is a component of the FCT installation.

The following operating systems are supported through this:

- Windows XP from Service Pack 2
- Windows Vista
- Windows 7

The WinUsb.sys is installed as equipment function driver.

4.11.3 Ethernet TCP/IP [X18]

The equipment of the series CMMP-AS-...-M3A have a USB interface for parametrisation.

The following functions are supported:

- Point-to-point communication between PC and motor controller for parametrisation
- Complete parametrisation of the CMMP-AS-...-M3 via FCT
- Communication from one PC or one PLC to several CMMP-AS-...-M3 that are located in the same local network for the purpose of monitoring, adaptation of the parametrisation or also process control of the controller.



Note

Unauthorised access to the device can cause damage or malfunctions.

When connecting the device to a network:

- Protect the network from unauthorised access.

Measures for protecting the network include:

- Firewall
- Intrusion Prevention System (IPS)
- Network segmentation
- Virtual LAN (VLAN)
- Virtual private network (VPN)
- Security at physical access level (Port Security).

For further information → Guidelines and standards for security in information technology, e.g. IEC 62443, ISO/IEC 27001.

Interface design

The interface in the device is designed as an 8P8C socket (RJ45).

The connection has two LEDs with the following function:

- Yellow Physical Link Detect (network connection available)
- Green Data Connection (data connection / data exchange)

The interface is designed to conform to the IEEE 802.3u specification. Cables of type FTP5 or high-order must be used with 100Base-TX. The interface supports the autosensing function for automatic identification of the connected cable. Both standard patch cables (1:1) and Crosslink (crossed) cables can be used.

Supported services

The following services are supported by the Ethernet interface:

- TCP/IP
- UDP/IP
- DNS (ARP and BOOTP)
- DHCP
- AutoIP
- TFTP



TFTP must be activated separately in Windows if necessary and a pass rule defined in the Firewall.

Address allocation

The network settings (IP address, subnetwork mask, gateway) can either be automatically obtained or manually specified:

- Automatically via DHCP (the automatically obtained IP address lies in the IP range specified by the DHCP server)
- Automatically via Auto IP (if no DHCP server was found, an address between 169.254.1.0 and 169.254.254.255 is selected pseudorandomly)
- Manual IP assignment (manual setting of the network parameters via FCT)

The following sequence applies for connection set-up:

1. DHCP
2. AutoIP
3. Static IP address

If no IP address can be obtained via the higher-level service, the following service is used. Thus if no address can be obtained via DHCP, first an AutoIP and then a static address is used.

4.12 Instructions on safe and EMC-compliant installation

4.12.1 Explanations and terms

Electromagnetic compatibility (EMC) or electromagnetic interference (EMI) involves the following requirements:

Resistance to interference

Sufficient interference immunity of an electrical system or electrical device against external electrical, magnetic or electromagnetic noise via lines or space.

Emitted interference

Sufficiently low emitted interference of electrical, magnetic or electromagnetic interference of an electrical system or an electrical device on other devices in the environment via cables and space.



Warning

All PE protective earth conductors must always be connected prior to commissioning for reasons of safety.

The mains-side PE connection is made to the PE connection points (device rear wall) and [X9] of the CMMP-AS-...-M3.

Make sure that the earth connections between devices and the mounting plate are of sufficiently large dimensions in order to be able to discharge HF interference.

4.12.2 General remarks on EMC

Interference emission and resistance to interference of a motor controller always depend on the complete design of the drive, which consists of the following components:

- Voltage supply
- Motor controller
- Motor
- Electromechanical components
- Design and type of wiring
- Connection to the higher-order controller

In order to increase the resistance to interference and decrease the emitted interference, the CMMP-AS-...-M3 motor controller already has integrated motor chokes and mains filters, which means that the CMMP-AS-...-M3 motor controller can be operated without additional shielding and filters in most applications.



The motor controllers CMMP-AS-...-M3 been checked in accordance with EMC product standard EN 61800-3 that is applicable to electric drives. The standard components from the Festo accessories were used for qualification. EMC can only be guaranteed if the motor and encoder or resolver cables from Festo are used and not extended or changed in any other form.

In the majority of cases, no external filter measures are required (→ Section 4.12.3, Tab. 4.23).

The declaration of conformity is available at → www.festo.com.

4.12.3 EMC areas: First and second environment

If installed correctly and if all connecting cables are wired correctly, the CMMP-AS-...-M3 motor controllers fulfil the specifications of the related product standard EN 61800-3. This standard no longer refers to limit value classes, but to so-called environments.



Note

The first environment (C2) includes electricity grids connected to residential housing; the second environment (C3) includes grids connected only to industrial plants.



The device may generate high frequency interference in residential areas, which may make it necessary to implement interference suppression measures.

Applicable for the motor controller CMMP-AS-...-M3:

EMC class	Area	Compliance with EMC requirements
Emitted interference	Second environment (industrial)	Motor cable lengths up to 25 m without external filters. A suitable mains filter must be installed when longer motor cables of 25 ... 50 m are used.
Resistance to interference	Second environment (industrial)	Independent of the motor cable length.

Tab. 4.23 EMC requirements

4.12.4 EMC-compliant wiring

The following must be observed for EMC-compliant design of the drive system (see also chapter 4.2 → Page 27):

Cable interfaces on the CMMP-AS-...-M3			
Port	Interface	Cable length [m]	Comment
X1	I/O communication	≤ 5	Recommendation: Screened
X2A	Resolver	≤ 50	screened
X2B	Encoder	≤ 50	screened
X4	CAN	≤ 40	at 1 Mbit/s (line length dependent on the bit rate)
X6	Motor	≤ 25	screened (< 50 m with external filter measures)
X9	Power supply	≤ 2	–
X10	Incremental encoder input	≤ 30	screened
X11	Incremental encoder output	≤ 5	screened
X18	Ethernet	≤ 10	at least CAT-5
X19	USB	≤ 5	in accordance with USB specification Rev. USB 1.1

Tab. 4.24 Permissible cable lengths on the CMMP-AS-...-M3

1. To keep leaked current and losses in the motor cable as low as possible, the motor controller CMMP-AS-...-M3 should be placed as close to the motor as possible (→ Chapter 4.12.5 → Page 54).
2. Motor and encoder cable must be screened.
3. The screening of the motor cable is attached to the housing of the motor controller CMMP-AS-...-M3 (screened connection terminals, spring clips). The cable screening is also always attached to the corresponding motor controller to prevent leaked current flowing back to the controller which caused it.
4. The mains-side PE connection is connected to the PE connection point of the power supply [X9] and to the PE connection of the housing.
5. The PE internal conductor of the motor cable is connected to the PE connection point of the motor connection [X6].
6. Signal lines must be separated as far as possible from the power cables. They should not be routed parallel to one another. If crossovers are unavoidable, they should be made as close to vertical (i.e. at a 90° angle) as possible.
7. For unscreened signal and control lines, safe/reliable operation cannot be guaranteed. If they must be used, they should at least be twisted.
8. Even screened cables always have short unscreened parts at both ends (unless a screened plug housing is used).

In general:

- Connect the inner screenings to the pins of the plug connectors provided for the purpose; length maximum 40 mm.
- Length of the unscreened wires with self-made cables, maximum 35 mm.
- Connect entire screening on the controller side flush to the PE terminal; maximum length 40 mm.
- Connect entire screening flush at the motor to the plug or motor housing; length maximum 40 mm (guaranteed with NEBM-...).



Danger

All PE protective earth conductors must always be connected prior to commissioning for reasons of safety.

The regulations of EN 50178 and EN 60204-1 for protective grounding must always be observed during installation!

4.12.5 Operation with long motor cables

For applications in combination with long motor cables and/or if the wrong motor cables are selected with excessive cable capacity, the filters may be subjected to thermal overload. To avoid this, it is necessary to enter the cable length used in the application in the FCT parametrisation software. By using this information the FCT plug-in then automatically calculates the optimal cycle time for the current regulator and PWM control. The following restrictions are taken into consideration:

Cable length	Restrictions in the FCT plug-in CMMP
≤ 15 m	<ul style="list-style-type: none"> – The minimum value for “cycle time current regulator” is 62.5 μs.¹⁾ – The option “half output stage frequency” is set and can be edited.²⁾
> 15 m, ≤ 25 m	<ul style="list-style-type: none"> – The minimum value for “cycle time current regulator” is 62.5 μs.¹⁾ – The option “half output stage frequency” is set and cannot be edited.
> 25 m	<ul style="list-style-type: none"> – The minimum value for “cycle time current regulator” is 125 μs and cannot be edited. – The option “half output stage frequency” is set and cannot be edited.

1) The actual value is automatically determined by the FCT based on the motor controller axis combination.

2) The ability to edit the option “half output stage frequency” does not apply to three-phase controllers.

Tab. 4.25 Restrictions in the FCT plug-in depending on the cable length

In addition, the following procedure is strongly recommended for applications in which long motor cables are required:

- From a cable length of > 25 m, use only cables with a capacitance between the motor phase and screening of < 200 pF/m, or better, < 150 pF/m and also use a mains filter!



Note

Longer cable lengths result in deviations to the current regulator amplification (line resistance).

4.12.6 ESD protection



Caution

Unused Sub-D plug connectors present a danger of damage to the device or to other parts of the system as a result of ESD (electrostatic discharge).

In the design of the motor controller CMMP-AS-...-M3, great importance has been placed on high resistance to interference. For this reason, individual function blocks are galvanically separated from each other. Signal transmission within the device is performed via an optocoupler.

A distinction is made between the following separated areas:

- Output stage with intermediate circuit and mains input
- Control electronics with analogue signal processing
- 24 V supply and digital inputs and outputs

5 Commissioning

5.1 General connection instructions



As the installation of the connecting cables is critical for EMC, the preceding chapter 4.12.4 → Page 52 must be observed!



Warning

Non-compliance with the safety instructions in chapter 1 → Page 9 can result in material damage, injury, electric shock, or in extreme cases, fatality.

5.2 Tool / material

- Slotted head screwdriver size 1
- USB or EtherNet cable for parameterisation
- Encoder cable
- Motor cable
- Power supply cable
- Control line

5.3 Connecting the motor

1. Connect motor cable on the motor side.
2. Insert the PHOENIX plug into the socket [X6] on the device.
3. Clamp the cable shields to the shield terminals (not suitable as strain-relief).
4. Connect encoder cable on the motor side.
5. Insert the Sub-D plug connector into socket [X2A] resolver or [X2B] encoder of the device and tighten the locking screws.
6. Check all plug connectors once again.

5.4 Connect motor controller CMMP-AS-...-M3 to the power supply



Warning

Danger of electric shock.

- When modules or cover plates are not mounted on the slots Ext1 ... Ext3.
- When cables are not mounted to the plugs [X6] and [X9].
- When connecting cables are disconnected when powered.

Touching live parts causes severe injuries and can lead to death.

The product may only be operated in a built-in status and when all safeguards have been initiated.

Before touching live parts during maintenance, repair and cleaning work and when there have been long service interruptions:

1. Switch off power to the electrical equipment via the mains switch and secure it against being switched on again.
2. After switch-off, wait at least 5 minutes discharge time and check that power is turned off before accessing the controller.

1. Make sure that the power supply is switched off.
2. Connect the PE cable of the mains supply to the PE earth socket.
3. Insert the PHOENIX plug into the socket [X9] of the motor controller.
4. Connect 24 V connections with appropriate power pack.
5. Make the network power supply connections.
6. Check all plug connectors once again.

5.5 Connect the PC

1. Connect PC via USB → 4.11.2 USB [X19] or Ethernet → 4.11.3 Ethernet TCP/IP [X18] to the motor controller.

5.6 Check operating status

1. Make sure that the controller enable is switched off (controller enable: DIN 5 at [X1]).
2. Switch on the power supplies of all equipment.

During the boot procedure, the point of the 7-segment display lights up.

After completion of the boot process, the READY-LED lights up green.



If the READY LED lights up red, there is a malfunction. If an “E” appears in the 7-segment display followed by a sequence of numbers, this is an error message and you must rectify the cause of the error. In this case, continue to read in the chapter A → Page 64.

If no indicator lights up on the device, execute the following steps:

1. Switch off the power supply.
2. Wait 5 minutes to allow the intermediate circuit to discharge.
3. Check all connecting cables.
4. Check that the 24 V power supply is functional.
5. Switch on the power supply again.
6. If still no indicator lights up, → Device is defective.

6 Service functions and diagnostic messages

6.1 Protective and service functions

6.1.1 Overview

The motor controller CMMP-AS-...-M3 has a complex array of sensors that monitor the controller section, power output stage, motor and external communication to ensure that they function excellently. All diagnostic events which occur are saved in the internal diagnostic memory. Most errors cause the controller section to switch off the motor controller and the power output stage. The motor controller cannot be switched back on until the error is remedied and then acknowledged.

A complex system of sensors and numerous monitoring functions ensure operational reliability:

- Measurement of the motor temperature
- Measurement of the power output stage temperature
- Earth fault detection (PE)
- Detection of short-circuits between two motor phases
- Detection of overvoltages in the intermediate circuit
- Detection of faults in the internal voltage supply
- Collapse of supply voltage
- Detection of faults in conjunction with the functional safety engineering (slot Ext3)

6.1.2 Phases and mains failure detection

The motor controllers CMMP-AS-...-11A-P3-M3 detect a phase failure in three-phase operation (phase failure detection) or failure of several phases (network failure detection) of the mains supply at the device.

6.1.3 Overload current and short-circuit monitoring

Overload current and short-circuit monitoring detects short circuits between two motor phases and short circuits at the motor output terminals against the positive and negative reference potential of the intermediate circuit and against PE. If the error control detects overload current, the power output stage shuts down immediately, guaranteeing protection against short circuits.

6.1.4 Overvoltage monitoring for the intermediate circuit

The overvoltage monitoring for the intermediate circuit takes effect as soon as the intermediate circuit voltage exceeds the operating voltage range. The power output stage is then deactivated.

6.1.5 Temperature monitoring for the heat sink

The heat sink temperature of the output end stage is measured with a linear temperature sensor. The temperature limit varies from device to device → Tab. A.3 on page 65. A temperature warning is triggered at about 5°C below the limit value.

6.1.6 Monitoring of the motor

The motor controller CMMP-AS-...-M3 has the following protective functions for monitoring the motor and the connected shaft encoder:

Protective function	Description
Monitoring the shaft encoder	An error of the shaft encoder results in switching off of the power output stage. For the resolver, for example, the tracking signal is monitored. For incremental encoders, the commutation signals are checked. Generally true for intelligent encoders is that their various error messages are evaluated and reported to the CMMP-AS-...-M3 as common error E 08-8.
Measurement and monitoring of the motor temperature	The motor controller CMMP-AS-...-M3 has a digital and an analogue input for recording and monitoring the motor temperature. They are selectable as temperature sensors. <ul style="list-style-type: none"> – [X6]: Digital input for PTCs, N/C contacts and N/O contacts. – [X2A] and [X2B]: N/C contact and KTY series analogue sensors. Other sensors (NTC, PTC) require a corresponding software adaptation as needed.

Tab. 6.1 Protective functions of the motor

6.1.7 I²t monitoring

The motor controller CMMP-AS-...-M3 has I²t monitoring to limit the average power loss in the power end stage and in the motor. Since the power loss that occurs in the power electronics and the motor can, in the worst case, grow at a rate equal to the square of the flowing current, the squared current value is taken as a measure for the power loss.

6.1.8 Power monitoring for the brake chopper

The braking resistors are monitored on the firmware side through the function I²t brake chopper. When the power monitoring “I²t brake chopper” of 100% is reached, the output of the internal braking resistor is limited to the rated output.



Note

As a result of this switch-back, the error “E 07-0” “Overvoltage in the intermediate circuit” is generated. If the braking process is not completed, the residual energy is fed back to the motor controller and results in an uncontrolled running out of the drive if no automatic locking mechanical system, clamping units or weight compensation is used.

This can result in damage to the machine. Connection of an appropriate clamping unit to prevent an uncontrolled running out of the drive at the motor controller is recommended.

In addition, the brake chopper is protected by means of overcurrent detection. If a short circuit is detected via the braking resistor, the brake chopper controller is switched off.

6.1.9 Commissioning status

Motor controllers sent to Festo for servicing are loaded with other firmware and parameters for testing purposes.

Before it is commissioned again at the location of the final customer, the motor controller CMMP-AS-...-M3 must be parametrised. The parametrisation software queries the commissioning status and prompts the user to parameterise the motor controller. In parallel, the device signals through the visual indicator 'A' on the 7-segment display that, although it is ready for operation, it has not been parametrised yet.

6.1.10 Rapid discharge of the intermediate circuit

When a mains supply failure is detected, the intermediate circuit is quickly discharged within the safety time specified in EN 60204-1.

Delayed connection of the brake chopper by power class in parallel operation and when a mains failure occurs ensures that the main energy during rapid discharge of the intermediate circuit is taken over through the braking resistors of the higher power classes.



But the rapid discharge can be ineffective in certain device constellations, especially when several motor controllers are connected in parallel in the intermediate circuit or a brake resistance is not connected. The motor controllers may carry dangerous voltage for up to 5 minutes after being switched off (capacitor residual charge).

6.1.11 Detection of faults in conjunction with the functional safety engineering

- Detection of module replacement (51-1 to 51-6)
- Discrepancy time monitoring STO (CAMC-G-S1)
- Driver supply monitoring
- Plausibility check of the control signals for brake control (51-5)
- Representation of error messages of the CAMC-G-S3 (53-x to 59-x)

6.2 Operating mode and diagnostic messages

6.2.1 Operation and display components











The motor controller CMMP-AS-...-M3 has three LEDs on the front and one 7-segment display for showing the operating statuses.

Element	LED colour	Function
7-segment display	–	Displays the operating mode and a coded error number should an error occur → Section 6.2.2
LED1	Green	Operating status
	Red	Error
LED2	Green	Controller enable
LED3	Yellow	CAN bus status display
RESET button	–	Hardware reset for the processor

Tab. 6.2 Display components and RESET pushbutton

6.2.2 7-segment display

The display and the meaning of the symbols shown are illustrated in the following table:

Display ¹⁾	Meaning
	A The motor controller must still be parameterised.
	F Signals that firmware is currently being loaded into the flash.
	. (flashes) Bootloader active (only the point flashes).
	d Signals that a parameter set is currently being loaded from the SD card to the controller.
	H (flashes) “H”: The motor controller is in the “safe status”. This does not have the same meaning as the information on the status of the safety function STO (Safe Torque Off).
	H E L L O Display for the function “Identify Controller”.
	(rotating) The outer segments are displayed “rotating” in the speed adjustment operating mode. The display depends on the actual position or speed. The middle bar is only active when controller enable is active.
	I Controlled torque operation.
	P x x x Positioning (“xxx” stands for the record number, see below).
	000 No positioning active.
	001...255 Positioning record 001 ... 255 active.
	259/260 Jog positive/negative.
	262 CAM-IN / CAM-OUT (cam disc).
	264/265 Direct records for manual travel via FCT or FHPP direct operation.
	P H x Homing (“x” stands for the homing phase, see below).
	0 Phase “Search for reference point”.
1 Phase “Crawl”.	
2 Phase “Approach zero point”.	
	E x x y Error message with main index “xx” and sub-index “y”.
	- x x y Warning message with main index “xx” and sub-index “y”. A warning is shown at least twice on the 7-segments display.

1) Several characters are displayed one after the other.

Tab. 6.3 Operating mode and error display

6.2.3 Acknowledgement of error messages

Error messages can be acknowledged through:

- the parametrisation interface
- the fieldbus (control word)
- a decreasing edge at DIN5 [X1]

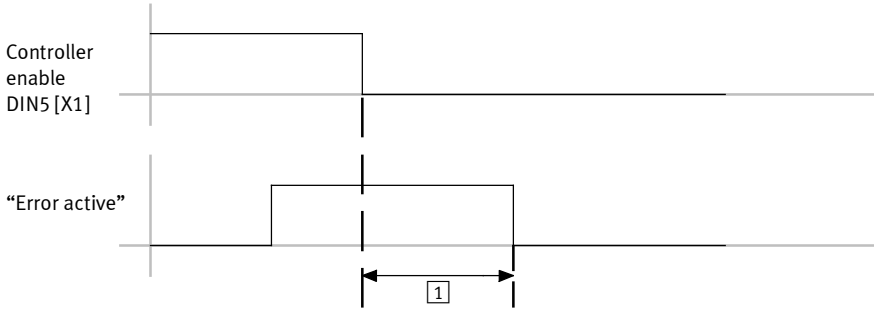

1 ≈ 80 ms

Fig. 6.1 Timing diagram: Acknowledge error



Diagnostic events which are parametrised as warnings are automatically acknowledged when the cause is no longer on hand.

6.2.4 Diagnostic messages

The significance and their measures for diagnostic messages are summarised in the following chapter:

→ Chapter A Technical appendix

7 Maintenance, care, repair and replacement

7.1 Maintenance and care



Warning

Danger of electric shock.

Touching live parts causes severe injuries and can lead to death. Do not disconnect connecting cables when powered.

Before touching live parts during maintenance, repair and cleaning work and when there have been long service interruptions:

1. Switch off power to the electrical equipment via the mains switch and secure it against being switched on again.
2. After switch-off, wait at least 5 minutes discharge time and check that power is turned off before accessing the controller.

If used as intended, the product is maintenance-free.

- Clean the outside of the product with a soft cloth.

7.2 Repair



Repair or maintenance of the product is not permissible. If necessary, replace the complete product.

7.3 Replacement and disposal

7.3.1 Dismounting and installation



When dismantling, please observe the safety instructions in section 7.1

Information regarding installation can be found here:

- Mounting → Section 3.2.
- Electrical installation → Chapter 4.
- Commissioning → Chapter 5.

7.3.2 Disposal



Observe the local regulations for environmentally appropriate disposal of electronic modules. The product is RoHS-compliant.

A Technical appendix

A.1 Technical data CMMP-AS-...-M3

General technical data				
CMMP-AS-	C2-3A-M3	C5-3A-M3	C5-11A-P3-M3	C10-11A-P3-M3
Type of mounting	Screwed onto connecting plate			
Display	7-segment display			
Parameterisation interface	USB 1.1			
	EtherCat TCP/IP			
Approvals				
CE marking (see declaration of conformity)	In accordance with EU Low Voltage Directive			
	In accordance with EU EMC Directive			
	In accordance with EU Machinery Directive			
Dimensions and weight				
Dimensions (HxWxD) ¹⁾ [mm]	202x66x207	227x66x207	252x79x247	
Mounting plate dimensions [mm]	248x61		297x75	
Weight [kg]	2.1	2.2	3.5	

1) without plugs, shield screw and screw heads

Tab. A.1 Technical data, general

Transport and storage				
CMMP-AS-	C2-3A-M3	C5-3A-M3	C5-11A-P3-M3	C10-11A-P3-M3
Temperature range [°C]	-25 ... +70			

Tab. A.2 Technical data: Transport and storage

Operating and environmental conditions				
CMMP-AS-	C2-3A-M3	C5-3A-M3	C5-11A-P3-M3	C10-11A-P3-M3
Permissible setup altitude above sea level				
with rated output	[m]	1000		
with power reduction	[m]	1000 ... 2000		
Air humidity	[%]	0 ... 90 (non-condensing)		
Protection class		IP20		
Degree of contamination		2		
Without safety module CAMC-G-S3 in slot Ext 3				
Operating temperature	[°C]	0 ... +40		
Operating temperature with power reduction of 2.5 % per Kelvin	[°C]	+40 ... +50		
With safety module CAMC-G-S3 in slot Ext 3				
Ambient temperature ¹⁾	[°C]	0 ... +35	0 ... +40	0 ... +40
Ambient temperature with power reduction ¹⁾	[°C]	+35 ... +40	+40 ... +50	+40 ... +50
		An overtemperature switch-off will take place at a high power output of the basic unit and/or high load of the control section and the I/Os.		
Switch-off temperature, heat sink power section	°C	100	80	80

- 1) The maximum permissible operating temperature is dependent on numerous parameters, including the number of switched inputs and the load of the outputs in the CAMC-G-S3, the equipment of additional modules in EXT1 and EXT2 in the CMMP-AS-M3, the load of the power output stage in the CMMP-AS-M3 as well as the airflow conditions in the control cabinet. The specified values apply to a typical device configuration. The CAMC-G-S3 possesses separate temperature monitoring, which switches the safety module and the basic unit off, if the electronics temperature becomes too high.

Tab. A.3 Technical data: Operating and environmental conditions

Electrical data logic supply				
CMMP-AS-	C2-3A-M3	C5-3A-M3	C5-11A-P3-M3	C10-11A-P3-M3
Nominal voltage [V DC]	24 ±20%			
Nominal current ¹⁾ [A]	0.55	0.65	1	
Maximum current [A] for holding brake	1		2	
With higher current requirement → Fig. 4.5 page 40				

1) plus current consumption from an existing holding brake and I/Os

Tab. A.4 Technical data: Logic supply



Note

With a warm motor and a supply voltage that is too low (outside of tolerance), the motor's brakes cannot open 100%, which can lead to premature wearing of the brake.

Electrical data load voltage				
CMMP-AS-	C2-3A-M3	C5-3A-M3	C5-11A-P3-M3	C10-11A-P3-M3
Number of phases	1		3	
Voltage range [V AC]	100 ... 230 ±10%		230 ... 480 ±10%	
Mains frequency [Hz]	50 ... 60			
Max. nominal current in continuous operation [A _{eff}]	2.4	4.7	5	9
Intermediate circuit voltage (without PFC) [V DC]	310 ... 320		560 ... 570	
Intermediate circuit voltage (with PFC) [V DC]	360 ... 380		–	
Alternative DC supply [V DC]	60 ... 380		60 ... 700	
Power data of the PFC step with nominal supply voltage of 230 VAC ±10%				
Continuous output [W]	500	1000	–	
Peak power [W]	1000	2000	–	

Tab. A.5 Technical data: Load voltage

Technical data braking resistor				
CMMP-AS-	C2-3A-M3	C5-3A-M3	C5-11A-P3-M3	C10-11A-P3-M3
Braking resistor, integrated				
Resistance value [Ω]	60		68	
Pulse power [kW]	2.8		8.5	
Continuous output [W]	10	20	110	
Trigger level (without PFC) [V]	389		760	
Trigger level (with PFC) [V]	440		–	
Max. voltage (without PFC) [V]	400		800	
Max. voltage (with PFC) [V]	460		–	
Braking resistor, external				
Resistance value [Ω]	≥ 50		≥ 40	
Operating voltage [V]	≥ 460		≥ 800	
Continuous output [W]	≤ 2500		≤ 5000	

Tab. A.6 Technical data: Braking resistor

Motor cable				
CMMP-AS-	C2-3A-M3	C5-3A-M3	C5-11A-P3-M3	C10-11A-P3-M3
Max. motor cable length for second environment [m]	≤ 25 (without filter)			
Cable capacity of one phase against screening [pF/m]	≤ 200			

Tab. A.7 Technical data: Motor cable

Motor temperature monitoring	
Digital sensor	N/C contact: $R_{Cold} < 500 \Omega$ $R_{Hot} > 100 k\Omega$
Analogue sensor	Silicon temperature sensor, e.g. KTY81, 82 or similar. R25 ≈ 2000 Ω R100 ≈ 3400 Ω

Tab. A.8 Technical data: Motor temperature monitoring

Output data				
CMMP-AS-	C2-3A-M3 ¹⁾	C5-3A-M3 ¹⁾	C5-11A-P3-M3 ²⁾	C10-11A-P3-M3 ²⁾
Voltage [VAC]	0 ... 270		0 ... 360	
Nominal power [kVA]	0.5	1	3	6
Max. Power for 5 seconds [kVA]	1	2	6	12

1) Data for operation with 1x230 VAC [± 10%], 50 ... 60 Hz

2) Data for operation with 3x400 VAC [±10%], 50 ... 60 Hz

Tab. A.9 Technical data: Output data



Note

The following tables Tab. A.10, Tab. A.11, Tab. A.12, Tab. A.13, Tab. A.14 and Tab. A.15 describe the maximum possible output data of the motor controller. The specified options “cycle time current regulator” and “half output stage frequency” are automatically calculated in the FCT plug-in based on the parameterised motor controller/motor-axis combination. This calculation determines the best values to prevent an overloading of the components.

In addition, the length of the motor cable is also incorporated into the calculation in order to protect the mains filters contained in the motor controller → Section 4.12.5.

CMMP-AS-C2-3A-M3				
Cycle time current regulator ¹⁾ [μs]	62.5		125	
Half output stage frequency ¹⁾	active	inactive	active	inactive
Output stage frequency [kHz]	8	16	4	8
Nominal output current [A _{eff}]	2.5	2.2	2.5	2.5
Maximum output current for maximum time				
Max. output current [A _{eff}]	5	4.4	5	5
Max. time [s]	5	5	5	5
Max. output current [A _{eff}]	7.5	6.6	7.5	7.5
Max. time [s]	1.3	1.3	1.3	1.3
Max. output current [A _{eff}]	10	8.8	10	10
Max. time [s]	0.5	0.5	0.5	0.5

1) Option with FCT able to be parameterised

Tab. A.10 Output data CMMP-AS-C2-3A-M3

CMMP-AS-C5-3A-M3					
Cycle time current regulator ¹⁾	[μ s]	62.5		125	
Half output stage frequency ¹⁾		active	inactive	active	inactive
Output stage frequency	[kHz]	8	16	4	8
Nominal output current	[A_{eff}]	5	4.4	5	5
Maximum output current for maximum time					
Max. output current	[A_{eff}]	10	8.8	10	10
Max. time	[s]	5	5	5	5
Max. output current	[A_{eff}]	15	13.2	15	15
Max. time	[s]	1.3	1.3	1.3	1.3
Max. output current	[A_{eff}]	20	17.6	20	20
Max. time	[s]	0.5	0.5	0.5	0.5

1) Option with FCT able to be parametrised

Tab. A.11 Output data CMMP-AS-C5-3A-M3

CMMP-AS-C5-11A-P3-M3					
Cycle time current regulator ¹⁾	[μ s]	62.5		125	
Half output stage frequency ¹⁾		active	inactive	active	inactive
Output stage frequency	[kHz]	8	16	4	8
Nominal output current	[A_{eff}]	5	2.5	5	5
Maximum output current for maximum time					
Max. output current	[A_{eff}]	10	5	10	10
Max. time	[s]	5	5	5	5
Max. output current	[A_{eff}]	15	7.5	15	15
Max. time	[s]	0.8	1.2	0.8	0.8
Max. output current	[A_{eff}]	20	10	20	20
Max. time	[s]	0.1	0.15	0.1	0.1

1) Option with FCT able to be parametrised

Tab. A.12 Output data CMMP-AS-C5-11A-P3-M3 with electrical rotation frequency ≤ 5 Hz

CMMP-AS-C5-11A-P3-M3					
Cycle time current regulator ¹⁾	[μ s]	62.5		125	
Half output stage frequency ¹⁾		active	inactive	active	inactive
Output stage frequency	[kHz]	8	16	4	8
Nominal output current	[A _{eff}]	5	2.5	5	5
Maximum output current for maximum time					
Max. output current	[A _{eff}]	10	5	10	10
Max. time	[s]	5	5	5	5
Max. output current	[A _{eff}]	15	7.5	15	15
Max. time	[s]	2	2	2	2
Max. output current	[A _{eff}]	20	10	20	20
Max. time	[s]	0.5	0.5	0.5	0.5

1) Option with FCT able to be parametrised

Tab. A.13 Output data CMMP-AS-C5-11A-P3-M3 with electrical rotation frequency ≥ 20 Hz

CMMP-AS-C10-11A-P3-M3					
Cycle time current regulator ¹⁾	[μ s]	62.5		125	
Half output stage frequency ¹⁾		active	inactive	active	inactive
Output stage frequency	[kHz]	8	16	4	8
Nominal output current	[A _{eff}]	8	3.45	10	8
Maximum output current for maximum time					
Max. output current	[A _{eff}]	16	6.9	20	16
Max. time	[s]	5	5	5	5
Max. output current	[A _{eff}]	24	10.35	30	24
Max. time	[s]	0.1	0.2	0.1	0.1
Max. output current	[A _{eff}]	32	13.8	40	32
Max. time	[s]	0.07	0.15	0.07	0.07

1) Option with FCT able to be parametrised

Tab. A.14 Output data CMMP-AS-C10-11A-P3-M3 with electrical rotation frequency ≤ 5 Hz

CMMP-AS-C10-11A-P3-M3					
Cycle time current regulator ¹⁾	[μ s]	62.5		125	
Half output stage frequency ¹⁾		active	inactive	active	inactive
Output stage frequency	[kHz]	8	16	4	8
Nominal output current	[A_{eff}]	8	3.45	10	8
Maximum output current for maximum time					
Max. output current	[A_{eff}]	16	6.9	20	16
Max. time	[s]	5	5	5	5
Max. output current	[A_{eff}]	24	10.35	30	24
Max. time	[s]	2	2	2	2
Max. output current	[A_{eff}]	32	13.8	40	32
Max. time	[s]	0.5	0.5	0.5	0.5

1) Option with FCT able to be parametrised

Tab. A.15 Output data CMMP-AS-C10-11A-P3-M3 with electrical rotation frequency ≥ 20 Hz

A.1.1 Interfaces

I/O interface [X1]

Digital I/O modules		Values	Comment
Inputs DIN0 ... DIN9	Input voltage [V]	24	active high, conforming to EN 61131-2
	Voltage range [V]	8 ... 30	
Outputs DOUT 0 ...	Output voltage [V]	24	active high, galvanically separated
	Voltage range ¹⁾ [V]	8 ... 30	
DOUT3	Max. output current [mA]	100	per output
+24 V	Output voltage [V]	24	–
	Max. output current [mA]	100	
GND24	Voltage [V]	0	Reference potential for digital I/Os

1) With use as digital input (configuration with FCT)

Tab. A.16 Technical data: Digital inputs/outputs [X1]

Analogue inputs/outputs		Values	Comment
AIN0 #AIN0	Input section [V]	±10 differential	–
	Resolution Bit	16	
	Time delay [µs]	< 250	
	Max. input voltage [V]	30	
	R _I [kΩ]	30	
AIN1	Input section [V]	±10 Single-ended	This input can be optionally parametrised also as a digital input DIN12 with an 8 V trigger level. ¹⁾
	Resolution Bit	10	
	Time delay [µs]	< 250	
AIN2	Input section [V]	±10 Single-ended	This input can be optionally parametrised also as a digital input DIN13 with an 8 V trigger level. ¹⁾
	Resolution [Bit]	10	
	Time delay [µs]	< 250	
AOUT0, AOUT1	Output section [V]	±10	–
	Resolution [Bit]	9	
	Critical frequency [kHz]	1	
AGND	Voltage [V]	0	Reference potential
+VREF	Output section [V]	0 ... 10	Reference output for setpoint potentiometer

1) Configuration using FCT

Tab. A.17 Technical data: Analogue inputs/outputs [X1]

Resolver connection [X2A]

Resolver connection		Values	Meaning
S1 S3	Input voltage [Veff]	3.5	COSINE+
	Input frequency [kHz]	5 ... 10	
	Internal resistance R_i [k Ω]	> 5	COSINE-
S2 S4	Input voltage [Veff]	3.5	SINE+
	Input frequency [kHz]	5 ... 10	
	Internal resistance R_i [k Ω]	> 5	SINE-
R1 R2	Voltage [Veff]	7	Carrier signal
	Frequency [kHz]	5 ... 10	
	Output current [mAeff]	$I_A < 150$	
			GND
MT+	Voltage [V]	+ 3.3	Motor temperature sensor, N/C contact, PTC, KTY...
MT-	Internal resistance R_i [k Ω]	2	
			Reference potential for temperature sensor

Tab. A.18 Technical data: Resolver [X2A]

Parameter	Values
Transmission ratio	0.5
Carrier frequency [kHz]	5 ... 10
Excitation voltage [Veff]	7, short circuit proof
Excitation impedance [at 10 kHz] [Ω]	$\geq (20 + j20)$
Stator impedance [Ω]	$\leq (500 + j1000)$

Tab. A.19 Technical data: Resolver [X2A]

Parameter	Values
Resolution [Bit]	16
Signal detection time delay [μ s]	< 200
Speed resolution [min^{-1}]	approx. 4
Absolute accuracy of angle acquisition [']	< 5
max. speed [min^{-1}]	16000

Tab. A.20 Technical data: Resolver evaluation [X2A]

Encoder connection [X2B]

Parameter		Value	Comment
Encoder line count	[Lines/R]	1 ... 262144	can be parameterised
Angular resolution/ Interpolation	[Bit/period]	10	
Tracking signals			
A, B	[Vpp]	1	differential; 2.5 V offset
N	[Vpp]	0.2 ... 1	differential; 2.5 V offset
Commutator tracks A1, B1 (optional)	[Vpp]	1	differential; 2.5 V offset
Track signal input impedance	[Ω]	120	Differential input
Critical frequency f_{crit}			
High-resolution track	[kHz]	>300	
Commutation track	[kHz]	approx. 10	
Additional communication interface		EnDat (Heidenhain), HIPERFACE (Stegmann) and BiSS	
Output supply		Current-limited, regulation via sensor cable	
Voltage	[V]	5 or 12	switchable via software
Current	[mA]	max. 300	

Tab. A.21 Technical data: Encoder connection [X2B]

CAN bus [X4]

Communication interface	Values
CANopen controller	ISODIS 11898, Full CAN controller, max. 1M Baud
CANopen protocol	in accordance with CiA301 and CiA402

Tab. A.22 Technical data: CAN bus [X4]

Increment encoder input [X10]

Feature		Value	Comment
Number of lines	[Lines/R]	1 ... 2 ²⁸	can be parameterised
Track signals A, A#, B, B#, N, N#		in accordance with RS422 specification	
Maximum input frequency	[kHz]	1000	
Pulse direction interface CLK, CLK#, DIR, DIR#, RESET, RESET#		in accordance with RS422 specification	
Output			
Voltage	[V]	5	
Current	[mA]	max. 100	

Tab. A.23 Technical data: Incremental encoder input [X10]

Incremental encoder output [X11]

Feature		Value	Comment
Number of output lines	[Lines/R]	1 ... 8192, 16384	
Connection level		Differential in accordance with RS422 specification	
Track signals A, B, N		in accordance with RS422 specification	N track can be switched off
Output impedance $R_{o,diff}$	[Ω]	66	
Critical frequency f_{crit}	[MHz]	> 1.8	Lines/s
Output supply			
Voltage	[V]	5	
Current	[mA]	max. 100	

Tab. A.24 Technical data: Incremental encoder output [X11]

A.2 Technical data CAMC-...

CAMC-	D-E8A8	PB	EC	DN
Storage temperature	[°C]	-25 ... +75		
Operating temperature	[°C]	0 ... +50		
Air humidity, non-condensing	[%]	0 ... 90		
Permissible setup altitude above sea level	[m]	≤ 2000		
Dimensions (LxWxH)	[mm]	87x65x19	92x65x19	87x65x19
Weight	[g]	50	55	50

Tab. A.25 CAMC-... ambient conditions, dimensions and weight

CAMC-D-E8A8 – Digital inputs	
Number of inputs	8
Nominal voltage	[V DC] 24
Voltage range	[V DC] -30 ... +30
Detection “high”	[V DC] > 8
Detection “low”	[V DC] < 2
Hysteresis	[V DC] > 1
Input impedance	[kΩ] ≥ 4.7
Polarity protection up to	[V DC] -30
Switching delay up to Portpin (low-high transition)	[μs] < 100

Tab. A.26 CAMC-D-E8A8 – Digital inputs

CAMC-D-E8A8 – Digital outputs	
Number of outputs	8
Switch type	High-side switch
Nominal voltage	[V DC] 24
Voltage range	[V DC] +18 ... +30
Nominal output current	[mA] 100
Voltage loss at nominal output current	[V DC] ≤ 1
Residual current with switch OFF	[μA] < 100
Short circuit/overcurrent protection approx.	[mA] > 500
Switch-off temperature	[°C] > 150
Switching delay up to Portpin (low-high transition)	[μs] < 100

Tab. A.27 CAMC-D-E8A8 – Digital outputs

A.3 Supported encoders

Resolver			
Type	Protocol	Interface	Comment
Standard	–	[X2A]	Transmission ratio 0.5 ±10 %, excitation voltage 7 Vrms

Tab. A.28 Supported resolvers

Digital encoders			
Type	Protocol	Interface	Comment
Yaskawa Σ-encoder	Yaskawa OEM-protocol	[X2B]	Yaskawa Sigma-1 Type A

Tab. A.29 Supported digital encoders

Analogue encoders			
Type	Protocol	Interface	Comment
ROD 400 ERO 1200, 1300, 1400 ERN 100, 400, 1100, 1300	–	[X2B]	Heidenhain, encoder with zero impulse and reference signal

Tab. A.30 Supported analogue encoders

EnDat encoders			
Type	Protocol	Interface	Comment
ROC 400 ECI 1100, 1300 ECN 100, 400, 1100, 1300	EnDat 2.1 (01/21) EnDat 2.2 (22)	[X2B]	Heidenhain single-turn absolute encoder with/without analogue signal
ROQ 400 EQI 1100, 1300 EQN 100, 400, 1100, 1300	EnDat 2.1 (01/21) EnDat 2.2 (22)	[X2B]	Heidenhain multi-turn absolute encoder with/without analogue signal
LC 100, 400	EnDat 2.1 (01) EnDat 2.2 (22)	[X2B]	Heidenhain absolute length measurement equipment

Tab. A.31 Supported EnDat encoders

HIPERFACE encoders			
Type	Protocol	Interface	Comment
SCS60, 70 SCM60, 70	Hiperface	[X2B]	Stegmann single-/multi-turn encoder with analogue incremental signal sine/cosine periods 512. Max. revolutions multi-turn: ±2048 R
SRS 50, 60, 64 SCKxx SRM 50, 60, 64 SCLxx	Hiperface	[X2B]	Stegmann single-/multi-turn encoder with analogue incremental signals. Sine/cosine periods 1024. Max. revolutions multi-turn: ±2048 R
SKS36 SKM36	Hiperface	[X2B]	Stegmann single-/multi-turn encoder with analogue incremental signals. Sine/cosine periods 128. Max. revolutions multi-turn: ±2048 R
SEK37, 52 SEL37, 52	Hiperface	[X2B]	Stegmann single-/multi-turn encoder with analogue incremental signals. Sine/cosine periods 16. Max. revolutions multi-turn: ±2048 R
L230	Hiperface	[X2B]	Stegmann absolute linear encoder with analogue incremental signal measurement step: 156.25 µm. Measuring length max. approx. 40 m.

Tab. A.32 Supported HIPERFACE encoders

BiSS encoder			
Type	Protocol	Interface	Comment
ME 20.20-0.40	BiSS	[X2B]	ELGO magnetic incremental linear encoder (use e.g. for ELGL-LAS...)

Tab. A.33 Supported BiSS encoders

B Diagnostic messages

If an error occurs, the motor controller CMMP-AS-...-M3 shows a diagnostic message cyclically in the 7-segment display. An error message consists of an E (for Error), a main index and sub-index, e.g.: - **E 0 1 0** -. Warnings have the same number as an error message. In contrast to error messages, however, warnings are preceded and followed by hyphens, e.g. - **1 7 0** -.

B.1 Explanations of the diagnostic messages

The following table summarises the significance of the diagnostic messages and the actions to be taken in response to them:

Terms	Meaning
No.	Main index (error group) and sub-index of the diagnostic message. Shown in the display, in FCT or diagnostic memory via FHPP.
Code	The Code column includes the error code (Hex) via CiA 301.
Message	Message that is displayed in the FCT.
Cause	Possible causes for the message.
Action	Action by the user.
Reaction	The Reaction column includes the error response (default setting, partially configurable): <ul style="list-style-type: none"> - PS off (switch off output stage), - MCStop (fast stop with maximum current), - QStop (fast stop with parameterised edge), - Warn (warning), - Ignore (No message, only entry in diagnostic memory), - NoLog (No message and no entry in diagnostic memory).

Tab. B.1 Explanations of the diagnostic messages

A complete list of the diagnostic messages corresponding to the firmware statuses at the time of printing of this document can be found in section B.2.

B.2 Diagnostic messages with instructions for fault clearance

Error group 0		Information	
No.	Code	Message	Reaction
0-0	-	Invalid error	
		Cause	Information: An invalid error entry (corrupted) was found in the diagnostic memory marked with this error number. The system time entry is set to 0.
		Measure	–
0-1	-	Invalid error detected and corrected	
		Cause	Information: An invalid error entry (corrupted) was found in the diagnostic memory and corrected. The additional information contains the original error number. The system time entry includes the address of the corrupted error number.
		Measure	–
0-2	-	Error cleared	
		Cause	Information: Active errors were acknowledged.
		Measure	–
0-4	-	Serial number / type of equipment (module replacement)	
		Cause	Information: → Diagnostic memory entry.
		Action	–
0-7	-	Subsequent entry	
		Cause	Information: → Diagnostic memory entry.
		Action	–
0-8	-	Controller switched on	
		Cause	Information: → Diagnostic memory entry.
		Action	–
0-9	-	Controller safety parameters changed	
		Cause	Information: → Diagnostic memory entry.
		Action	–
0-10	-	Safety module: Parameter changed	
		Cause	Information: → Diagnostic memory entry.
		Action	–
0-11	-	Module change: Previous module	
		Cause	Information: → Diagnostic memory entry.
		Action	–
0-12	-	Module change: Current module	
		Cause	Information: → Diagnostic memory entry.
		Action	–
0-13	-	Safety module: Error acknowledged	
		Cause	Information: → Diagnostic memory entry.
		Action	–

Error group 0		Information	
No.	Code	Message	Reaction
0-14	-	Safety function requested	
		Cause	Information: → Diagnostic memory entry.
		Action	–
0-15	-	Safety module: Parameterisation session started	
		Cause	Information: → Diagnostic memory entry.
		Action	–
0-16	-	Safety module: Parameterisation session closed	
		Cause	Information: → Diagnostic memory entry.
		Action	–
0-17	-	Safety module: Password changed	
		Cause	Information: → Diagnostic memory entry.
		Action	–
0-18	-	Safety module: Password reset	
		Cause	Information: → Diagnostic memory entry.
		Action	–
0-19	-	Safety module: Parameter record loaded	
		Cause	Information: → Diagnostic memory entry.
		Action	–
0-20	-	Safety module: Parameter record saved	
		Cause	Information: → Diagnostic memory entry.
		Action	–
0-21	-	Log entry from the safety module	
		Cause	Information: → Diagnostic memory entry.
		Action	–

Error group 1		Stack overflow	
No.	Code	Message	Reaction
1-0	6180h	Stack overflow	
		Cause	– Incorrect firmware? – Sporadic high processor load due to cycle time being too short and specific processor-intensive processes (save parameter set etc.).
		Action	<ul style="list-style-type: none"> • Load an approved firmware. • Reduce the processor load. • Contact Technical Support.
			PSoff

Error group 2		Undervoltage in intermediate circuit	
No.	Code	Message	Reaction
2-0	3220h	Undervoltage in intermediate circuit	
		Cause	Intermediate circuit voltage falls below the parameterised threshold (→ Additional information). Error priority set too high?
		Action	<ul style="list-style-type: none"> • Quick discharge due to switched-off mains supply. • Check power supply. • Couple intermediate circuits if technically permissible. • Check intermediate circuit voltage (measure). • Check undervoltage monitor (threshold value).
Additional info	Additional information in PNU 203/213: Upper 16 bits: Status number of internal state machine Bottom 16 bits: Intermediate circuit voltage (internal scaling approx. 17.1 digit/V).		

Error group 3		Motor overtemperature	
No.	Code	Message	Reaction
3-0	4310h	Analogue motor overtemperature	
		Cause	Motor overloaded, temperature too high. – Motor too hot? – Incorrect sensor? – Sensor defective? – Cable fracture?
		Action	<ul style="list-style-type: none"> • Check parameters (current regulator, current limits). • Check the parametrisation of the sensor or the sensor characteristics. If the error persists when the sensor is bypassed: Device defective.
3-1	4310h	Digital motor overtemperature	
		Cause	– Motor overloaded, temperature too high. – Suitable sensor or sensor characteristics parametrised? – Sensor defective?
		Action	<ul style="list-style-type: none"> • Check parameters (current regulator, current limits). • Check the parametrisation of the sensor or the sensor characteristics. If the error persists when the sensor is bypassed: Device defective.
3-2	4310h	Analogue motor overtemperature: Broken wire	
		Cause	The measured resistance value is above the threshold for wire break detection.
		Action	<ul style="list-style-type: none"> • Check the connecting cables of the temperature sensor for wire breaks. • Check the parametrisation (threshold value) for wire break detection.

Error group 3		Motor overtemperature	
No.	Code	Message	Reaction
3-3	4310h	Analogue motor overtemperature: Short circuit	
			configurable
		Cause	The measured resistance value is below the threshold for short circuit detection.
	Action	<ul style="list-style-type: none"> • Check the connecting cables of the temperature sensor for wire breaks. • Check the parametrisation (threshold value) for short circuit detection. 	

Error group 4		Intermediate circuit/power unit over-temperature	
No.	Code	Message	Reaction
4-0	4210h	Power end stage over-temperature	
			configurable
		Cause	Device is overheated <ul style="list-style-type: none"> – Temperature display plausible? – Device fan defective? – Device overloaded?
	Action	<ul style="list-style-type: none"> • Check installation conditions; are the control cabinet fan filters dirty? • Check the drive layout (due to possible overloading in continuous duty). 	
4-1	4280h	Intermediate circuit overtemperature	
			configurable
		Cause	Device is overheated <ul style="list-style-type: none"> – Temperature display plausible? – Device fan defective? – Device overloaded?
	Action	<ul style="list-style-type: none"> • Check installation conditions; are the control cabinet fan filters dirty? • Check the drive layout (due to possible overloading in continuous duty). 	

Error group 5		Internal power supply	
No.	Code	Message	Reaction
5-0	5114h	Failure of internal voltage 1	
			PSoff
		Cause	Monitoring of the internal power supply has recognised under-voltage. This is either due to an internal defect or an overload/short circuit caused by connected peripherals.
	Action	<ul style="list-style-type: none"> • Check digital outputs and brake output for short circuit or specified load. • Separate device from the entire peripheral equipment and check whether the error is still present after reset. If so, an internal defect is present → Repair by the manufacturer. 	

Error group 5		Internal power supply	
No.	Code	Message	Reaction
5-1	5115h	Failure of internal voltage 2	
		Cause	Monitoring of the internal power supply has recognised under-voltage. This is either due to an internal defect or an overload/ short circuit caused by connected peripherals.
		Action	<ul style="list-style-type: none"> • Check digital outputs and brake output for short circuit or specified load. • Separate device from the entire peripheral equipment and check whether the error is still present after reset. If so, an internal defect is present → Repair by the manufacturer.
5-2	5116h	Failure of driver supply	
		Cause	Monitoring of the internal power supply has recognised under-voltage. This is either due to an internal defect or an overload/ short circuit caused by connected peripherals.
		Action	<ul style="list-style-type: none"> • Check digital outputs and brake output for short circuit or specified load. • Separate device from the entire peripheral equipment and check whether the error is still present after reset. If so, an internal defect is present → Repair by the manufacturer.
5-3	5410h	Undervoltage of digital I/O	
		Cause	Overloading of the I/Os? Defective peripheral device?
		Action	<ul style="list-style-type: none"> • Check connected peripherals for short circuit / rated loads. • Check connection of the brake (connected incorrectly?).
5-4	5410h	Over-current of digital I/O	
		Cause	Overloading of the I/Os? Defective peripheral device?
		Action	<ul style="list-style-type: none"> • Check connected peripherals for short circuit / rated loads. • Check connection of the brake (connected incorrectly?).
5-5	-	Voltage failure of module in Ext1/Ext2	
		Cause	Defect on the plugged-in interface.
		Action	<ul style="list-style-type: none"> • Interface replacement → Repair by the manufacturer.
5-6	-	X10, X11 and RS232 supply voltage failure	
		Cause	Overloading through connected peripherals.
		Action	<ul style="list-style-type: none"> • Check pin allocation of the connected peripherals. • Short circuit?
5-7	-	Safety module internal voltage failure	
		Cause	Defect on the safety module.
		Action	<ul style="list-style-type: none"> • Internal defect → Repair by the manufacturer.

B Diagnostic messages

Error group 5		Internal power supply	
No.	Code	Message	Reaction
5-8	-	Failure of internal voltage 3 (15 V)	
		Cause	Defect in the motor controller.
		Action	<ul style="list-style-type: none"> Internal defect → Repair by the manufacturer.
5-9	-	Encoder supply defective	
		Cause	Back measurement of the encoder voltage not OK.
		Action	<ul style="list-style-type: none"> Internal defect → Repair by the manufacturer.

Error group 6		Overload current	
No.	Code	Message	Reaction
6-0	2320h	Output stage short circuit	
			PSoff
		Cause	<ul style="list-style-type: none"> – Faulty motor, e.g. winding short circuit due to motor overheating or short to PE inside motor. – Short circuit in the cable or the connecting plugs, i.e. short circuit between motor phases or to the screening/PE. – Output stage defective (short circuit). – Incorrect parameterisation of the current regulator.
		Action	Dependent on the status of the system → Additional information, cases a) to f).
	Additional info	<p>Actions:</p> <p>a) Error only with active brake chopper: Check external braking resistor for short circuit or insufficient resistance value. Check circuitry of the brake chopper output at the motor controller (bridge, etc.).</p> <p>b) Error message immediately when the power supply is connected: Internal short circuit in the output stage (short circuit of a complete half-bridge). The motor controller can no longer be connected to the power supply; the internal (and possibly external) fuses are tripped. Repair by the manufacturer required.</p> <p>c) Short circuit error message not until the output stage or controller is enabled.</p> <p>d) Disconnection of motor plug [X6] directly at the motor controller. If the error still occurs, there is a fault in the motor controller. Repair by the manufacturer required.</p> <p>e) If the error only occurs when the motor cable is connected: Check the motor and cable for short circuits, e.g. with a multimeter.</p> <p>f) Check parameterisation of the current regulator. Oscillations in an incorrectly parameterised current regulator can generate currents up to the short circuit threshold, usually clearly audible as a high-frequency whistling. Verification, if necessary, with the trace in the FCT (actual active current value).</p>	
6-1	2320h	Brake chopper overcurrent	
			PSoff
		Cause	Overload current at the brake chopper output.
	Action	<ul style="list-style-type: none"> • Check external braking resistor for short circuit or insufficient resistance value. • Check circuitry of the brake chopper output at the motor controller (bridge, etc.). 	

Error group 7		Overvoltage in intermediate circuit	
No.	Code	Message	Reaction
7-0	3210h	Overvoltage in intermediate circuit	
			PSoff
		Cause	Braking resistor is overloaded; too much braking energy, which cannot be dissipated quickly enough. <ul style="list-style-type: none"> – Resistor capacity is incorrect? – Resistor not connected correctly? – Check design (application).
	Action	<ul style="list-style-type: none"> • Check the design of the braking resistor; resistance value may be too great. • Check the connection to the braking resistor (internal/external). 	

Error group 8		Angle encoder	
No.	Code	Message	Reaction
8-0	7380h	Resolver angular encoder error	
			configurable
		Cause	Resolver signal amplitude is faulty.
		Action	Step-by-step procedure → Additional information, cases a) to c).
	Additional info	<p>a) If possible, test with a different (error-free) resolver (replace the connecting cable, too). If the error still occurs, there is a fault in the motor controller. Repair by the manufacturer required.</p> <p>b) If the error occurs only with a special resolver and its connecting cable: Check resolver signals (carrier and SIN/COS signal), see specification. If the signals do not comply with the signal specifications, replace the resolver.</p> <p>c) If the error recurs sporadically, check the screen bonding or check whether the resolver simply has an insufficient transmission ratio (standard resolver: A = 0.5).</p>	

Error group 8		Angle encoder	
No.	Code	Message	Reaction
8-1	-	Sense of rotation of the serial and incremental position evaluation is not identical	
		Cause	Only encoders with serial position transmission combined with an analogue SIN/COS signal track: The directions of rotation for position determination in the encoder and for incremental evaluation of the analogue track system in the motor controller are the wrong way round → Additional information.
		Action	Swap the following signals on the [X2B] angle encoder interface (the wires in the connecting plug must be changed around), observing the technical data for the angle encoder where applicable: <ul style="list-style-type: none"> – Swap SIN/COS track. – Swap the SIN+/SIN- or COS+/COS- signals, as applicable.
		Additional information	The encoder counts internally, for example positively in clockwise rotation, while the incremental evaluation counts in negative direction with the same mechanical rotation. The interchange of the direction of rotation is detected mechanically at the first movement of over 30°, and the error is triggered.
8-2	7382h	Error in incremental encoder tracking signals Z0	
		Cause	Signal amplitude of the Z0 track at [X2B] is faulty. <ul style="list-style-type: none"> – Angle encoder connected? – Angle encoder cable defective? – Angle encoder defective?
		Measure	Check configuration of angle encoder interface: <ol style="list-style-type: none"> a) Z0 evaluation activated, but no track signals connected or present → Additional information. b) Encoder signals faulty? c) Test with another encoder. → Tab. B.2, page 138.
		Additional information	For example, EnDat 2.2 or EnDat 2.1 without analogue track. Heidenhain encoder: Order codes EnDat 22 and EnDat 21. With these encoders there are no incremental signals, even when the cables are connected.

Error group 8		Angle encoder	
No.	Code	Message	Reaction
8-3	7383h	Error in incremental encoder tracking signals Z1	
			configurable
		Cause	Signal amplitude of the Z1 track at X2B is faulty. <ul style="list-style-type: none"> – Angle encoder connected? – Angle encoder cable defective? – Angle encoder defective?
		Measure	Check configuration of angle encoder interface: a) Z1 evaluation activated but not connected. b) Encoder signals faulty? c) Test with another encoder. → Tab. B.2, page 138.
8-4	7384h	Digital incremental encoder track signals error [X2B]	
			configurable
		Cause	Faulty A, B, or N track signals at [X2B]. <ul style="list-style-type: none"> – Angle encoder connected? – Angle encoder cable defective? – Angle encoder defective?
		Measure	Check the configuration of the angle encoder interface. b) Encoder signals faulty? b) Test with another encoder. → Tab. B.2, page 138.
8-5	7385h	Error in incremental encoder of Hall-effect encoder signals	
			configurable
		Cause	Hall encoder signals of a dig. Inc. at [X2B] faulty. <ul style="list-style-type: none"> – Angle encoder connected? – Angle encoder cable defective? – Angle encoder defective?
		Measure	Check the configuration of the angle encoder interface. b) Encoder signals faulty? b) Test with another encoder. → Tab. B.2, page 138.

Error group 8		Angle encoder	
No.	Code	Message	Reaction
8-6	7386h	Angle encoder communication fault	
			configurable
		Cause	<p>Communication to serial angle encoders is disrupted (EnDat encoders, HIPERFACE encoders, BiSS encoders).</p> <ul style="list-style-type: none"> – Angle encoder connected? – Angle encoder cable defective? – Angle encoder defective?
		Measure	<p>Check configuration of the angle encoder interface, procedure corresponding to a) to c):</p> <ul style="list-style-type: none"> a) Serial encoder parameterised but not connected? Incorrect serial protocol selected? b) Encoder signals faulty? c) Test with another encoder. <p>➔ Tab. B.2, page 138.</p>
8-7	7387h	Signal amplitude of incremental tracks faulty [X10]	
			configurable
		Cause	<p>Faulty A, B, or N track signals at [X10].</p> <ul style="list-style-type: none"> – Angle encoder connected? – Angle encoder cable defective? – Angle encoder defective?
		Measure	<p>Check the configuration of the angle encoder interface.</p> <ul style="list-style-type: none"> b) Encoder signals faulty? b) Test with another encoder. <p>➔ Tab. B.2, page 138.</p>
8-8	7388h	Internal angle encoder error	
			configurable
		Cause	<p>Internal monitoring of the angle encoder [X2B] has detected an error and forwarded it via serial communication to the controller.</p> <ul style="list-style-type: none"> – Declining illumination intensity with visual encoders? – Excess rotational speed? – Angle encoder defective?
		Measure	<p>If the error occurs repeatedly, the encoder is defective.</p> <p>➔ Replace encoder.</p>

Error group 8		Angle encoder	
No.	Code	Message	Reaction
8-9	7389h	Angle encoder at [X2B] is not supported	
			configurable
		Cause	<p>Angle encoder type read at [X2B], which is not supported or cannot be used in the desired operating mode.</p> <ul style="list-style-type: none"> – Incorrect or inappropriate protocol type selected? – Firmware does not support the connected encoder model?
		Action	<p>Depending on the additional information of the error message</p> <p>➔ Additional information:</p> <ul style="list-style-type: none"> • Load appropriate firmware. • Check/correct the configuration for encoder evaluation. • Connect an appropriate encoder type.
Additional information	<p>Additional info (PNU 203/213):</p> <p>0001: HIPERFACE: Encoder type is not supported by the firmware ➔ Connect another encoder type or load more recent firmware, if applicable.</p> <p>0002: EnDat: The address space in which the encoder parameter would have to lie does not exist with the connected EnDat encoder ➔ Check the encoder type.</p> <p>0003: EnDat: Encoder type is not supported by the firmware ➔ Connect another encoder type or load more recent firmware, if applicable.</p> <p>0004: EnDat: Encoder rating plate cannot be read from the connected encoder. ➔ Replace encoder or load more recent firmware, if applicable.</p> <p>0005: EnDat: EnDat 2.2 interface parameterised, but connected encoder supports only EnDat 2.1. ➔ Change encoder type or reparameterise to EnDat 2.1.</p> <p>0006: EnDat: EnDat2.1 interface with analogue track evaluation parameterised, but according to rating plate the connected encoder does not support track signals. ➔ Replace encoder or switch off Z0 track signal evaluation.</p> <p>0007: Code length measuring system with EnDat2.1 connected, but parameterised as a purely serial encoder. Purely serial evaluation is not possible due to the long response times of this encoder system. Encoder must be operated with analogue tracking signal evaluation ➔ Connect to analogue Z0 tracking signal evaluation.</p>		

Error group 9		Angle encoder parameter set	
No.	Code	Message	Reaction
9-0	73A1h	Old angle encoder parameter set	
		Cause	Warning: An encoder parameter record in an old format was found in the EEPROM of the connected encoder. This has now been converted and saved again.
		Measure	No activity at this point. The warning should not re-appear when the 24 V supply is switched back on.
9-1	73A2h	Angle encoder parameter record cannot be decoded	
		Cause	Data in the EEPROM of the angle encoder could not be read completely, or access to it was partly refused.
		Measure	The EEPROM of the encoder contains data (communication objects) which are not supported by the loaded firmware. The data in question is then discarded. <ul style="list-style-type: none"> • The parameter record can be adapted to the current firmware by writing the encoder data to the encoder. • Alternatively, load appropriate (more recent) firmware.
9-2	73A3h	Unknown version of angle encoder parameter record	
		Cause	The data saved in EEPROM is not compatible with the current version. A data structure was found which is unable to decode the loaded firmware.
		Action	<ul style="list-style-type: none"> • Save the encoder parameters again in order to delete the parameter record in the encoder and replace it with a readable record (this will, however, delete the data in the encoder irreversibly). • Alternatively, load appropriate (more recent) firmware.
9-3	73A4h	Defective data structure in angle encoder parameter record	
		Cause	Data in EEPROM does not match the stored data structure. The data structure was identified as valid but may be corrupted.
		Action	<ul style="list-style-type: none"> • Save the encoder parameters again in order to delete the parameter record in the encoder and replace it with a readable record. If the error still occurs after that, the encoder may be faulty. • Replace the encoder as a test.

Error group 9		Angle encoder parameter set	
No.	Code	Message	Reaction
9-4	-	EEPROM data: Erroneous custom specific configuration	configurable
		Cause	Only with specialised motors: The plausibility check returns an error, e.g. because the motor was repaired or exchanged.
		Action	<ul style="list-style-type: none"> • If motor repaired: Carry out homing again and save in the angle encoder, after that (!) save in the motor controller. • If motor exchanged: Parameterise the controller again, then carry out homing again and save in the angle encoder, after that (!) save in the motor controller.
9-7	73A5h	Write-protected EEPROM angle encoder	configurable
		Cause	Data cannot be saved in the EEPROM of the angle encoder. Occurs with Hiperface encoders.
		Measure	A data field in the encoder EEPROM is read-only (e.g. after operation on a motor controller of another manufacturer). No solution possible, encoder memory must be unlocked with a corresponding parameterisation tool (from manufacturer).
9-8	-	Error in the parameter memory of the angle encoder	configurable
		Cause	Parameter memory of the angle encoder damaged.
		Action	<ul style="list-style-type: none"> • Perform automatic identification of the angle encoder.
9-9	73A6h	Angle encoder's EEPROM too small	configurable
		Cause	It is not possible to save all the data in the EEPROM of the angle encoder.
		Action	<ul style="list-style-type: none"> • Reduce the number of data records to be saved. Please read the documentation or contact Technical Support.

Error group 10		Velocity Violation	
No.	Code	Message	Reaction
10-0	-	Speed exceeded	configurable
		Cause	<ul style="list-style-type: none"> – Motor racing (“spinning”) because the commutation angle offset is incorrect. – Motor is parametrised correctly but the limit for spinning protection is set too low.
		Action	<ul style="list-style-type: none"> • Check the commutation angle offset. • Check the limit value setting in the parameters.

Error group 11		Homing	
No.	Code	Message	Reaction
11-0	8A80h	Error when starting the homing run	
		Cause	Controller enable missing.
		Measure	Homing can only be started when closed-loop controller enable is active. <ul style="list-style-type: none"> • Check the condition or sequence.
11-1	8A81h	Error during homing	
		Cause	Homing was interrupted, e.g. by: <ul style="list-style-type: none"> – Withdrawal of controller enable. – Reference switch is beyond the limit switch. – External stop signal (a phase was aborted during homing).
		Action	<ul style="list-style-type: none"> • Check homing sequence. • Check arrangement of the switches. • If applicable, lock the stop input during homing if it is not desired.
11-2	8A82h	Homing: No valid index pulse	
		Cause	Required zero impulse during homing missing.
		Action	<ul style="list-style-type: none"> • Check the zero impulse signal. • Check the angle encoder settings.
11-3	8A83h	Homing: Timeout	
		Cause	The parameterised maximum time for the homing run was exceeded before homing was completed.
		Action	<ul style="list-style-type: none"> • Check the time setting in the parameters.
11-4	8A84h	Homing: Incorrect limit switch	
		Cause	<ul style="list-style-type: none"> – Relevant limit switch not connected. – Limit switches swapped? – No reference switch found between the two limit switches. – Reference switch is at the limit switch. – Current position with zero impulse method: Limit switch active in the area of the zero impulse (not permissible). – Both limit switches active at the same time.
		Action	<ul style="list-style-type: none"> • Check whether the limit switches are connected in the correct direction of travel or whether the limit switches have an effect on the intended inputs. • Reference switch connected? • Check configuration of the reference switches. • Move limit switch so that it is not in the zero pulse area. • Check limit switch parametrisation (N/C contact/N/O contact).

Error group 11		Homing	
No.	Code	Message	Reaction
11-5	8A85h	Homing: I²t / following error	
		Cause	<ul style="list-style-type: none"> – Acceleration ramps inappropriately parametrised. – Reversing due to premature triggering of following error; check parametrisation of following error. – No reference switch reached between the end stops. – Zero pulse method: End stop reached (here not permissible).
		Action	<ul style="list-style-type: none"> • Parametrise the acceleration ramps so they are flatter. • Check connection of a reference switch. • Method appropriate for the application?
11-6	8A86h	Homing: End of search path	
		Cause	The maximum permissible path for the homing run has been travelled without reaching the point of reference or the homing run destination.
		Measure	Malfunction in switch detection. <ul style="list-style-type: none"> • Switch for homing is defective?
11-7	-	Homing: Error in encoder difference monitoring	
		Cause	Deviation between the actual position value and commutation position is too great. External angle encoder not connected or faulty?
		Action	<ul style="list-style-type: none"> • Deviation fluctuates, e.g. due to gear backlash; cut-off threshold may need to be increased. • Check connection of the actual value encoder.

Error group 12		CAN communication	
No.	Code	Message	Reaction
12-0	8180h	CAN: Double node number	
		Cause	Node number assigned twice.
		Action	<ul style="list-style-type: none"> • Check the configuration of the participants on the CAN bus.
12-1	8120h	CAN: Communication error, bus OFF	
		Cause	The CAN chip has switched off communication due to communication errors (BUS OFF).
		Action	<ul style="list-style-type: none"> • Check wiring: Cable specification adhered to, broken cable, maximum cable length exceeded, correct terminating resistors, cable screening earthed, all signals terminated? • Replace device on a test basis. If a different device works without errors with the same cabling, send the device to the manufacturer for inspection.

Error group 12		CAN communication	
No.	Code	Message	Reaction
12-2	8181h	CAN: Communication error during transmission	
		Cause	The signals are corrupted when transmitting messages. Device boot up is so fast that no other nodes on the bus have yet been detected when the boot-up message is sent.
		Action	<ul style="list-style-type: none"> • Check wiring: Cable specification adhered to, broken cable, maximum cable length exceeded, correct terminating resistors, cable screening earthed, all signals terminated? • Replace device on a test basis. If a different device works without errors with the same cabling, send the device to the manufacturer for inspection.
12-3	8182h	CAN: Communication error during reception	
		Cause	The signals are corrupted when receiving messages.
		Action	<ul style="list-style-type: none"> • Check wiring: Cable specification adhered to, broken cable, maximum cable length exceeded, correct terminating resistors, cable screening earthed, all signals terminated? • Replace device on a test basis. If a different device works without errors with the same cabling, send the device to the manufacturer for inspection.
12-4	-	Node guarding telegram not received	
		Cause	Node guarding telegram not received within the parametrised time. Signals corrupted?
		Action	<ul style="list-style-type: none"> • Compare cycle time of the remote frames with that of the controller. • Check: Failure of the controller?
12-5	-	CAN: RPDO too short	
		Cause	A received RPDO does not contain the parameterised number of bytes.
		Measure	The number of parametrised bytes does not match the number of bytes received. <ul style="list-style-type: none"> • Check the parametrisation and correct.
12-9	-	CAN: Protocol error	
		Cause	Faulty bus protocol.
		Action	<ul style="list-style-type: none"> • Check the parametrisation of the selected CAN bus protocol.

Error group 13		CAN bus timeout	
No.	Code	Message	Reaction
13-0	-	CAN: Timeout	
		Cause	Error message from manufacturer-specific protocol.
		Action	<ul style="list-style-type: none"> • Check the CAN parameters.

Error group 14		Identification	
No.	Code	Message	Reaction
14-0	-	Automatic identification of the current regulator: Insufficient intermediate circuit voltage	PSoff
		Cause	Current regulator parameters cannot be determined (insufficient supply).
		Measure	The available intermediate circuit voltage is too low to carry out the measurement.
14-1	-	Automatic identification of the current regulator: Measurement cycle insufficient	PSoff
		Cause	Too few or too many measurement cycles required for the connected motor.
		Measure	Automatic determination of parameters has supplied a time constant outside the parameterisable value range. <ul style="list-style-type: none"> The parameters must be manually optimised.
14-2	-	Automatic identification of the current regulator: Output stage enable could not be issued	PSoff
		Cause	The output stage has not been enabled.
		Action	<ul style="list-style-type: none"> Check the connection of DIN4.
14-3	-	Automatic identification of the current regulator: Output stage was switched off prematurely	PSoff
		Cause	Output stage enable was switched off while identification was in progress.
		Action	<ul style="list-style-type: none"> Check the sequence control.
14-5	-	Automatic identification of the angle encoder: Zero impulse could not be found	PSoff
		Cause	The zero impulse could not be found following execution of the maximum permissible number of electrical revolutions.
		Action	<ul style="list-style-type: none"> Check the index pulse signal. Angle encoder parametrised correctly?
14-6	-	Automatic identification of the angle encoder: Hall signals invalid	PSoff
		Cause	Hall signals faulty or invalid. The pulse train and/or segmenting of the Hall signals is inappropriate.
		Action	<ul style="list-style-type: none"> Check connection. Refer to the technical data to check whether the encoder shows three Hall signals with 1205 or 605 segments; if necessary, contact Technical Support.

Error group 14		Identification	
No.	Code	Message	Reaction
14-7	-	Automatic identification of the angle encoder: Identification not possible	PSoff
		Cause	Angle encoder at a standstill.
		Action	<ul style="list-style-type: none"> • Ensure sufficient intermediate circuit voltage. • Encoder cable connected to the right motor? • Motor blocked, e.g. holding brake does not release?
14-8	-	Automatic identification of the angle encoder: Invalid number of pole pairs	PSoff
		Cause	The calculated number of pole pairs lies outside the parameterisable range.
		Action	<ul style="list-style-type: none"> • Compare result with the technical data specifications for the motor. • Check the parametrised number of lines.

Error group 15		Invalid operation	
No.	Code	Message	Reaction
15-0	6185h	Division by zero	PSoff
		Cause	Internal firmware error. Division by 0 when using the math library.
		Action	<ul style="list-style-type: none"> • Load factory settings. • Check the firmware to make sure that released firmware has been loaded.
15-1	6186h	Mathematical overflow during division	PSoff
		Cause	Internal firmware error. Overflow when using the math library.
		Action	<ul style="list-style-type: none"> • Load factory settings. • Check the firmware to make sure that released firmware has been loaded.
15-2	-	Mathematical underflow	PSoff
		Cause	Internal firmware error. Internal correction factors could not be calculated.
		Action	<ul style="list-style-type: none"> • Check the setting of the factor group for extreme values and change if necessary.

Error group 16		Internal error	
No.	Code	Message	Reaction
16-0	6181h	Error in program execution	PSoff
		Cause	Internal firmware error. Error during program execution. Illegal CPU command found in the program sequence.
		Action	<ul style="list-style-type: none"> • In case of repetition, load firmware again. If the error occurs repeatedly, the hardware is defective.

Error group 16		Internal error	
No.	Code	Message	Reaction
16-1	6182h	Illegal interrupt	
		Cause	Error during program execution. An unused IRQ vector was used by the CPU.
		Action	<ul style="list-style-type: none"> In case of repetition, load firmware again. If the error occurs repeatedly, the hardware is defective.
16-2	6187h	Initialisation error	
		Cause	Error in initialising the default parameters.
		Action	<ul style="list-style-type: none"> In case of repetition, load firmware again. If the error occurs repeatedly, the hardware is defective.
16-3	6183h	Unexpected state	
		Cause	Error during periphery access within the CPU or error in the program sequence (illegal branching in case structures).
		Action	<ul style="list-style-type: none"> In case of repetition, load firmware again. If the error occurs repeatedly, the hardware is defective.

Error group 17		Contouring error limit value exceeded	
No.	Code	Message	Reaction
17-0	8611h	Contouring error limit value exceeded	
		Cause	Comparison threshold for the limit value of the following error exceeded.
		Action	<ul style="list-style-type: none"> Enlarge error window. Parameterise acceleration to be less. Motor overloaded (current limiter from the I²t monitoring active?).
17-1	8611h	Encoder difference monitoring	
		Cause	Deviation between the actual position value and commutation position is too great. External angle encoder not connected or faulty?
		Action	<ul style="list-style-type: none"> Deviation fluctuates, e.g. due to gear backlash; cut-off threshold may need to be increased. Check connection of the actual value encoder.

Error group 18		Temperature warning threshold	
No.	Code	Message	Reaction
18-0	-	Analogue motor temperature	
		Cause	Motor temperature (analogue) greater than 5° below T _{max} .
		Action	<ul style="list-style-type: none"> Check parametrisation of current regulator and/or speed regulator. Motor permanently overloaded?

Error group 21		Current measurement	
No.	Code	Message	Reaction
21-0	5280h	Error 1 current measurement U	
		Cause	Offset for current measurement 1 phase U is too great. The controller carries out offset compensation of the current measurement every time its controller enable is issued. Tolerances that are too large result in an error.
		Action	If the error occurs repeatedly, the hardware is defective.
21-1	5281h	Error 1 current measurement V	
		Cause	Offset for current measurement 1 phase V is too great.
		Measure	If the error occurs repeatedly, the hardware is defective.
21-2	5282h	Error 2 current measurement U	
		Cause	Offset for current measurement 2 phase U is too great.
		Measure	If the error occurs repeatedly, the hardware is defective.
21-3	5283h	Error 2 current measurement V	
		Cause	Offset for current measurement 2 phase V is too great.
		Measure	If the error occurs repeatedly, the hardware is defective.

Error group 22		PROFIBUS	
No.	Code	Message	Reaction
22-0	-	PROFIBUS: Initialization error	
		Cause	Faulty initialization of the PROFIBUS interface. Interface faulty?
		Action	<ul style="list-style-type: none"> Replace interface. Repair by the manufacturer may be an option.
22-2	-	PROFIBUS: Faulty communication	
		Cause	Malfunctions in communication.
		Action	<ul style="list-style-type: none"> Check the slave address set. Check bus termination. Check wiring.
22-3	-	PROFIBUS: Invalid slave address	
		Cause	Communication was started with slave address 126.
		Action	<ul style="list-style-type: none"> Select a different slave address.
22-4	-	PROFIBUS: Conversion error	
		Cause	During conversion with the factor group, the range of values was exceeded. Mathematical error in the conversion of the physical units.
		Action	<ul style="list-style-type: none"> The range of values of the data and the physical units do not match. Check and correct.

Error group 25		type of equipment/equipment function	
No.	Code	Message	Reaction
25-0	6080h	Invalid type of equipment	
		Cause	Device coding not recognised or invalid.
		Measure	This fault cannot be fixed by the user. <ul style="list-style-type: none"> Send motor controller to the manufacturer.
25-1	6081h	type of equipment not supported	
		Cause	Device coding invalid, is not supported by the loaded firmware.
		Action	<ul style="list-style-type: none"> Load up-to-date firmware. If newer firmware is not available, the problem may be a hardware defect. Send motor controller to the manufacturer.
25-2	6082h	Invalid hardware revision	
		Cause	The controller's hardware version is not supported by the loaded firmware.
		Action	<ul style="list-style-type: none"> Check the firmware version; update the firmware to a more recent version if necessary.
25-3	6083h	Device with restricted functionality: Firmware cannot be executed	
		Cause	Device is not enabled for this function.
		Measure	Device is not unlocked for the desired functionality and may need to be unlocked by the manufacturer. The device must be sent in for this purpose.
25-4	-	Invalid power stage type	
		Cause	<ul style="list-style-type: none"> Power section area in the EEPROM is unprogrammed. Power section is not supported by the firmware.
		Action	<ul style="list-style-type: none"> Load appropriate firmware.
25-5	-	FW/HW incompatibility	
		Cause	<ul style="list-style-type: none"> Incorrect firmware?
		Action	<ul style="list-style-type: none"> Load an approved firmware. Contact Technical Support.

Error group 26		Internal data error	
No.	Code	Message	Reaction
26-0	5580h	Missing user parameter set	
		Cause	No valid user parameter set in the flash memory.
		Action	<ul style="list-style-type: none"> Load factory settings. If the error remains, the hardware may be defective.
26-1	5581h	Checksum error	
		Cause	Checksum error of a parameter set.
		Action	<ul style="list-style-type: none"> Load factory settings. If the error remains, the hardware may be defective.

Error group 26		Internal data error	
No.	Code	Message	Reaction
26-2	5582h	Flash: Error when writing	
		Cause	Error when writing the internal flash memory.
		Action	<ul style="list-style-type: none"> Execute the last operation again. If the error appears again, the hardware may be faulty.
26-3	5583h	Flash: Error during deletion	
		Cause	Error during deletion of the internal flash memory.
		Action	<ul style="list-style-type: none"> Execute the last operation again. If the error appears again, the hardware may be faulty.
26-4	5584h	Flash: Error in internal flash	
		Cause	The default parameter set is corrupted / data error in the FLASH area where the default parameter set is located.
		Action	<ul style="list-style-type: none"> Load firmware again. If the error appears again, the hardware may be faulty.
26-5	5585h	Missing calibration data	
		Cause	Factory-set calibration parameters incomplete/corrupted.
		Action	This fault cannot be fixed by the user.
26-6	5586h	Missing position data sets	
		Cause	Position data sets incomplete or corrupt.
		Action	<ul style="list-style-type: none"> Load factory settings or save the current parameters again so that the position data is written again.
26-7	-	Fault in data tables (CAM)	
		Cause	Data for the cam disk is corrupted.
		Action	<ul style="list-style-type: none"> Load factory settings. Reload the parameter set if necessary. If the error persists, contact Technical Support.

Error group 27		Following error monitoring	
No.	Code	Message	Reaction
27-0	8611h	Following error warning threshold	
		Cause	<ul style="list-style-type: none"> Motor overloaded? Check motor capacity. Acceleration or braking ramps are set too steep. Motor blocked? Commutation angle correct?
		Action	<ul style="list-style-type: none"> Check the parametrisation of the motor data. Check parametrisation of the following error.

Error group 28		Operating hours counter	
No.	Code	Message	Reaction
28-0	FF01h	Missing operating hour counter	
		Cause	No record for an operating hour counter could be found in the parameter block. A new operating hour counter was created. Occurs during initial commissioning or a processor change.
		Measure	Warning only, no further action required.
28-1	FF02h	Operating hour counter: Write error	
		Cause	The data block in which the operating hour counter is stored could not be written to. Cause unknown; possibly problems with the hardware.
		Measure	Warning only, no further action required. If the error occurs again, the hardware may be faulty.
28-2	FF03h	Operating hour counter corrected	
		Cause	The operating hour counter has a backup copy. If the controller's 24 V power supply fails precisely when the operating hour counter is being updated, the written record may be corrupted. In such cases, the controller restores the hours-run meter from the intact backup copy when it restarts.
		Measure	Warning only, no further action required.
28-3	FF04h	Operating hour counter converted	
		Cause	Firmware was loaded in which the operating hour counter has a different data format. The next time the controller is switched on, the old hours-run meter record is converted to the new format.
		Action	Warning only, no further action required.

Error group 29		Memory card	
No.	Code	Message	Reaction
29-0	-	Memory card not present	
		Cause	This error is triggered in the following cases: <ul style="list-style-type: none"> – if an action should be carried out on the memory card (load or create DCO file, firmware download), but no memory card is plugged in. – The DIL switch S3 is set to ON but no card is plugged in after the reset/restart.
		Measure	Insert appropriate memory card in the slot. Only if expressly desired!

Error group 29		Memory card	
No.	Code	Message	Reaction
29-1	-	Memory card: Initialisation error	
		Cause	This error is triggered in the following cases: <ul style="list-style-type: none"> – The memory card could not be initialised. Card type may not be supported! – File system not supported. – Error in relationship with the shared memory.
		Action	<ul style="list-style-type: none"> • Check card type used. • Connect memory card to a PC and format again.
29-2	-	Memory card: Data error	
		Cause	This error is triggered in the following cases: <ul style="list-style-type: none"> – A load or storage process is already running, but a new load or storage process is requested. DCO file » Servo – The DCO file to be loaded has not been found. – The DCO file to be loaded is not appropriate for the device. – The DCO file to be loaded is defective. – Servo » DCO file – The memory card is read-only. – Other error while saving the parameter set as a DCO file. – Error in creating the file INFO.TXT.
		Action	<ul style="list-style-type: none"> • Execute load or storage process again after waiting 5 seconds. • Connect memory card to a PC and check the files included. • Remove write protection from the memory card.
29-3	-	Memory card: Write error	
		Cause	<ul style="list-style-type: none"> – This error is triggered while saving the DCO file or INFO.TXT file if the memory card is discovered to be already full. – The maximum file index (99) already exists. That is, all file indexes are assigned. No filename can be issued!
		Action	<ul style="list-style-type: none"> • Insert another memory card. • Change filenames.

Error group 29		Memory card	
No.	Code	Message	Reaction
29-4	-	Memory card: Firmware download error	
		Cause	This error is triggered in the following cases: <ul style="list-style-type: none"> - No firmware file on the memory card. - The firmware file is not appropriate for the device. - Other error during firmware download, e.g. checksum error with an SRecord, error with flash memory, etc.
		Action	<ul style="list-style-type: none"> • Connect memory card to PC and transfer firmware file.

Error group 30		Internal conversion error	
No.	Code	Message	Reaction
30-0	6380h	Internal conversion error	
		Cause	Range exceeded for internal scaling factors, which are dependent on the parametrised controller cycle times.
		Action	<ul style="list-style-type: none"> • Check whether extremely short or extremely long cycle times were parametrised.

Error group 31		I ² t monitoring	
No.	Code	Message	Reaction
31-0	2312h	Motor I²t	
		Cause	I ² t monitoring of the controller has been triggered. <ul style="list-style-type: none"> - Motor/mechanical system blocked or sluggish. - Motor under-sized?
		Action	<ul style="list-style-type: none"> • Check power dimensioning of drive package.
31-1	2311h	I²t-servo controller	
		Cause	The I ² t monitoring is responding frequently. <ul style="list-style-type: none"> - Motor controller under-sized? - Mechanics stiff?
		Action	<ul style="list-style-type: none"> • Check project engineering of the motor controller, • possibly use a more powerful type. • Check the mechanical system.
31-2	2313h	I²t-PFC	
		Cause	PFC power rating exceeded.
		Action	<ul style="list-style-type: none"> • Parameterise operation without PFC (using FCT).
31-3	2314h	Braking resistor I²t	
		Cause	- Overloading of the internal braking resistor.
		Action	<ul style="list-style-type: none"> • Use external braking resistor. • Reduce resistance value or use resistor with higher pulse load.

Error group 32		Intermediate circuit	
No.	Code	Message	Reaction
32-0	3280h	Intermediate circuit charging time exceeded	
			configurable
		Cause	The intermediate circuit could not be charged after the mains voltage was applied. <ul style="list-style-type: none"> – Fuse possibly defective or – Internal braking resistor defective or – In operation with external resistor, the resistor is not connected.
Action	<ul style="list-style-type: none"> • Check interface to the external braking resistor. • Alternatively, check whether the jumper for the internal braking resistor is in place. <p>If the interface is correct, the internal braking resistor or the built-in fuse is probably faulty. On-site repair is not possible.</p>		
32-1	3281h	Undervoltage for active PFC	
			configurable
		Cause	The PFC cannot be activated at all until an intermediate circuit voltage of about 130 V DC is reached.
Action	<ul style="list-style-type: none"> • Check power supply. 		
32-5	3282h	Brake chopper overload	
			configurable
		Cause	The extent of utilisation of the brake chopper when quick discharge began was already in the range above 100 %. Quick discharge took the brake chopper to the maximum load limit and was prevented/aborted.
Measure	No action required.		
32-6	3283h	Intermediate circuit discharge time exceeded	
			configurable
		Cause	Intermediate circuit could not be quickly discharged. The internal braking resistor may be faulty or, in the case of operation with an external resistor, that resistor is not connected.
Action	<ul style="list-style-type: none"> • Check interface to the external braking resistor. • Alternatively, check whether the jumper for the internal braking resistor is in place. <p>If the internal resistor has been activated and the jumper has been positioned correctly, the internal braking resistor is probably faulty.</p>		
32-7	3284h	Power supply missing for controller enable	
			configurable
		Cause	Controller enable was issued when the intermediate circuit was still in its charging phase after mains voltage was applied and the mains relay was not yet activated. The drive cannot be enabled in this phase, because the drive is not yet firmly connected to the mains (through the mains relay).
Action	<ul style="list-style-type: none"> • In the application, check whether the mains supply and controller enable signals were sent one quickly after the other. 		

Error group 32		Intermediate circuit	
No.	Code	Message	Reaction
32-8	3285h	Power supply failure during controller enable	
		Cause	Interruptions / failure in the power supply while the controller enable was activated.
		Action	<ul style="list-style-type: none"> • Check power supply.
32-9	3286h	Phase failure	
		Cause	Failure of one or more phases (only in the case of three-phase supply).
		Action	<ul style="list-style-type: none"> • Check power supply.

Error group 33		Encoder emulation following error	
No.	Code	Message	Reaction
33-0	8A87h	Encoder emulation following error	
		Cause	The critical frequency for encoder emulation was exceeded (see manual) and the emulated angle at [X11] was no longer able to follow. Can occur if very high numbers of lines are programmed for [X11] and the drive reaches high speeds.
		Action	<ul style="list-style-type: none"> • Check whether the parametrised number of lines may be too high for the speed being represented. • Reduce the number of lines if necessary.

Error group 34		Fieldbus synchronisation	
No.	Code	Message	Reaction
34-0	8780h	No synchronisation via fieldbus	
		Cause	When activating the interpolated position mode, the controller could not be synchronised to the fieldbus. <ul style="list-style-type: none"> – The synchronisation messages from the master may have failed or – the IPO interval is not correctly set to the synchronisation interval of the fieldbus.
		Action	<ul style="list-style-type: none"> • Check the settings for the controller cycle times.
34-1	8781h	Fieldbus synchronization error	
		Cause	<ul style="list-style-type: none"> – Synchronisation via fieldbus messages during ongoing operation (interpolated position mode) has failed. – Synchronisation messages from master failed? – Synchronisation interval (IPO interval) parametrised too small/ too large?
		Action	<ul style="list-style-type: none"> • Check the settings for the controller cycle times.

Error group 35		Linear motor	
No.	Code	Message	Reaction
35-0	8480h	Linear motor spinning protection	
		Cause	Encoder signals are corrupt. The motor may be racing (“spinning”) because the commutation position has been shifted by the faulty encoder signals.
		Action	<ul style="list-style-type: none"> • Check that the installation conforms to the EMC recommendations. • In the case of linear motors with inductive/optical encoders with separately mounted measuring tape and measuring head: Check the mechanical clearance. • In the case of linear motors with inductive encoders, make sure that the magnetic field of the magnets or the motor winding does not leak into the measuring head (this effect usually occurs when high accelerations = high motor current).
35-5	-	Error during determination of the commutation position	
		Cause	The rotor position could not be identified clearly. <ul style="list-style-type: none"> – The selected method may be inappropriate. – The selected motor current for the identification may not be set appropriately.
		Action	<ul style="list-style-type: none"> • Check the method for determining the commutation position ➔ Additional information.
	Additional info	Notes on determining the commutation position: <ol style="list-style-type: none"> a) The alignment method is inappropriate for locked or sluggish drives or drives capable of low-frequency oscillation. b) The microstep method is appropriate for air-core and iron-core motors. As only very small movements are carried out, it works even when the drive is on elastic stops or is locked but can still be moved elastically to some extent. Due to the high excitation frequency, however, the method is very susceptible to oscillations in the case of poorly damped drives. In such cases, you can attempt to reduce the excitation current (%). c) The saturation method uses local occurrences of saturation in the iron of the motor. Recommended for locked drives. Air-core drives are by definition not suitable for this method. If the (iron-core) drive moves too much when locating the commutation position, the measurement result may be adulterated. If this is the case, reduce the excitation current. In the opposite case, if the drive does not move, the excitation current may not be strong enough, causing the saturation to be insufficient. 	

Error group 36		Parameter	
No.	Code	Message	Reaction
36-0	6320h	Parameter was limited	
		Cause	An attempt was made to write a value which was outside the permitted limits, so the value was limited.
		Action	<ul style="list-style-type: none"> • Check the user parameter record.
36-1	6320h	Parameter was not accepted	
		Cause	An attempt was made to write to an object which is “read only” or is not write-capable in the current status (e.g. with controller enable active).
		Action	<ul style="list-style-type: none"> • Check the user parameter record.

Error group 40		Software end positions	
No.	Code	Message	Reaction
40-0	8612h	Negative software end position reached	
		Cause	The position setpoint value has reached or exceeded the negative software limit switch.
		Action	<ul style="list-style-type: none"> • Check target data. • Check positioning area.
40-1	8612h	Positive software end position reached	
		Cause	The position setpoint value has reached or exceeded the positive software limit switch.
		Action	<ul style="list-style-type: none"> • Check target data. • Check positioning area.
40-2	8612h	Positioning beyond negative software end position suppressed	
		Cause	Start of a positioning task was suppressed because the target lies behind the negative software limit switch.
		Action	<ul style="list-style-type: none"> • Check target data. • Check positioning area.
40-3	8612h	Positioning beyond positive software end position suppressed	
		Cause	The start of a positioning task was suppressed because the target lies behind the positive software limit switch.
		Action	<ul style="list-style-type: none"> • Check target data. • Check positioning area.

Error group 41		Record linking	
No.	Code	Message	Reaction
41-0	-	Record linking: Synchronisation error	
		Cause	Start of synchronisation without prior sampling pulse.
		Action	<ul style="list-style-type: none"> • Check the parametrisation of the pre-stop path.

Error group 42		Positioning	
No.	Code	Message	Reaction
42-0	8680h	Positioning: The drive stops automatically because there is no follow-up positioning	configurable
		Cause	The positioning target cannot be reached through the positioning or edge condition options.
		Action	<ul style="list-style-type: none"> • Check parametrisation of the position records in question.
42-1	8681h	Positioning: Drive stops as rotation reversal is not allowed	configurable
		Cause	The positioning target cannot be reached through the positioning or edge condition options.
		Action	<ul style="list-style-type: none"> • Check parametrisation of the position records in question.
42-2	8682h	Positioning: Illegal rotation reversal after “stop”	configurable
		Cause	The positioning target cannot be reached through the positioning or edge condition options.
		Action	<ul style="list-style-type: none"> • Check parametrisation of the position records in question.
42-3	-	Start positioning rejected: Wrong operating mode	configurable
		Cause	Reversing of the operating mode by means of the position record was not possible.
		Action	<ul style="list-style-type: none"> • Check parametrisation of the position records in question.
42-4	-	Homing required	configurable
		Cause	A normal positioning set was started, but the drive needs a valid reference position before starting.
		Action	<ul style="list-style-type: none"> • Execute new homing.
42-5	-	Modulo positioning: Direction of rotation not allowed	configurable
		Cause	<ul style="list-style-type: none"> – The positioning target cannot be reached through the positioning or edge condition options. – The calculated direction of rotation is not permitted for the modulo positioning in the set mode.
		Action	<ul style="list-style-type: none"> • Check the chosen mode.
42-9	-	Error when starting the positioning task	configurable
		Cause	<ul style="list-style-type: none"> – Acceleration limit value exceeded. – Position record blocked.
		Action	<ul style="list-style-type: none"> • Check parameterisation and sequence control and correct, if necessary.

Error group 43		Hardware limit switch	
No.	Code	Message	Reaction
43-0	8081h	Limit switch: Negative setpoint value blocked	configurable
		Cause	Negative hardware limit switch reached.
		Action	<ul style="list-style-type: none"> • Check parametrisation, wiring and limit switches.

Error group 43		Hardware limit switch	
No.	Code	Message	Reaction
43-1	8082h	Limit switch: Positive setpoint value blocked	
		Cause	Positive hardware limit switch reached.
		Action	<ul style="list-style-type: none"> • Check parametrisation, wiring and limit switches.
43-2	8083h	Limit switch: Positioning suppressed	
		Cause	<ul style="list-style-type: none"> – The drive has left the intended range of motion. – Technical defect in the system?
		Action	<ul style="list-style-type: none"> • Check the intended range of motion.

Error group 44		Cam disks	
No.	Code	Message	Reaction
44-0	-	Fault in the cam disc tables	
		Cause	The cam disc to be started is not available.
		Action	<ul style="list-style-type: none"> • Check transferred cam disc no. • Correct parametrisation. • Correct programming.
44-1	-	Cam disc: General error homing	
		Cause	– Start of a cam disc, but the drive is not yet referenced.
		Action	<ul style="list-style-type: none"> • Carry out a homing run.
		Cause	– Start of homing with active cam disc.
		Action	<ul style="list-style-type: none"> • Deactivate cam disk. Then restart cam disc, if necessary.

Error group 47		Setting up	
No.	Code	Message	Reaction
47-0	-	Setting-up timeout	
		Cause	The speed required for setting-up was not fallen below in time.
		Measure	Check processing of the request on the control side.

Error group 48		Homing required	
No.	Code	Message	Reaction
48-0	-	Homing required	
		Cause	An attempt is being made to switch to the speed control or torque control operating mode or to issue the controller enable in one of these operating modes, although the drive requires a valid reference position for this.
		Action	<ul style="list-style-type: none"> • Carry out a homing run.

Error group 50		CAN communication	
No.	Code	Message	Reaction
50-0	-	Too many synchronous PDOs	
		Cause	More PDOs have been activated than can be processed in the underlying SYNC interval. This message also appears if only one PDO is to be transmitted synchronously, but a high number of other PDOs with a different transmission type have been activated.
		Action	<ul style="list-style-type: none"> • Check the activation of PDOs. If the configuration is appropriate, the warning can be suppressed using error management. <ul style="list-style-type: none"> • Extend the synchronisation interval.
50-1	-	SDO errors have occurred	
		Cause	An SDO transfer has caused an SDO abort. <ul style="list-style-type: none"> – Data exceeds the range of values. – Access to non-existent object.
		Action	<ul style="list-style-type: none"> • Check the command sent.

Error group 51		Safety module/function	
No.	Code	Message	Reaction
51-0	8091h	No/unknown safety module or driver supply faulty	
		Cause	Internal voltage error of the safety module or micro switch module.
		Action	<ul style="list-style-type: none"> • Module presumably defective. If possible, replace with another module.
		Cause	No safety module detected or unknown module type.
51-1	8092h	Safety function: Driver supply is faulty	
		Cause	Internal hardware error (voltage error) of the safety module or micro switch module.
		Action	<ul style="list-style-type: none"> • Module presumably defective. If possible, replace with another module.
		Cause	– Error in driver circuit section in the basic unit.
		Action	<ul style="list-style-type: none"> • Basic unit presumably defective. If possible, replace with another basic unit.

Error group 51		Safety module/function	
No.	Code	Message	Reaction
51-2	8093h	Safety module: Unequal module type	
		Cause	Type or revision of the module does not fit the project planning.
		Action	<ul style="list-style-type: none"> • Check whether correct module type and correct revision are being used. • With module replacement: Module type not yet designed. Accept currently integrated safety or micro switch module.
51-3	8094h	Safety module: Unequal module version	
		Cause	Type or revision of the module is not supported.
		Action	<ul style="list-style-type: none"> • Install safety or switch module appropriate for the firmware and hardware. • Load firmware appropriate for the module, see type designation on the module.
		Cause	The module type is correct but the module version is not supported by the basic unit.
		Action	<ul style="list-style-type: none"> • Check module version; if possible use module of same version after replacement. Install suitable safety or micro switch module for the firmware and hardware. • If only a module with a more recent version is available: Load firmware that is appropriate for the module; see type designation on the module.
51-4	8095h	Safety module: Error in SSIO communication	
		Cause	Fault in the internal communication connection between the basic unit and the safety module.
		Action	<ul style="list-style-type: none"> • This error may occur if a CAMC-G-S3 was designed into the basic unit but a different module type was plugged in. • Load firmware appropriate for the safety or micro switch module, see type designation on the module.
51-5	8096h	Safety module: Error in brake control	
		Cause	Internal hardware error (brake activation control signals) of the safety module or micro switch module.
		Action	<ul style="list-style-type: none"> • Module presumably defective. If possible, replace with another module.
		Cause	Error in brake driver circuit section in the basic unit.
		Action	<ul style="list-style-type: none"> • Basic unit presumably defective. If possible, replace with another basic unit.

Error group 51		Safety module/function	
No.	Code	Message	Reaction
51-6	8097h	Safety module: Non-identical module serial number	
		Cause	Serial number of currently connected safety module is different from the stored serial number.
		Action	Error only occurs after replacement of the CAMC-G-S3. <ul style="list-style-type: none"> With module replacement: Module type not yet designed. Accept currently integrated CAMC-G-S3.

Error group 52		Safety function	
No.	Code	Message	Reaction
52-1	8099h	Safety function: Discrepancy time overrun	
		Cause	– Control ports STO-A and STO-B are not actuated simultaneously.
		Action	• Check discrepancy time.
		Cause	– Control ports STO-A and STO-B are not wired in the same way.
		Action	• Check discrepancy time.
		Cause	Upper and lower switch supply not simultaneously activated (discrepancy time exceeded) <ul style="list-style-type: none"> – Error in control / external circuitry of safety module. – Error in safety module.
		Action	<ul style="list-style-type: none"> Check circuitry of the safety module – are the inputs STO-A and STO-B switched off on two channels and simultaneously? Replace safety module if you suspect it is faulty.
52-2	809Ah	Safety function: Failure of driver supply with active PWM control	
		Cause	This error message does not occur with equipment delivered from the factory. It can occur with use of a user-specific device firmware.
		Action	<ul style="list-style-type: none"> The safe status was requested with approved power output stage. Check inclusion in the safety-oriented interface.

Error group 52		Safety function	
No.	Code	Message	Reaction
52-3	809Bh	Safety module: Overlapping limits of rotational speed limitation in basic unit	
		Cause	Basic unit reports error if the currently requested direction of movement is not possible because the safety module has blocked the setpoint value in this direction. Error may occur in connection with the SSFx safe speed functions if an asymmetrical speed window is used where one limit is set to zero. In this case, the error occurs when the basic unit moves in the blocked direction in the Positioning mode.
		Action	<ul style="list-style-type: none"> Check application and change if necessary.

Error group 53		Violation of safety conditions	
No.	Code	Message	Reaction
53-0	80A1h	USF0: Safety condition violated	
		Cause	– Violation of monitored speed limits of the SSF0 in operation / when USF0 / SSF0 requested.
		Action	Check when the violation of the safety condition occurs: a) During dynamic braking to safe rotational speed b) After the drive has reached the safe speed. <ul style="list-style-type: none"> With a) Critical check of braking ramp – record trace - can the drive follow the ramp? Change parameters for the braking ramp or start time / delay times for monitoring. With b) Check how far the current speed is from the monitored limit speed; increase distance if necessary (parameter in safety module) or correct speed specified by controller.
53-1	80A2h	USF1: Safety condition violated	
		Cause	– Violation of monitored speed limits of the SSF1 in operation / when USF1 / SSF1 requested.
		Action	<ul style="list-style-type: none"> See USF0, error 53-0.
53-2	80A3h	USF2: Safety condition violated	
		Cause	– Violation of monitored speed limits of the SSF2 in operation / when USF2 / SSF2 requested.
		Action	<ul style="list-style-type: none"> See USF0, error 53-0.
53-3	80A4h	USF3: Safety condition violated	
		Cause	– Violation of monitored speed limits of the SSF3 in operation / when USF3 / SSF3 requested.
		Action	<ul style="list-style-type: none"> See USF0, error 53-0.

Error group 54		Violation of safety conditions	
No.	Code	Message	Reaction
54-0	80AAh	SBC: Safety Condition Violated	
		Cause	– Brake should engage; no feedback received within the expected time.
		Action	<ul style="list-style-type: none"> • Check how the feedback signal is configured – was the correct input selected for the feedback signal? • Does the feedback signal have the correct polarity? • Check whether the feedback signal is actually switching. • Is the parameterised delay time for the evaluation of the feedback signal appropriate to the brake used (measure switching time if necessary)?
54-2	80ACh	SS2: Safety Condition Violated	
		Cause	– Actual speed outside permitted limits for too long.
		Action	<p>Check when the violation of the safety condition occurs:</p> <p>a) During dynamic braking to zero.</p> <p>b) After the drive has reached zero speed.</p> <ul style="list-style-type: none"> • With a) Critical check of braking ramp – record trace - can the drive follow the ramp? Change parameters for the braking ramp or start time / delay times for monitoring. • With a) If the option Trigger basic unit quick stop is activated: Critical check of the basic unit's quick stop ramp. • With b) Check whether the drive continues to oscillate after reaching the zero speed or remains still and stable – increase monitoring tolerance time if necessary. • With b) If the actual speed value is very noisy at rest. Check and if necessary adjust expert parameters for speed recording and detection of standstill.
54-3	80ADh	SOS: Safety Condition Violated	
		Cause	<ul style="list-style-type: none"> – Angle encoder evaluation reports “Motor running” (actual speed exceeds limit). – Drive has rotated out of its position since reaching the safe state.
		Action	<ul style="list-style-type: none"> • Check the position tolerance for the SOS monitoring and increase if necessary, if this is permissible. • If the actual speed value is very noisy when at rest: Check and if necessary adjust expert parameters for speed recording and detection of standstill.

Error group 54		Violation of safety conditions	
No.	Code	Message	Reaction
54-4	80AEh	SS1: Safety Condition Violated	
		Cause	– Actual speed outside permitted limits for too long.
		Action	<p>Check when the violation of the safety condition occurs:</p> <p>a) During dynamic braking to zero.</p> <p>b) After the drive has reached zero speed.</p> <ul style="list-style-type: none"> • With a) Critical check of braking ramp – record trace - can the drive follow the ramp? Change parameters for the braking ramp or start time / delay times for monitoring. • With a) If the option Trigger basic unit quick stop is activated: Critical check of the basic unit's quick stop ramp. • With b) Check whether the drive continues to oscillate after reaching the zero speed or remains still and stable – increase monitoring tolerance time if necessary. • With b) If the actual speed value is very noisy when at rest: Check and if necessary adjust expert parameters for speed recording and detection of standstill.
54-5	80AFh	STO: Safety Condition Violated	
		Cause	– Internal hardware error (voltage error) of the safety module.
		Action	• Module presumably defective. If possible, replace with another module.
		Cause	– Error in driver circuit section in the basic unit.
		Action	• Basic unit presumably defective. If possible, replace with another basic unit.
		Cause	– No feedback received from basic unit to indicate that output stage was switched off.
Action	• Check whether the error can be acknowledged and whether it occurs again upon a new STO request – if yes: Basic unit is presumably faulty. If possible, replace with another basic unit.		

Error group 54		Violation of safety conditions	
No.	Code	Message	Reaction
54-6	80B0h	SBC: Brake not vented for > 24 hrs	configurable
		Cause	– Error occurs when SBC is requested and the brake has not been opened by the basic unit in the last 24 hours.
		Action	<ul style="list-style-type: none"> • If the brake is actuated via the brake driver in the basic unit [X6]: The brake must be energised at least once within 24 V before the SBC request because the circuit breaker check can only be performed when the brake is switched on (energised). • Only if brake control takes place via DOUT4x and an external brake controller: Deactivate 24 hr monitoring in the SBC parameters if the external brake controller allows this.
54-7	80B1h	SOS: SOS > 24 hr requested	configurable
		Cause	– If SOS is requested for more than 24 hours, the error is triggered.
		Action	• Terminate SOS occasionally; move axis once occasionally.

Error group 55		Measuring of actual value 1	
No.	Code	Message	Reaction
55-0	80C1h	No actual rotational speed / position value available or stand-still > 24 hrs	configurable
		Cause	<ul style="list-style-type: none"> – Subsequent error when a position encoder fails. – Safety function SSF, SS1, SS2 or SOS requested and actual rotational speed value is not valid.
		Action	• Check the function of the position encoder(s) (see following error).
55-1	80C2h	SINCOS encoder [X2B] - Tracking signal error	configurable
		Cause	<ul style="list-style-type: none"> – Vector length $\sin^2 + \cos^2$ is outside the permissible range. – The amplitude of one of the two signals is outside the permissible range. – Offset between analogue and digital signal is greater than 1 quadrant.
		Action	<p>Error may occur with SIN/COS and Hiperface encoders.</p> <ul style="list-style-type: none"> • Check the position encoder. • Check the connection wiring (broken wire, short between two signals or signal / screening). • Check the supply voltage for the position encoder. • Check the motor cable / screening on motor and drive side – EMC malfunctions may trigger the error.

Error group 55		Measuring of actual value 1	
No.	Code	Message	Reaction
55-2	80C3h	SINCOS encoder [X2B] - Standstill > 24 hrs	
		Cause	<ul style="list-style-type: none"> - Input signals of the SinCos encoder have not changed by a minimum amount for 24 hours (when safety function is requested).
		Action	<ul style="list-style-type: none"> • Terminate SS2 or SOS occasionally; move axis once occasionally.
55-3	80C4h	Resolver [X2A] - Signal error	
		Cause	<ul style="list-style-type: none"> - Vector length $\sin^2 + \cos^2$ is outside the permissible range. - The amplitude of one of the two signals is outside the permissible range. - Input signal is static (same values to right and left of maximum).
		Action	<ul style="list-style-type: none"> • Check the resolver. • Check the connection wiring (broken wire, short between two signals or signal / screening). • Check for a failure of the primary radiator signal • Check the motor and encoder cable / screening on motor and drive side. EMC malfunctions can trigger the error.
55-4	-	EnDat encoder [X2B] - Sensor error	
		Cause	<ul style="list-style-type: none"> - Communication error between safety module and the ENDAT encoder. - Error message of the ENDAT encoder present.
		Action	<ul style="list-style-type: none"> • Check the ENDAT encoder. • Check the connection wiring (broken wire, short between two signals or signal / screening). • Check the supply voltage for the ENDAT encoder. • Check the motor cable / screening on motor and drive side – EMC malfunctions may trigger the error.
55-5	-	EnDat encoder [X2B] - Incorrect sensor type	
		Cause	<ul style="list-style-type: none"> - Number of lines does not correspond to parameterisation. - Serial no. Does not correspond to parameterisation. - Sensor type does not correspond to parameterisation.
		Action	<ul style="list-style-type: none"> • Check the parametrizing. • Use only approved encoders.

Error group 55		Measuring of actual value 1	
No.	Code	Message	Reaction
55-6	80C5h	Incremental encoder [X10] - Tracking signal error	
		Cause	– Faulty tracking signals from incremental encoder.
		Action	<ul style="list-style-type: none"> • Check the connection wiring (broken wire, short between two signals or signal / screening). • Check the motor cable / screening on motor and drive side – EMC malfunctions may trigger the error.
55-7	80C6h	Other encoder [X2B] - Faulty angle information	
		Cause	<ul style="list-style-type: none"> – “Angle faulty” message is sent from basic unit when status lasts for longer than the allowed time. – Encoder at X2B is evaluated by the basic unit, – Encoder is faulty.
		Action	<ul style="list-style-type: none"> • Check the position encoder at X2B. • Check the connection wiring (broken wire, short between two signals or signal / screening). • Check the supply voltage for the ENDAT encoder. • Check the motor cable / screening on motor and drive side – EMC malfunctions may trigger the error.
55-8	-	Impermissible acceleration detected	
		Cause	<ul style="list-style-type: none"> – Error in connected position encoder. – EMC malfunctions affecting the position encoder. – Impermissible high acceleration rates in the movement profiles. – Acceleration limit parameterised too low. – Angle jump after reference movement in the position data transmitted from the basic unit to the safety module.
		Action	<ul style="list-style-type: none"> • Checking of the connected position encoder: If further error messages occur in connection with the encoders, then eliminate their cause first. • Check the motor and encoder cable / screening on motor and drive side. EMC malfunctions can trigger the error. • Checking of the setpoint specifications / Movement profiles of the controller: Do they contain impermissibly high temperatures above the limit value for acceleration monitoring (P06.07)? • Check whether the limit value for acceleration monitoring was parameterised correct - the limit value (P06.07) should be at least 30% ... 50% above the maximum acceleration actually occurring. • In case of an angle jump in the position data transmitted from the basic unit - Acknowledge error once.

Error group 56		Measuring of actual value 2	
No.	Code	Message	Reaction
56-8	80D1h	Rotational speed / angle difference, encoder 1 - 2	
		Cause	<ul style="list-style-type: none"> – Rotational speed difference between encoders 1 and 2 of one μC for longer than allowed time outside the permissible range. – Angle difference between encoders 1 and 2 of one μC for longer than allowed time outside the permissible range.
		Action	<ul style="list-style-type: none"> • Problem may occur if two position encoders are used in the system and they are not “rigidly coupled”. • Check for elasticity or looseness, improve mechanical system. • Adjust the expert parameters for the position comparison if this is acceptable from an application point of view.
56-9	-	Error, cross-comparison of encoder evaluation	
		Cause	Cross-comparison between $\mu\text{C}1$ and $\mu\text{C}2$ has detected an angle difference or rotational speed difference or difference in capture times for the position encoders.
		Action	<ul style="list-style-type: none"> • Timing disrupted. If the error occurs against after a reset, the safety module is presumably faulty.

Error group 57		Input/output error	
No.	Code	Message	Reaction
57-0	80E1h	Error, I/O self test (internal/external)	
			configurable
		<p>Cause</p> <ul style="list-style-type: none"> – Error at outputs DOUT40 ... DOUT42 (detection by test pulses). – Internal error of digital inputs DIN40 ... DIN49 (via internal test signals). – Error at brake output at X6 (signalling, detection by test pulses). – Internal error of brake output (via internal test signals). – Internal error of digital outputs DOUT40 – DOUT42 (via internal test signals). 	
		<p>Action</p> <ul style="list-style-type: none"> • Check the connection wiring for the digital outputs DOUT40 ... DOUT42 (short circuit, cross circuit, etc.). • Check the connection wiring for the brake (short circuit, cross circuit, etc.). • Brake connection: The error may occur with longer motor cables if: <ol style="list-style-type: none"> 1. The brake output X6 was configured for the brake (this is the case with factory settings!) and 2. A motor without a holding brake is used and the brake connection lines in the motor cable are terminated at X6. In this case: Disconnect the brake connection lines at X6. • If there is no error in the connection wiring, there may be an internal error in the module (check by swapping the module). 	
57-1	80E2h	Digital inputs - Signal level error	
			configurable
		<p>Cause</p> <p>Exceeding / violation of discrepancy time with multi-channel inputs (DIN40 ... DIN44, two-handed control device, mode selector switch).</p>	
		<p>Action</p> <ul style="list-style-type: none"> • Check the external active and passive sensors – do they switch on two channels and simultaneously (within the parameterised discrepancy time). • Two-handed operator device: Check how the device is operated by the user – are both pushbuttons pressed within the discrepancy time? Give training if necessary. • Check the set discrepancy times – are they sufficient? 	

Error group 57		Input/output error	
No.	Code	Message	Reaction
57-2	-	Digital inputs - Test pulse error	
			configurable
		Cause	– One or more inputs (DIN40 ... DIN49) were configured for the evaluation of the test pulses of the outputs (DOUT40 ... DOUT42). The test pulses from DOUTx do not arrive at DIN4x.
	Action	<ul style="list-style-type: none"> • Check the wiring (shorts after 0 V, 24 V, cross circuits). • Check the assignment – correct output selected / configured for test pulse? 	
57-6	-	Electronics temperature too high	
			configurable
		Cause	– The safety module's temperature monitor has been triggered; the temperature of $\mu C1$ or $\mu C2$ was below -20° or above $+75^{\circ}C$.
	Action	<ul style="list-style-type: none"> • Check the operating conditions (ambient temperature, control cabinet temperature, installation situation in the control cabinet). • If the motor controller is experiencing high thermal load (high control cabinet temperature, high power consumption / output to motor, large number of occupied slots), a motor controller of the next highest output level should be used. 	

Error group 58		Error during communication / parameterisation	
No.	Code	Message	Reaction
58-0	80E9h	Plausibility check of parameters	
			configurable
		Cause	The plausibility check in the safety module produced errors, e.g. an invalid angle encoder configuration; the error is triggered when a validation code is requested by the SafetyTool and when parameters are backed up in the safety module.
	Action	<ul style="list-style-type: none"> • Note instructions for SafetyTool for complete validation; critically check parameterisation. 	
58-1	-	General error, parameterisation	
			configurable
		Cause	Parameter session active for > 8 hrs. The safety module has thus terminated the parameterisation session The error message is saved in the diagnostic memory.
	Action	<ul style="list-style-type: none"> • Terminate parameterisation session within 8 hrs., if necessary, start a new parameterisation session after this and continue. 	

Error group 58		Error during communication / parameterisation	
No.	Code	Message	Reaction
58-4	80E9h	Buffer, internal communication	
		Cause	<ul style="list-style-type: none"> – Communication connection faulty. – Timeout / data error / incorrect sequence (packet counter) in data transmission between the basic unit and safety module. – Too much data traffic, new requests are being sent to safety module before old ones have been responded to.
		Action	<ul style="list-style-type: none"> • Check communication interfaces, wiring, screening, etc. • Check whether other devices have read access to the motor controller and safety module during a parameterisation session - this may overload the communication connection. • Check whether the firmware versions of the safety module and basic unit and the versions of the FCT PlugIn and SafetyTool are compatible.
58-5	80EAh	Communication module - basic unit	
		Cause	<ul style="list-style-type: none"> – Packet counter error during transmission $\mu C1 \leftrightarrow \mu C2$. – Checksum error during transmission $\mu C1 \leftrightarrow \mu C2$.
		Action	<ul style="list-style-type: none"> • Internal malfunction in the motor controller. • Check whether the firmware versions of the safety module and basic unit and the versions of the FCT PlugIn and SafetyTool are compatible.

Error group 58		Error during communication / parameterisation	
No.	Code	Message	Reaction
58-6	80EBh	Error in cross-comparison for processors 1 - 2	
		Fixed [8]	
		Cause	<p>Timeout during cross-comparison (no data) or cross-comparison faulty (data for μC1 and μC2 are different).</p> <ul style="list-style-type: none"> – Error in cross-comparison for digital IO. – Error in cross-comparison for analogue input. – Error in cross-comparison for internal operating voltage measurement (5 V, 3.3 V, 24 V) and reference voltage (2.5 V). – Error in cross-comparison for SIN/COS angle encoder analogue values. – Error in cross-comparison for programme sequence monitoring. – Error in cross-comparison for interrupt counter. – Error in cross-comparison for input map. – Error in cross-comparison for violation of safety conditions. – Error in cross-comparison for temperature measurement.
		Action	<p>This is an internal error in the module that should not occur during operation.</p> <ul style="list-style-type: none"> • Check the operating conditions (temperature, air humidity, condensation). • Check the EMC wiring as specified, screening concept, are there any external interference sources? • Safety module may be faulty – is error eliminated after replacing the module? • Check whether new firmware for the motor controller or a new version of the safety module is available from the manufacturer.

Error group 59		Internal safety module error	
No.	Code	Message	Reaction
59-1	80F1h	Fail-safe mode supply/safe pulse inhibitor	
		Fixed [8]	
		Cause	– Internal error in module in fail-safe mode supply circuit section or in the driver supply for the upper and lower switches.
		Action	• Module faulty, replace.
59-2	80F2h	Error external power supply	
		Fixed [8]	
		Cause	– Reference voltage 2.5 V outside tolerance. – Logic supply overvoltage +24 V detected.
		Action	• Module faulty, replace.
59-3	80F3h	Error internal power supply	
		Fixed [8]	
		Cause	– Voltage (internal 3.3 V, 5 V, ADU reference) outside the permissible range.
		Action	• Module faulty, replace.

Error group 59		Internal safety module error	
No.	Code	Message	Reaction
59-4	80F4h	Error management: Too many errors	
		Cause	– Too many errors have occurred simultaneously.
		Action	<ul style="list-style-type: none"> • Clarify: What is the status of the installed safety module - does it contain a valid parameter set? • Read out and analyse the log file of the basic unit via FCT. • Remedy causes of error step by step. • Install safety module with “delivery status” and perform commissioning of basic unit. • If this is not available: Set factory settings in the safety module, then copy data from the basic unit and perform complete validation. Check whether the error occurs again.
59-5	80F5h	Error writing to diagnostic memory	
		Cause	Subsequent error if internal communication is disrupted. – Basic unit not ready for operation, faulty or memory error.
		Action	<ul style="list-style-type: none"> • Check the basic unit for function • Generate an error in the basic unit, e.g. by unplugging the position encoder, and check whether the basic unit writes an entry to the log file. • Module or basic unit faulty; replace.
59-6	80F6h	Error on saving parameter set	
		Cause	– Voltage interruption / power off while parameters were being saved.
		Action	<ul style="list-style-type: none"> • Maintain a voltage supply of 24 V throughout the parameterisation session. • Once the error has occurred, parameterise the module again and validate the parameter set again.
59-7	80F7h	FLASH checksum error	
		Cause	<ul style="list-style-type: none"> – Voltage interruption / power off while parameters were being saved. – Flash memory in safety module corrupted (e.g. by extreme malfunctions).
		Action	Check whether the error recurs after a reset. If it does: <ul style="list-style-type: none"> • Parameterise the module again and validate the parameter set again. If error persists: • Module faulty, replace.

Error group 59		Internal safety module error	
No.	Code	Message	Reaction
59-8	80F8h	Internal monitoring, processor 1 - 2	
		Cause	<ul style="list-style-type: none"> – Serious internal error in the safety module: Error detected while dynamising internal signals – Disrupted programme sequence, stack error or OP code test failed, processor exception / interrupt.
		Action	Check whether the error recurs after a reset. If it does: <ul style="list-style-type: none"> • Module faulty, replace.
59-9	80F9h	Other unexpected error	
		Cause	Triggering of internal programme sequence monitoring.
		Action	<ul style="list-style-type: none"> • Check the firmware version of the basic unit and the version of the safety module – update available? • Safety module faulty; replace.

Error group 62		EtherCAT	
No.	Code	Message	Reaction
62-0	-	EtherCAT: General bus error	
		Cause	No EtherCAT bus present.
		Action	<ul style="list-style-type: none"> • Switch on the EtherCAT master. • Check wiring.
62-1	-	EtherCAT: Initialisation error	
		Cause	Error in the hardware.
		Action	<ul style="list-style-type: none"> • Replace the interface and send it to the manufacturer for checking.
62-2	-	EtherCAT: Protocol error	
		Cause	CAN over EtherCAT is not in use.
		Action	<ul style="list-style-type: none"> • Incorrect protocol. • EtherCAT bus cabling fault.
62-3	-	EtherCAT: Invalid RPDO length	
		Cause	Sync manager 2 buffer size is too large.
		Action	<ul style="list-style-type: none"> • Check the RPDO configuration of the motor controller and the higher-level control system.
62-4	-	EtherCAT: Invalid TPDO length	
		Cause	Sync manager 3 buffer size is too large.
		Action	<ul style="list-style-type: none"> • Check the TPDO configuration of the motor controller and the higher-level control system.
62-5	-	EtherCAT: Erroneous cyclic data transmission	
		Cause	Emergency shut-down due to failure of cyclic data transmission.
		Action	<ul style="list-style-type: none"> • Check the configuration of the master. Synchronous transmission is unstable.

Error group 63		EtherCAT	
No.	Code	Message	Reaction
63-0	-	EtherCAT: Defective module	
		Cause	Error in the hardware.
		Action	<ul style="list-style-type: none"> Replace the interface and send it to the manufacturer for checking.
63-1	-	EtherCAT: Invalid data	
		Cause	Faulty telegram type.
		Action	<ul style="list-style-type: none"> Check wiring.
63-2	-	EtherCAT: TPDO data has not been read	
		Cause	The buffer for sending the data is full.
		Measure	The data was sent faster than the motor controller could process it. <ul style="list-style-type: none"> Reduce the cycle time on the EtherCAT bus.
63-3	-	EtherCAT: No distributed clocks active	
		Cause	Warning: Firmware is synchronising with the telegram, not with the distributed clocks system. When the EtherCAT was started, no hardware SYNC (distributed clocks) was found. The firmware now synchronises with the EtherCAT frame.
		Action	<ul style="list-style-type: none"> If necessary, check whether the master supports the distributed clocks feature. Otherwise: Ensure that the EtherCAT frames are not interrupted by other frames if the “interpolated position mode” is to be used.
63-4	-	EtherCAT: Missing SYNC message in IPO cycle	
		Cause	Telegrams are not being sent in the time slot pattern of the IPO.
		Action	<ul style="list-style-type: none"> Check the participant responsible for distributed clocks.

Error group 64		DeviceNet	
No.	Code	Message	Reaction
64-0	-	DeviceNet: Duplicate MAC ID	
		Cause	The duplicate MAC-ID check has found two nodes with the same MAC-ID.
		Action	<ul style="list-style-type: none"> Change the MAC-ID of one of the nodes to a value which is not already used.
64-1	-	DeviceNet: Bus power lost	
		Cause	The DeviceNet interface is not supplied with 24 V DC.
		Action	<ul style="list-style-type: none"> In addition to the motor controller, the DeviceNet interface must also be connected to 24 V DC.
64-2	-	DeviceNet: Receive buffer overflow	
		Cause	Too many messages received within a short period.
		Action	<ul style="list-style-type: none"> Reduce the scan rate.

Error group 64		DeviceNet	
No.	Code	Message	Reaction
64-3	-	DeviceNet: Send buffer overflow	
		Cause	Insufficient free space on the CAN bus for sending messages.
		Action	<ul style="list-style-type: none"> • Increase the baud rate. • Reduce the number of nodes. • Reduce the scan rate.
64-4	-	DeviceNet: IO message not sent	
		Cause	Error sending I/O data.
		Action	<ul style="list-style-type: none"> • Check that the network is connected correctly and does not malfunction.
64-5	-	DeviceNet: Bus OFF	
		Cause	The CAN controller is BUS OFF.
		Action	<ul style="list-style-type: none"> • Check that the network is connected correctly and does not malfunction.
64-6	-	DeviceNet: CAN controller reports overflow	
		Cause	The CAN controller has an overrun.
		Action	<ul style="list-style-type: none"> • Increase the baud rate. • Reduce the number of nodes. • Reduce the scan rate.

Error group 65		DeviceNet	
No.	Code	Message	Reaction
65-0	-	DeviceNet activated, but no module	
		Cause	The DeviceNet communication is activated in the parameter set of the motor controller, but no interface is available.
		Action	<ul style="list-style-type: none"> • Deactivate the DeviceNet communication. • Connect an interface.
65-1	-	IO connection timeout	
		Cause	Interruption of an I/O connection.
		Action	<ul style="list-style-type: none"> • An I/O message is not received within the expected time.

Error group 66		Modbus/TCP	
No.	Code	Message	Reaction
66-0	-	Modbus/TCP: No free TCP/IP instances	
		Warn	
		Cause	Ethernet stack cannot provide the requested TCP connection. Internal device error.
		Action	<ul style="list-style-type: none"> Restart device or restore factory settings. If the error occurs repeatedly, the HW is faulty. It cannot be repaired on-site.

Error group 67		Modbus/TCP	
No.	Code	Message	Reaction
67-0	-	Modbus/TCP: Timeout TCP/IP	
		configurable	
		Cause	Existing TCP connection between host and controller has been disconnected.
		Action	<ul style="list-style-type: none"> Ethernet cable inserted correctly? Host switched off or no longer accessible?
67-1	-	Modbus/TCP: Timeout Modbus TCP/IP	
		configurable	
		Cause	TCP connection between host and controller exists, but the host no longer sends any data.
		Action	<ul style="list-style-type: none"> Host crashed?
67-2	-	Modbus/TCP: Buffer overflow	
		configurable	
		Cause	Internal buffer for processing the data is full. Data is sent from the host faster than the controller can process it.
		Action	<ul style="list-style-type: none"> Reduce the update time of the host.
67-3	-	Modbus/TCP: Telegram length too short	
		configurable	
		Cause	The data transmitted by the host is too short. Host sends less data than expected by the controller.
		Action	<ul style="list-style-type: none"> Correct the data length in the host.
67-4	-	Modbus/TCP: Telegram length too long	
		configurable	
		Cause	The data transmitted by the host is too long. Host sends more data than expected by the controller.
		Action	<ul style="list-style-type: none"> Correct the data length in the host.

Error group 68		EtherNet/IP	
No.	Code	Message	Reaction
68-0	-	EtherNet/IP: Serious error	configurable
		Cause	A serious internal error has occurred. This can be triggered, for example, by a defective interface.
		Action	<ul style="list-style-type: none"> • Try to acknowledge the error. • Carry out a reset. • Replace the interface. • If the error continues, contact Technical Support.
68-1	-	EtherNet/IP: General communication error	configurable
		Cause	A serious error was detected in the EtherNet/IP interface.
		Action	<ul style="list-style-type: none"> • Try to acknowledge the error. • Carry out a reset. • Replace the interface. • If the error continues, contact Technical Support.
68-2	-	EtherNet/IP: Connection has been closed	configurable
		Cause	The connection was closed via the controller.
		Measure	A new connection to the controller must be constructed.
68-3	-	EtherNet/IP: Connection interruption	configurable
		Cause	A connection interruption occurred during operation.
		Action	<ul style="list-style-type: none"> • Check the cabling between the motor controller and the controller. • Construct a new connection to the controller.
68-5	-	EtherNet/IP: Duplicate network address present	configurable
		Cause	At least one device with the same IP address exists in the network.
		Action	<ul style="list-style-type: none"> • Use unique IP addresses for all equipment in the network.

Error group 69		EtherNet/IP	
No.	Code	Message	Reaction
69-0	-	EtherNet/IP: Minor error	configurable
		Cause	A minor error was detected in the EtherNet/IP interface.
		Action	<ul style="list-style-type: none"> • Try to acknowledge the error. • Carry out a reset.
69-1	-	EtherNet/IP: Incorrect IP configuration	configurable
		Cause	An incorrect IP configuration has been detected.
		Action	<ul style="list-style-type: none"> • Correct the IP configuration.

Error group 69		EtherNet/IP	
No.	Code	Message	Reaction
69-2	-	EtherNet/IP: Fieldbus module not found	
		Cause	There is no EtherNet/IP interface in the slot.
		Action	<ul style="list-style-type: none"> • Check whether an EtherNet/IP interface is in the Ext2 slot.
69-3	-	EtherNet/IP: Module version not supported	
		Cause	There is an EtherNet/IP interface with incompatible version in the slot.
		Action	<ul style="list-style-type: none"> • Carry out a firmware update on the most current motor controller firmware.

Error group 70		FHPP protocol	
No.	Code	Message	Reaction
70-1	-	FHPP: Mathematical error	
		Cause	Overrun/underrun or division by zero during calculation of cyclic data.
		Action	<ul style="list-style-type: none"> • Check the cyclic data. • Check the factor group.
70-2	-	FHPP: Factor group invalid	
		Cause	Calculation of the factor group leads to invalid values.
		Action	<ul style="list-style-type: none"> • Check the factor group.
70-3	-	FHPP: Invalid operating mode change	
		Cause	Changing from the current to the desired operating mode is not permitted. <ul style="list-style-type: none"> – Error occurs when the OPM bits in the status S5 'Reaction to fault' or S4 'Operation enabled' are changed. – Exception: In the status SA1 'Ready', the change between 'Record select' and 'Direct Mode' is permissible.
		Action	<ul style="list-style-type: none"> • Check your application. It may be that not every change is permissible.

Error group 71		FHPP protocol	
No.	Code	Message	Reaction
71-1	-	FHPP: Wrong Receive Telegram Length	
		Cause	Too little data is being transmitted by the control system (data length too short).
		Action	<ul style="list-style-type: none"> • Check the data length parameterised in the control system for the controller's receive telegram. • Check the configured data length in the FHPP+ Editor of the FCT.

Error group 71		FHPP protocol	
No.	Code	Message	Reaction
71-2	-	FHPP: Wrong response telegram length	
		Cause	Too much data is to be transmitted from the motor controller to the control system (data length too great).
		Action	<ul style="list-style-type: none"> • Check the data length parameterised in the control system for the controller's receive telegram. • Check the configured data length in the FHPP+ Editor of the FCT.

Error group 72		PROFINET	
No.	Code	Message	Reaction
72-0	-	PROFINET: Initialisation error	
		Cause	Interface presumably includes an incompatible stack version or is defective.
		Action	<ul style="list-style-type: none"> • Replace interface.
72-1	-	PROFINET: Bus error	
		Cause	No communication possible (e.g. line removed).
		Action	<ul style="list-style-type: none"> • Check cabling • Start PROFINET communication again.
72-3	-	PROFINET: Invalid IP configuration	
		Cause	An invalid IP configuration was entered in the interface. The interface cannot start with this configuration.
		Action	<ul style="list-style-type: none"> • Parameterise a permissible IP configuration via FCT.
72-4	-	PROFINET: Invalid device name	
		Cause	A PROFINET device name was assigned with which the controller cannot communicate with the PROFINET (character specification from PROFINET standard).
		Action	<ul style="list-style-type: none"> • Parameterise a permissible PROFINET device name via FCT.
72-5	-	PROFINET: Module faulty	
		Cause	Interface CAMC-F-PN defective.
		Action	<ul style="list-style-type: none"> • Replace interface.
72-6	-	PROFINET: Indication invalid/not supported	
		Cause	A message is issued by the PROFINET interface that is not supported by the motor controller.
		Action	<ul style="list-style-type: none"> • Please contact Technical Support.

Error group 73		PROFINET	
No.	Code	Message	Reaction
73-0	-	PROFenergy: Status not possible	
		Cause	An attempt was made in a positioning motion to place the controller in the energy-saving status. This is only possible at rest. The drive does not take on the status and continues to travel.
		Measure	–

Error group 80		IRQ overflow	
No.	Code	Message	Reaction
80-0	F080h	Current regulator IRQ overflow	
		Cause	The process data could not be calculated in the set current/velocity/position interpolator cycle.
		Action	<ul style="list-style-type: none"> • Please contact Technical Support.
80-1	F081h	Speed regulator IRQ overflow	
		Cause	The process data could not be calculated in the set current/velocity/position interpolator cycle.
		Action	<ul style="list-style-type: none"> • Please contact Technical Support.
80-2	F082h	Overflow position controller IRQ	
		Cause	The process data could not be calculated in the set current/velocity/position interpolator cycle.
		Action	<ul style="list-style-type: none"> • Please contact Technical Support.
80-3	F083h	Interpolator IRQ overflow	
		Cause	The process data could not be calculated in the set current/velocity/position interpolator cycle.
		Action	<ul style="list-style-type: none"> • Please contact Technical Support.

Error group 81		IRQ overflow	
No.	Code	Message	Reaction
81-4	F084h	Low-Level IRQ overflow	
		Cause	The process data could not be calculated in the set current/velocity/position interpolator cycle.
		Action	<ul style="list-style-type: none"> • Please contact Technical Support.
81-5	F085h	MDC IRQ overflow	
		Cause	The process data could not be calculated in the set current/velocity/position interpolator cycle.
		Action	<ul style="list-style-type: none"> • Please contact Technical Support.

Error group 82		Internal sequencing control	
No.	Code	Message	Reaction
82-0	-	Internal sequencing control: Process cancelled	
		Cause	IRQ4 overflow (10 ms low-level IRQ).
		Action	<ul style="list-style-type: none"> Internal process control: Process was interrupted. Only for information - no measures required.
82-1	-	Multiple-started CO write access	
		Cause	Parameters in cyclical and acyclical operation are used concurrently.
		Action	<ul style="list-style-type: none"> Only one parameterisation interface can be used (USB or Ethernet).

Error group 83		Modules in Ext1/Ext2	
No.	Code	Message	Reaction
83-0	-	Invalid module	
		Cause	<ul style="list-style-type: none"> The plugged-in interface could not be detected. The loaded firmware is not known. A supported interface might be plugged into the wrong slot (e.g. SERCOS 2, EtherCAT).
		Action	<ul style="list-style-type: none"> Check firmware whether interface is supported. If it is: Check that the interface is in the right place and is plugged in correctly. Replace interface and/or firmware.
83-1	-	Module not supported	
		Cause	The plugged-in interface could be detected but is not supported by the loaded firmware.
		Action	<ul style="list-style-type: none"> Check firmware whether interface is supported. If necessary, replace the firmware.
83-2	-	Module: Hardware version not supported	
		Cause	The plugged-in interface could be detected and is basically also supported. In this case, however, the current hardware version is not supported (because it is too old).
		Action	<ul style="list-style-type: none"> The interface must be exchanged. If necessary, contact Technical Support.

Error group 84		Condition for controller enable	
No.	Code	Message	Reaction
84-0	-	Conditions for controller enable not fulfilled	
		Warn	
		Cause	<p>One or more conditions for controller enable are not fulfilled. These include:</p> <ul style="list-style-type: none"> – DIN4 (output stage enable) is off. – DIN5 (controller enable) is off. – Intermediate circuit not yet loaded. – Encoder is not yet ready for operation. – Angle encoder identification is still active. – Automatic current regulator identification is still active. – Encoder data is invalid. – Status change of the safety function not yet completed. – Firmware or DCO download via Ethernet (TFTP) active. – DCO download onto memory card still active. – Firmware download via Ethernet active.
		Action	<ul style="list-style-type: none"> • Check status of digital inputs. • Check encoder cables. • Wait for automatic identification. • Wait for completion of the firmware or DCO download.

Error group 90		Internal error	
No.	Code	Message	Reaction
90-0	5080h	External RAM not recognized	
		PSoff	
		Cause	External SRAM not detected / not sufficient. Hardware error (SRAM component or board is defective).
		Action	<ul style="list-style-type: none"> • Please contact Technical Support.
90-2	5080h	Error at FPGA boot-up	
		PSoff	
		Cause	The FPGA (hardware) cannot be booted. The FPGA is booted serially when the device is started, but in this case it could not be loaded with data or it reported a checksum error.
		Action	<ul style="list-style-type: none"> • Switch on the device again (24 V). If the error occurs again, the hardware is faulty.
90-3	5080h	Error at SD-ADU start	
		PSoff	
		Cause	SD-ADUs (hardware) cannot be started. One or more SD-ADUs are not supplying any serial data.
		Action	<ul style="list-style-type: none"> • Switch on the device again (24 V). If the error occurs again, the hardware is faulty.

Error group 90		Internal error	
No.	Code	Message	Reaction
90-4	5080h	SD-ADU synchronisation error after start	
		Cause	SD-ADU (hardware) not synchronous after starting. During operation, the SD-ADUs for the resolver signals continue running with strict synchronisation once they have been initially started synchronously. The SD-ADUs could not be started at the same time during the start phase.
		Action	<ul style="list-style-type: none"> Switch on the device again (24 V). If the error occurs again, the hardware is faulty.
90-5	5080h	SD-ADU not synchronous	
		Cause	SD-ADU (hardware) not synchronous after starting. During operation, the SD-ADUs for the resolver signals continue running with strict synchronisation once they have been initially started synchronously. This is checked continually during operation and an error is triggered if appropriate.
		Action	<ul style="list-style-type: none"> Possibly a massive EMC coupling. Switch on the device again (24 V). If the error occurs again, the hardware is faulty.
90-6	5080h	IRQ0 (current regulator): Trigger error	
		Cause	The output stage is not triggering the software IRQ, which then operates the current regulator. Very likely to be a hardware error on the board or in the processor.
		Action	<ul style="list-style-type: none"> Switch on the device again (24 V). If the error occurs again, the hardware is faulty.
90-9	5080h	Illegal firmware version	
		Cause	A development version compiled for the debugger was loaded regularly.
		Action	<ul style="list-style-type: none"> Check the firmware version, and update the firmware if necessary.

Error group 91		Initialisation error	
No.	Code	Message	Reaction
91-0	6000h	Processor error	
		Cause	Internal SRAM too small for the compiled firmware. Can only occur with beta versions.
		Action	<ul style="list-style-type: none"> Check the firmware version, and update the firmware if necessary.
91-1	-	Memory error when copying	
		Cause	Firmware parts were not copied correctly from the external FLASH into the internal RAM.
		Action	<ul style="list-style-type: none"> Switch on the device again (24 V). If the error occurs repeatedly, check the firmware version and update the firmware if necessary.

Error group 91		Initialisation error	
No.	Code	Message	Reaction
91-2	-	Error when reading the controller/power section coding	
		Cause	The ID-EEPROM in the controller or power section could either not be addressed at all or does not have consistent data.
		Action	<ul style="list-style-type: none"> Switch on the device again (24 V). If the error occurs repeatedly, the hardware is faulty. No repair possible.
91-3	-	Software initialisation error	
		Cause	One of the following components is missing or could not be initialised: <ol style="list-style-type: none"> Shared memory not available or defective. Driver library not available or defective.
		Action	<ul style="list-style-type: none"> Check firmware design, update if necessary.

Instructions on actions with the error messages 08-2 ... 08-7	
Action	Notes
<ul style="list-style-type: none"> Check whether encoder signals are faulty. 	<ul style="list-style-type: none"> Check the wiring, e.g. are one or more phases of the track signals interrupted or short-circuited? Check that installation complies with EMC recommendations (cable screening on both sides?). Only with incremental encoders: With TTL single-ended signals (HALL signals are always TTL single-ended signals): Check whether there might be an excessive voltage drop on the GND line; in this case = signal reference. Check whether there might be an excessive voltage drop on the GND line; in this case = signal reference. Check the level of supply voltage on the encoder. Sufficient? If not, change the cable diameter (connect unused lines in parallel) or use voltage feedback (SENSE+ and SENSE-).
<ul style="list-style-type: none"> Test with other encoders. 	<ul style="list-style-type: none"> If the error still occurs when the configuration is correct, test with a different (error-free) encoder (replace the connecting cable as well). If the error still occurs, there is a fault in the motor controller. Repair by the manufacturer required.

Tab. B.2 Instructions on error messages 08-2 ... 08-7

Index

A

Allocation of the plug connectors 27

C

CAN bus [X4] 74

Check operating status 57

Commissioning 55

Communication interfaces 72

Connect the PC 56

Connect the power supply 56

Connection: CAN bus [X4] 38

Connection: Encoder [X2B] 35

Connection: I/O communication [X1] 31

Connection: Incremental encoder input [X10] . 46

Connection: Incremental encoder output [X11] 47

Connection: Motor [X6] 39

Connection: Resolver [X2A] 34

Connection: Voltage supply [X9] 41

D

Device view 15

Documentation 6

E

Electrical installation 25

Emitted interference 51

Encoder connection [X2B] 74

Entire CMMP-AS system 13

ESD 26

ESD protection 54

G

General information on EMC 51

I

I/O interface [X1] 72

Installation clearance 24

Installation clearances 19

Instructions on safe and EMC-compliant
installation 51

Intended use 10

Intermediate circuit coupling 44

M

Manufacturing year 7

Mechanical installation 19

Mounting distance 24

O

Operation and display components 60

Overload current and short-circuit monitoring 58

P

PFC 43

Product identification 6

R

Rating plate 6

Resistance to interference 51

Resolver connection [X2A] 73

S

Service functions and diagnostic messages .. 58

T

Technical appendix 64

Type code 7

Copyright:
Festo AG & Co. KG
Postfach
73726 Esslingen
Germany

Phone:
+49 711 347-0

Fax:
+49 711 347-2144

e-mail:
service_international@festo.com

Internet:
www.festo.com

Original: de

Reproduction, distribution or sale of this document or communication of its contents to others without express authorization is prohibited. Offenders will be liable for damages. All rights reserved in the event that a patent, utility model or design patent is registered.