

ONLY AS EXAMPLE

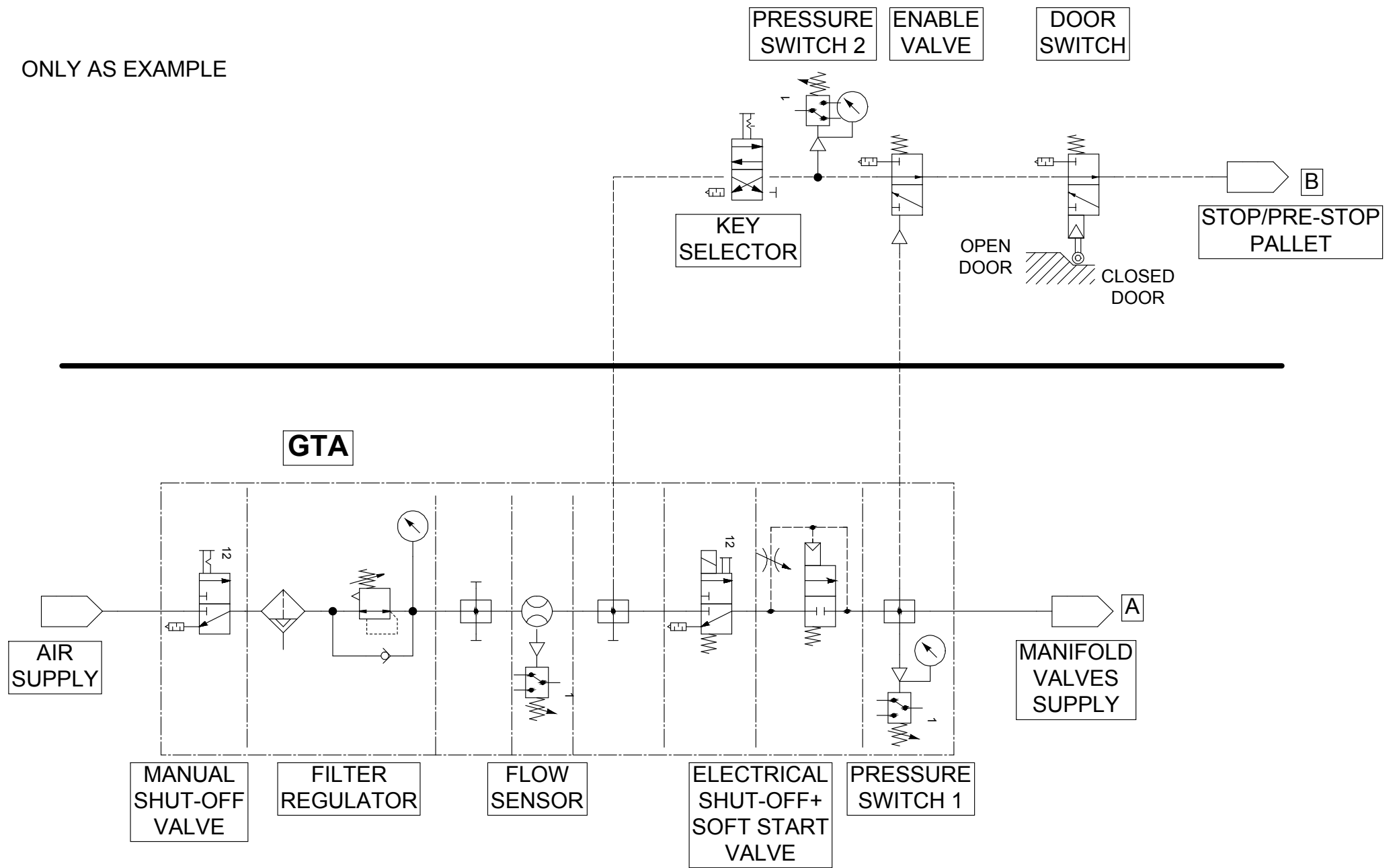

Pressure switch 2 must be supervised by PLC in order to:

- 1) Don't allow cycle start and manual movements if any pressure is detected.
- 2) Generate an end of cycle stop if any pressure is detected during automatic cycles.
- 3) Generate always an alarm on HMI, E.G. "stop exclusion activated by pneumatic key selector, deactivation necessary to continue".