

Solutions for palletising tasks

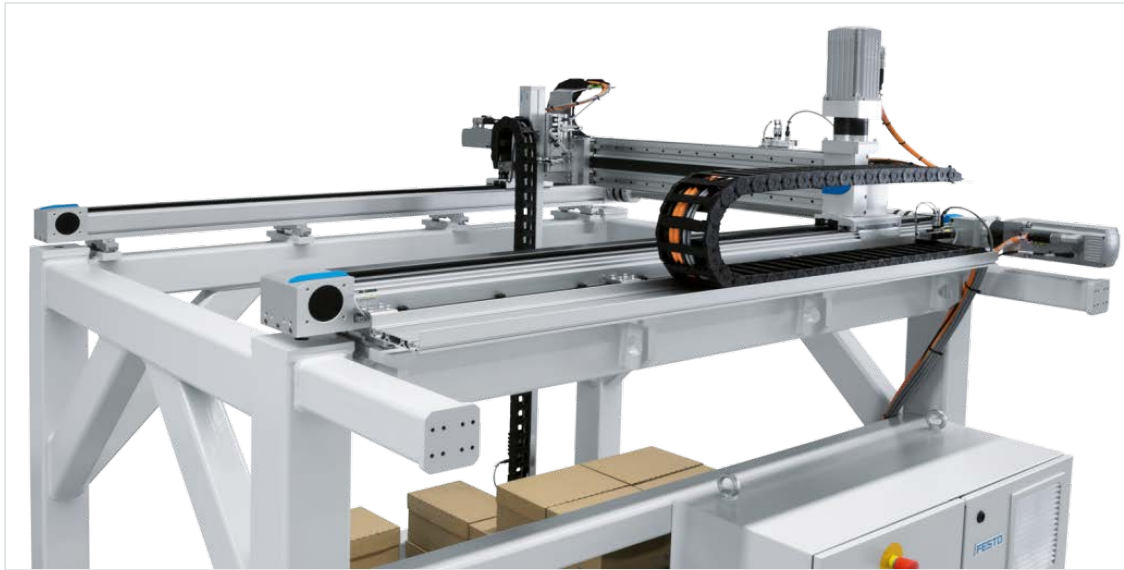

FESTO

Highlights

- Matched handling axes with grippers, a control cabinet and programming
- Created using electric and pneumatic standard components plus motors and controller as well as robotic control system
- Supplemented with safety functions as well as display and control units

Application

Solutions for palletising tasks, with ready-to-install handling systems

Requirements

Load pallets powerfully and effectively with high speed and dynamic acceleration, as well as with precise control for minimal vibrations

Solution

Customised, ideally suited for your application

- Users of our ready-to-install handling systems can practically eliminate the complex processes associated with development and construction
- Control cabinets are designed and built on a made-to-measure basis for a specific application – and by taking into account the needs of specific industries

Solutions for palletising tasks

Products and solutions



Toothed belt axis EGC-TB

Dynamic and fast with high rigidity. Specially developed profiles with an optimised cross section give maximum rigidity and load capacity. The motor can be attached on four sides, freely selectable.



Electric heavy-duty axis EGC-HD

The axis effectively absorbs lateral forces and torques. With a toothed belt or spindle drive with two parallel guides, it is perfect for cantilever systems.



Electric axis DGEA

Dynamic: shortest possible cycle times by separating motor and profile. As a Z-axis for planar surface gantries, variously combinable with semi-rotary drives and grippers.



Servo motors EMMS/E-AS with motor controller CMMP-AS

Servo motors with eight torque ranges, designed for dynamic positioning tasks.
Motor controller CMMP-AS: highly functional for dynamic movements, ideal for electronic control of cam discs.



Control package CMCA

A ready-to-install, application-specific control system. Enables the free 3D path control of highly dynamic kinematic systems.