

Terminal CPX

Control block CPX-CM-HPP

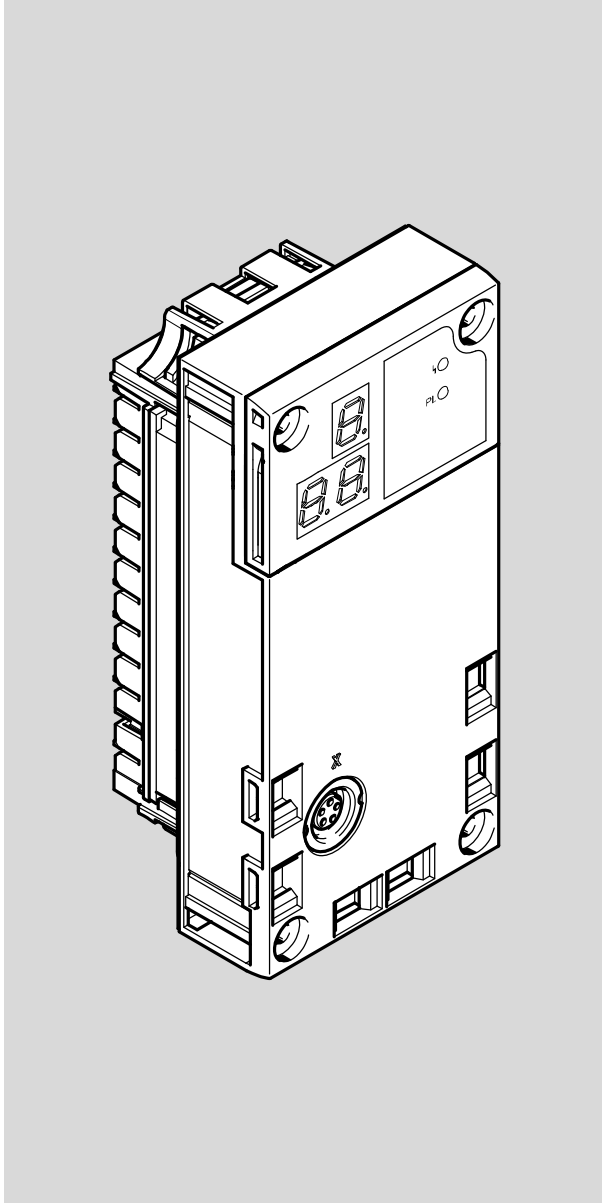

FESTO

Description

FHPP interface

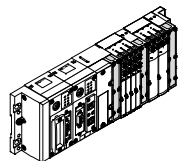

Description

568684

2017-06b

[8070655]

Contents and general instructions

Original instructions

Version 2017-06b

Designation CPX-CM-HPP-EN

Order no. 568684

© (Festo AG & Co. KG, 73734 Esslingen, Germany, 2017)

Internet: <http://www.festo.com>

E-Mail: service_international@festo.com

Reproduction, distribution or sale of this document or communication of its contents to others without express authorization is prohibited. Offenders will be held liable for damages. All rights are reserved, in particular the right to file patent, utility model or registered design applications.

PI PROFIBUS PROFINET®, DeviceNet® are registered trademarks of the respective trademark owners in certain countries.

Contents

Intended use	VII
Target group	VIII
Service	VIII
Important user information	IX
Safety instructions	XI
Notes regarding this description	XIII
Glossary	XV
1. System summary	1-1
1.1 The CPX-CM-HPP	1-3
1.1.1 Functions and key features	1-3
1.1.2 Tasks	1-3
1.2 Supported motor controllers	1-4
1.3 Control options	1-5
1.4 System configurations	1-6
1.4.1 Autonomous automation solution	1-6
1.4.2 Control of the CPX terminal through the higher-order controller ..	1-7
1.4.3 Autonomous automation solution with communication with a higher-order controller	1-8
1.5 Connection and display components	1-9
2. Fitting and installation	2-1
2.1 General instructions for installation	2-3
2.2 Dismantling and mounting	2-4
2.2.1 Dismounting	2-4
2.2.2 Mounting	2-5
2.3 Axis connection (CAN bus interface)	2-6
2.4 Connecting the CAN bus	2-7
2.4.1 CAN bus line	2-7
2.4.2 Terminating resistor	2-8

3.	Commissioning	3-1
3.1	General instructions on commissioning	3-3
3.2	Communication profile FHPP	3-4
3.2.1	Overview of FHPP data structure	3-5
3.3	Communication between CPX-CM-HPP and the motor controllers	3-9
3.4	Commissioning	3-10
3.5	Parameterisation of the connected motor controllers with FCT	3-12
3.5.1	Prerequisite for commissioning motor controllers with FCT	3-12
3.5.2	Commissioning motor controllers	3-12
3.5.3	Specific settings for motor controllers CMMD-AS, CMMS-AS and CMMS-ST	3-14
3.5.4	Specific settings for motor controller CMMP-AS	3-16
3.5.5	Specific settings for motor unit MTR-DCI-...-CO	3-17
3.5.6	Specific settings for motor controller SFC-DC-...-CO	3-18
3.5.7	Specific settings for motor controller SFC-LAC-...-CO	3-19
3.5.8	Specific settings for planar surface gantry EXCM with controller	3-19
3.5.9	Specific settings for integrated drive EMCA	3-20
3.5.10	Specific settings for controller CMXH	3-20
3.6	Configuration of the CPX-CM-HPP	3-21
3.6.1	Configuration parameters	3-21
3.6.2	Description Configuration parameters	3-22
3.6.3	Other parameters:	3-25
3.6.4	Configuration with the MMI	3-26
3.6.5	Configuration with CPX-FMT	3-28
3.7	Force	3-30
4.	Diagnostics and error treatment	4-1
4.1	Summary of diagnostics options	4-3
4.2	Errors and warnings	4-4
4.2.1	Behaviour in case of errors and warnings	4-4
4.2.2	Acknowledge errors	4-4
4.2.3	Error numbers	4-5
4.3	Diagnostics via display	4-11
4.4	Diagnostics via LEDs	4-13

Contents and general instructions

4.5	Diagnostics at the CPX terminal	4-15
4.5.1	Status bits in the system status of the CPX terminal	4-15
4.5.2	I/O diagnostic interface and diagnostic memory	4-16
4.5.3	Definition of diagnostics channels	4-19
A.	Technical appendix	A-1
A.1	Technical data	A-3
A.2	Accessories	A-4
A.3	Device-specific information on the CPX-MMI handheld	A-5
B.	Index	B-1

Intended use

The module CPX-CM-HPP documented in this description is intended exclusively for use in CPX terminals from Festo for installation in a machine or automated system.

The CPX-CM-HPP in combination with a controller allows the independent actuation of up to four drives via CAN bus.

The CPX terminal with the CPX-CM-HPP must only be used as follows:

- As intended in an industry segment.
- in its original state without unauthorised modifications. Only the conversions or modifications described in the documentation supplied with the product are permitted.
- in perfect technical condition.
- only in combination with approved components For an overview of supported motor controllers, refer to Tab. 1/4.

The limit values specified for pressures, temperatures, electrical data, torques etc. must be observed.

Observe the regulations of the trade associations, German Technical Control Board (TÜV), VDE stipulations or corresponding national laws and regulations.

Target group

This description is intended exclusively for technicians trained in control and automation technology who have experience in installation, commissioning, programming and diagnostics of positioning systems.

Service

Please contact your local Festo service if you have any technical problems.

Important user information

Danger categories

This description includes instructions on the possible dangers that can occur if the product is used incorrectly. These notes are marked with a signal word (Warning, Caution, etc), printed on a shaded background and marked additionally with a pictogram. A distinction is made between the following danger warnings:



Warning

... means that non-observance can result in serious personal injury or damage to property.



Caution

... means that injury to people and damage to property can occur if this warning is not observed.



Note

... means that damage to property can occur if this warning is not observed.

In addition, the following pictogram marks passages in the text that describe activities involving electrostatic sensitive devices:



Electrostatically sensitive devices: Incorrect handling can cause damage to devices.

Marking of special information

The following pictograms mark passages in the text that contain special information.

Pictograms



Information:
Recommendations, tips and references to other information sources.



Accessories:
Information about necessary or useful accessories for the Festo product.



Environment:
Information about environmentally friendly use of products from Festo.

Text designations

- Bullet points denote activities that can be carried out in any order.
- 1. Numerals label activities that must be carried out in the sequence specified.
- Arrowheads indicate general lists.

Square brackets mark menu entries.
Example: [Configuration].

Arrow brackets mark placeholders for designations/identifiers. Example: “Status of <Your connection>”.

Quotation marks designate names of windows, dialogues and buttons. Example: “Status of <Your connection>”.

Safety instructions



Protection against dangerous movements

Warning

High acceleration forces of the connected actuators. Uncontrolled movements can cause collisions which can lead to serious injury.

Dangerous movements due to incorrect control of connected actuators, for example caused by:

- untidy or faulty wiring/cabling
- errors in operating the components
- errors in the measured value and signal encoders
- defective or non-EMC-compliant components
- errors in the higher-order control system

Switching off the compressed air or load voltage is not a suitable locking mechanism. In the event of a malfunction, this could lead to unintentional movement of the drive.

- Before carrying out assembly, installation and maintenance work, place the system in a safe state (e.g. by placing the drive in a safe position and deactivating the controller).
Only carry out work in the machine area when the compressed air and power supply are switched off and locked.
- Make sure that no personnel enters the sphere of influence of the drives or other connected actuators.
- Only switch on the compressed air when the system has been installed and parameterised by technically qualified staff.

- Holding brakes controlled by the drive controller alone are not suitable to ensure personal protection!
Protect vertical axes additionally from falling or sinking after switching off the compressed air and load voltage, such as by:
 - mechanically locking the vertical axis,
 - external braking, safety catch or clamping devices or
 - sufficient weight compensation of the axis.
- If used in safety-relevant applications, additional measures are necessary, e.g. in Europe the standards listed under the EC Machinery Directive must be observed. Without additional measures in accordance with legally specified minimum requirements, the product is not suitable as a safety relevant component in control systems.

Protection against pressurised lines



Warning

Danger of injury due to incorrect handling of pressurised lines!

Accidental movements of the connected actuator technology and uncontrolled movements of loose tubing can cause injury to people or material damage.

- Do not disconnect, open or cap pressurised lines.
- The tubing must always be vented before removal (release compressed air).
- Use suitable protective equipment (e.g. safety goggles, safety shoes, etc.).

Notes regarding this description



Note

This description refers to the module CPX-CM-HPP from revision 01.

You will find the revision on the product label.

This description contains specific information regarding the mode of operation, mounting, installation and commissioning of the CPX-CM-HPP.

For additional information about the CPX-CM-HPP, refer to the following documentation.

Document	Table of contents
Brief description of the CPX-CM-HPP	Information on mounting and installation of the CPX-CM-HPP.



Tab. 0/1: Overview of additional documentation for the CPX-CM-HPP



All available documents for the product

→ www.festo.com/pk

For additional information about the CPX terminal, refer to the following documentation.

Type	Title	Description
Description Electronics	"System description" CPX-SYS-... 	Overview of structure, components and method of operation of CPX terminals; Installation and commissioning instructions as well as basic principles of parameterisation
	"CPX bus node" CPX-FB... 	Instructions on assembly, installation, commissioning and diagnostics of the relevant bus nodes

Tab. 0/2: Excerpt from the overview of additional documentation for the CPX terminal

Glossary

The following product-specific terms and abbreviations are used in this manual:

Term/abbreviation	Significance
Logic 0	Input or output provides 0 V (also LOW, FALSE or 0-signal).
Logic 1	Input or output provides 24 V (also HIGH, TRUE or 1-signal).
0xA0 A0 _h	Hexadecimal numbers are marked by a prefixed "0x" or by a lowered "h". Example: 0xA0 = A0 _h = 160 decimal.
A	Digital output
AB	Output byte
Axis	Motor controller, linear/rotative axis, motor and gear units
Axis connection	Interface of the CPX-CM-HPP for connection of the motor controller via CAN bus.
CPX-FEC	Front unit controller as CPX module. Controller which can be integrated into the CPX terminal.
CPX-CEC-...	CoDeSys controller as CPX module. Controller which can be integrated into the CPX terminal.
CPX module	Collective term for the various modules which can be integrated into a CPX terminal.
CPX terminal	Complete system consisting of CPX modules.
E	Digital input
I/Os	Digital inputs and outputs
FE	Functional earth
Bus node	Provides the connection to specific fieldbuses. Transmits control signals to the connected modules and monitors their functionality (as CPX module: CPX bus node).
FHPP	Festo Handling and Positioning Profile
Handheld CPX-MMI	Handheld terminal for commissioning and service purposes
Parameters	Parameters which must be set so that the system can be operated.

Term/abbreviation	Significance
Parameters	Parameters which must be set so that the system can be operated.
RSB	Record status byte
Controller	Control of the CPX terminal and the CPX-CM-HPP is carried out through: <ul style="list-style-type: none">– a higher-order controller:<ul style="list-style-type: none">a controller that is connected to the CPX terminal via fieldbus– CPX-FEC or: CPX-CEC-... an integrated controller in the CPX terminal

Tab. 0/3: Terms and abbreviations

System summary

Chapter 1

1. System summary

Contents

1.	System summary	1-1
1.1	The CPX-CM-HPP	1-3
	1.1.1 Functions and key features	1-3
	1.1.2 Tasks	1-3
1.2	Supported motor controllers	1-4
1.3	Control options	1-5
1.4	System configurations	1-6
	1.4.1 Autonomous automation solution	1-6
	1.4.2 Control of the CPX terminal through the higher-order controller ..	1-7
	1.4.3 Autonomous automation solution with communication with a higher-order controller	1-8
1.5	Connection and display components	1-9

1. System summary

1.1 The CPX-CM-HPP

The CPX-CM-HPP is an interface for electric positioning and handling axes in the Festo CPX system.

Programming of the CPX-CM-HPP is not required. The following options are available for configuration:

- MMI
- FMT
- EDS file
- GSD file
- Programming software of the CPX front unit controller

1.1.1 Functions and key features

The CPX-CM-HPP is designed for up to 4 axes. The axes are connected at the front via the CAN bus interface (M9, 5-pin). The motor controllers are configured with the Festo Configuration Tool FCT.

The motor controllers are actuated by a higher-order controller via CPX bus node or the integrated CPX-FEC or CPX-CEC-... controller in the CPX terminal. The CPX-CM-HPP merely forwards the I/O data. The Festo data profile FHPP is used for the communication.

1.1.2 Tasks

The CPX-CM-HPP takes over the following tasks:

- Transmission of control and status data between the controller and the connected motor controllers
- Malfunction management

1. System summary

1.2 Supported motor controllers

The CPX-CM-HPP supports the following motor controllers:

Motor controller	Comment
CMMS-AS	–
CMMS-ST	–
CMMP-AS	–
Motor unit MTR-DCI-...-CO	–
SFC-DC-...-CO	–
SFC-LAC-...-CO	–
CMMD-AS	–
Planar surface gantry EXCM with controller	–
Integrated drive EMCA-EC-...-CO	–
Controller CMXH	–

Tab. 1/4: Supported motor controllers
(as of March 2017)

1. System summary

1.3 Control options

The CPX-CM-HPP can be controlled in two ways:

- Control through higher-order controller, using a CPX bus node

or

- Control through front unit controller in the CPX terminal

The Festo data profile FHPP is used for communication with the controller (32 byte input and output data, 8 bytes per axis).



You can find detailed information on the FHPP in the applicable description documentation of the motor controllers.

The following software versions of the CPX modules are required to operate the CPX-CM-HPP:

CPX module	Required version ¹⁾	Comment
CPX-FB11 (DeviceNet)	Revision 22 and above	–
CPX-FB13 (PROFIBUS)	Revision 23 and above	–
CPX-FEC	Revision 16 and above	–
¹⁾ Software version (SW) see product label		

Tab. 1/5: Required software versions as of September 2014)



Note the following for use of the CPX-CM-HPP:

- Deactivate the diagnostic byte for use of two CPX-CM-HPP in one CPX terminal.
- Do not change the CAN bus setting Node ID: Default 1.

1. System summary

1.4 System configurations

1.4.1 Autonomous automation solution

1 CPX-Terminal with
CPX-FEC / CPX-CEC-...
and CPX-CM-HPP

2 CAN bus

3 CMMS

4 EMMS

5 SFC-DC

6 SLTE

7 MTR-DCI

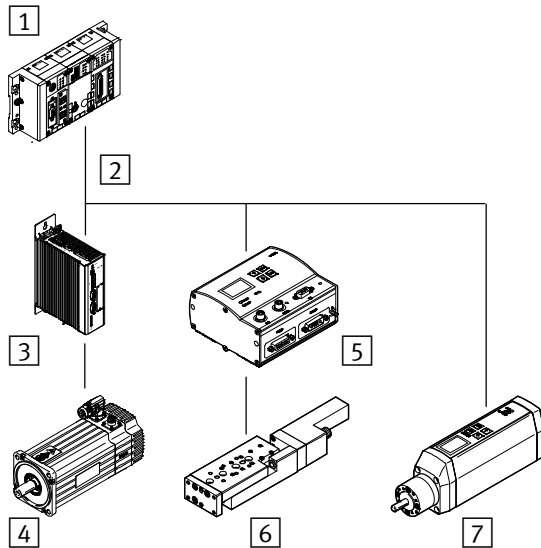

Fig. 1/1: Autonomous automation solution with CPX terminal, CPX-FEC/CPX-CEC-... and CPX-CM-HPP (example)

In this configuration, the sequence control of the CPX terminal is taken over by the CPX-FEC/CPX-CEC-... The Festo data profile FHPP is used for the communication.

1. System summary

1.4.2 Control of the CPX terminal through the higher-order controller

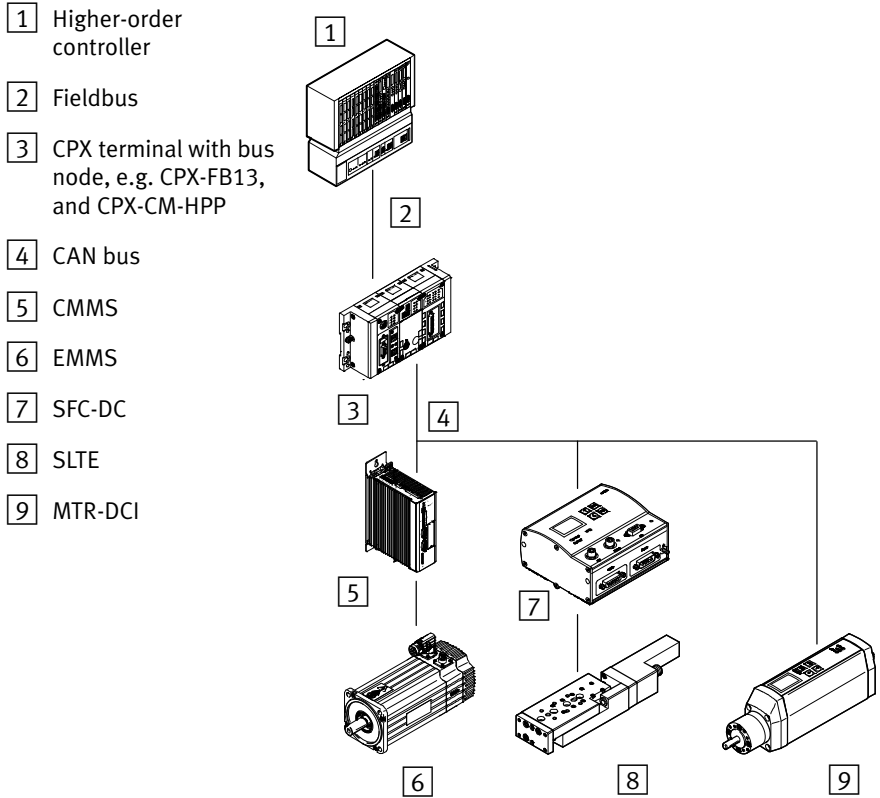

Fig. 1/2: Design of CPX terminal with higher-order controller (example)

In this configuration, the sequence control of the CPX terminal is taken over by a higher-order controller. The Festo data profile FHPP is used for the communication.

1. System summary

1.4.3 Autonomous automation solution with communication with a higher-order controller

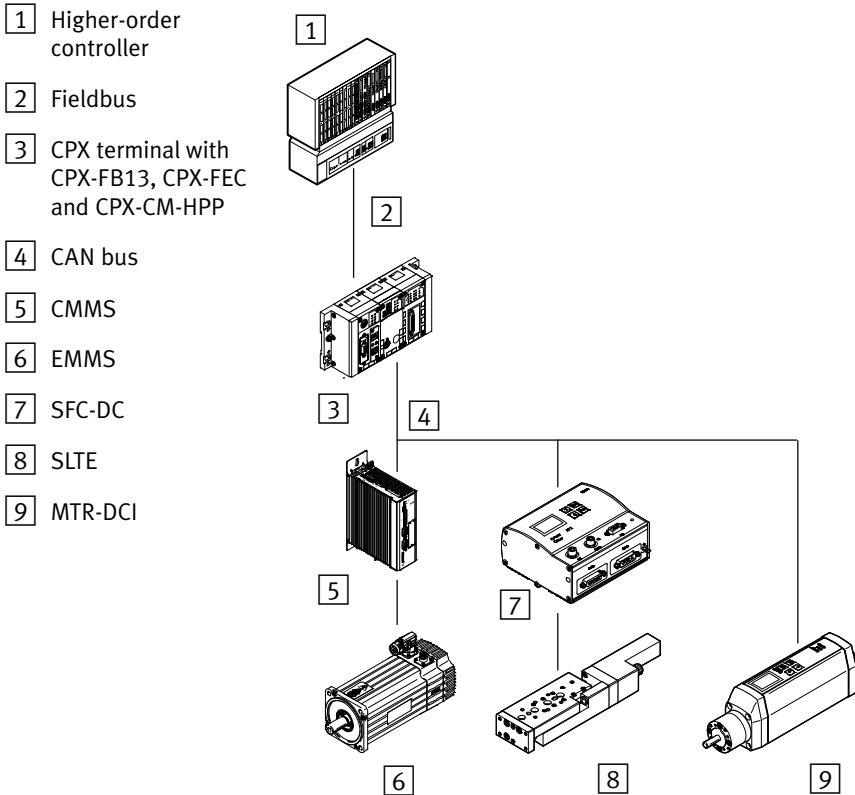

Fig. 1/3: Design of an autonomous automation solution with communication with a higher-order controller (example)

In this configuration, the sequence control of the CPX terminal is taken over by the CPX-FEC. The Festo data profile FHPP is used for the communication.

1. System summary

1.5 Connection and display components

The following connection and display components are found on the CPX-CM-HPP:

- 1 Status LEDs, see Section 4.4
- 2 X: Axis connection
- 3 Inscription labels (accessories)
- 4 3-digit display, see Section 4.3
- 5 Product label, see side

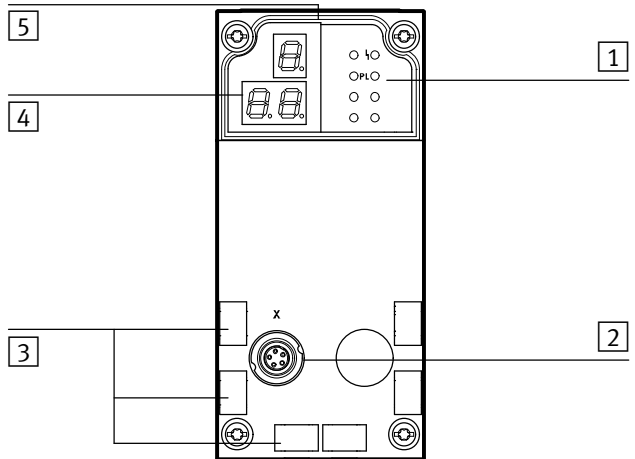

Fig. 1/4: Connection and display components on the CPX-CM-HPP

- 6 1st position (e.g. identifying letter for parameters or status type)
- 7 Point for separation
- 8 2nd and 3rd position (e.g. value, stage or status information)

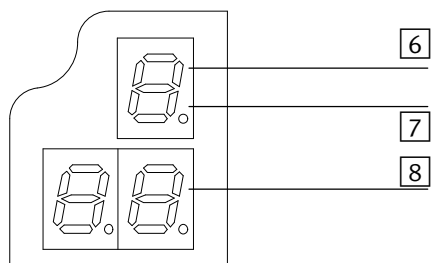

Fig. 1/5: Display/7 segment display

1. System summary

Fitting and installation

Chapter 2

2. Fitting and installation

Contents

2.	Fitting and installation	2-1
2.1	General instructions for installation	2-3
2.2	Dismantling and mounting	2-4
	2.2.1 Dismounting	2-4
	2.2.2 Mounting	2-5
2.3	Axis connection (CAN bus interface)	2-6
2.4	Connecting the CAN bus	2-7
	2.4.1 CAN bus line	2-7
	2.4.2 Terminating resistor	2-8

2. Fitting and installation

2.1 General instructions for installation



Warning

Before carrying out installation and maintenance work, switch off the following:

- if applicable, the compressed air supply
- operating voltage supply for the electronics/sensors
- load voltage supply for the outputs/valves

In this way, you can avoid:

- uncontrolled movements of loose tubing lines
- unintended movements of the connected actuators
- undefined switching statuses of the electronics



Warning

The CPX-CM-HPP contains electrostatically sensitive devices.

- Therefore, do not touch any components.
- Observe the handling specifications for electrostatically sensitive devices.

They will help you avoid damage to the electronics.

Information about mounting of the CPX terminal can be found in the CPX system description (CPX-SYS-...).

Information on mounting the components of the positioning system can be found in the related components documentation.

2. Fitting and installation

2.2 Dismantling and mounting

The CPX-CM-HPP is mounted in an interlinking block of the CPX terminal (see Fig. 2/1).

- 1 CPX-CM-HPP
- 2 Interlinking block
- 3 Contact rails
- 4 Screws,
tightening torque
0.9 ... 1.1 Nm

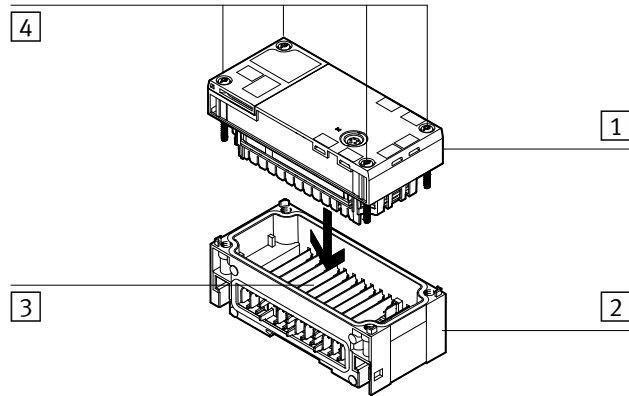

Fig. 2/1: Dismounting/mounting the CPX-CM-HPP

2.2.1 Dismounting

Dismount the CPX-CM-HPP as follows:

1. Loosen the 4 screws of the CPX-CM-HPP.
2. Pull the CPX-CM-HPP carefully and without tilting away from the contact rails of the interlinking block.

2. Fitting and installation

2.2.2 Mounting

Mount the CPX-CM-HPP as follows:

1. Place the CPX-CM-HPP in the interlinking block. Make sure that the slots with the terminals for electrical contact on the bottom of the CPX-CM-HPP are positioned directly above the contact rails.
2. Press the CPX-CM-HPP carefully and without tilting into the interlinking block up to the stop.
3. Join the screws so that the self-cutting threads can be used.
4. Tighten the screws by hand in diagonally opposite sequence. Tightening torque 0.9 ... 1.1 Nm.

2. Fitting and installation

2.3 Axis connection (CAN bus interface)

The motor controllers of the positioning system are connected via the CAN bus to the axis connection of the CPX-CM-HPP.

CAN bus parameters:

- Rate of transmission: 1 Mbit/s
- Data profile: FHPP
- Max. cable length: 30 m

The axis connection of the CPX-CM-HPP is designed as a 5-pin M9 socket contact.

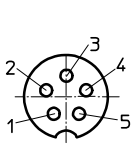
Bush M9	Pin	Signal	Core colour ¹⁾	Explanation
	1	n.c.		Not connected
	2	n.c.		Not connected
	3	CAN_GND	Green	CAN Ground
	4	CAN_H	White	CAN High
	5	CAN_L	Brown	CAN Low
	Housing			

1) with use of a connecting cable with open end, e.g. NEBC-M9W5-K-5-N-LE3

Tab. 2/6: Pin allocation of the CAN bus interface



The CPX-CM-HPP does not provide a power supply via the CAN bus interface to the CAN bus users.

2.4 Connecting the CAN bus

2.4.1 CAN bus line

**Note**

Faulty installation and high transmission rates may cause data transmission errors as a result of signal reflections and attenuations.

Transmission errors can be caused by:

- missing or incorrect terminating resistor
- incorrect screened connection
- branches
- long distances
- unsuitable cables

Use a Festo connecting cable with open end as a CAN bus line between CPX-CM-HPP and the first motor controller, e.g. NEBC-M9W5-K-5-N-LE3.

Use a twisted, screened 4-core cable as CAN bus line between the motor controllers. A CAN bus plug is available as an accessory to connect the motor controllers (→ www.festo.com/catalogue).

When using the Festo CAN bus plug, a cable diameter of 5 ... 8 or 7 ... 10 mm is permitted.

**Note**

If the CPX terminal is mounted onto the moving part of a machine, the CAN bus line on the moving part must be provided with strain relief. Also observe the corresponding regulations in EN 60204 Part 1.

2. Fitting and installation

2.4.2 Terminating resistor

A terminating resistor for the CAN bus is integrated at the axis connection.

A can bus terminating resistor for 120 ohms must only be installed at the other end of the CAN bus. Depending on the actuator, this terminating resistor is integrated in the actuator and activated with the DIL switch. If the actuator does not have an integrated terminating resistor, it must be connected manually between the signal CAN H (High) and CAN L (Low).

Commissioning

Chapter 3

Contents

3.	Commissioning	3-1
3.1	General instructions on commissioning	3-3
3.2	Communication profile FHPP	3-4
3.2.1	Overview of FHPP data structure	3-5
3.3	Communication between CPX-CM-HPP and the motor controllers	3-9
3.4	Commissioning	3-10
3.5	Parameterisation of the connected motor controllers with FCT	3-12
3.5.1	Prerequisite for commissioning motor controllers with FCT	3-12
3.5.2	Commissioning motor controllers	3-12
3.5.3	Specific settings for motor controllers CMMD-AS, CMMS-AS and CMMS-ST	3-14
3.5.4	Specific settings for motor controller CMMP-AS	3-16
3.5.5	Specific settings for motor unit MTR-DCI-....-CO	3-17
3.5.6	Specific settings for motor controller SFC-DC-....-CO	3-18
3.5.7	Specific settings for motor controller SFC-LAC-....-CO	3-19
3.5.8	Specific settings for planar surface gantry EXCM with controller	3-19
3.5.9	Specific settings for integrated drive EMCA	3-20
3.5.10	Specific settings for controller CMXH	3-20
3.6	Configuration of the CPX-CM-HPP	3-21
3.6.1	Configuration parameters	3-21
3.6.2	Description Configuration parameters	3-22
3.6.3	Other parameters:	3-25
3.6.4	Configuration with the MMI	3-26
3.6.5	Configuration with CPX-FMT	3-28
3.7	Force	3-30

3.1 General instructions on commissioning

**Warning**

Do not switch on the power supply and compressed air until the entire system has been installed completely and without errors.

**Warning**

Danger of collisions resulting in serious injuries due to unintended actuator movements.

- Be very careful when the axes are moving (e.g. when teaching positions, jogging and homing).
- Make sure that nobody enters the sphere of influence of the drives or other connected actuators.

Information about commissioning the CPX terminal can be found in the CPX system description (CPX-SYS-...).

Information on commissioning the components of the positioning system, motor controller, motors and axes can be found in the related components documentation.

3.2 Communication profile FHPP

Festo has developed an optimised data profile, the “Festo Handling and Positioning Profile (FHPP)” that is tailored to handling and positioning tasks.

The FHPP enables uniform control and programming for the various fieldbus systems and controllers from Festo.

In addition, it provides the user with uniform definitions of the

- operating modes,
- I/O data structure,
- parameter objects,
- sequence control.

An overview of the I/O data structure can be found in Section 3.2.1.

You can find detailed information on the FHPP in the applicable documentation of the motor controllers.



3. Commissioning

3.2.1 Overview of FHPP data structure

The following description of the telegram structure for communication with the CPX-CM-HPP indicates the byte allocation. Some items of the FHPP profile for the CPX-CM-HPP deviate from the standard FHPP.



You can find detailed information on the FHPP in the applicable documentation of the motor controllers.

Record selection operating mode								
	Byte 1	Byte 2	Byte 3	Byte 4	Byte 5	Byte 6	Byte 7	Byte 8
O-data X-axis	CCON	CPOS	Record no.	Reserved	Reserved			
I-data X-axis	SCON	SPOS	Record no.	RSB	Actual position			
	Byte 9	Byte 10	Byte 11	Byte 12	Byte 13	Byte 14	Byte 15	Byte 16
O-data Y-axis	CCON	CPOS	Record no.	Reserved	Reserved			
I-data Y-axis	SCON	SPOS	Record no.	RSB	Actual position			
	Byte 17	Byte 18	Byte 19	Byte 20	Byte 21	Byte 22	Byte 23	Byte 24
O-data Z-axis	CCON	CPOS	Record no.	Reserved	Reserved			
I-data Z-axis	SCON	SPOS	Record no.	RSB	Actual position			
	Byte 25	Byte 26	Byte 27	Byte 28	Byte 29	Byte 30	Byte 31	Byte 32
O-data U-axis	CCON	CPOS	Record no.	Reserved	Reserved			
I-data U-axis	SCON	SPOS	Record no.	RSB	Actual position			

3. Commissioning

Direct mode operating mode								
	Byte 1	Byte 2	Byte 3	Byte 4	Byte 5	Byte 6	Byte 7	Byte 8
O-data X-axis	CCON	CPOS	CDIR	Setpoint value 1 (speed)	Setpoint value 2 (position, force, torque,...)			
I-data X-axis	SCON	SPOS	SDIR	Actual value 1 (speed)	Actual value 2 (actual position, actual force, actual torque,...)			
	Byte 9	Byte 10	Byte 11	Byte 12	Byte 13	Byte 14	Byte 15	Byte 16
O-data Y-axis	CCON	CPOS	CDIR	Setpoint value 1 (speed)	Setpoint value 2 (position, force, torque,...)			
I-data Y-axis	SCON	SPOS	SDIR	Actual value 1 (speed)	Actual value 2 (actual position, actual force, actual torque,...)			
	Byte 17	Byte 18	Byte 19	Byte 20	Byte 21	Byte 22	Byte 23	Byte 24
O-data Z-axis	CCON	CPOS	CDIR	Setpoint value 1 (speed)	Setpoint value 2 (position, force, torque,...)			
I-data Z-axis	SCON	SPOS	SDIR	Actual value 1 (speed)	Actual value 2 (actual position, actual force, actual torque,...)			
	Byte 25	Byte 26	Byte 27	Byte 28	Byte 29	Byte 30	Byte 31	Byte 32
O-data U-axis	CCON	CPOS	CDIR	Setpoint value 1 (speed)	Setpoint value 2 (position, force, torque,...)			
I-data U-axis	SCON	SPOS	SDIR	Actual value 1 (speed)	Actual value 2 (actual position, actual force, actual torque,...)			

3. Commissioning

Control bytes



The functions of the individual bits may deviate from the following definition depending on the drive. For the valid definition, refer to the system description of the respective drives.

	B7	B6	B5	B4	B3	B2	B1	B0
	OPM2	OPM1	LOCK		RESET	BRAKE	Stop	ENABLE
CCON	Operating mode selection		MMI access blocked		Acknowledge malfunction	Release brake	Stop	Enable drive

	B7	B6	B5	B4	B3	B2	B1	B0
		CLEAR	TEACH	JOGN	JOGP	HOM	START	HALT
CPOS		Delete remaining path	Teach value	Jog negative	Jog positive	Start homing	Start positioning task	Stop

	B7	B6	B5	B4	B3	B2	B1	B0
	FUNC	FAST	XLIM	CTOG	CONT	COM2	COM1	ABS
CDIR	Execute function	Precise stop/quick stop	Stroke limit value deactivated	Toggle bit tracking mode	Tracking mode	Control mode (Position, force, torque, speed)		Absolute/Relative

3. Commissioning

Status bytes



The functions of the individual bits may deviate from the following definition depending on the drive. For the valid definition, refer to the system description of the respective drives.

	B7	B6	B5	B4	B3	B2	B1	B0
	OPM2	OPM1	LOCK	24VL	FAULT	WARN	OPEN	ENABLED
SCON	Operating mode feedback		Master control FCT/MMI	Load voltage is applied	Mal-function	Warning	Operation enabled	Drive enabled

	B7	B6	B5	B4	B3	B2	B1	B0
	REF	STILL	DEV	MOV	TEACH	MC	ACK	HALT
SPOS	Drive homed	Stand-still monitoring	Following error	Axis is moving	Acknowledge teaching	Motion complete	Acknowledge start	Stop

	B7	B6	B5	B4	B3	B2	B1	B0
	FUNC	FAST	XLIM	VLIM	CONT	COM2	COM1	ABS
SDIR	Function is executed	Precise stop/quick stop	Stroke limit reached	Speed limit reached	Tracking mode	Control mode feedback (Position, force, torque, speed)		Absolute/Relative

3. Commissioning

3.3 Communication between CPX-CM-HPP and the motor controllers

Communication between CPX-CM-HPP and the motor controllers takes place over the following interface:

Parameters	Settings
Interface	CANopen
Data profile	FHPP
Bit rate	1000 kBit/s or 1 MBit/s
CAN address	2...9

Tab. 3/1: Parameters of the interface

3.4 Commissioning

1. First, activate the drives as individual axes via the FCT with the relevant plug-in. Observe the required settings for the communication via CAN bus (see Chapter 3.5).
2. Configure the CPX-CM-HPP according to the drives (drive type, CAN address, data format, see Chapter 3.6). Adjust the start mode so that the system starts with the stored parameters (see CPX system description CPX-SYS-...).
3. Switch the CPX terminal off.
4. Connect the CPX-CM-HPP with the drives via a CAN bus cable (see www.festo.com/catalogue). Make sure that the bus terminal is activated at the last user on the drive side.
5. Switch the CPX terminal on.
The three-digit 7-segment display (see Fig. 1/5) shows the firmware design, e.g. Version 1.22:

1st position	2nd position	3rd position	Significance
1	2	2	Firmware Design 1.22

The CPX-CM-HPP starts the initialisation of the drives, e.g. with axis 1:

1st position	2nd position	3rd position	Significance
1	i	n	Initialisation of axis 1

After the initialisation has been completed correctly, all motor controllers will have status S0 and be ready for operation.

3. Commissioning

Error during initialisation

In the event of errors, the initialisation will stop at the faulty axis. The error number is displayed continuously, e.g.

1st position	2nd position	3rd position	Significance
4	E (= error)	1	Axis 4 shows Error 1



The initialisation will not continue until the error has been eliminated. For an overview of error numbers, see Chapter 4.2.3.

Error after initialisation

Errors that occur during operation are shown with an alternating display. First, the error type is shown (error or warning), followed by the error number. The duration of the display is approximately 0.5 s each. The example below shows the display for Error 44 on Axis 1:

1st position	2nd position	3rd position	Significance
1	E (= error) u (= Warning)		Axis 1 shows error type “Error” or “Warning”
1	4	4	Axis 1 shows Error 44



For an overview of error numbers, see Chapter 4.2.3.

3.5 Parameterisation of the connected motor controllers with FCT



The following information takes into account only a general approach for commissioning motor controllers and the specific settings of the motor controllers for use in positioning systems with CPX-CM-HPP. Information on other settings can be found in the documentation and online help for the respective motor controller.

3.5.1 Prerequisite for commissioning motor controllers with FCT

The following software packages and accessories are required for commissioning motor controllers:

- PC with FCT software and relevant plug-ins for the motor controllers
- Programming cable to connect the motor controllers to the PC, including special connections depending on the PC
- System descriptions of the relevant devices

3.5.2 Commissioning motor controllers



Note

Carry out the following instructions for each motor controller.

1. Connect the PC and the motor controller with a serial programming cable.
2. Start the FCT software and follow the instructions in the FCT and in the operating instructions of the respective motor controller.
3. Make sure that the limit switches (if installed) function properly.

3. Commissioning

4. Check the following parameters
 - Maximum travel
 - Maximum travel speed
 - Maximum acceleration or deceleration
 - Transmission ratio for position and speed
 - Software limit switch
 - Type of reference travel
5. Edit the travel record table if you want to operate the drive in record selection mode.
6. Save your settings in the controller (Download -> Save) and in the project (Save).

The following chapters describe the specific parameters for the relevant drives for the operation with CPX-CM-HPP.

3. Commissioning

3.5.3 Specific settings for motor controllers CMMD-AS, CMMS-AS and CMMS-ST

Menu/Tab	Parameters	Value
[Application data] [Operating mode selection]	Control interface	CANopen
[Controller][Fieldbus] [Interface parameter]	Data profile	FHPP
[Controller][Fieldbus] [Factor group]	Used	Activated
	Unit	mm for linear axes ° for rotative axes
	Exponent Position	10 ⁻³
	Exponent Speed	10 ⁻³
	Exponent Acceleration	10 ⁻³

Tab. 3/2: Specific settings for motor controllers CMMD-AS, CMMS-AS and CMMS-ST

Enter the following settings with the DIL switches of the motor controllers:

Parameters	Settings
Bus termination	On/Off
Bit rate	1000 kBit/s
CAN address	2...9

Tab. 3/3: Settings for motor controllers CMMD-AS, CMMS-AS and CMMS-ST

3. Commissioning



CAN address with CMMD-AS:

The setting for the CAN address of the first controller is entered in CMMD-AS. The CAN address of the first controller + 1 is automatically assigned to the second controller.

When the CMMD-AS is selected, only one controller of the CMMD-AS is assigned to an axis. When the second controller of the CMMD-AS must also be assigned to an axis, a CMMD must also be assigned to this axis.



For more information, refer to the documentation of the motor controllers.

3. Commissioning

3.5.4 Specific settings for motor controller CMMP-AS

Menu/Tab	Parameters	Value
[Application data] [Operating mode selection]	Control interface	CANopen
[Controller]	Enable logic Enabled with	DIN5 and Fieldbus
[Controller][Fieldbus] [Operating parameter]	Bit rate	1000 kBit/s
	Node number	CAN address of the axis, see Tab. 3/1
	Protocol	Festo FHPP
[Controller][Fieldbus] [Factor group]	Used	Activated
	Unit	mm for linear axes ° for rotative axes
	Exponent Position	10 ⁻³
	Exponent Speed	10 ⁻³
	Exponent Acceleration	10 ⁻³

Tab. 3/4: Specific settings for motor controller CMMP-AS

3. Commissioning

3.5.5 Specific settings for motor unit MTR-DCI-...-CO

Menu/Tab	Parameters	Value
[Configuration]	Motor type	MTR-DCI-...-CO
[Motor][Control interface] [Interface parameter]	CAN address	CAN address of the axis, see Tab. 3/1
	Bit rate	1 Mbit/s
	Data profile	FHPP
	Supply voltage	Internal With the “external” option, an external supply voltage must be connected at the CAN bus plug, see system description of motor unit MTR-DCI.

Tab. 3/5: Specific settings for motor unit MTR-DCI-...-CO

3. Commissioning

3.5.6 Specific settings for motor controller SFC-DC-...-CO

Menu/Tab	Parameters	Value
[Configuration]	Controller type	SFC-DC-...-CO
[Controller][Interface] [Interface parameter]	CAN address	CAN address of the axis, see Tab. 3/1
	Bit rate	1 Mbit/s
	Data profile	FHPP
	Supply voltage	Internal With the “external” option, an external supply voltage must be connected at the CAN bus plug, see system description of motor controller.

Tab. 3/6: Specific settings for motor controller SFC-DC-...-CO

3. Commissioning

3.5.7 Specific settings for motor controller SFC-LAC-...-CO

Menu/Tab	Parameters	Value
[Configuration]	Controller type	SFC-LAC-...-CO (CANopen)
[Controller][Interface]	CAN address	CAN address of the axis, see Tab. 3/1
	Bit rate	1 Mbit/s
	Data profile	FHPP
	Supply voltage	With the “external” option, an external supply voltage must be connected at the CAN bus plug, see system description of motor controller.

Tab. 3/7: Specific settings for motor controller SFC-LAC-...-CO

3.5.8 Specific settings for planar surface gantry EXCM with controller

Menu/Tab	Parameters	Value
[Configuration]	Controller type	EXCM
[Controller]	CAN address	CAN address of the axis, see Tab. 3/1
	Bit rate	1 Mbit/s
	Data profile	FHPP

Tab. 3/8: Specific settings for planar surface gantry EXCM with controller

3. Commissioning

3.5.9 Specific settings for integrated drive EMCA

Menu/Tab	Parameters	Value
[Configuration]	Controller type	EMCA
[Controller]	CAN address	CAN address of the axis, see Tab. 3/1
	Bit rate	1 Mbit/s
	Data profile	FHPP

Tab. 3/9: Specific settings for integrated drive EMCA

3.5.10 Specific settings for controller CMXH

Menu/Tab	Parameters	Value
[Configuration]	Controller type	CMXH
[Controller]	CAN address	CAN address of the axis, see Tab. 3/1
	Bit rate	1 Mbit/s
	Data profile	FHPP

Tab. 3/10: Specific settings for controller CMXH

3. Commissioning

3.6 Configuration of the CPX-CM-HPP

3.6.1 Configuration parameters

For each module, 64 bytes are reserved for module parameters that can be entered in the system table of the CPX terminal. Function number $4828+m*64+0...63$ (m = Module number in the CPX terminal).

Function number	Parameter entry	
$4828+m*64+6$	Axis 1	Axis type ¹⁾
$4828+m*64+7$		Node ID
$4828+m*64+8$		Format
$4828+m*64+9$	Axis 2	Axis type ¹⁾
$4828+m*64+10$		Node ID
$4828+m*64+11$		Format
$4828+m*64+12$	Axis 3	Axis type ¹⁾
$4828+m*64+13$		Node ID
$4828+m*64+14$		Format
$4828+m*64+15$	Axis 4	Axis type ¹⁾
$4828+m*64+16$		Node ID
$4828+m*64+17$		Format
1) No gaps are permitted in the list. Axis type = "No Axis" is the end of the list.		

Tab. 3/11: Function number 4828 – Configuration parameter

The configuration parameters are stored in the EEPROM of the CPX-CM-HPP. The Axis type and Node ID parameters are not effective until the next restart. The stored configuration

3. Commissioning

parameters are loaded as “Default Parameters” at the next start-up when the system parameter “System starts with default parameter” is selected in the CPX fieldbus node or the CPX-FEC.

3.6.2 Description Configuration parameters

Axis type

Value	Significance
0	No Axis (axis not present)
1	Motor controller CMMP-AS
2	Motor controller CMMS-AS
3	Motor controller CMMS-ST
4	Motor unit MTR-DCI-...-CO
5	Motor controller SFC-DC-...-CO
6	Motor controller SFC-LAC-...-CO
7	Planar surface gantry EXCM with controller
8	Motor controller CMMD-AS
9	Integrated drive EMCA
10	Controller CMXH

Tab. 3/12: Configuration parameters axis type

Node ID

CAN bus address of the motor controller

Value range: from 2 to 9

3. Commissioning

Format

Input and output format of the position value

Valid for:

- Actual position
- Setpoint position in direct operation



Warning

Danger of personal injury and material damage.
In the event of incorrect settings for format specifications, the setpoint positions of the actual positions may deviate.

- Check the format specifications carefully.

Value	Format	Significance
0	32 bit [Ink]	For motor controller CMMx-xx only: Original 32 bit Long Integer from motor controller. When the factor group for motor controller CMMx-xx is used, this 32 bit value represents the path (e.g. μm) depending on the resolution (e.g. 10^{-3}).
1	32 bit [μm]	For motor unit MTR-DCI and motor controller SFC-xx only: The 32 bit position value is converted to [μm] or [1/1000 °].

3. Commissioning

Value	Format	Significance			
2	VK/NK [mm]	When a 16 bit controller is used, e.g. CPX-FEC: With MTR-DCI and SFC-xx, the position value is first converted to [µm] or [1/1000 °] and then divided into value before comma (VK) and value after comma (NK).			
		Position value [µm] or [1/1000 °]	Position value [mm] or [°]	VK	NK
		245987	245.987	245	987
		1234034	1234.034	1234	34
		-200065	-200.065	-200	65
		-345	-0.345	0	-345

Tab. 3/13: Configuration parameter format



Two values are used when a controller with an address range > 65536 is used. A conversion to hexadecimal values is required, see example below:

245987 = 0x3C0E3

Byte 4,5 (FHPP): 0xC0E3

Byte 6,7 (FHPP): 0x0003

A conversion is not required when a higher-order fieldbus master and double-values are used.



When a Profibus controller is used, it must be ensured that the bytes are transmitted correctly. The bytes may need to be rotated.

3. Commissioning

3.6.3 Other parameters:

Function number	Parameters	Value	Comment
16+16*m+0	Module code	175	Entry in the CPX system table.
16+16*m+13	Version number	0 ... 255	Indicates the version of the module according to the product label.
784+m*4+0	Serial number		Byte 0: Contains the year and month of the series.
784+m*4+1			The bytes 1...3 contain one digit of the serial number per nibble (BCD encoded).
784+m*4+2			
784+m*4+3			

Tab. 3/14: Other parameters

3.6.4 Configuration with the MMI



The configuration with the MMI is not available for the following products:
CMMD-AS, CMXH, EMCA, EXCM.

Requirements

If you are using a system structure with a fieldbus slave as CPX master:

- Set the parameter “System start” (path: “CPX Terminal/System parameters/System start”) once to “Saved parameters”.

When the parameter “System start” is set to “Default-Parameter”, the default parameters will be loaded. The default parameters may deviate from the current system configuration.

Configuration

The configuration parameters of the CPX-CM-HPP are displayed and revised in the [Parameter] menu.



For a description of possible settings, see Chapter 3.6.1.

The configuration parameters of the CPX-CM-HPP are displayed and revised in the [Parameter] menu.

- When the parameterisation is complete, restart the CPX terminal to apply the revised parameters.

3. Commissioning

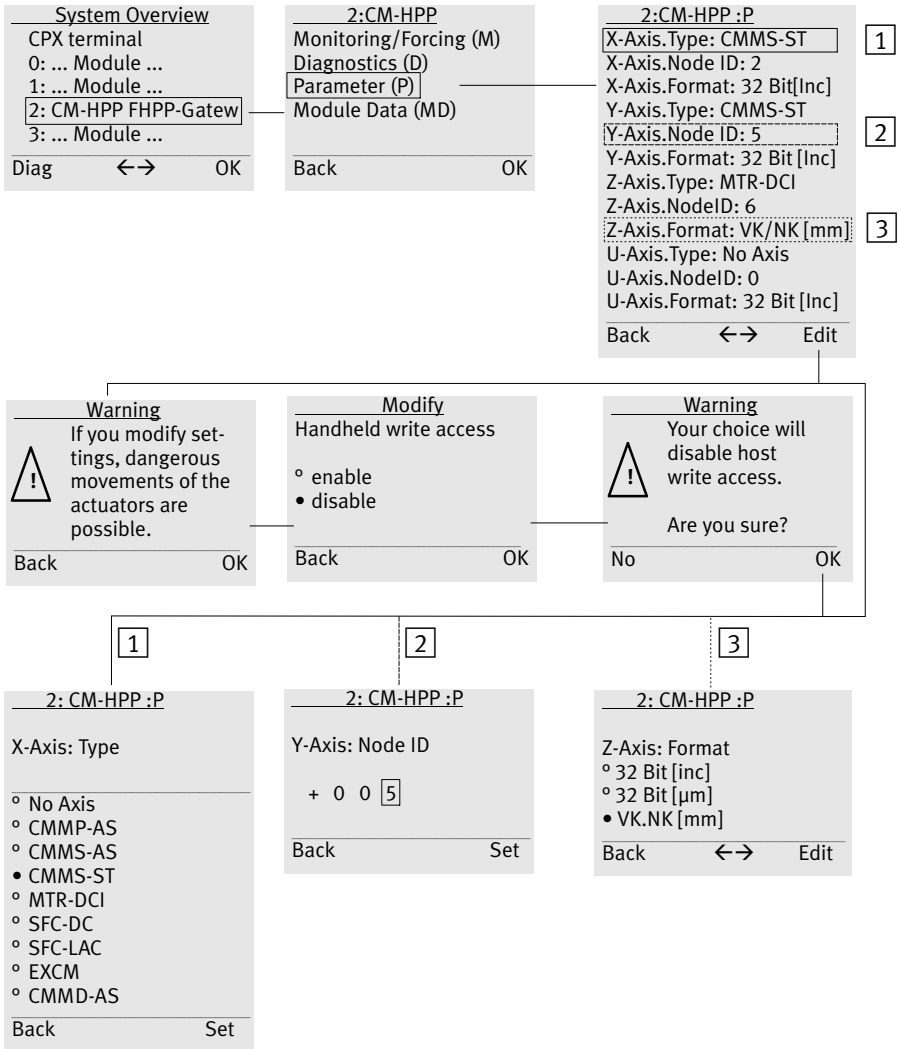

Fig. 3/2: Displaying and changing configuration parameters with the CPX-MMI.

3. Commissioning

3.6.5 Configuration with CPX-FMT

The following figures show the configuration of the CPX-CM-HPP with CPX-FMT.

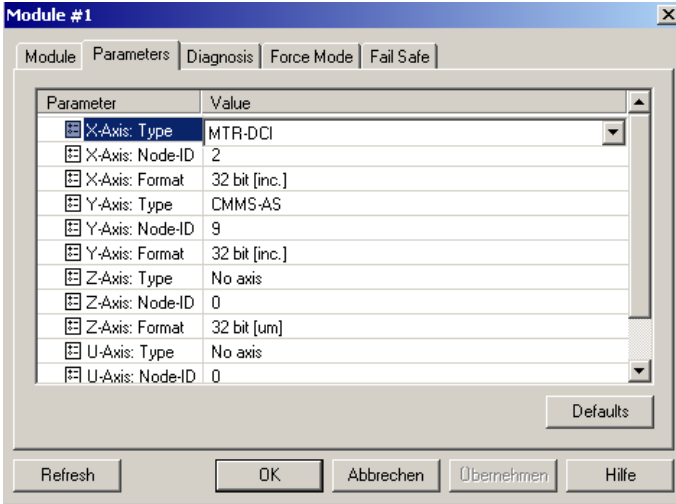

Fig. 3/3: Configuration with FMT: Selection axis.

3. Commissioning

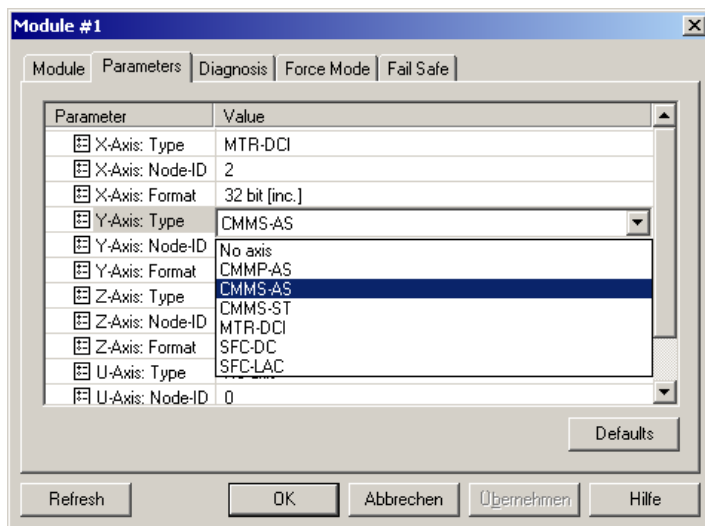

Fig. 3/4: Configuration with FMT: Selection axis type.

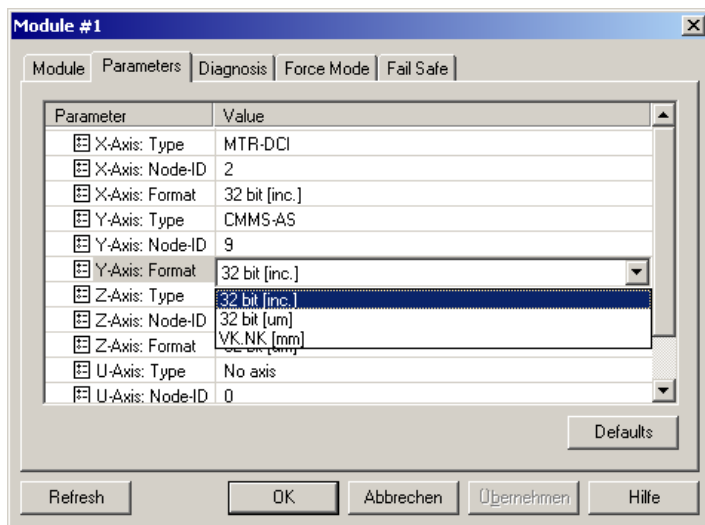

Fig. 3/5: Configuration with FMT: Selection format.

3.7 Force

Through forcing, you can force input and output signals. Actual input signals or status changes by program are ignored and replaced by the force values.



Warning

High acceleration forces of the connected actuators. Uncontrolled actuator movements can cause collisions which can lead to serious injury.

- Be very careful when forcing in order to avoid undesired movements of the actuators.
- Make sure that nobody enters the sphere of influence of the drives or other connected actuators.

The following options are available for forcing:

- Handheld type CPX-MMI
- Front unit controller
- Higher-order controller

You can define with the CPX terminal if forcing will be possible after the system start.



For additional information about forcing, refer to the CPX system description (CPX-SYS-...).

Diagnostics and error treatment

Chapter 4

Contents

4.	Diagnostics and error treatment	4-1
4.1	Summary of diagnostics options	4-3
4.2	Errors and warnings	4-4
4.2.1	Behaviour in case of errors and warnings	4-4
4.2.2	Acknowledge errors	4-4
4.2.3	Error numbers	4-5
4.3	Diagnostics via display	4-11
4.4	Diagnostics via LEDs	4-13
4.5	Diagnostics at the CPX terminal	4-15
4.5.1	Status bits in the system status of the CPX terminal	4-15
4.5.2	I/O diagnostic interface and diagnostic memory	4-16
4.5.3	Definition of diagnostics channels	4-19

4. Diagnostics and error treatment

4.1 Summary of diagnostics options

The CPX-CM-HPP supports various options for diagnostics and error handling in the CPX terminal. An overview is provided by Tab. 4/1.

Diagnostics option	Brief description	Advantages	Detailed description
Error messages	The CPX-CM-HPP reports specific malfunctions of the connected drives as error messages (error groups) to the CPX master.	Error messages can be evaluated via the CPX bus node or CPX-FEC/CPX-CEC or CPX-MMI.	See Chapter 4.2 and CPX system description
Diagnostics with the handheld type code CPX-MMI	Diagnostic information can be shown on the CPX-MMI in a user-friendly and menu-driven manner.	Rapid detection of errors "on-site".	See Chapter A.3 and description for handheld CPX-MMI.
Diagnostics with the display on the CPX-CM-HPP	The display on the CPX-CM-HPP shows status information and the error number of an actual malfunction (error or warning) of the individual axes in alternating order.	Rapid detection of errors "on-site".	See Chapter 4.3
LED display	The LED Error indicates error states directly.	Rapid detection of errors "on-site".	See Chapter 4.4
Status bits, I/O diagnostics interface and specific diagnostic functions	The errors recognised by the CPX-CM-HPP are reported in some cases to the CPX bus node or CPX-FEC/CPX-CEC with special additional information.	Fast access to error messages via the fieldbus, etc.	See CPX system description and descriptions of the respective CPX modules.

Tab. 4/1: Diagnostics options



Note

The available diagnostic information depends on the settings of the CPX bus node or the CPX-FEC/CPX-CEC.

4.2 Errors and warnings

The CPX-CM-HPP supports detailed error handling and evaluation. A list of errors is provided in Section 4.2.3.

4.2.1 Behaviour in case of errors and warnings

Depending on the parameterisation of the motor controller, a malfunction is reported to the CPX-CM-HPP either as an error message or as a warning.



Warning

When an error occurs, only the affected axis will stop. All other axes will continue their movement. Unintended actuator movements can thereby lead to collisions and result in serious injuries.

- Make sure that no personnel enters the sphere of influence of the drives or other connected actuators.
- If applicable, program the higher-order PLC so that the other axes will be blocked automatically in the event of an error.

If a warning occurs, the respective drive can continue to run depending on the selected setting. Some warnings will only be displayed for a certain period of time.

4.2.2 Acknowledge errors

The following options are available to delete the error:

- Acknowledge the error with CCON.Reset.
- Acknowledge the error with the CPX-MMI.
- Switch the operating voltage off and then on again.

4. Diagnostics and error treatment

4.2.3 Error numbers

Error messages are consolidated in error groups in the CPX terminal. For an overview of the error messages of the CPX-CM-HPP, see Tab. 4/2.

On the handheld type code CPX-MMI, the error groups of the individual drives are displayed in the Diagnostics menu. When an axis is selected, the error message for this axis is displayed in clear text.

Because it is partially possible to define if a status is a warning or an error in the drives, it is not possible to indicate the status type of the message in the CPX terminal with certainty. Therefore, the error numbers in the table below may not only be errors but also warnings.

The CPX-CM-HPP offers a 3-stage error diagnostics:

1. The CPX-CM-HPP reports the error group no. to the CPX master (error group no. 100 – 109).
2. The precise error below the error group is displayed on the 7-segment display of the CPX-CM-HPP and can be read out with the CPX-MMI.
3. Additional diagnostics options are then available via the displayed error messages directly at the motor controller.



For additional notes, refer to the descriptions of the respective motor controllers.



The list of possible error causes in the table below does not claim to be complete. If in doubt, contact your local Festo Service.

4. Diagnostics and error treatment

Error No.	Description and possible cause	Error handling
Configuration error (CPX error category 100)		
1	CAN communication cannot be established <ul style="list-style-type: none"> – Logic voltage of the actuator not switched on. – Cable defective. – Wrong communication settings (Profile: FHPP, Node ID, Baud rate). – No terminating resistors. 	<ul style="list-style-type: none"> • Switch on the logic voltage of the actuator • Replace cable • Correct settings • Install terminating resistors
2	Wrong axis type in the configuration	<ul style="list-style-type: none"> • Correct axis type
3	FHPP data profile not active	<ul style="list-style-type: none"> • Correct communication profile
Execution error (CPX error category 101)		
10	Axis is not referenced	<ul style="list-style-type: none"> • Carrying out homing
11	Error when homing is started <ul style="list-style-type: none"> – Internal drive error. 	<ul style="list-style-type: none"> • Contact Festo
12	Error during homing <ul style="list-style-type: none"> – Enable signal not set. 	<ul style="list-style-type: none"> • Check control signals for homing. • Check controller parameters
13	SW limit switch <ul style="list-style-type: none"> – Internal software limit of end position reached. 	<ul style="list-style-type: none"> • Check software end position settings
14	Neg. limit switch <ul style="list-style-type: none"> – Neg. limit switch actuated. 	<ul style="list-style-type: none"> • Check neg. limit switch
15	Pos. limit switch <ul style="list-style-type: none"> – Pos. limit switch actuated. 	<ul style="list-style-type: none"> • Check pos. limit switch
16	Positioning error <ul style="list-style-type: none"> – Lag limit reached – Controller parameters incorrect. 	<ul style="list-style-type: none"> • Check controller parameters • Correct controller parameters

4. Diagnostics and error treatment

Error No.	Description and possible cause	Error handling
Position record error (CPX error category 102)		
20	Unknown command – Invalid entry in the record table of the drive	<ul style="list-style-type: none"> • Correct entry
21	Impermissible record number – Selection of a record number that does not exist in the record table of the drive	<ul style="list-style-type: none"> • Select another record
22	Acceleration not permitted – Invalid values in the record table of the drive	<ul style="list-style-type: none"> • Correct values
23	Invalid jump destination – Jump to a record that does not exist in the record table of the drive	<ul style="list-style-type: none"> • Correct jump destination
24	No position data record – Selection of a record without content in the record table of the drive	<ul style="list-style-type: none"> • Create a position data record or select a different record
Controller error (CPX error category 103)		
30	Arithmetic error in FHPP factor group – Internal error of the motor controller	<ul style="list-style-type: none"> • Contact Festo
31	Following error monitoring – Following error due to excessive load – Incorrect settings of the drive parameters (speed, acceleration, delay)	<ul style="list-style-type: none"> • Check controller parameters • Correct settings
32	Invalid operating mode – Incorrect setting of the operating mode in the FHPP profile	<ul style="list-style-type: none"> • Correct setting
33	Standstill monitoring – Axis is not at standstill	<ul style="list-style-type: none"> • Check controller parameters
34	Fast Stop error – Axis could not brake within the specified period of time	<ul style="list-style-type: none"> • Check controller parameters

4. Diagnostics and error treatment

Error No.	Description and possible cause	Error handling
104 System error_A Software, Communication (CPX error category 104)		
40	CAN bus communication error during transmission – Internal drive error	<ul style="list-style-type: none"> • Contact Festo
41	Stack overflow – Internal drive error	<ul style="list-style-type: none"> • Contact Festo
42	Error during initialisation/HW error/FW error – Internal drive error	<ul style="list-style-type: none"> • Contact Festo
43	Error in current measurement – Internal drive error	<ul style="list-style-type: none"> • Contact Festo
44	Node guarding or heart beat – Internal drive error	<ul style="list-style-type: none"> • Contact Festo
45	RS232 communication error – Internal drive error	<ul style="list-style-type: none"> • Contact Festo
46	Internal conversion error – Internal drive error	<ul style="list-style-type: none"> • Contact Festo
47	IRQ overflow – Internal drive error	<ul style="list-style-type: none"> • Contact Festo
System error_B Hardware (CPX error category 105)		
50	Overvoltage in intermediate circuit – Internal drive error	<ul style="list-style-type: none"> • Contact Festo
51	Undervoltage in intermediate circuit – Internal drive error	<ul style="list-style-type: none"> • Contact Festo
52	Failure of internal voltage – Internal drive error	<ul style="list-style-type: none"> • Contact Festo
53	SD card error – Internal drive error	<ul style="list-style-type: none"> • Contact Festo
54	Missing HW component in the controller – Internal drive error	<ul style="list-style-type: none"> • Contact Festo

4. Diagnostics and error treatment

Error No.	Description and possible cause	Error handling
55	Checksum error – Internal drive error	<ul style="list-style-type: none"> • Contact Festo
56	Flash error – Internal drive error	<ul style="list-style-type: none"> • Contact Festo
Error in the controller (CPX error category 107)		
70	Undervoltage at the controller (LogicVolt) – No voltage at the motor controller	<ul style="list-style-type: none"> • Check the power supply
71	I ² t error (overheating in the controller) – Excessive load at the output of the controller	<ul style="list-style-type: none"> • Reduce load. Check controller parameters.
72	Undervoltage or overload current at digital I/O – Internal drive error	<ul style="list-style-type: none"> • Contact Festo
73	No calibration data – Hardware error at the motor controller – SD card defective	<ul style="list-style-type: none"> • Contact Festo
74	No user parameter record – Hardware error at the motor controller – SD card defective	<ul style="list-style-type: none"> • Contact Festo
75	Operating hour counter error – Hardware error at the motor controller – SD card defective	<ul style="list-style-type: none"> • Contact Festo
Error in the measuring system (CPX error category 108)		
80	Angle encoder error – Encoder or resolver defective – Angle encoder cable defective – Hardware error at the motor controller	<ul style="list-style-type: none"> • Check the cable and replace if necessary • Contact Festo
81	Old angle encoder parameter record – Internal drive error	<ul style="list-style-type: none"> • Contact Festo
82	Index Pulse Warning	<ul style="list-style-type: none"> • Contact Festo

4. Diagnostics and error treatment

Error No.	Description and possible cause	Error handling
Error in the motor or output stage (CPX error category 109)		
90	Motor stop – Internal drive error	• Contact Festo
91	Error in driver supply – Input bridge of the power supply defective – Intermediate circuit defective	• Contact Festo
92	Power section over-temperature – Internal drive error	• Contact Festo
93	Motor overtemperature – Temperature sensor in motor defective – Motor too hot	• Contact Festo
94	Short circuit at output stage – Internal drive error	• Contact Festo
95	Motor temperature 5° below maximum – Internal error in motor	• Contact Festo
96	I ² t error – Internal error in motor	• Contact Festo
99	General error cannot be assigned – Other errors	• Contact Festo

Tab. 4/2: CPX-CM-HPP error messages

4.3 Diagnostics via display

The three-digit 7-segment display shows the status of the individual axis consecutively. The error number or warning number is displayed for malfunctions, see Section 4.2.3, Page 4-5.

- 1 1st position
(e.g. identifying letter for parameters or status type)
- 2 Point for separation
- 3 2nd and 3rd position
(e.g. value, stage or status information)

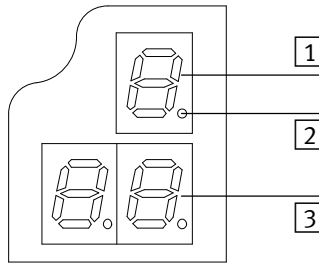

Fig. 4/6: Display/7 segment display

The following table describes the meaning of the individual positions of the 7-segment display.

1st position Axis no.	2nd position Mode/ Error no.	3rd position Status/ Error no.	Significance
1			Display of the state of the X-axis
2			Display of the state of the Y-axis
3			Display of the state of the Z-axis
4			Display of the state of the U-axis

4. Diagnostics and error treatment



1st position Axis no.	2nd position Mode/ Error no.	3rd position Status/ Error no.	Significance
	in Initialization		Display initialisation Connection set-up and initialisation of the axes consecutively. The initialisation for the next axis will not start until the initialisation for the current axis has been completed successfully.
S Set selection		0	Axis is switched on (Axis is READY)
		1	Controller enable (Axis is ENABLED)
		2	Axis is referenced (Axis is REFERENCED)
d Direct mode		0	Axis is switched on (Axis is READY)
		1	Controller enable (Axis is ENABLED)
		2	Axis is referenced (Axis is REFERENCED)
E Error			Error No.: 12 First, the display shows "E" and then "12".
12			
u Warning			Warning: 28 First, the display shows "u" and then "28".
28			

Tab. 4/3: Information on the three-digit 7-segment display

4. Diagnostics and error treatment



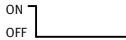

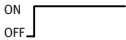

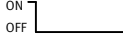

4.4 Diagnostics via LEDs

The following LEDs are available on the CPX-CM-HPP for diagnosing the CPX terminal.

PL (Power Load) – Load supply			
LED (yellow)	Sequence	Status	Error handling
 LED not illuminated		Power supply failure	<ul style="list-style-type: none">• Ensure the power supply.
 LED illuminated		Power supply OK	–

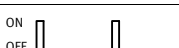
Tab. 4/4: PL LED

4. Diagnostics and error treatment

ERROR – Error			
LED (red)	Sequence	Status	Error handling
 LED not illuminated	ON  OFF	No error.	–
 LED flashing	ON  OFF	CPX system error, CPX error category 3	See CPX system description
	ON  OFF	CPX-CMXX error, CPX error category 2	
	ON  OFF	CPX system error, CPX error category 1	
	ON  OFF	Software update (flash programming) active	–
 LED illuminated	ON  OFF	1. CPX-CM-HPP is initialised 2. Communication or drive error. The states of the axis are shown in succession. Example 1: Only one axis is configured and reports an error. Result: The error LED is illuminated continuously Example 2: 4 axes are configured, but only one reports an error. Result: The error LED is always illuminated when the status of the faulty axis is displayed on the display.	–

Tab. 4/5: ERROR LED

4.5 Diagnostics at the CPX terminal

Malfunctions of the connected axes are reported as CPX error group to the CPX master (CPX bus node or CPX-FEC/CPX-CEC). One diagnostic channel is thereby available for each drive Tab. 4/9. The following sections include the special features of the representation for the CPX-specific diagnostics options.

- Status bits (see Section 4.5.1)
- Diagnostic memory with CPX error groups (I/O diagnostics interface, see Section 4.5.2)

4.5.1 Status bits in the system status of the CPX terminal

A CPX-CM-HPP error is always specified in the system status of the CPX terminal as follows:

Module type in which an error has occurred:

- Bit 0 - 2 = 0
- Bit 3 = 1:

Error in analogue/function or technology module

Error type

- Bit 4 - 6 = 0
- Bit 7 = 1: Other error

Further notes on the structure of the status bits can be found in the CPX system description (CPX-SYS-...).



4. Diagnostics and error treatment

4.5.2 I/O diagnostic interface and diagnostic memory

The CPX-CM-HPP reports the CPX error group to the CPX master (CPX bus node or CPX-FEC/CPX-CEC).

Diagnostics via the CPX error group can be carried out via the I/O diagnostics interface and the diagnostics memory of the CPX terminal.

Diagnostics memory data (I/O diagnostics interface)

The representation of diagnostic messages of the CPX-CM-HPP in the diagnostics memory of the CPX terminal occurs as shown in Tab. 4/6.

4. Diagnostics and error treatment

Diagnostic memory data (10 bytes per entry, max. 40 entries)				Function No ¹⁾															
Byte no.	Designation	Description	Value	3488 + n															
1 ... 5	Days [day] Hours [h] Minutes [m] Seconds [s] Milliseconds [ms]	Time specification of the reported error, measured from the point when the power supply is switched on (CPX standard).	0 ... 255 0 ... 23 0 ... 59 0 ... 59 0 ... 99 (128...227)	$n = 10 * d + 0$															
6	Module code	Module code of the CPX-CM-HPP: 175	0 ... 255	$n = 10 * d + 5$															
7	Module position [Pos]	Module number of the CPX module that signaled the error.	0 ... 47	$n = 10 * d + 6$															
8	Channel number	<table border="1"> <thead> <tr> <th>Bit</th> <th>Channel</th> <th>Description</th> </tr> </thead> <tbody> <tr> <td>00</td> <td>I1</td> <td>X-axis</td> </tr> <tr> <td>01</td> <td>I2</td> <td>Y-axis</td> </tr> <tr> <td>10</td> <td>I3</td> <td>Z-axis</td> </tr> <tr> <td>11</td> <td>I4</td> <td>U-axis</td> </tr> </tbody> </table>	Bit	Channel	Description	00	I1	X-axis	01	I2	Y-axis	10	I3	Z-axis	11	I4	U-axis	0 ... 255	$n = 10 * d + 7$
Bit	Channel	Description																	
00	I1	X-axis																	
01	I2	Y-axis																	
10	I3	Z-axis																	
11	I4	U-axis																	
9	Error number [FN]	CPX error group (see Section 4.2.3)	100 ... 109	$n = 10 * d + 8$															
10	Following channels	For CPX-CM-HPP always 0	0 ... 63	$n = 10 * d + 9$															
¹⁾ d (diagnostic event) [NB] = 0 ... 39 ; most current diagnostic event = 0																			

Tab. 4/6: Diagnostic memory data of the CPX-CM-HPP



Notes on diagnostics with the I/O diagnostics interface are found in the CPX system description.

4. Diagnostics and error treatment

Diagnostic data of the module (I/O diagnostic interface)

The specific representation of module diagnostic data (error messages) of the CPX-CM-HPP occurs as shown in Tab. 4/7 and Tab. 4/8.

Module diagnostic data: Location of the error																
Function no.	$2008 + m * 4 + 0;$ $m = \text{module number (0 ... 47)}$															
Description	Describes where the relevant error occurred.															
Bit	Bit 0 ... 7 Location where the error arose <table border="1"> <thead> <tr> <th>Bit</th> <th>Channel</th> <th>Description</th> </tr> </thead> <tbody> <tr> <td>00</td> <td>I1</td> <td>X-axis</td> </tr> <tr> <td>01</td> <td>I2</td> <td>Y-axis</td> </tr> <tr> <td>10</td> <td>I3</td> <td>Z-axis</td> </tr> <tr> <td>11</td> <td>I4</td> <td>U-axis</td> </tr> </tbody> </table>	Bit	Channel	Description	00	I1	X-axis	01	I2	Y-axis	10	I3	Z-axis	11	I4	U-axis
Bit	Channel	Description														
00	I1	X-axis														
01	I2	Y-axis														
10	I3	Z-axis														
11	I4	U-axis														

Tab. 4/7: Location where the error arose

Module diagnostic data: Module error number	
Function no.	$2008 + m * 4 + 1;$ $m = \text{module number (0 ... 47)}$
Description	CPX error category (see Chapter 4.2.3)
Bit	Bit 0 ... 7 Value range: 100..109

Tab. 4/8: Module error number

4. Diagnostics and error treatment

4.5.3 Definition of diagnostics channels

Four input channels are defined as diagnostics channels for the implementation of the axis-specific diagnostics. The individual diagnostics channels report errors for the respective drive.

The table below shows the definition of the diagnostics channels

	Channel number	Axis
Input channel	1	1
	2	2
	3	3
	4	4

Tab. 4/9: Definition of diagnostics channels

4. Diagnostics and error treatment

Technical appendix

Appendix A

Contents

A.	Technical appendix	A-1
A.1	Technical data	A-3
A.2	Accessories	A-4
A.3	Device-specific information on the CPX-MMI handheld	A-5

A.1 Technical data

Type	CPX-CM-HPP
General technical data of the CPX terminal	See CPX system description (CPX-SYS-...)
Total number of axes	Max 4 axes per CPX-CM-HPP
Device-specific diagnostics	<ul style="list-style-type: none"> – Channel and module-oriented diagnostics – Undervoltage/short circuit of modules – Diagnostic memory
Configuration support	CPX-MMI
LED display	PL: Power supply Error Error
Axis connection <ul style="list-style-type: none"> – Protocol – Baud rate – Fieldbus interface – Max. cable length 	CAN bus FHPP 1 Mbit/s Socket M9, 5-pin 30 m
CPX module code	175
Max. address capacity <ul style="list-style-type: none"> – Inputs – Outputs 	32 bytes 32 bytes
Degree of protection in accordance with IEC 60529, plug connector inserted	IP65
Nominal operating voltage	24 VDC
Operating voltage range	18 ... 30 VDC
Intrinsic current consumption <ul style="list-style-type: none"> – at nominal operating voltage 	Typ. 80 mA
Power failure buffering	10 ms
Product weight (without interlinking block)	Approx. 140 g
Dimensions W x L x H	50 mm x 107 mm x 55 mm

A.2 Accessories



Accessories for the CPX-CM-HPP can be found in our catalogue under www.festo.com/catalogue.

A.3 Device-specific information on the CPX-MMI handheld

Some information of the CPX-CM-HPP is specially depicted at the CPX MMI. This information is explained in the following by means of some examples.

System Overview		
CPX terminal		
0: FEC Controller		
1: CM-HPP FHPP-Gateway		
2: 8DI/8DO Multi I/O		
Diag	←→	OK

The CPX-CM-HPP is displayed as module “CM-HPP FHPP-Gateway” on the MMI. The complete name is displayed with the button “←→”.

The module related menu options and functions are explained below. Information about the system diagnosis that can be called under [Diag] is provided further down.

1: CM-HPP	
Monitoring/Forcing (M)	
Diagnostics (D)	
Parameters (P)	
Module Data (MD)	
Back	OK

The CPX-CM-HPP supports the following functions:

- Monitoring/Forcing (M)
- Diagnostics (D)
- Parameters (P)
- Module Data (MD)



Warning

Incorrect entries in the Force Mode, menu [Monitoring/Forcing (M)], can cause unintended movements and major property damage and personal injury!

A. Technical appendix

1: CM-HPP	
X-Axis: MTR-DCI	
Y-Axis: CMMS-AS	
Z-Axis: No Axis	
U-Axis: No Axis	
Back	OK

The current values of some of the inputs and outputs of the connected motor controllers are displayed in the [Monitoring/Forcing (M)] menu. The states of the inputs and outputs can be forced with the “Force Mode” function.

1: CM-HPP :M.X	
Process state	
I: Enabled	
I: Open	
I: Warn	
I: Fault	
I: 24VL	
I: Lock	
I: OPM1	
I: OPM2	
I: /Halt	
I: MC	
I: Ref	
O: Enable	
O: /Stop	
O: /Brake	
O: Reset	
O: Lock	
O: OPM1	
O: OPM 2	
O: /Halt	
Back	Force Mode

The following I/O data is displayed for each axis:

Entry in CPX MMI	FHPP-Bit
I: Enabled	SCON.B0
I: Open	SCON.B1
I: Warn	SCON.B2
I: Fault	SCON.B3
I: 24VL	SCON.B4
I: Lock	SCON.B5
I: OPM1	SCON.B6
I: OPM2	SCON.B7
O: Enable	CCON.B0
O: /Stop	CCON.B1
O: /Brake	CCON.B2
O: Reset	CCON.B3
O: Lock	CCON.B5
O: OPM1	CCON.B6
O: OPM2	CCON.B7
O: /Halt	CPOS.B0



Note

The status changes are not updated continuously. The allocation of the individual bits corresponds to the FHPP profile. Please observe the drive-specific allocation (e.g. see description CMM-FHPP-SW-DE)

Use the [Force Mode] function to switch to the [Force Mode] menu. The following warning will be displayed for the first call:

“Warning: If you modify settings, dangerous movements of the actuators are possible.”

How to activate the write authorization for the CPX-MMI handheld: Menu [Modify] function “Handheld write access” enable/disable.

- Select “Enable”

The following warning will be displayed:

“Warning: Your choice will disable host write access. Are you sure?”

- Confirm with “OK” to switch to the [Force Mode] menu.

<u>1: CM-HPP :M.Y</u>		
Drive Control (C)		
Exex Record (E)		
Jog / Ref / Teach (J)		
Back	Mode	OK

The following functions are available in the [Force Mode] menu:

- Drive Control (C)
- Exec Record (E)
- Jog / Ref / Teach (J)
- Mode

The following functions are available in the [Mode] menu:

- Clear force settings actual module/all modules
- Force Mode (Sys.par.) enable / disable

A. Technical appendix

<u>1: CM-HPP :M.Y.C</u>	
Sys: Force Mode enabled	
	State
Enable	
/Stop	
Reset	
/Halt	
Lock	
OPM1	
OPM2	
Back	Set

The following commands can be set in the [Drive Control (C)] menu:

Entry in CPX MMI	FHPP-Bit
Enable	CCON.B0
/Stop	CCON.B1
Reset	CCON.B3
/Halt	CPOS.B0
Lock	CCON.B5
OPM1	CCON.B6
OPM2	CCON.B7

<u>1: CM-HPP :M.Y.E</u>	
Sys: Force Mode enabled	
Record No.	0
	Set
Start	
/Stop	
/Halt	
Clear	
	State
MC	
Warn	
Fault	
Back	Set

A drive record can be selected and started in the [Exec Record (E)] menu. In addition, the following commands and status information are available:

Entry in CPX MMI	FHPP-Bit
Start	CPOS.B1
/Stop	CCON.B1
/Halt	CPOS.B0
Clear	CPOS.B6
MC	SPOS.B2
Warn	SCON.B2
Fault	SCON.B3

A. Technical appendix

1: CM-HPP :M.Y.J	
Sys: Force Mode enabled	
Set	
0	Home
0	Jog neg
0	Jog pos
0	/Teach
	State
MC	0
Ref	0
Warn	0
Fault	0
Teach Ack	0
Back	Set

You can now carry out the following functions in the [Jog / Ref / Teach (J)] menu. In addition, the following some status information is available:

Entry in CPX MMI	FHPP-Bit
Home	CPOS.B2
Jog neg	CPOS.B4
Jog pos	CPOS.B3
/Teach	CPOS.B5
MC	SPOS.B2
Ref	SPOS.B7
Warn	SCON.B2
Fault	SCON.B3
Teach Ack	SPOS.B3

1: CM-HPP :D	
Diagnostics	
X-Axis: 104-System error A	
Y-Axis: No error	
Z-Axis: No error	
U-Axis: No error	
Back	←→ Detail

The CPX error groups of the axes are displayed in the [Diagnostics (D)] menu.

1: CM-HPP :D.X	
Fault X-Axis: 104-44	
44- Node Guarding or Heart Beat	
Back	Res fault

The CPX error group, error number and the error text for the selected axis is displayed in the [Detail] menu.

For the description, refer to Section 4.2.3.

A. Technical appendix

<u>1: CM-HPP : MD</u>	
FHPP Gateway	
Type Code:	175
Revision:	1
Serial No.:	0x00000010
Back	

The following information for the CPX-CM-HPP is displayed in the [Module Data (MD)] menu (example).

- Module designation: FHPP Gateway
- Module type: 175
- Revision: 1
- Serial number: 0x00000010

<u>Diag overview</u>	
System Diagnostics	
Trace data	
1: CM-HPP FHPP-Gateway	
Back	ok

System diagnostics functions are available in the [Diag] menu.

<u>System diagnostics</u>	
Source of error	
O Valve	
O Output	
O Input	
• Analogue / function mo	
Type of error	
O Undervoltage	
O Short circuit / overload	
O Wire fracture	
• Other error	
Back	↔ First error

The CPX status bits are displayed in the [System diagnostics] menu.

<u>System Diagnostics</u>	
First faulty module	
1: CM-HPP FHPP-Gateway	
Fault number: 104	
System error A	
Back	

The following additional information about the current error is displayed in the [First Error] menu.

- Module position and designation
- Number of the CPX error group
- Designation of the CPX error group

A. Technical appendix

Trace data
NB-FN-Pos-Day-h-m-s-ms
√ 0 107 1 000:0:2:57:13

Back ←→ Detail

The error memory is displayed in the [Trace Data] menu.

- Number of the entry (NB)
- Number of the CPX error group (FN)
- Module position (Pos)
- Timestamp in format Days:Hours:Minutes:Seconds:Milliseconds (Day-h-m-s-ms) since the CPX terminal was switched on

Trace data number 0
In fault Ch 1
System error A
Module position 1
CM-HPP: FHPP-Gateway
Days: 0
Hours: 0
Minutes: 2
Seconds: 57
Milliseconds: 13

Back ←→

The following additional information about the current error is displayed in the [Detail] menu.

- Channel number
- Designation of the CPX error group
- Module position
- Module designation
- Timestamp in format Days:Hours:Minutes:Seconds:Milliseconds since activation



Note

For additional information about the CPX-MMI handheld, refer to the documentation CPX-MMI-1-...

A. Technical appendix

Index

Appendix B

B. Index

Contents

B.	Index	B-1
-----------	--------------------	------------

O

0-signal, XV

A

Abbreviations, product-specific, XV

Acknowledge errors, 4-4

Axis connection, XV

C

CAN bus

 Cable, 2-7

 Connect, 2-7

CAN bus interface, 2-6

Connection and display components, 1-9

D

Diagnostics

 CPX terminal, 4-15

 Diagnostics channels, 4-19

 Diagnostics memory, 4-16

 Display, 4-11

 I/O diagnostics interface, 4-16, 4-18

 LEDs, 4-13

 Status bits, 4-15

 Summary of diagnostics options, 4-3

Dismounting, 2-4

E

Errors and warnings

Acknowledge error, 4-4

Behaviour, 4-4

Error numbers, 4-5

Overview, 4-4

F

FHPP, 3-4

H

Handheld CPX-MMI, CPX-MMI, MMI, A-5

I

Installation, 2-3, 2-4, 3-3

Intended use, VII

L

Logic 1, XV

M

Module diagnostics data

Module error number, 4-18

Number of the first faulty channel, 4-18

N

Notes on the description, XIII

P

Pictograms, X

S

Safety instructions, XI

Service, VIII

Strain relief, 2-7

T

Target group, VIII

Technical data, A-3

Text designations, X

U

User information, IX

B. Index