

Integrated Drive

EMCA-EC-67-...-DIO

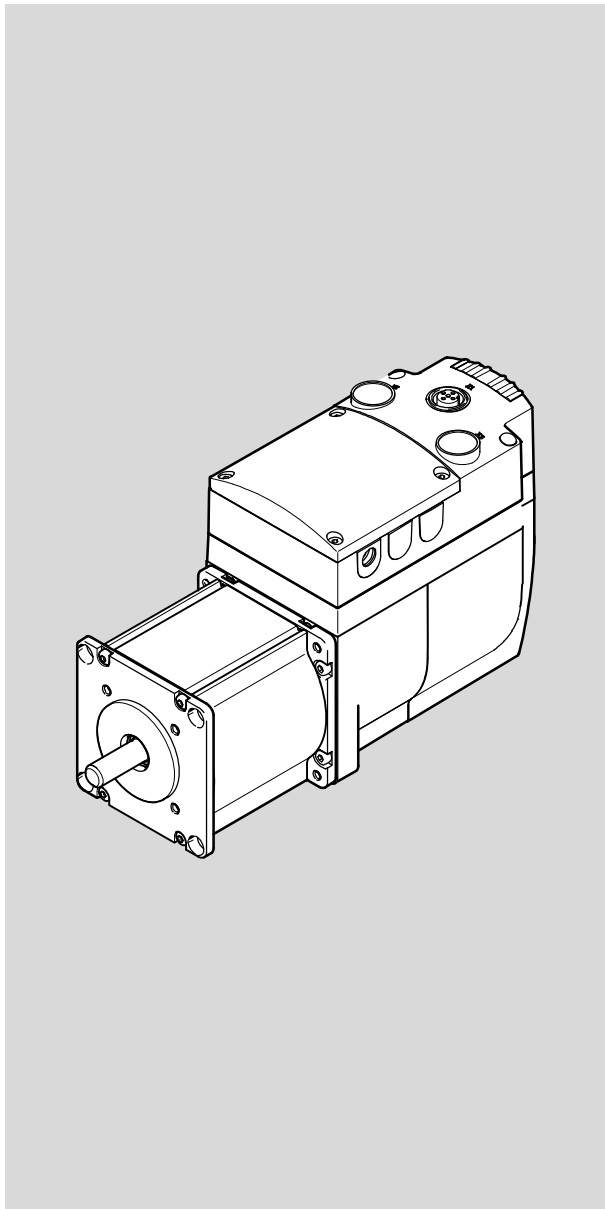

FESTO

Description

Integrated Drive
with I/O interface
and with Interface
for Modbus® TCP

Device and
functional
description

8072114
2017-05b
[8072116]

Original instructions
GDCE-EMCA-EC-DIO-EN

Adobe Reader®, CANopen®, CiA®, Firefox®, Internet Explorer®, JST®, MODBUS® and Tyco Electronics® are registered trademarks of the respective trademark owners in certain countries.

Identification of hazards and instructions on how to prevent them:



Danger

Immediate dangers which can lead to death or serious injuries



Warning

Hazards that can cause death or serious injuries



Caution

Hazards that can cause minor injuries

Other symbols:



Note

Material damage or loss of function



Recommendations, tips, references to other documentation



Essential or useful accessories



Information on environmentally sound usage

Text designations:

- Activities that may be carried out in any order
- 1. Activities that should be carried out in the order stated
- General lists
- ➔ Result of an action/References to more detailed information

Table of Contents – EMCA-EC-67-...-DIO

Instructions on this documentation	7
Target group	7
Product identification	7
Versions	8
Service	8
Manufacturing time period	8
Documentation on the product	10
1 Safety and requirements for product use	11
1.1 Safety	11
1.1.1 General safety instructions	11
1.1.2 Intended use	12
1.2 Requirements for product use	13
1.2.1 Transport and storage conditions	13
1.2.2 Technical prerequisites	13
1.2.3 Training of skilled personnel (requirements of the staff)	13
1.2.4 Product conformity and certifications	14
2 Product description	15
2.1 Product overview	15
2.1.1 General features of the product	16
2.1.2 Scope of delivery	17
2.1.3 System structure	18
2.2 Software for configuration and commissioning	19
2.2.1 FCT (Festo Configuration Tool)	19
2.2.2 Web server	19
2.3 Connections and display components	20
2.4 Drive functions	22
2.4.1 Dimension reference system	23
2.4.2 Homing	26
2.4.3 Jog mode	35
2.4.4 Teach-in mode	36
2.4.5 Positioning mode	37
2.4.6 Speed mode	40
2.4.7 Force/torque mode	44
2.4.8 Stop (halt), Quick-Stop	46
2.4.9 Holding brake (only EMCA-EC-...-B)	47
2.5 Operational principle for record selection	49
2.5.1 Record switching	49
2.5.2 Record sequencing	52

2.6	Monitoring of the drive behaviour	54
2.6.1	Dispatches	54
2.6.2	Comparators	58
2.6.3	Protective functions	61
2.6.4	Error management	62
2.6.5	Diagnostic memory	63
2.7	Interfaces	64
2.7.1	Ethernet interface [X1]	64
2.7.2	STO interface [X6]	65
2.7.3	Functions of the base inputs/outputs	66
2.7.4	Functions of the additional inputs/outputs	72
2.8	Control via the I/O interface	75
2.8.1	Create ready status	75
2.8.2	Set mode for the I/O interface	76
2.8.3	Enabling and disabling the controller	77
2.8.4	Acknowledge error	78
2.8.5	Carrying out homing	79
2.8.6	Jog, teach (mode 1)	80
2.8.7	Start record (mode 0)	81
2.8.8	Start, stop and continue record (mode 0)	82
2.8.9	Start and stop record, delete remaining path (mode 0)	83
2.8.10	Record switching	84
2.8.11	Release holding brake (only EMCA-EC-...-...-B)	85
3	Mounting	86
3.1	Dimensions	86
3.2	Performing mounting	87
4	Installation	89
4.1	Safety instructions	89
4.2	EMC-compliant wiring	90
4.3	Ethernet interface [X1]	91
4.4	Connection of the plug connectors [X4] ... [X10]	93
4.4.1	Power supply [X4]	96
4.4.2	Braking resistor [X5]	98
4.4.3	STO interface [X6]	99
4.4.4	Limit or reference switch [X7], [X8]	100
4.4.5	I/O interface [X9]	101
4.4.6	External battery [X10]	102
4.5	Requirements for ensuring IP degree of protection	103

5	Commissioning	104
5.1	Notes on commissioning	104
5.2	FCT (Festo Configuration Tool)	104
5.2.1	Installing FCT	104
5.2.2	Starting the FCT	105
5.2.3	Notes on commissioning with FCT	105
5.3	Network connection via Ethernet	107
5.3.1	Displaying or changing network configuration	108
5.3.2	Security in the network	109
5.4	Master control	111
5.5	Online connection with the web server	113
5.6	Commissioning steps	115
5.6.1	Configuration and parameterisation	115
5.6.2	Checking STO function	116
5.6.3	Check signal characteristics of the limit and reference switch	116
5.6.4	Providing required signals (digital I/Os)	117
5.6.5	Checking direction of rotation/travel direction	119
5.6.6	Carrying out homing	119
5.6.7	Testing positioning behaviour (test mode)	119
5.6.8	Optimising controller setting (optional)	119
5.6.9	Completing commissioning	120
5.7	Saving or loading parameter file	121
5.8	Notes for operation	122
5.8.1	Maximum writing cycles of the flash memory	122
6	Diagnostics and fault clearance	123
6.1	Access to the diagnostic memory	123
6.2	Diagnostics via LED	125
6.2.1	Behaviour during the switch-on phase	125
6.2.2	Behaviour in the operating phase	125
6.2.3	Identification sequence active	125
6.2.4	Behaviour with errors in the firmware update phase	126
6.3	Diagnostic messages, causes and remedies	127
6.3.1	Explanations of the diagnostic messages	127
6.3.2	Diagnostic messages with instructions for fault clearance	128
6.4	Problems with the Ethernet connection	142
6.5	Other problems and remedies	143

7	Maintenance, care, repair and replacement	144
7.1	Maintenance and care	144
7.2	Disassembly	145
7.3	Repair	146
7.4	Replacement and disposal	146
7.4.1	Disposal	146
A	Technical appendix	147
A.1	Technical data	147
A.1.1	General technical data	147
A.1.2	Product conformity and certifications	147
A.1.3	Mechanical data	148
A.1.4	Operating and environmental conditions	148
A.1.5	Data on the integrated motor	149
A.1.6	Data on the integrated rotary position encoder	150
A.1.7	Holding brake (only EMCA-EC-...-...-B)	150
A.1.8	Ethernet interface [X1]	150
A.1.9	Power supply [X4]	151
A.1.10	Braking resistor [X5]	151
A.1.11	STO interface [X6]	151
A.1.12	Reference or limit switch [X7], [X8]	152
A.1.13	I/O interface [X9]	153
A.1.14	Connection for external battery [X10] (only EMCA-EC-67-...-1TM)	154
A.1.15	Materials	154
B	Glossary	155
	Index	156

Instructions on this documentation

This documentation (GDCE-EMCA-EC-SY-...) describes the functions, commissioning and error messages of the integrated drive EMCA.

Target group



This documentation is intended exclusively for technicians trained in control and automation technology who have experience in installation, commissioning, parameterisation, programming and diagnostics of electrical drive systems.

Product identification

The product is available in various designs. The order code indicates the equipment features (see product label). This documentation describes the following product variants:

Characteristic	Order code	Type
Integrated Drive	EMCA-	Motor with controller, series A
Motor technology	EC-	EC motor
Flange size, motors	67-	67 mm
Size (with reference to the overall length of the motor)	M-	Medium
	S-	Short
Nominal operating voltage	1	24 V DC
Electrical connection	T	Terminal box
Measuring unit	E	Single-turn absolute encoder
	M	Multi-turn absolute measurement system
Brake	-	Without holding brake
	B-	with holding brake
Activation	DIO	Digital I/O interface
IP protection	-	Standard (IP54)
	S1	IP65

Tab. 1 Product label (e.g. EMCA-EC-67-M-1TEB-DIO)

Product label – example	Meaning	Example
 <p>EMCA-EC-67-S-1TE-DIO</p> <p>8061196 FN98 123456789...</p> <p>n_G : 3100 rpm M_N : 0.37 Nm U_N : 24 V DC I_N : 5.7 A IP54</p>  	<p>Order code</p> <p>Part number</p> <p>Serial number</p> <p>Product key</p> <p>Nominal rotary speed n_G [rpm]</p> <p>Nominal torque M_N [Nm]</p> <p>Nominal voltage U_N [V DC]</p> <p>Nominal current I_N [A]</p> <p>Degree of protection</p>	<p>EMCA-EC-67-S-1TE-DIO</p> <p>8061196</p> <p>FN98</p> <p>123456789...</p> <p>3100</p> <p>0.37</p> <p>24</p> <p>5.7</p> <p>IP54</p>

Tab. 2 Product label – example EMCA-EC-67-S-1TE-DIO



Information on the product key and the data matrix code → www.festo.com/pk.

Versions

For current versions of the firmware, FCT software and user documentation on the product → www.festo.com/sp.



This document refers to the following versions:

- EMCA with an order code specified in Tab. 1 with revision 1.0.0 or later
- Firmware version 1.2.0 or later
- FCT plug-in EMCA version 1.2.0 or later

The product key of the product can be entered as a search term in the Festo Support Portal to determine the revision of the device (→ www.festo.com/sp).



Note

Before using a newer firmware version, check whether a newer version of the FCT plug-in and a new user documentation are available for it (→ www.festo.com/sp).

Service

Consult the regional Festo contact if you have technical problems.

Manufacturing time period

In the product labelling, the first 2 characters of the serial number indicate the manufacturing date in encrypted form (→ Tab. 2). The letter specifies the year of manufacture and the character following it (number or letter) the month of manufacture.

Year of manufacture						
X = 2009	A = 2010	B = 2011	C = 2012	D = 2013	E = 2014	F = 2015
H = 2016	J = 2017	K = 2018	L = 2019	M = 2020	N = 2021	P = 2022
R = 2023	S = 2024	T = 2025	U = 2026	V = 2027	W = 2028	X = 2029

Tab. 3 Production year (20-year cycle)

Manufacturing month					
1	January	2	February	3	March
4	April	5	May	6	June
7	July	8	August	9	September
0	October	N	November	D	December

Tab. 4 Manufacturing month

Documentation on the product



For all available product documentation → www.festo.com/pk

The complete documentation for the product includes the following documents:

Designation	Table of contents
Brief documentation EMCA-...	Brief device and functional description for initial information
Manual GDCE-EMCA-EC-DIO-...	Device and functional description <ul style="list-style-type: none"> – Mounting – Installation (pin allocations) – Drive functions – Commissioning instructions – Error messages – Technical data
Manual GDCE-EMCA-EC-S1-...	Description of the safety function “Safely switched-off torque” (Safe torque off/STO)
Manual GDCE-EMCA-EC-C-HP-...	Description of the device profile FHPP (Festo Handling and Positioning Profile)
Help system for the FCT software (help for the EMCA plug-in)	Online help of the Festo Configuration Tool (FCT) for commissioning and parameterisation
Special documentation EMCA-EC_UL-...	Requirements for operating the product in the USA and Canada in accordance with certification by Underwriters Laboratories Inc. (UL)

Tab. 5 Documentation on the product



Further information about the product is available in the Festo Support Portal (→ www.festo.com/sp).

- Operating instructions for configurable electromechanical drives from Festo
- Certificates, declaration of conformity

Overview of accessories (catalogue) → www.festo.com/catalogue

1 Safety and requirements for product use

1.1 Safety

1.1.1 General safety instructions

- Always observe the safety information and warnings in the documentation of the product and of the other components used.
- Before mounting and installation work, switch off supply voltage and secure it against being switched on again. Only switch on the supply voltage again when mounting and installation work is complete.
- Never remove or insert a plug connector when the motor controller is powered.
- Observe the handling specifications for electrostatically sensitive devices.
- Only enable the controller if the drive has been professionally installed and fully parameterised.
- Do not carry out repairs on the device. If defective, replace the device.
- Besides the 4 screws on the housing cover, do not loosen any additional screws.



Caution

Rapidly rotating motor shaft with high torque.

Contact with the motor shaft can cause burn injuries and abrasions.

- Ensure that the rotating motor shaft and components attached to it cannot be touched.



Warning

Rapidly rotating motor shaft with high torque.

Clothing, jewellery and hair can be caught and wrapped around the shaft. People can be injured as a result.

- Make sure that clothing, jewellery or hair can **not** be caught by the rotating motor shaft.
- Ensure that clothing fits tightly.
- Hair nets must be worn with long hair.



Warning

Danger of burns from hot housing surfaces.

Contact with the motor housing can cause burn injuries. This can frighten people and cause them to act in an unpredictable manner. This can lead to other forms of secondary damage.



- Make sure that unintentional contact is not possible.
- Inform operating and maintenance staff about the possible hazards.
- Let the drive cool down to room temperature before maintenance work.



Note

Gas formation with fire risk.

If cleaning agents make contact with the hot surface of the motor, gases can form and ignite.

- Prior to cleaning work, let the drive cool down to room temperature.
- Pay attention to the instructions for use of the cleaning agent.

1.1.2 Intended use

The product is intended for driving and controlling electromechanical drives. The integrated electronics permit regulation of torque (current), rotational speed and position of the mounted drive. The product is intended for installation in a machine.

Depending on the order, the product contains a motor with holding brake (EMCA-EC-....-...B). The holding brake is intended to hold the motor position/drive position in standstill.

Use exclusively:

- In perfect technical condition
- In original status without unauthorised modifications; only the expansions described in the documentation supplied with the product are permitted
- Within the limits of the product defined by the technical data (➔ Appendix A.1)
- In an industrial environment

The product is intended for use in industrial environments. Outside of industrial environments, e.g. in commercial and mixed-residential areas, actions to suppress interference may have to be taken.

In the event of damage caused by unauthorised manipulation or other than intended use, the guarantee is invalidated and the manufacturer is not liable for damages.

The product supports the safety function “safe torque off” (Safe torque off/STO).



The STO safety function (Safe torque off) is described in detail in the document GDCE-EMCA-EC-S1-.... The safety function STO should only be used in the manner described in this document. Additional information ➔ Description of STO safety function, GDCE-EMCA-EC-S1-....

1.2 Requirements for product use

- Provide the complete product documentation to the following personnel:
 - the design engineer and the installer of the machine or system
 - the personnel responsible for commissioning
- Keep the documentation safe throughout the entire product lifecycle.
- Always comply with the specifications of the documentation. Also consider the documentation for the other components and modules (e.g. for the gearbox or axial kit).
- Take into consideration the legal regulations for the respective location as well as:
 - regulations and standards
 - regulations of the testing organisations and insurers
 - national specifications

For correct and safe use of the STO function:

- Observe the additional notes in the description for the GDCE-EMCA-EC-S1-....

1.2.1 Transport and storage conditions

- Protect the product during transport and storage from excessive stress factors. Excessive stress factors include:
 - mechanical stresses
 - out-of-range
 - moisture
 - aggressive atmospheres
- Store and transport the product in its original packaging. The original packaging offers sufficient protection from typical stresses.

1.2.2 Technical prerequisites

For correct and safe use of the product:

- Comply with the connection and ambient conditions of the product (→ Appendix A.1) and all connected components specified in the technical data. Compliance with the limit values and load limits permits operation of the product in compliance with the relevant safety regulations.
- Observe the notes and warnings in this documentation.

1.2.3 Training of skilled personnel (requirements of the staff)

The following steps must only be carried out by qualified specialists:

- Installation
- Installation
- Commissioning

The trained personnel must be familiar with the topics:

- electrical control technology
- applicable regulations for operating safety-engineering systems
- applicable regulations for accident prevention and operational safety
- documentation for the product

1.2.4 Product conformity and certifications

For standards and test values which the product must comply with → Technical data chapter (Appendix A.1).
Product-relevant EU directives → Declaration of conformity.



For certificates and the declaration of conformity for this product → www.festo.com/sp.

Certain configurations of the product have been certified by Underwriters Laboratories Inc. (UL) for the USA and Canada. These configurations are marked with the following symbol.



UL Recognized Component Mark for Canada and the United States

Only for connection to an NEC Class 2 supply.
Raccorder Uniquement a un circuit de Class 2.

Rules for observing the UL certification can be found in the separate UL special documentation. The technical data stated therein take priority. The technical data in this documentation can show values deviating from this.

Specified directives and standards

Issue statuses	
2006/42/EC	DIN EN 60068-2-6:2008-10
2014/30/EU	DIN EN 60068-2-27:2010-02

Tab. 1.1 Version statuses of the directives and standards specified in the document

2 Product description

2.1 Product overview

The integrated drive consists of the following components:

- brushless DC motor (EC motor) with
 - integrated encoder (single-turn absolute encoder or multi-turn absolute measurement system)
 - motor shaft for power transmission
 - motor flange for coupling and mounting
- device electronics with power, control and regulation electronics
- terminal box with interfaces for electrical installation

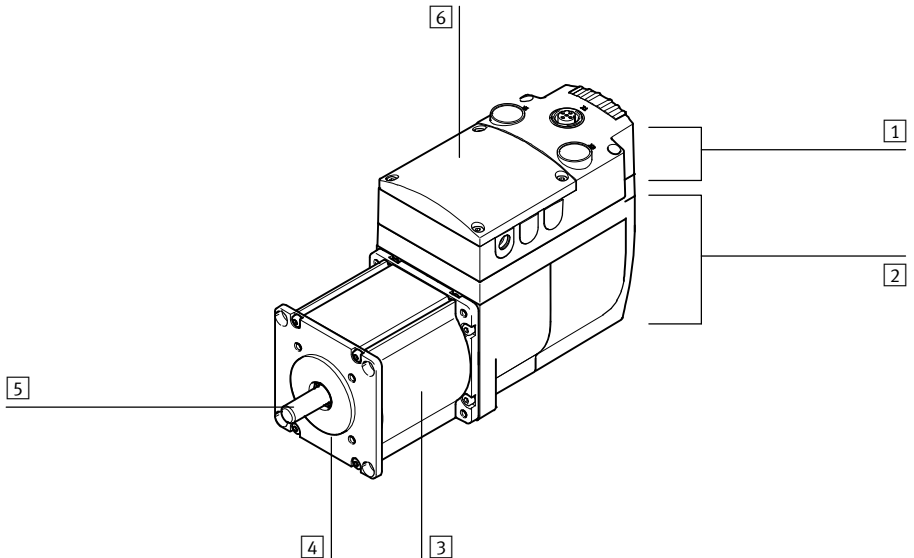

- | | |
|--|---|
| 1 Terminal box | 4 Motor flange |
| 2 Housing for device electronics | 5 Motor shaft |
| 3 EC motor | 6 Cover (covering for additional connections) |

Fig. 2.1 Components of the device (EMCA-EC-67-...-DIO)

The device has a compact design. The terminal box provides all of the necessary electrical connections. The Ethernet interface is freely accessible. All other electrical connections are underneath the cover of the terminal box (→ Fig. 2.3).

The device can be parameterised with FCT and commissioned via the Ethernet interface.

The device can be controlled via the I/O interface or via the Ethernet interface with Modbus[®] TCP and the FHPP device profile.

2.1.1 General features of the product

Feature	Description
EC motor	Brushless DC motor with: <ul style="list-style-type: none"> – integrated encoder (single-turn absolute encoder or multi-turn absolute measurement system) – Holding brake (optional)
Electronics	<ul style="list-style-type: none"> – Output stage for motor activation and control – Nominal voltage 24 V DC – Integrated brake chopper – braking resistor¹⁾ (accessories) must be connected externally – Integrated electronic controls, e.g. with: <ul style="list-style-type: none"> – Controller for current, speed and position control. – Ethernet interface – I/O interface – safety function STO (safe torque off) – diagnostic memory
Power supply	Shared load and logic power supply 24 V DC
Commissioning	Via the Ethernet interface with FCT
Diagnostics	LED indicator, web server, FCT software
Web servers	Software integrated into the device with the following functions: <ul style="list-style-type: none"> – display of status information and I/O data – readout of the diagnostics memory – uploading and downloading of a parameters file for easy device replacement Call via web browser (Internet Explorer or Firefox)

1) Available separately as an accessory (➔ www.festo.com/catalogue)

Tab. 2.1 Overview of product features EMCA

2.1.2 Scope of delivery

Number	Component
1	EMCA-... with cover, screws for cover mounting
1	<ul style="list-style-type: none"> - Brief description EMCA-67-...-DIO - For product variants with UL identification: special documentation EMCA-EC_UL-...
1	Sealing insert assortment
1	NEKM-C assortment of plugs (counter-plug for plug connector on the printed circuit board)

Tab. 2.2 EMCA scope of delivery



Available as accessories are, for example:

- Axial kits EAMM-A
- Battery box EADA-A-9(for EMCA-EC-67-1TM)
- Braking resistor CACR-LE2-6-W60
- Seal kit EADS-F (seals for axial kit)
- Motor flange EAMF-A
- Parallel kits EAMM-U
- Planetary gear unit EMGC
- Connecting cable for the Ethernet interface NEBC-D12G4-...
- Connecting cable for power supply NEBM-L4G2-...
- Connecting cable for the STO interface NEBM-L5G6-...
- Connecting cable for the I/O interface NEBM-L5G18-...



Current information on accessories → www.festo.com/catalogue.

2.1.3 System structure

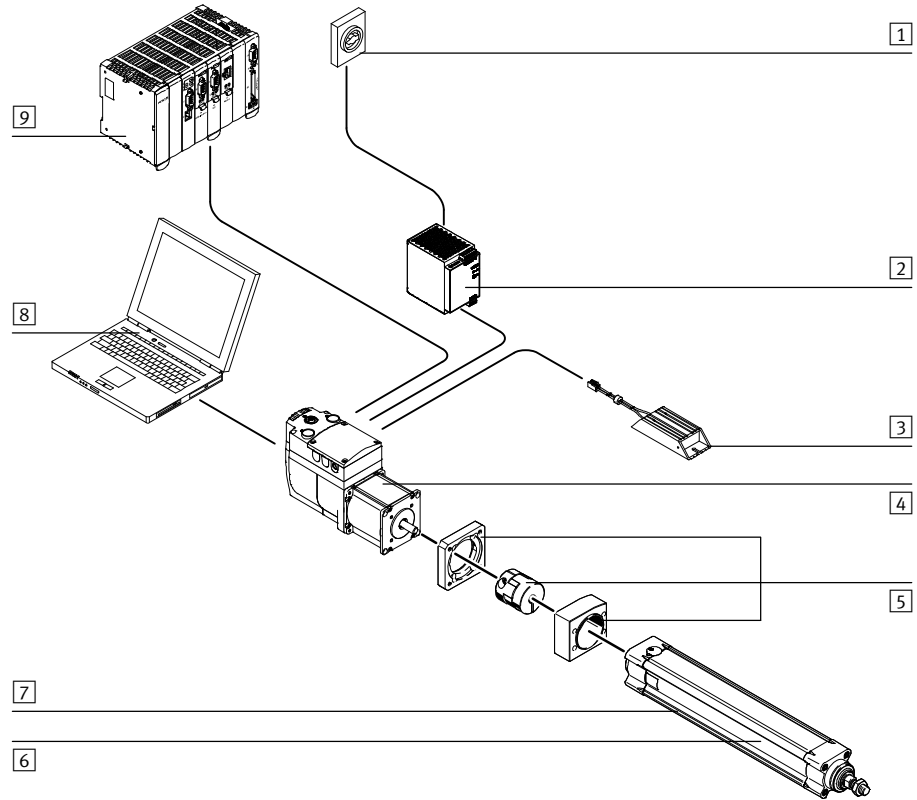

- | | |
|--|--|
| <ul style="list-style-type: none"> 1 Mains switch 2 PELV power supply unit 3 Braking resistor – example 4 EMCA 5 Coupling/axial kit – example | <ul style="list-style-type: none"> 6 Electromechanical drive – example
(here electric cylinder ESBF) 7 Reference switch/limit switch – example
(here without) 8 PC with Festo Configuration Tool (FCT) 9 Higher-order controller (PLC/IPC) |
|--|--|

Fig. 2.2 System structure (example)

2.2 Software for configuration and commissioning

2.2.1 FCT (Festo Configuration Tool)

The Festo Configuration Tool (FCT) is the Windows-based software platform for configuration, parameterisation and commissioning of different components and devices from Festo. FCT also allows configuration and commissioning of the integrated drive EMCA.

The FCT consists of the following components:

- a framework as program start and entry point with uniform project and data management for all supported types of equipment
- one plug-in for the special requirements of each device type (e.g. EMCA) with the necessary descriptions and dialogues

The plug-ins are managed and started from the framework. The EMCA plug-in supports performance of all the steps necessary for configuration, parameterisation and commissioning of the product. Parameterisation of the product can be executed offline (without connection to the EMCA) on a PC. This enables preparation for the actual commissioning, for example, in the planning office when a system is being planned.

The allows the following functions, for example:

- administration of the following data/files via the Ethernet interfaces (online):
 - device data (parameterisation)
 - firmware file (Firmware Download)
- manual operation (e.g. jogging, teaching)
- diagnostics
- recording of measurement data
- automatic calculation of the controller data for selected motor-gear unit-axis combinations from Festo
- manual precision adjustment of the controller data



For further information on commissioning with FCT → Chapter 5. Detailed information about FCT → Help system for the software.

2.2.2 Web server

A web server is integrated into the device. The web server provides read access to a dynamic English-language website for the device. The website of the web server allows the following functions:

- display of the status information of the device (e.g. current position, target position)
- display of the signal statuses of digital I/Os
- readout and display of the diagnostic memory
- uploading of a parameter file - e.g. to save current settings on the PC
- downloading of a parameter file - e.g. to restore settings
- activation of LED flashing to identify the device optically

The DHCP server (DHCP stands for Dynamic Host Configuration Protocol) of the device is activated in the factory setting, and the device has the following IP address: 192.168.178.1.

2.3 Connections and display components

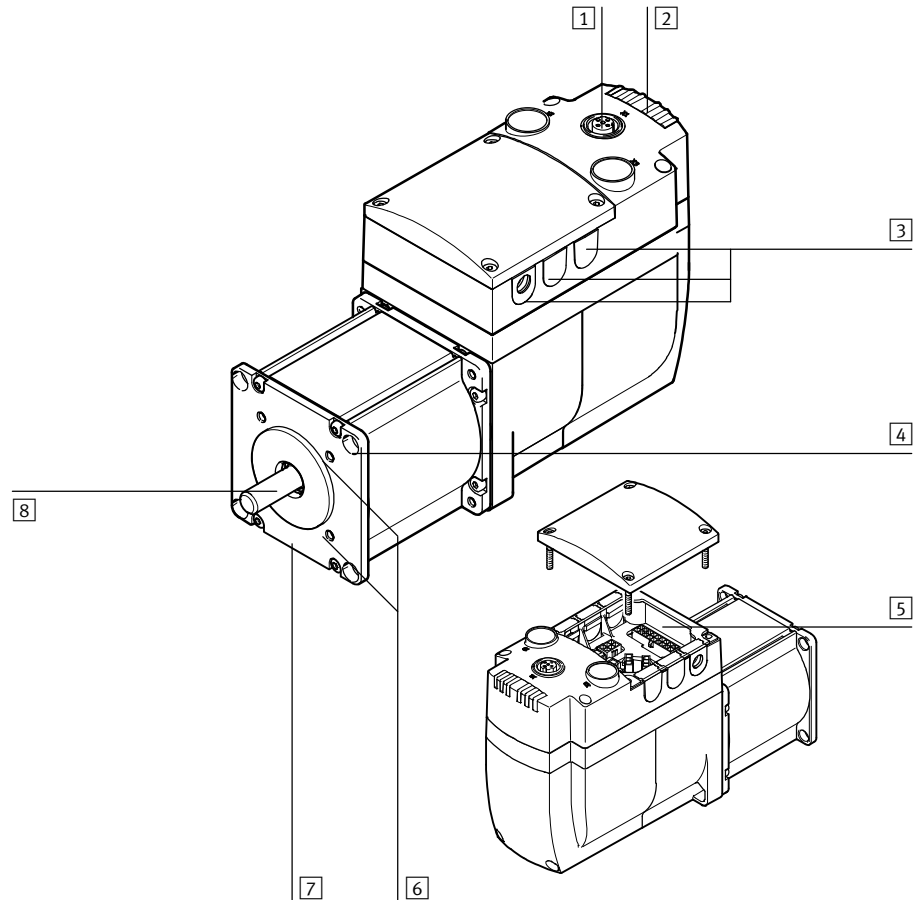

- 1 [X1]: Ethernet interface (M12 socket)
- 2 LED light guide (6x) – 2 used
- 3 Cable throughfeed of the terminal box
- 4 Through-hole for mounting (4x)

- 5 Plug connectors (→ Fig. 2.4)
- 6 Mounting thread (4x) thread M4
- 7 Motor flange
- 8 Shaft

Fig. 2.3 Control section and connections

The following plug connectors are below the cover:

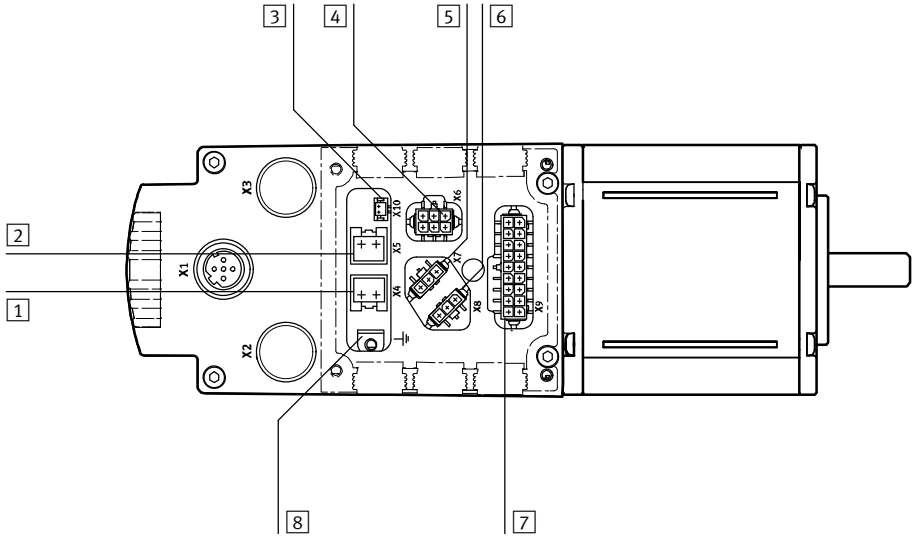

- | | |
|--|---|
| <p>1 [X4]: Power supply</p> <p>2 [X5]: Braking resistor</p> <p>3 [X10]: External battery
(only EMCA-EC-...-1TM)</p> <p>4 [X6]: STO interface (safe torque off)</p> | <p>5 [X7]: Reference or limit switch 1¹⁾</p> <p>6 [X8]: Reference or limit switch 2¹⁾</p> <p>7 [X9]: I/O interface</p> <p>8 central FU connection</p> |
|--|---|

1) Switch function (reference or limit switch) and switch type (normally closed or normally open), configurable with FCT

Fig. 2.4 Electrical connections under the cover

2.4 Drive functions

The integrated drive EMCA supports the following drive functions.

Drive functions	Brief description	→ Chapter
Homing	Performance of homing in order to determine the reference point	2.4.2
Jog mode	Manual operation of the drive in the positioning mode	2.4.3
Teach-in mode	Transfer of the current position (e.g. as a target position in the selected record)	2.4.4
Positioning mode	The EMCA calculates the positioning curve (point-to-point positioning) from the specified parameters (e.g. target position, acceleration, speed) and controls the motor accordingly.	2.4.5
Profile Velocity Mode	Processing of tasks with speed setpoints; the speed regulator and the current regulator process deviation between the “speed setpoint” and the “actual value for rotational speed”.	2.4.6
Force/torque mode	The current regulator processes deviation between the setpoint and the actual value for current.	2.4.7

Tab. 2.3 Drive functions

2.4.1 Dimension reference system

All drive functions are based upon a uniform dimensional reference system.

The direction of rotation is defined in the factory setting as follows (view toward the front surface of the motor shaft):

- Positive direction of rotation (+) corresponds to the clockwise direction of rotation of the motor.
- Negative direction of rotation (–) corresponds to the anti-clockwise direction of rotation of the motor.

With FCT, the direction of rotation can be adapted (→ FCT, page “Application Data”, tab “Environment”, option “Inverse Rotation Polarity”).

Example: rotary drives with limited positioning range

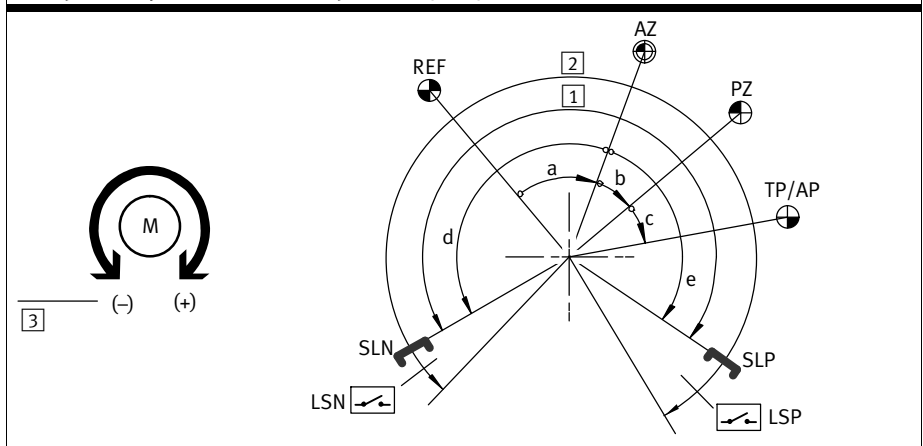

REF	Reference point (Reference point)
AZ	Axis zero point (Axis zero point)
PZ	Project zero point (Project zero point)
SLN	Software limit negative (Software limit negative)
SLP	Software limit positive (Software limit positive)
LSN	Negative limit switch (hardware) (Limit switch negative)
LSP	Positive limit switch (hardware) (Limit switch positive)
TP	Target position (Target position)
AP	Actual position (Actual position)
a	Offset axis zero point (AZ)
b	Offset project zero point (PZ)
c	Offset target/actual position (TP/AP)
d	Optional: offset negative software end position (SLN) ¹⁾
e	Optional: offset positive software end position (SLP) ¹⁾
1	Usable range
2	Work range of the drive (positioning range)
3	Direction of rotation with factory setting, looking at the front surface of the motor shaft

1) If an axis is configured with an unlimited work range, no software end positions can be parameterised.

Tab. 2.4 Dimension reference system – example of rotary drives

The direction of movement of load is dependent on the axis structure (e.g. of the gearbox).



Recommendation: check direction of movement in jog operation. If required, activate reversing of rotation to reverse the direction (→ FCT, page “Application Data”, tab “Environment”, option “Inverse Rotation Polarity”).

Example: Linear drives with limited working stroke

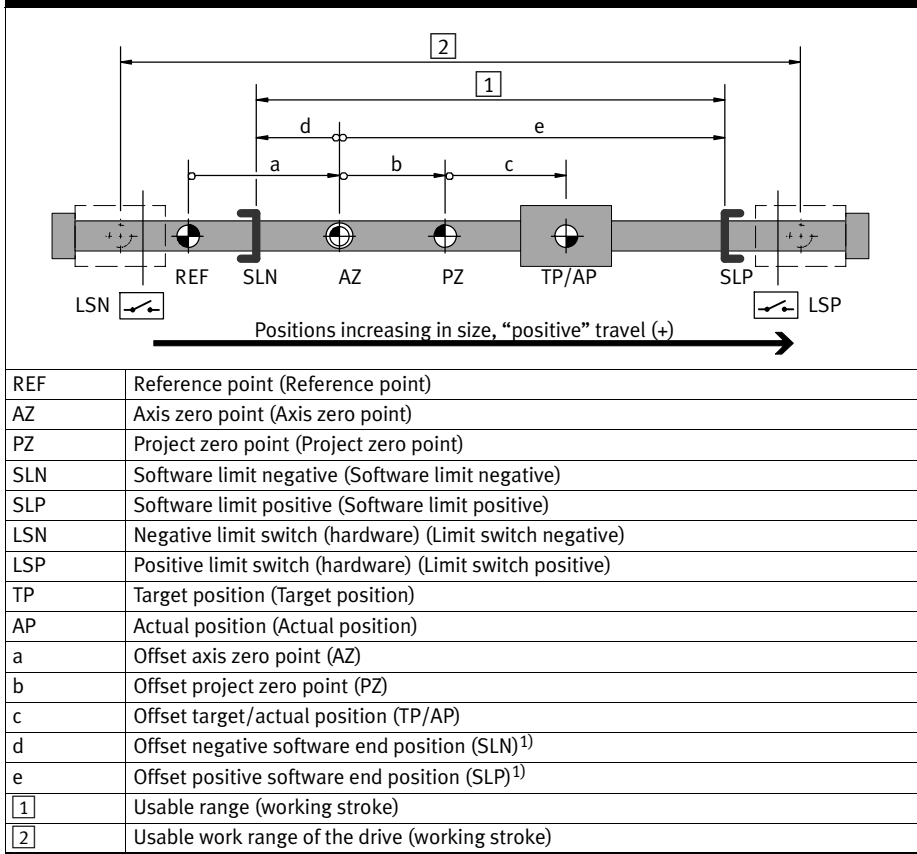

1) If an axis is configured with an unlimited work range, no software end positions can be parameterised.

Tab. 2.5 Dimension reference system – example, linear drives

Calculation rules for the dimension reference system

Point of reference	Calculation rule		
Axis zero point	AZ	= REF + a	
Project zero point	PZ	= AZ + b	= REF + a + b
Negative software end position	SLN	= AZ + d	= REF + a + d
Positive software end position	SLP	= AZ + e	= REF + a + e
Target position/actual position	TP/AP	= PZ + c	= AZ + b + c = REF + a + b + c

Tab. 2.6 Calculation rules for the dimension reference system

Limit switch LSN/LSP (hardware)

Limit switches limit the absolute usable range of the drive. The switching function “N/C contact” or “N/O contact” can be parameterised dependent on the limit switch type. The reaction of the device to limit switch signals can be parameterised with the FCT error management. A distinction is made thereby between the following cases:

- Limit switch positive active (message 07_h)
- Limit switch negative active (message 08_h)

For additional information on determining the behaviour → FCT error management.

The drive is blocked in the positioning direction of the active limit switch. As soon as the limit switch is active, travel is possible only in the reverse direction after acknowledgment of the error.

Software end position SLN/SLP

Delineation of an area of use within the operating area takes place through parameterisation of software end positions. The position is specified relative to the axis zero point AZ.



Note

Movement to fixed stops is not permitted during operation.

- Limit operating area through software end positions.
- Establish software end positions sufficiently far away from the mechanical stops.

The controller checks before the start whether the target position of the command record lies between the software end positions SLN/SLP. If a target position lies outside this range, the position set is not executed and the parameterised error response is triggered.

Before the software end position is reached, the drive is braked according to the error response, so that the software end position is not passed. After stopping, the positioning direction is blocked.

If the controller is not released, the software end positions are not monitored. If the drive is moved manually behind a software end position, after release of the controller, only travel toward the usable range is possible. If the target of the next positioning motion is even further outside the usable range, a corresponding error is reported. If the target of the next positioning motion lies within the usable range, travel can take place into the usable range without error.

Parameterisation of the following error messages can influence behaviour if the software end positions are violated: 11_h, 12_h, 13_h, 14_h, 29_h, 2A_h.

For additional information on determining the behaviour → FCT error management.

2.4.2 Homing

In homing, the reference point of the dimensional reference system is determined. All points of reference and drive limits of the dimension reference system refer directly or indirectly to the reference point. The reference point is the absolute point of reference for the axis zero point (→ Chapter 2.4.1). A drive function cannot be started without a successful homing run (exception: jogging). The homing sequence can be influenced through homing parameters (→ Tab. 2.16). The behaviour of the device regarding storage of the internal offset data determined in homing depends on the integrated encoder.

Encoder	Description
Single-turn absolute encoder (EMCA-EC-...-1TE)	The reference point is stored only temporarily and is lost with each interruption of the supply voltage. Homing must be carried out again each time the supply voltage is switched on.
Multi-turn absolute measurement system (EMCA-EC-...-1TM)	Capacitors supply the multi-turn absolute measurement system with power after shut-down. When the supply voltage is switched on, the capacitors are automatically charged. In the completely charged condition, the multi-turn absolute measurement system can be supplied in this way for up to 7 days (charge duration, min. 24 hours). With the EADA-A-9 external battery from Festo, the duration is extended to up to 6 months. As long as the multi-turn absolute measurement system is supplied with power, position changes will continue to be detected even with the supply voltage switched off. If the energy supply drops off, e.g. due to a longer switch-off duration, detection is not possible. Homing must then be carried out again after the supply voltage is switched on.

Tab. 2.7 Encoder

Homing is started via:

- the I/O interface (→ Start command for record no. 0 starts homing)
- FCT (→ FCT Help)

The “Motion Complete” signal is inactive during homing. When homing is completed, “Motion Complete” becomes active. If the option “Travel to axis zero point” is active, “Motion Complete” becomes active only when the axis zero point is reached. After successful completion of homing, standstill monitoring is activated (→ Chapter 2.6.1).

For homing methods with index evaluation, the index must have an adequate distance from the switching edge of the switch (reference or limit switch). This prevents shifting of the reference point by an index, and thus a complete motor revolution, after repeated homing due to temperature influences or mechanical play.



Recommendation: FCT displays the distance between the switching edge and index (→ FCT, online tab “Homing”).

- Align the reference switch in the middle between two index signals.

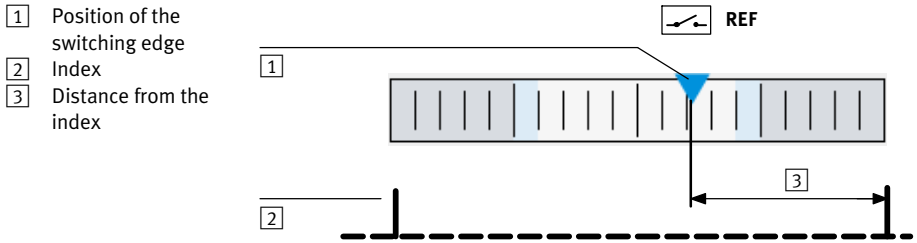

Fig. 2.5 Alignment of the reference switch during index evaluation – example

Homing methods

The homing method defines how the homing point REF is ascertained. Homing methods with index evaluation offer a higher repetition accuracy in determining the reference point.

Destination	CiA 402 ¹⁾		Brief description
Position Actual Value	DD _h	-35	Current position becomes the reference point.
Index			The next index of the encoder is searched for during the homing process. When successful, the position of the index becomes the homing point.
– Positive direction	22 _h	34	
– Negative direction	21 _h	33	
Stop			The mechanical stop is sought during homing. If the stop is detected in accordance with the parameterisation (force limit/torque limit, damping time), the position becomes the homing point.
– Positive direction	EE _h	-18	
– Negative direction	EF _h	-17	
Limit switch without index			During homing, the position of the limit switch is searched for. When successful, the position of the switch becomes the homing point.
– Positive direction	12 _h	18	
– Negative direction	11 _h	17	
Limit switch with index			During homing, the position of the limit switch is searched for. When successful, the drive travels back to the next index of the encoder. This position becomes the reference point.
– Positive direction	02 _h	02	
– Negative direction	01 _h	01	
Reference switch without index			During homing, the position of the reference switch is searched for. When successful, the position of the switch becomes the homing point.
– Positive direction	17 _h	23	
– Negative direction	1B _h	27	
Reference switch with index			During homing, the position of the reference switch is searched for. When successful, the drive travels back to the next index of the encoder. This position becomes the reference point.
– Positive direction	07 _h	7	
– Negative direction	0B _h	11	

1) The homing methods are based on the CANopen device profile CiA 402 V 3.0.

Tab. 2.8 Homing methods – overview

Current position (transfer as reference point)

1. The current position is taken as the homing point. A travel movement takes place only if the option “travel to the axis zero point” is active.
2. Optional: travel to the axis zero point (➔ Tab. 2.17).

Transfer current position (method DD_h; -35)

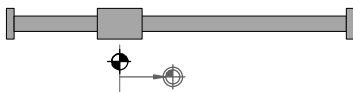

Tab. 2.9 Homing method – current position

Homing to index	
1. Search for the index of the encoder with search speed in the parameterised direction. The position of the next index is taken as the homing point.	
2. Optional: travel to the axis zero point (→ Tab. 2.17).	
Direction: positive (method 22 _h ; 34)	Direction: negative (method 21 _h ; 33)

Tab. 2.10 Homing method – homing to index

Homing to the stop

The stop is detected by a motor shutdown in combination with a sharp rise in the motor current and expiration of the damping time. After that, the stop position must be abandoned through travel to the axis zero point.

If the drive system does not have a stop (axis of rotation), homing will never be completed. The drive then travels continuously at the parameterised search speed.



Note

If the controller continuously controls against a stop, the temperature rises sharply and the controller shuts itself down.

- Set parameters for stop detection (force limit, damping time)
- Activate option “Travel from the homing point to the axis zero point”.
- The axis zero point must be set in such a way that the axis does not run against the stop/end-position cushioning in operation, even with overshwinging (e.g. ≥ 3 mm). A suitable value is preset at the factory. Do not change the presetting, if possible.
- Pay attention to the direction specification (algebraic sign) of the offset (away from the stop).



Note

Material damage due to shifted dimension reference system.

In the event of greatly reduced dynamic values (low parameterised maximum motor current) combined with high travelling resistance (e.g. due to frictional grip), there is a danger that the drive will come to a standstill and the controller will recognise a stop incorrectly.



Note

When homing to stop:

- Protect delicate stops by reducing the search speed.

Homing to the stop	
<ol style="list-style-type: none"> Search for the stop with search speed in the parameterised direction:¹⁾ <ul style="list-style-type: none"> Stop missing (rotary axis): The drive continues infinitely. Stop not recognised: EMCA regulates against the stop, shuts down if temperature rises above its defined limit. Stop detected: position is adopted as the homing point. Travel to the axis zero point²⁾ 	
Direction: positive (method EE _h ; -18)	Direction: negative (method EF _h ; -17)

- Limit switches are ignored during travel to the stop.
- In this homing method, the option "Travel to axis zero point" is always active (→ Tab. 2.17).

Tab. 2.11 Homing method – homing to stop

Homing to limit switch

Homing to limit switch without index	
<ol style="list-style-type: none"> If the limit switch is not actuated: Search for the limit switch with search speed in the parameterised direction. If the switch is detected, the next step takes place (→ 2.). If the limit switch is already actuated, the next step takes place (→ 2.). If the limit switch is not found: <ul style="list-style-type: none"> For rotary drives without stop: The drive continues infinitely. For drives with stop: Travel to stop, stop detection, termination of homing with malfunction message 0x22 (FCT code). Limit switch detected: Search for reference point at creep speed opposite to the parameterised direction until the limit switch is again unactuated. This position is taken as the reference point. Optional: travel to the axis zero point (→ Tab. 2.17). 	
Direction: positive (method 12 _h ; 18)	Direction: negative (method 11 _h ; 17)

Tab. 2.12 Homing method – Homing to limit switch without index

Homing to limit switch with index

1. If the limit switch is not actuated: Search for the limit switch with search speed in the parameterised direction. If the switch is detected, the next step takes place (→ 2.).
 If the limit switch is already actuated, the next step takes place (→ 2.).
 If the limit switch is not found:
 - For rotary drives without stop: The drive continues infinitely.
 - For drives with stop: Travel to stop, stop detection, termination of homing with malfunction message 0x22 (FCT code).
2. Limit switch detected: Search for reference point at creep speed opposite to the parameterised direction until the limit switch is again unactuated, and after that the first index is detected. This position is taken as the reference point.
3. Optional: travel to the axis zero point (→ Tab. 2.17).

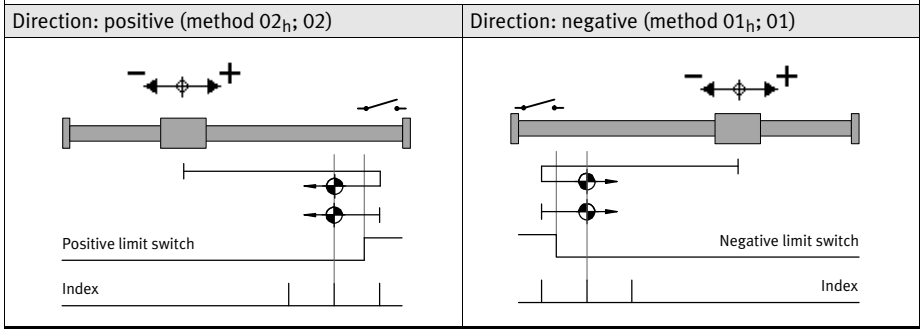

Tab. 2.13 Homing method – Homing to limit switch with index

Homing to reference switch

Homing to reference switch without index	
<p>1. If the reference switch is not actuated: Search for the reference switch with search speed in the parameterised direction. If the switch is detected, the next step takes place (→ 2.). If the reference switch is already actuated, the next step takes place (→ 2.). If the reference switch is not found:</p> <ul style="list-style-type: none"> – For rotary drives without stop: The drive continues infinitely. – For drives with stop: Travel to stop, stop detection, search in reverse direction <ul style="list-style-type: none"> – Switch in opposite direction not found: termination with error message 0x22 (FCT code) <p>2. Reference switch detected: Search for reference point at creep speed opposite to the parameterised direction until the reference switch is again unactuated. This position is taken as the reference point.</p> <p>3. Optional: travel to the axis zero point (→ Tab. 2.17).</p>	
Direction: positive (method 17h; 23)	Direction: negative (method 1Bh; 27)
<p style="text-align: center;">Reference switch</p>	<p style="text-align: center;">Reference switch</p>

Tab. 2.14 Homing method – homing to reference switch without index

Homing to reference switch with index

1. If the reference switch is not actuated: Search for the reference switch with search speed in the parameterised direction. If the switch is detected, the next step takes place (➔ 2.).
 If the reference switch is already actuated, the next step takes place (➔ 2.).
 If the reference switch is not found:
 - For rotary drives without stop: The drive continues infinitely.
 - For drives with stop: Travel to stop, stop detection, search in reverse direction
 - Switch in opposite direction not found: termination with error message 0x22 (FCT code)
2. Reference switch detected: Search for reference point at creep speed opposite to the parameterised direction until the reference switch is again unactuated, and after that the first index is detected. This position is taken as the reference point.
3. Optional: travel to the axis zero point (➔ Tab. 2.17).

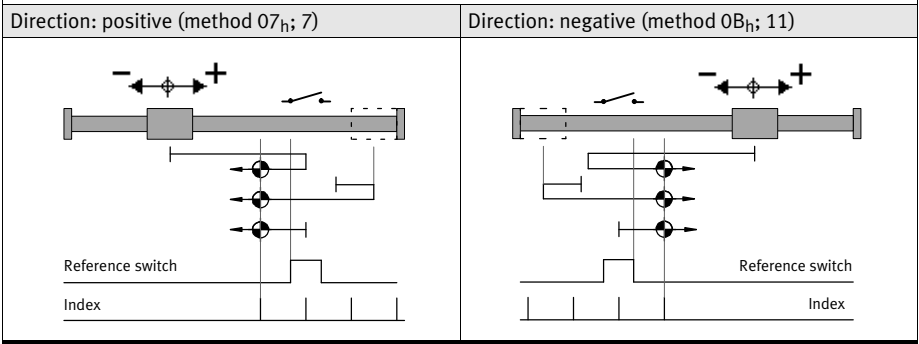

Tab. 2.15 Homing method – homing to reference switch with index

Homing parameters

The following parameters are effective when executing homing, depending on the homing method:

Homing parameter	Description
Target (Target)	Homing method (→ Tab. 2.8)
Direction (Direction)	
Search speed (Search Velocity)	Speed of searching travel to the defined target
Creep speed (Crawling Velocity)	Speed for crawling travel to the reference point (only for methods with reference or limit switch)
Travel speed (Drive Velocity)	Travel speed for the option “Drive to axis zero point”
Acceleration (Acceleration)	Acceleration and deceleration for all phases of reference travel
Axis zero point (Axis Zero Point)	The distance of the axis zero point from the reference point in positive or negative direction (offset)
Force limit (linear axis) or torque limit (Force Limit/Torque Limit)	Percentage specification of force (with reference to the parameterised base value of the motor current) at which impact detection is effective
Damping time (Message Delay)	Time period in which the force must lie above the force limit so that a stop is considered detected

Tab. 2.16 Homing parameters



- Select low search/crawl speed to enable the target points to be identified as accurately as possible.
- Set deceleration high enough to prevent the targets from being overrun too far during the search run.
- Use the default settings, if possible.

Homing option	Function
Travel to axis zero point after homing	
– Active ¹⁾	When homing is concluded, the drive automatically travels to the axis zero point.
– Inactive	The drive remains position-controlled at the reference point.

1) With the homing method “Homing to stop”, this option is always active.

Tab. 2.17 Homing option

2.4.3 Jog mode

In jog operation, the drive can be moved to any position. The drive is moved during jogging until the jogging signal is present. For referenced drives, the limits are determined by the software end positions. For unreferenced drives, limit switches or stops represent the limits.

Jogging supports the following functions:

- Approaching teach positions (e.g. during commissioning)
- Drive free running (e.g. after a system malfunction)
- Manual positioning as a normal operating mode (manually operated feed)

Jogging can be influenced with the following parameters:

Parameters	Description
Crawling speed (Crawling velocity)	Setpoint value for the speed when starting a jog movement
Duration of crawling (Slow moving time)	Setpoint value for the duration of crawling
Max. speed (Maximum velocity)	Maximum speed at the end of slow-moving time
Acceleration (Acceleration)	Setpoint value for acceleration phases and the deceleration phase
Max. permitted following error (Maximum following error)	Value for the permissible following error for jog movement
Damping time (Message delay)	A fault is generated if the following error is present for longer than the time parameterised here.

Tab. 2.18 Parameters for jog operation

Jogging transpires as follows (→ Fig. 2.6):

- Upon detection of the jog signal (Jog+ or Jog-), the drive travels at crawling speed in the corresponding direction.
- If the jog signal continues after the end of the slow-moving time, the drive accelerates to jog speed. Bigger strokes can thus be completed more rapidly.
- With a trailing edge of the jog signal, the drive is braked to a standstill.

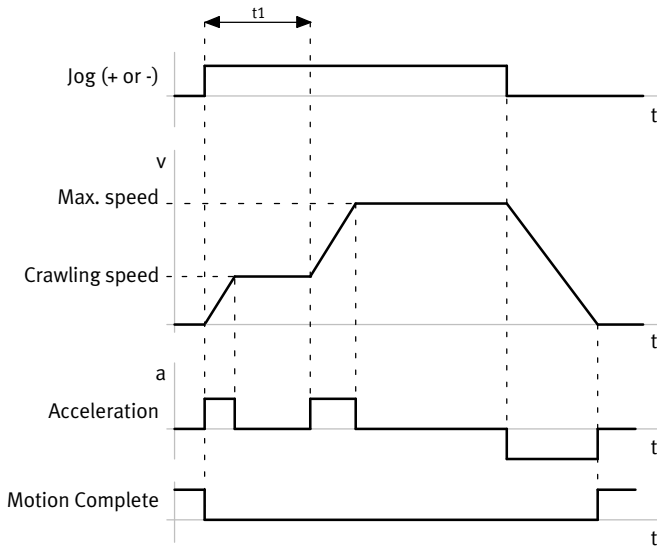

t_1 : Crawling duration

Fig. 2.6 Jogging – example

2.4.4 Teach-in mode

During teaching, the current position of the drive is taken as the absolute position value. For teaching via the I/O interface, the position value can be taken as the target position. The record must be a type PA record (positioning to absolute position). For teaching via FCT, the position value can be taken over for the following parameters:

- Target position of the currently selected record; the record must be of the type PA (positioning onto absolute position)
- axis zero point
- project zero point
- upper software end position
- lower software end position
- Position comparator of the currently selected record — lower limit and upper limit

The drive does not have to stand still for teaching. But inaccuracies of several millimetres can result even at low speeds, due to the usual cycle times of a PLC and the EMCA. The teach procedure can be carried out via the I/O interface or with the FCT.

When teaching with FCT, the parameter to be taught must first be selected in FCT. The Teach process runs in the following steps:

1. Bring drive into position (e.g. through jogging → Chapter 2.4.3).
2. Initiate “Teaching” command. The current position is then taken over.



For information on teaching with FCT → Plug-in help for the FCT.



Note

When teaching with FCT, observe the notes in the plug-in help.

2.4.5 Positioning mode

The positioning mode makes it possible to reach a target position via a defined path.

To enable this, the drive calculates a time-optimised path curve, in which the following parameters are considered, among others:

- performance of the electric drive
- limits for protection of the mechanical system
- requirements from the application that were parameterised by the user (e.g. smoothing during transport of liquid media)

The path course of a positioning order is largely influenced by the following parameters:

Parameters	Description
Position (Position)	Destination specification (specification of a route or absolute position → Tab. 2.20)
Speed (Velocity)	Setpoint value for speed
Acceleration (Acceleration)	Setpoint value for acceleration
Deceleration (Deceleration)	Setpoint value for deceleration ¹⁾
Jerk acceleration (Jerk for acceleration)	Maximum value for the jerk during the acceleration phase ²⁾
Jerk Deceleration (Jerk for deceleration)	Maximum value for the jerk during the deceleration phase ¹⁾²⁾

1) Separately adjustable in FCT if the asymmetric ramp generator has been activated

2) The jerk in [m/s³] is the first derivative of the acceleration. Lower values cause gentler starting and braking action.

Tab. 2.19 Parameters for influencing the movement course

A theoretical progression is calculated from the parameters before a positioning order is executed. The calculated path course remains unchanged until the end of the positioning order. While a positioning order is being carried out, the deviation between the setpoint position based on the previously calculated path course and the actual position is calculated and monitored (→ Chapter 2.6.1, following error monitoring).

Destination specification	Description
Absolute	Position, referenced to the axis zero point
Relative to the setpoint position	Distance referenced to the last setpoint position
Relative to the actual position	Distance referenced to the current position (actual position)

Tab. 2.20 Variants of the destination specification in positioning mode

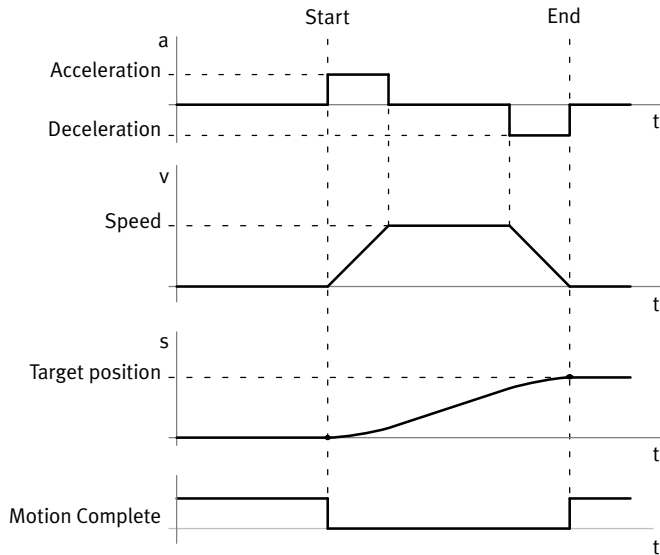

Fig. 2.7 Setpoint value course – example: starting speed and setpoint final speed 0 mm/s, without smoothing

Start speed

The speed when the order is started can be influenced by the previous order (→ Chapter 2.5, record switching, record chaining). The speed at the start of an order can therefore be 0 or $\neq 0$.

Final Speed

The “final speed” parameter establishes the speed at which the order should be ended at the target position. As a result, a following record can be executed with a defined initial speed.

Target recognition

The behaviour when the target position is reached depends on the “final speed” parameter.

Final speed parameter	Motion Complete (Target recognition)	Behaviour after target recognition
= 0	The positioning order is considered ended when the actual position is located in the target window for the established damping time.	As long as no other drive function is executed, the drive will stop at the target position in a position-controlled manner. Standstill monitoring is activated (→ Chapter 2.6.1).
≠ 0	The positioning order is considered complete when the target position has been reached or passed.	The drive continues with the final speed of the positioning order, without monitoring of the deviation. The force is limited to the maximum value defined in the position record.

Tab. 2.21 Target recognition in positioning mode

Additional parameters for order processing

Parameter	Description
Start Condition (Start Condition)	Reaction to a start signal if the current order has not been ended yet (record switching → Tab. 2.32)
Extra Load (Extra Load)	Payload that is transported in addition to the base load
Torque Feed Forward (Torque Feed Forward)	Adjustment of the motor setpoint current by the set percentage (for greater dynamic response with large loads) The value must be determined experimentally.
Force/Torque Limitation (Force Limit/ Torque Limit)	Limitation of the force (linear drive) or the torque (rotational drive) that can be generated during execution of the order
Max. Following Error (Max. Following Error)	Determination when the “following error” message should be output (→ Fig. 2.16)
Position comparator (Position Comparator)	Monitoring of a position window (→ Chapter 2.6.2)
Speed Comparator (Velocity Comparator)	Monitoring of a velocity window (→ Chapter 2.6.2)
Time Comparator (Time Comparator)	Monitoring of a time window that starts with the beginning of the order execution (→ Chapter 2.6.2)
Force/Torque Comparator (Force Comparator/ Torque Comparator)	Monitoring of a force or torque window (→ Chapter 2.6.2)
Condition (Condition)	Step enabling condition that must be fulfilled before the subsequent order is started (→ Chapter 2.5.2)
Start delay (Start Delay)	Waiting time that expires before the record is started from a record chaining (→ Chapter 2.5.2)

Parameter	Description
MC visible (MC visible)	Signal “Motion Complete” between the individual records of a record chaining; the signal length is influenced by the “Record Delay” parameter (→ Chapter 2.5.2).
Final Speed (Final Velocity)	The final speed at which the order should be ended at the target position; the drive can thus start a subsequent order at this speed without coming to a standstill.
Following set (Following Set)	Record number of the next record (→ Chapter 2.5.2)

Tab. 2.22 Additional parameters for order processing – example, record and direct mode

2.4.6 Speed mode

The speed mode permits regulation of the speed (linear drive) or rotational speed (rotary drive). The path course is largely influenced by the following parameters:

Parameter	Description
Speed (Velocity)	Target specification for speed
Acceleration (Acceleration)	Setpoint value for acceleration
Deceleration (Deceleration)	Setpoint value for deceleration ¹⁾
Jerk Acceleration (Jerk for Acceleration)	Maximum value for the jerk during the acceleration phase
Jerk Deceleration (Jerk for Deceleration)	Maximum value for the jerk during the deceleration phase ¹⁾
Force Limiter (Force Limit)	Limits the maximum force

1) Separately adjustable in FCT if the asymmetric ramp generator has been activated

Tab. 2.23 Parameters for influencing the movement course

As in positioning mode, a theoretical path course is calculated from the parameters for the speed mode prior to execution (→ Chapter 2.4.5). This path course remains unchanged until the end of the order. While the order is being carried out, the deviation between the setpoint speed based on the initially calculated path course and the actual speed is calculated and monitored (→ Chapter 2.6.1, following error monitoring).

Start speed

The speed when the order is started can be influenced by the previous order (→ Chapter 2.5, record switching, record chaining). The speed at the start of an order can be 0 or ≠ 0.

Target recognition

Motion Complete (Target recognition)	Behaviour after target recognition
An order in speed mode is considered finished when the actual speed is inside the target speed window for the duration of the parameterised damping time.	As long as no other drive function is executed, the drive will continue to be controlled by the setpoint speed. Monitoring of the speed deviation remains active until a new drive function is executed. The force is limited to the maximum value specified in the speed record. The stroke limit remains active.

Tab. 2.24 Target recognition in velocity mode

Variants

The following variants of speed regulation are available:

- speed regulation without stroke limit
- speed regulation with stroke limit

Parameter	Description
Stroke limit (Stroke Limit)	Limits the distance that may be travelled during execution of the order. When the stroke limit is reached, the device reacts as follows: <ul style="list-style-type: none"> – The drive is braked down to a stop using the parameterised Quick-Stop deceleration function. – Although the target speed has not yet been reached, the “Motion Complete” signal is set (➔ Fig. 2.8 and Fig. 2.10). If no other drive function is to be executed, the drive will stop in a position-controlled manner. Standstill monitoring is activated.

Tab. 2.25 Stroke limit parameter

Example: Target speed was not reached – without jerk limitation

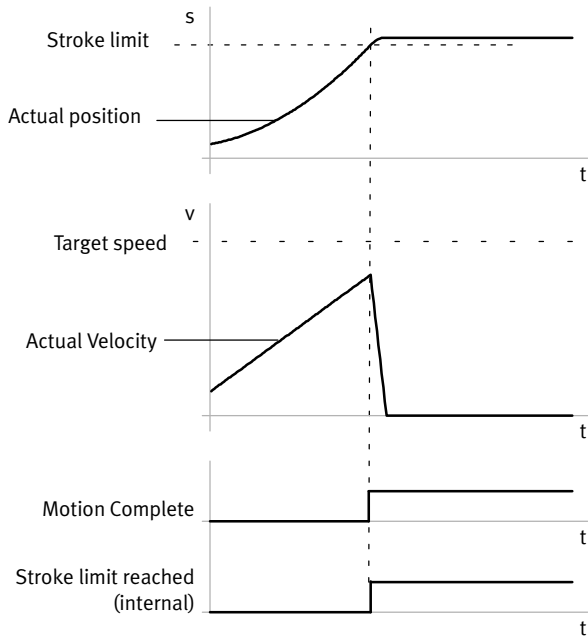

Fig. 2.8 Stroke limitation reached before target speed – without jerk limitation

Example: Target speed was reached – without jerk limitation

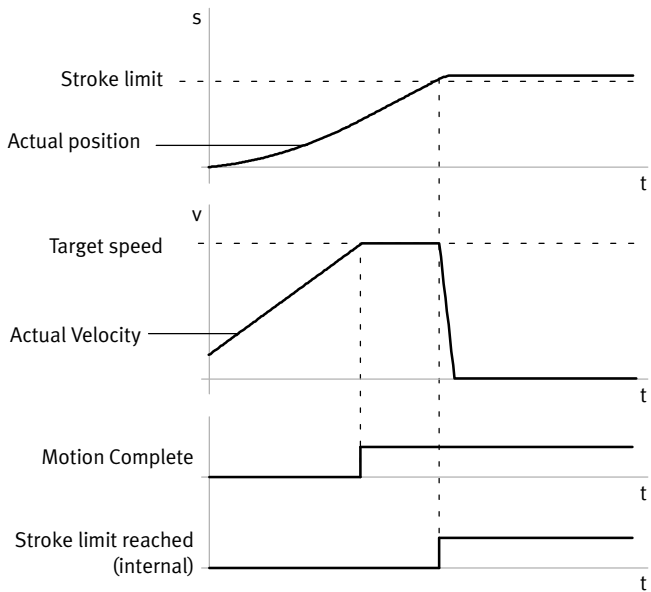

Fig. 2.9 Stroke limit reached after target speed reached – without jerk limitation

Example: Target speed was reached – with jerk limitation

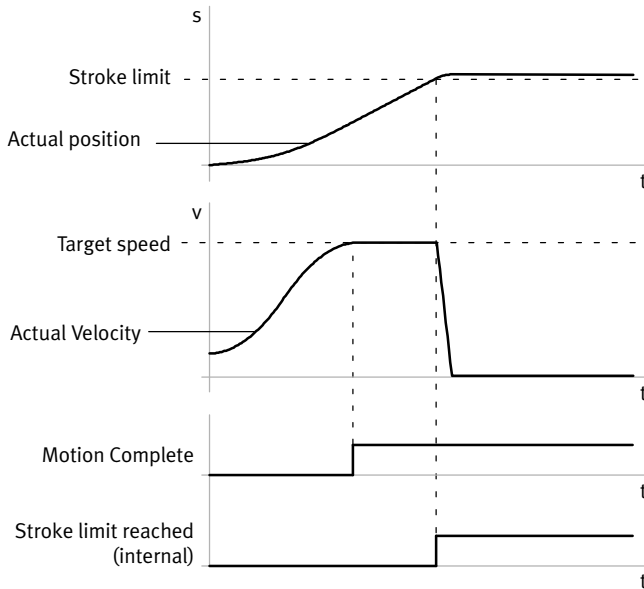

Fig. 2.10 Stroke limit reached after target speed reached – with jerk limitation



Additional parameters for order processing → Tab. 2.22.

2.4.7 Force/torque mode

The force/torque mode permits force control. The motor force is controlled indirectly through regulation of the motor current. The generated force is theoretically calculated over the measured current (Force is proportional to the motor current). Depending on the mechanical system of the drive, this results in a torque or linear force.

The target specification is based on a percentage of the parameterised base value of the motor current. The actual force at the axis must be checked at commissioning using external measuring equipment. Deviations between the actual and the desired force can be reduced by adjusting the parameterisation.

The path course of an order in force/torque mode is largely influenced by the following parameters:

Parameter	Description
Force (Force)	Target specification for force (in % of the parameterised base value of the motor current)
Speed (Velocity)	Setpoint value for speed
Acceleration (Acceleration)	Setpoint value for acceleration
Deceleration (Deceleration)	Setpoint value for deceleration ¹⁾

1) Separately adjustable in FCT if the asymmetric ramp generator has been activated

Tab. 2.26 Parameters for influencing the movement course in force/torque mode

Start force

The actual speed at the start of the order can be influenced by the previous order. The actual force at the start of the order can be 0 or $\neq 0$.

Target recognition

Motion Complete (Target recognition)	Behaviour after target recognition
An order in the force/torque mode is considered finished when the calculated actual force is located in the target window for the established damping time.	As long as no other drive function is executed, the drive will continue to be controlled by the setpoint force. The speed remains limited to the maximum value specified in the order. The stroke limit remains active.

Tab. 2.27 Target recognition in force/torque mode

Variants of the force/torque mode

The following variants of the force/torque mode are available:

- force/torque mode without stroke limit
- force/torque mode with stroke limit.

Parameter	Description
Stroke limit (Stroke Limit)	Limits the distance that may be travelled during execution of the order. When the stroke limit is reached, the device reacts as follows: <ul style="list-style-type: none"> – The “Stroke limit reached” signal is set. – The drive is braked down to a stop using the parameterised Quick-Stop deceleration function. If no other drive function is to be executed, the drive will stop at the stroke limit in a position-controlled manner. Standstill monitoring is activated and the “Motion Complete” signal is set.

Tab. 2.28 Stroke limit parameter

Additional parameters for order processing



Additional parameters for order processing → Tab. 2.22.

2.4.8 Stop (halt), Quick-Stop

Stop (halt)

In a stop, the drive is braked with the parameterised deceleration of the active position set until standstill. The drive stops in a position-controlled manner. Standstill monitoring is activated. A stop (halt) can be triggered via:

- the input “Stop” [X9.15]

The reaction to the Stop signal (halt) depends on the current control mode (positioning mode, speed mode or force/torque mode).

Stop (halt) in ...	Description
Positioning mode	<p>In positioning mode, the Stop signal (halt) first results in an intermediate stop. Intermediate stop means:</p> <ul style="list-style-type: none"> – The “Motion Complete” signal is not set. – The order is interrupted (considered not finished). The job can be continued (→ Chapter 2.8.8). <p>The positioning order can be interrupted through the “Delete remaining path” signal. The intermediate stop then becomes a stop (→ Chapter 2.8.9). Stop means:</p> <ul style="list-style-type: none"> – The “Motion Complete” signal is set. – The order is discontinued and considered completed.
Speed mode or force/torque mode	<p>In speed or force/torque mode, the Stop signal (halt) results in a stop. Stop means:</p> <ul style="list-style-type: none"> – The “Motion Complete” signal is set. – The order is discontinued and considered completed.

Tab. 2.29 Stop drive

Quick-Stop (Fast stop)

In a Quick-Stop, the drive is braked down to a stop using the parameterised Quick-Stop deceleration function. Quick-Stop is triggered in the following cases:

- Withdrawal of controller enable. After completion of the Quick-Stop deceleration, the drive is blocked (output stage switched off). The actuator is uncontrolled.
- For errors for which the “Quick-Stop deceleration” error reaction has been parameterised (→ Error management)
- Achievement of the stroke limit (speed mode, force/torque mode)

2.4.9 Holding brake (only EMCA-EC-...-...-B)

The EMCA-EC-...-B has an EC motor with holding brake. The holding brake is intended to hold the motor position/drive position in a state of rest and is only used at a standstill.



Note

Using the holding brake

Improper use of the holding brake causes increased wear of the brake disc, which results in a reduction of the holding torque. The holding function is therefore no longer guaranteed.



The holding brake cannot be replaced or repaired. In case of defect, the device must be completely replaced.

Build-up of the holding torque

The full holding torque of the brake is only built up through a small relative movement between the friction surface of the holding brake and the anchor plate. If there is an external torque load on the motor shaft, this results in a small rotation. This effect can be eliminated through repeated operation at low rotational speed.

Automatic control of the holding brake

The EMCA-EC-...-B controls the holding brake automatically. The holding brake is released when the controller is enabled. The holding brake is activated when the controller is blocked.

Manual release of the holding brake

When the controller is blocked, the holding brake can be released as follows:

- via the FCT (→ Online help)
- with High level at the input “Brake control/Delete remaining path”

Parameterisation

The inertia of the holding brake means that it takes a certain length of time to release and activate it. The behaviour of the device is adapted to the inertia of the holding brake by the following parameters (→ FCT, “Motor” page, “Brake control” tab).

Parameter	Description
Switch-on delay	<p>Delay before execution of the next order:</p> <ol style="list-style-type: none"> 1. When the controller is enabled, the holding brake is first released. The position controller takes over the control (actual position = setpoint position). 2. No orders are processed until the switch-on delay has elapsed, so that the holding brake can release completely. 3. After the switch-on delay has elapsed, orders are accepted. The holding brake should then be completely released.
Switch-off delay	<p>Delay prior to shut-down of the position controller:</p> <ol style="list-style-type: none"> 1. Removal of the controller enable triggers a quick-stop. If the setpoint speed is 0, the signal for closing the holding brake is given. 2. The drive is maintained in its current position until the end of the switch-off delay. 3. The position controller is switched off after expiration of the switch-off delay. The holding brake should then be completely closed.

Tab. 2.30 Parameterisation of the holding brake

The parameters for control of the holding brake are preset at the factory to appropriate values.

Recommendation: Do not change the factory setting, if possible.



Additional parameters for order processing → Tab. 2.22.

2.5 Operational principle for record selection

In the device, 64 command records can be stored (record 1 to 64). Record 0 is reserved for homing. Every stored record contains all required parameters for order processing. To execute an order, the controlling PLC only needs to transfer the record number to the output data. The device then executes the corresponding record with the next start signal. Besides the parameters for pure order processing, record selection offers the following options for influencing sequence control:

Options for sequence control	Parameter	Brief description
Record switching	– Start condition	A start condition can be defined for every stored record (e.g. with FCT). The start condition specifies what the reaction should be to a start signal for the record if the current order has not been ended yet (→ Tab. 2.32).
Record sequencing	– Condition (step enabling condition) – Start delay – MC visible – End speed – Following set	Several records can be linked with one another. These are executed with a start signal directly one after the other if the respective conditions for continuation are met (→ Chap. Tab. 2.33)

Tab. 2.31 Options for sequence control in record selection

2.5.1 Record switching

Record switching enables flexible switching between records. For each record saved, it is possible to define how the drive should behave if this record is started while, at the same time, another record is being executed (start conditions → Tab. 2.32).

Start condition	Description
Ignore (Ignore)	While the order is being executed, the start signal is ignored. The current order is completed. The order can only be started after the MC is active (new start signal required).
Waiting (Delay)	The current order is completed. The subsequent order addressed by the last start signal is only started after the current order has been completed (after the “Motion Complete” signal).
Interrupt (Interrupt)	The current order is interrupted immediately and the newly addressed order is executed directly.

Tab. 2.32 Possible settings for the “Start condition” parameter

Example: “Ignore” start condition

The start signal (here for record B) is ignored. The current order (here record A) is completed.

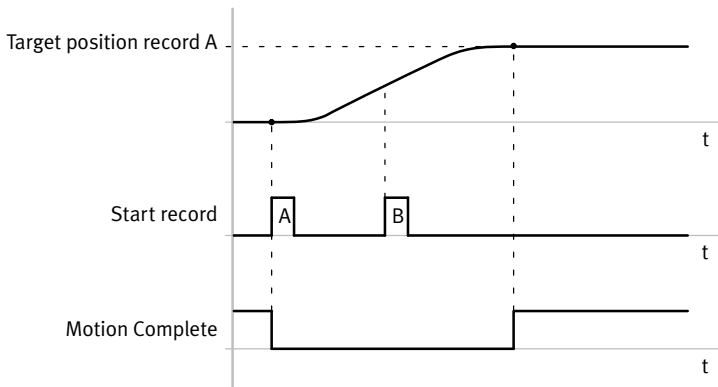

Fig. 2.11 “Ignore” start condition

Example: start condition “Waiting”

Initially, the start signals (here for records B and C) are ignored. The current order (here record A) is completed. Then the last order (here record C) is executed without another start signal.

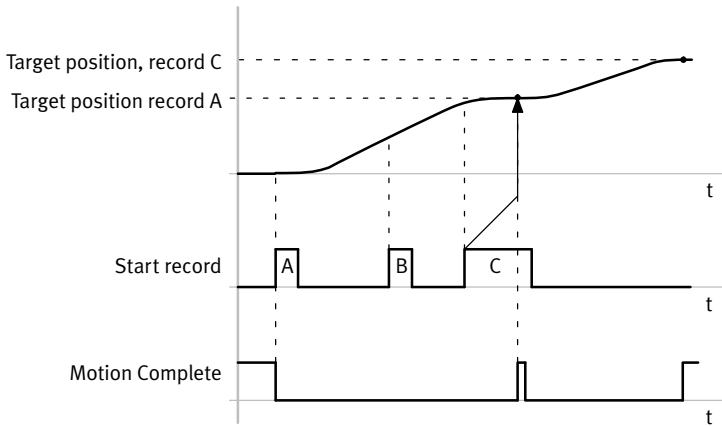

Fig. 2.12 Start condition “Waiting”

Example: start condition “Interrupt”

The current order (here record A) is interrupted immediately and the newly addressed order (here record B) is executed directly.

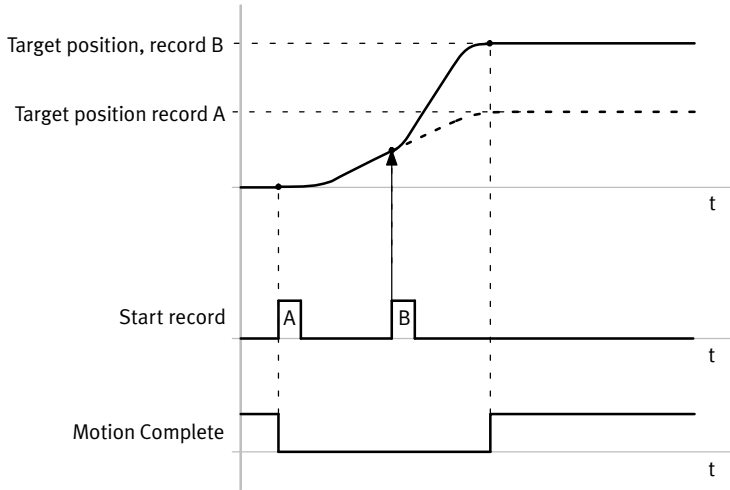

Fig. 2.13 Start condition “Interrupt”

2.5.2 Record sequencing

Record sequencing allows linking of records with each other. In every record, the number of the next record to be executed can be parameterised. If the step enabling condition is satisfied, the specified subsequent record is started. A record sequence is executed with the start of a record in the sequence without any further start command, up to the last record in the sequence. Record sequencing can be used to implement complex motion sequences, e.g.:

- positioning and clamping in a motion sequence
- travelling a speed profile
- executing a force profile for pressing procedures

The chaining sequence can be influenced by the following parameters:

Parameters	Description
Condition (Condition)	Indicates when the subsequent record should be started (step enabling condition)
Start delay (Start Delay)	Waiting time that expires before the record is started from a record sequencing.
MC visible (MC visible)	Specifies whether the “Motion Complete” message should be output upon ending of the record. The duration of the signal can be influenced by the “Start delay” parameter.
Final speed ¹⁾ (Final Velocity)	Final speed with which the record should be ended at the target position. If setpoint final speed is not equal to 0, the damping time for “Motion Complete” is ineffective. The final speed must be less than or equal to the parameterised maximum speed of the order.
Following set (Following Set)	Number of the record that should be started automatically when the condition is reached.

1) only in positioning mode

Tab. 2.33 Parameters for influencing the movement course

A comparator, for example, can be used as a condition. The following conditions are possible:

Condition (Condition)	The following record is started if ...
Motion Complete	... the signal “Motion Complete” becomes active
Position comparator active	... the current position is in the position window for the duration of the damping time
Speed comparator active	... the speed is within the defined speed window for the duration of the damping time
Force comparator active	... the force is in the force/torque window for the duration of the damping time
Time comparator active	... the length of time for which order processing is in the time window
Inactive	ends record sequencing

Tab. 2.34 “Condition” parameter (Condition)

Example: Record linking with final speed $\neq 0$ (positioning mode)

The following diagram shows the effect of the parameter "Final speed" on record sequencing. Final and setpoint speed for record A share the same value. Record B is started without start delay when the target position of record A is reached without considering the damping time for Motion Complete.

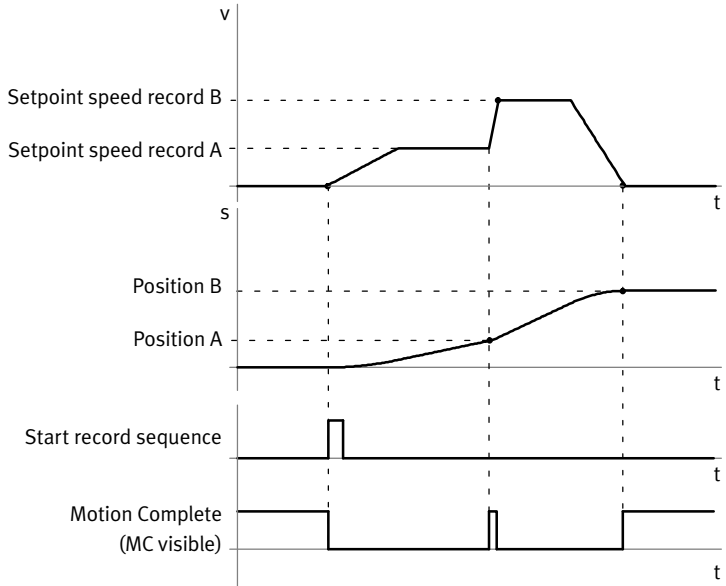

Fig. 2.14 Following record with final velocity $\neq 0$

2.6 Monitoring of the drive behaviour

The drive behaviour can be monitored and controlled by messages and comparators. Furthermore, the EMCA has internal protection functions, e.g. to protect internal components from damage in the event of operator error.

2.6.1 Dispatches

Messages can be output via the freely configurable digital output [X9.8] (→ Tab. 2.52).

Message	Brief description
Motion Complete (Target recognition)	...Signals the end of an order (target recognition)
Following error (Following error)	Only for jogging, positioning and speed mode: Monitors behaviour during the order (→ Fig. 2.16)
Standstill monitoring (Standstill monitoring)	Monitors behaviour after the end of the order (→ Fig. 2.17) Standstill monitoring is always active when the drive is controlled at a standstill. The drive is controlled at a standstill in the following cases: <ul style="list-style-type: none"> – after jogging – after completion of homing – after completion of a positioning order with final speed 0 – after completion of an order with stroke limiter
Comparator (Comparator)	Monitors a specific tolerance window during an order, e.g. for control of record sequences or for control of any other actions through the higher-order controller (→ Chapter 2.6.2.).

Tab. 2.35 Messages

Message “Motion Complete” (target recognition)

...The “Motion Complete” signals the end of an order (target recognition). A window is defined for each order type (position, speed or current control). When the actual value of the target variable is in the target window for the duration of the parameterised damping time, the message “Motion Complete” (target recognition) is triggered.

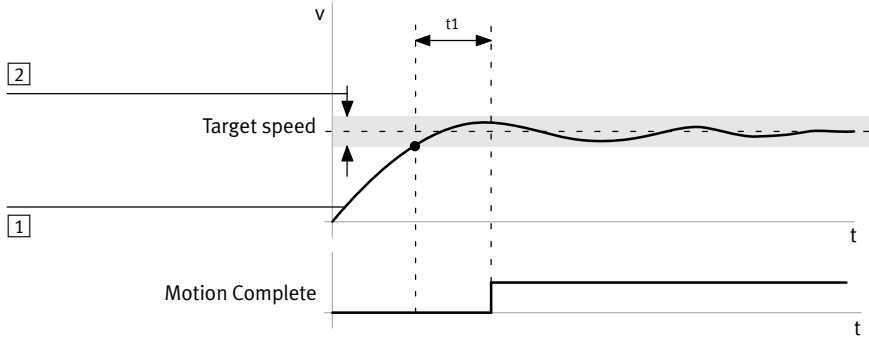

t1: Damping time Motion Complete

1 Actual Velocity

2 Target window

Fig. 2.15 Motion Complete – example, speed control

Message “Following error”

With position and speed adjustment, exceeding the maximum permissible following error can be monitored. A theoretical progression is calculated from the parameters of an order before it is executed (→ Fig. 2.16, 1). While carrying out an order, the variance between the calculated setpoint and the current actual value is monitored. The permitted difference (max. permissible following error) is established through parameterisation. The message “Following error” is activated after the damping time has expired if the difference between the setpoint and actual value of the current controlled variable (path, speed) lies outside the parameterised difference. If the following error has been configured as a warning, the message is automatically deleted when the actual value is again within the following error window.

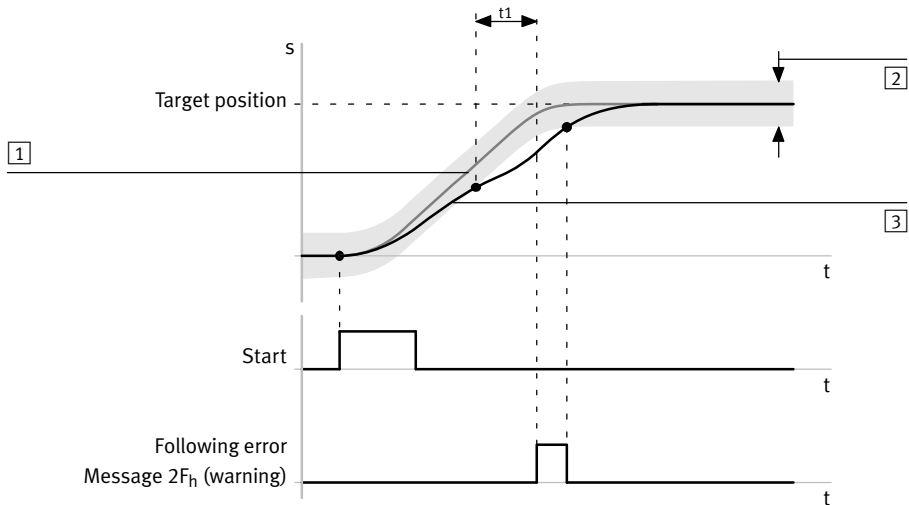

t1: Damping time for following error

1 Set positioning path

3 Actual positioning path

2 Following error window

Fig. 2.16 Time diagram: message “following error” - example, positioning control, warning

The error management of FCT permits parameterising the reaction to this message ($2F_h$) (→ FCT error management).

Message standstill monitoring

The standstill monitoring checks in position control if the drive is within the standstill window around the target position for the duration of the damping time (➔ Fig. 2.17).

After the target position is reached and the “Motion Complete” is reported, standstill monitoring is activated. If the drive is moved during active standstill monitoring, e.g. by external forces for the duration of the standstill monitoring time from the standstill window, the following response occurs:

- The EMCA issues the diagnostic message “Actual position lies outside the standstill window” (active = 1: Axis has left the standstill window; inactive = 0: Axis is located in the standstill window).
- The position controller attempts to return the drive to the standstill window.

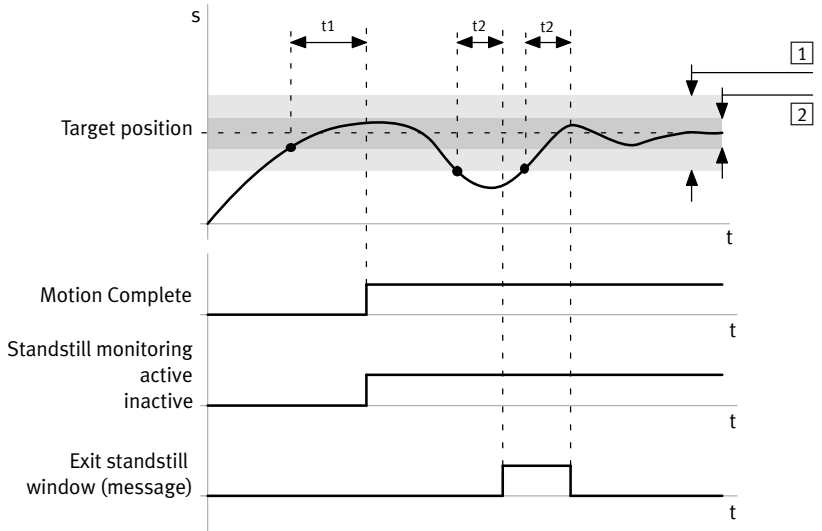

t1: Damping time Motion Complete

t2: Damping time, standstill monitoring

1 Standstill window

2 Target window

Fig. 2.17 Standstill monitoring - example

Standstill monitoring cannot be switched on and off explicitly. Standstill monitoring becomes inactive when the standstill window is set to the value 0.

The error management functionality of FCT makes it possible to parameterise the response to this message (37Fh) (➔ FCT error management).

2.6.2 Comparators

With comparators, certain characteristics of the drive behaviour can be monitored. It is hereby checked whether a value, e.g. the speed of the drive, lies within a defined range of values. The range of values is defined by a lower and an upper limit value. For position, speed and force comparators, a damping time is also established. The message is output if the value remains in the range of values for the duration of the damping period.



The device does **not** test whether the limit values make sense. If the lower limit value is greater than the upper limit value, the comparator message is never active.

Comparators can be used for record selection and, in direct mode, for monitoring. For record selection, the parameters of the comparators are administered in the position set (e.g. minimum value and maximum value of the monitoring window). For record sequencing, the comparators can be used as step enabling conditions (➔ Chapter 2.5, record sequencing).

For the direct mode, the parameters of the comparators are administered as global parameters for direct mode (presetting for direct mode).

The configurable digital output (➔ Tab. 2.49) is usable for the output of comparator messages. If the monitored value is in the monitoring window, the related comparator message is active. The configurable digital output is set when it is configured accordingly.

Outside the monitoring window, the comparator message is inactive and the output is reset.

Comparators	Brief description
Position comparator ¹⁾ (Position comparator)	Monitors a specified position window
Speed comparator ¹⁾ (Velocity comparator)	Monitors a specified speed window
Force Comparator ¹⁾ (Force comparator)	Monitors a specified force or torque window
Time comparator (Time comparator)	Monitors a time window that starts with the beginning of record execution

1) The comparator message is output only if the monitored value remains in the monitoring range for the duration of the set damping period.

Tab. 2.36 Comparators (overview)

Position comparator

The position comparator monitors a specified position window. The position comparator message becomes active when the following 2 conditions are fulfilled:

- The actual position is located within the parameterised position window (\geq minimum and \leq maximum).
- The first condition was fulfilled at least over the specified time period (damping time).

In all other cases the message is inactive.

When the drive leaves the position zone again, the message is reset immediately.

The position comparators can be used in positioning mode, speed mode and in force/torque mode.

Parameter	Description
Min.	Lower position limit (minimum) ¹⁾
Max.	Upper position limit (maximum) ¹⁾
Time	Dwell time within the position zone before the position comparator becomes active

1) The specified limits are always absolute positions (related to the project zero point).

If the minimum value is greater than the maximum value, the condition for the position comparator is never fulfilled.

Example of a position zone in the negative range: “-50 ... -40 mm”,

→ “-50 mm” must be entered as the minimum value and “-40 mm” as the maximum value.

Tab. 2.37 Parameters for the position comparator



The position limits are always specified in absolute values, even for relative position records.

Speed comparator

The message “Speed comparator active” is set when the following 2 conditions are fulfilled:

- The actual speed is within the parameterisable limits (\geq minimum and \leq maximum).
- The first condition was fulfilled at least over the specified time period (damping time).

In all other cases the message is inactive.

When the drive leaves the speed zone again, the message is reset immediately.

The speed comparators can be used in positioning mode, speed mode and in force/torque mode.

Parameter	Description
Min.	Lower speed limit (minimum) ¹⁾
Max.	Upper speed limit (maximum) ¹⁾
Time	Minimum dwell time within the speed zone before the speed comparator is active

1) The limit values can be both positive and negative. If the minimum value is greater than the maximum value, the condition for the speed comparator is never fulfilled.

Tab. 2.38 Parameters for the speed comparator

Force Comparator

The message “Force comparator active” is set when the following 2 conditions are fulfilled:

- The actual force calculated with the help of the measured current is within the parameterisable limits (\geq minimum and \leq maximum).
- The first condition was fulfilled at least over the specified time period (damping time).

In all other cases the message is inactive.

When the drive leaves the force zone again, the message is reset immediately.

The force comparators can be used in positioning mode, speed mode and in force/torque mode.

Parameter	Description
Min.	Lower force limit (minimum) ¹⁾
Max.	Upper force limit (maximum) ¹⁾
Time	Dwell time within the force zone before the force comparator becomes active

- 1) The limit values can be both positive and negative. The prefix here indicates the direction of the force. If the minimum value is greater than the maximum value, the condition for the force comparator is never fulfilled.

Tab. 2.39 Parameters for the force comparator

Time Comparator

The message “Time comparator active” is set when the following condition is fulfilled:

- The time since the start of the record is within the parameterisable limits (\geq minimum and \leq maximum).

In all other cases the message is inactive.

Parameter	Description
Min.	Lower time limit (minimum) ¹⁾
Max.	Upper time limit (maximum) ¹⁾

- 1) The limit values can only be positive. If the minimum value is greater than the maximum value, the condition for the time comparator is never fulfilled.

Tab. 2.40 Parameters for the time comparator

2.6.3 Protective functions

The EMCA has a comprehensive array of sensors that monitor the control section, power section, motor and external communication to ensure that they function perfectly. Some errors cause the control section to shut down the power section (output stage). The power section cannot be switched back on until the error has been eliminated and then acknowledged. The following protective functions promote operational reliability:

Protective functions	No. of the message	Brief description
Monitoring of the limit switch	07 _h , 08 _h	Monitors exceeding of the limit switches (→ Chapter 2.4.1)
Monitoring of the software end positions	11 _h , 12 _h , 29 _h , 2A _h	Monitors exceeding of the software end positions (→ Chapter 2.4.1)
Motor current (I ² t monitoring)	0E _h	Monitors power loss of the drive; If a maximum value is exceeded, a message is issued.
Voltage monitoring – Logic voltage – Intermediate circuit voltage	17 _h , 18 _h 1A _h , 1B _h	Detects undervoltages and overvoltages
Temperature monitoring	15 _h , 16 _h	The output stage temperature is measured with a temperature sensor. The output stage temperature and CPU temperature are monitored cyclically. If the temperature rises above a limit value, an error is triggered.
Braking resistor measured value	30 _h	The EMCA has an autonomous brake chopper with connection for an external braking resistor (connection [X5]). An internal braking resistor is not present. The EMCA detects in the switch-on phase whether an external braking resistor is connected. But a check of correct dimensioning does not take place. If no braking resistor is connected in the switch-on phase, the EMCA generates a corresponding diagnostic message (→ FCT error management). For applications that do not require a braking resistor, this diagnostic message can be classified as information (→ Tab. 2.42). The diagnostic message then has no external effect.

Tab. 2.41 Protective functions

2.6.4 Error management

The error management of the FCT makes it possible to parameterise the reaction to diagnostic messages of the device (→ FCT, page “Error Management”). These diagnostic messages can be classified as error, warning or information. The reactions to the diagnostic messages can be established dependent on the classifications made.

Classification	Description
Error (Error)	Errors always generate an error response (e.g. quick-stop deceleration). Errors must be acknowledged. Certain errors cannot be acknowledged until their cause has been remedied. Diagnostic messages classified as errors are displayed over the status LED (→ Chapter 6.2). For some errors, the error response can be parameterised with FCT (→ Error management of FCT).
Warning (Warning)	Warnings have no influence on the behaviour of the motor and do not need to be acknowledged. The cause of a warning should be eliminated to prevent the warning from resulting in an error. Messages classified as an error are displayed by the status LED (→ Chapter 6.2).
Information (Information)	Diagnostic messages classified as information are not displayed by the status LED. The diagnostic message can be stored in the diagnostic memory.

Tab. 2.42 Classifications of the diagnostic messages

Possible error responses	Description
Free run-out (Free-wheeling)	The output stage is switched off. The drive runs down.
Quick-stop deceleration (QS deceleration)	The movement is braked immediately with the parameterised quick stop deceleration (quick-stop braking ramp). Additional option ¹⁾ : Output stage on (Output stage on) or off
Record deceleration (Record deceleration)	Movement is stopped immediately with the deceleration parameterised in the current record. Additional option ¹⁾ : Output stage on (Output Stage on) or off
Finish record (Finish record)	The current record is finished normally (not cancelled). Additional option ¹⁾ : Output stage on (Output Stage on) or off (off)

1) For certain errors (→ FCT error management)

Tab. 2.43 Possible reactions to errors

With the “Save diagnosis” (Save Diagnosis) option, the system even can be stored in the diagnostic memory.



For additional information on determining error responses → FCT Help, keyword Error management.

2.6.5 Diagnostic memory

The EMCA has a non-volatile diagnostic memory. Diagnostic messages can be recorded in the diagnostic memory. Which diagnostic messages get recorded can be defined through the FCT error management function (➔ Chapter 2.6.4).

The diagnostic memory is designed as a ring memory with a capacity of 200 diagnostic messages. The relevant diagnostic messages are written consecutively to the diagnostic memory. Whenever the diagnostic memory is full, the oldest diagnostic message is overwritten when a new diagnostic message arrives (FIFO principle).

The diagnostic memory can be accessed by:

- FCT (see FCT help)
- Webserver (➔ Chapter 5.5 and 6.1).

2.7 Interfaces

The device has an Ethernet interface and an I/O interface. The device is parameterised via Ethernet interface. Depending on the parameterisation, control takes place via the I/O interface or the Ethernet interface.



Information for installation → chapter 4

2.7.1 Ethernet interface [X1]

The Ethernet interface [X1] permits the following:

- Configuration, parameterisation, commissioning, diagnostics and firmware download with FCT (→ chapter 5.2 and FCT Help)
- Diagnostics with the help of the web server via a web browser (→ chapter 5.5 and 6.1)
- Loading a parameter file via the web server (→ chapter 5.7) and with FCT
- Process coupling via Modbus[®] TCP with the device profile FHPP

Through the Ethernet interface, the following connections are possible:

Connections	Description
Point-to-point connection	The device is connected directly to the PC via an Ethernet cable.
Network connection	The device is connected to an Ethernet network.

Tab. 2.44 Options for connection

The device supports the following 3 methods of the IP configuration (based on IPv4):

Methods	Description
Active DHCP server (factory setting)	The device has a permanently parameterised IP configuration. If a PC configured as a DHCP client is connected to the device, the device automatically assigns an IP configuration to the PC. This method is especially suited for point-to-point connections. IP configuration with active DHCP server: <ul style="list-style-type: none"> – IP address: 192.168.178.1 – Subnet mask: 255.255.255.0 – Gateway: – (a gateway is not assigned) – Port: Web server 80, FCT 7508, Modbus[®]: 502
Obtain IP address automatically (DHCP client)	The device obtains its IP configuration from a DHCP server in your network. This method is especially suitable for networks in which another DHCP server already exists.
Fixed IP configuration	The IP configuration of the device can be permanently assigned manually. However, the device can only be addressed if the assigned IP configuration matches the IP configuration of the PC.

Tab. 2.45 Options for IP configuration

FCT offers a search function (network scan) with which a device can be found in the network without knowledge of the current IP configuration. If the device has been found, the method of the IP configuration can be established with FCT.

- The IP configuration on the device can be changed without the current IP configuration of the device matching the IP configuration of the PC.
- The waving function (flashing of an LED) of the device can be activated and deactivated. With this, a device can be optically identified from a number of devices.

Control via Modbus® TCP

Modbus® TCP is an industrial communication protocol. Modbus®/TCP can be used as an Ethernet-based fieldbus for decentralised I/O systems. The Modbus® communication requires building a TCP connection between a Modbus® client (PC, controller) and the Modbus® server (EMCA). The client creates a connection with the server. The server waits for an incoming connection from the client. As soon as a connection is created, the server answers the requests of the client until the client closes the connection.

The following Modbus® transactions are supported:

Modbus® transactions	Function code
Read Holding Registers	0x03
Read Exception Status	0x07
Write Multiple Registers	0x10
Read/Write Multiple Registers	0x17
Read Device Identification	0x2B

Tab. 2.46 Modbus® transactions

Parameters	Value
Device profile	FHPP with FHPP+ and FPC
TCP-Port:	502 (Default)
Time-out	The TCP/IP-protocol registers failures typically after a few seconds. Through specification of a time in the FCT, an adapted time-out monitoring can be activated for communication on the bus. Value = 0: no special time-out monitoring Value ≠ 0: Time-out monitoring is activated with the specified time (in milliseconds).

Tab. 2.47 Modbus® TCP parameters

Additional information for control via Modbus® → description GDCE-EMCA-EC-C-HP...

2.7.2 STO interface [X6]

The STO interface [X6] permits the 2-channel shut-down of the motor torque (function “securely switched-off torque” (Safe torque off/STO)).



The safety function STO (Safe torque off) is described in detail in the document GDCE-EMCA-EC-S1-... . The safety function STO should only be used in the manner described in this document. Additional information → description of STO safety function, GDCE-EMCA-EC-S1-....

2.7.3 Functions of the base inputs/outputs

The functions of the basic inputs/outputs are dependent on the selected control interface.

Functions of the digital base inputs (6)			
Pin	Name	Control interface	
		I/O interface	Modbus® TCP
[X6.4]	STO 1 (Safe torque off channel 1)	Control port STO channel 1 (→ description of safety functions STO, GDCE-EMCA-EC-S1-...)	
[X6.5]	STO 2 (Safe torque off channel 2)	Control port STO channel 2 (→ description of safety functions STO, GDCE-EMCA-EC-S1-...)	
[X7.2]	Switch 1	Input for reference switch or end switch 1 With the configured edge of switch 1, reaching of the reference/end position is signaled. ¹⁾	
[X8.2]	Switch 2	Input for reference switch or limit switch 2 With the configured edge of switch 2, reaching of the reference/end position is signaled. ¹⁾	
[X9.16]	Control enable/ Acknowledge error	<ul style="list-style-type: none"> – High level: Permit controller enable over the interface that has master control (→ chapter 2.8.3) – Rising edge: acknowledge error message (→ chapter 2.8.4) – Low level: Block controller; causes the controlled braking with the parameterised quick-stop deceleration (→ chapter 2.8.3). 	<p>The input is only evaluated if the enable logic “DIN + control” is parameterised (→ Tab. 2.50).</p> <ul style="list-style-type: none"> – High level: Permit controller enable over the interface that has master control (→ Fig. 2.18). – Low level: Block controller; causes the controlled braking with the parameterised quick-stop deceleration (→ Fig. 2.18).
[9.17]	Sample	Do not connect	Signal for storing the actual position (ad hoc measurement) The current actual position of the drive is saved with an edge change.

¹⁾ Switch function (reference switch or limit switch) and switch type (normally closed or normally open) are configurable with FCT.

Tab. 2.48 Functions of the digital base inputs – connections [X6], [X7], [X8] and [X9]

Functions of the digital base outputs (2)					
Pin	Name	Control interface			
		I/O interface	Modbus® TCP		
[X9.7]	Ready	Signals the ready status of the device <ul style="list-style-type: none"> – High level: Device is ready (ready for operation/no error); the output delivers high level as long as all of the following conditions are met: <table border="1" style="width: 100%; border-collapse: collapse;"> <tr> <td style="width: 50%; padding: 5px;"> <ul style="list-style-type: none"> – At the input “Control enable/Acknowledge error” high level is present. – If the parameterisation interface has master control: The controller enable over the parameterisation interface is present. – At the input “Stop” high level is present. – No error message is present. </td> <td style="width: 50%; padding: 5px;"> <ul style="list-style-type: none"> – Controller enable is present over the interface with master control.¹⁾ – No error message is present. </td> </tr> </table> – Low level: The device is not ready, because one of the following 2 reasons applies: <ul style="list-style-type: none"> – At least one condition is not fulfilled (e.g. when an error is present). – A record has been interrupted (intermediate stop). The record can be continued, or the remaining path can be deleted. 		<ul style="list-style-type: none"> – At the input “Control enable/Acknowledge error” high level is present. – If the parameterisation interface has master control: The controller enable over the parameterisation interface is present. – At the input “Stop” high level is present. – No error message is present. 	<ul style="list-style-type: none"> – Controller enable is present over the interface with master control.¹⁾ – No error message is present.
<ul style="list-style-type: none"> – At the input “Control enable/Acknowledge error” high level is present. – If the parameterisation interface has master control: The controller enable over the parameterisation interface is present. – At the input “Stop” high level is present. – No error message is present. 	<ul style="list-style-type: none"> – Controller enable is present over the interface with master control.¹⁾ – No error message is present. 				
[X9.8]	configurable	Output behaviour configurable with FCT: depictable signals → Tab. 2.52			

1) → Description for the device profile FHPP and Help for the EMCA plug-in.

Tab. 2.49 Functions of the digital base outputs – connection [X9]

Release logic of controller enable with control via the I/O interface

If the I/O interface has master control, the controller enable is requested solely via the input “Control enable/Acknowledge error”.

If FCT or the Web server has master control, the enable signal at the input “Control enable/Acknowledge error” must be present before the controller enable can be requested by the Ethernet interface. In case of transfer of master control through FCT, the current enable signal of the control interface is taken over.

Release logic of controller enable with control via Modbus® TCP

Controller enable takes place over the connection that has master control (➔ chap. 5.4).

Depending on the parameterisation of the enable logic, activation in addition to the controller enable must take place over the digital input Control enable.

Enable logic ¹⁾	Request of controller enable
Control	Controller enable is requested over the interface that has master control (➔ chap. 5.4). The digital input Control enable is not evaluated. If the enable signal is present, the controller is enabled and the drive held in its position.
DIN + controller	Controller enable is requested over the interface that has master control and over the digital input Control enable (DIN Control enable): <ul style="list-style-type: none"> – With FCT, the enable signal must first be present at the input so that the software can carry out the enable. – For FHPP, both signals are on an equal footing. The signal last set requests controller enable. If both signals are present, the controller is enabled and the drive held in its position.

1) Parameterisation of the enable logic takes place under FCT [Controller].

Tab. 2.50 Enable logic

Behaviour with controller enable

If controller enable is present, the controller is enabled and the position controller activated (actual position = setpoint position).

Removal of controller enable

Removal of the controller enable stops the ongoing order (quick stop). If the search speed $v=0$, the “Ready” signal is reset and the controller blocked. For product designs without a holding brake, the drive is then freely movable.

Achieving ready status with control via Modbus® TCP

The ready status is achieved if the following requirements are met:

- Input signals STO 1 and STO 2 (24 V) at [X6.4/5]
- Input signal Control enable at [X9.16] with enable logic “DIN + control interface”
- Controller enabled via the connection that has master control (e.g. FHPP, FCT)
- No error

If all requirements are met, the Ready output is set.

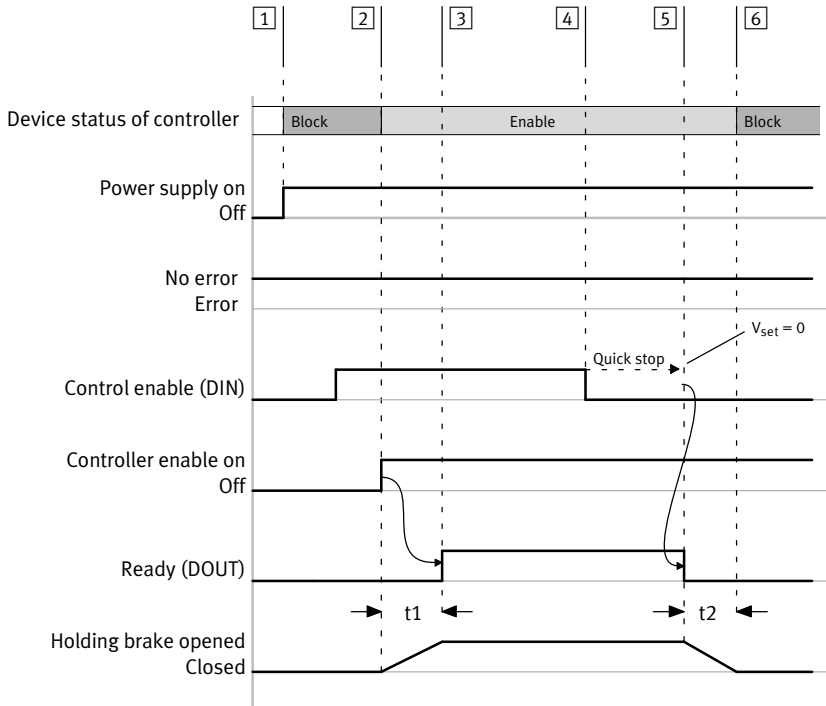

Delay times:

t1: Depending on the parameterised switch-on delay

t2: Depending on the parameterised switch-off delay

- | | | | |
|---|----------------------------|---|---------------------------------------|
| 1 | Switch on the power supply | 4 | Revoke controller enable (quick stop) |
| 2 | Request controller enable | 5 | Holding brake is closed |
| 3 | Ready to operate | 6 | Controller disabled |

Fig. 2.18 Time diagram for achieving ready status – enable logic: controller + DIN

For devices with holding brake (only EMCA-EC-...-...-B):

Control of the holding brake is coupled to the controller enable (➔ chapter 2.4.9):

- When the controller is enabled, the holding brake is released.
- With removal of controller enable, the holding brake is closed.

For control via Modbus[®] TCP, the holding brake in this status can be opened through the “Brake” signal via the control interface, e.g. to move the drive manually (➔ description of the FHPP device profile).

Flying measurement (only for control via Modbus[®] TCP)

If flying measurement is active, the current position value (actual position) is saved with an edge change at the “Sample” input. The device has one separate memory each for falling and rising flanks. The memory can be read via the fieldbus through a higher-order controller.



For information on reading out the measured positions ➔ description for the respective device profile FHPP, GDCE-EMCA-EC-HP...

For the “Sample” input, the following function types can be parameterised:

Function types	Description
Deactivated (Deactivated)	The “Sample” input is inactive (flying measurement is inactive).
After the read-out (After read out)	After an edge change, the position values remain saved until they have been read out (by fieldbus). All additional signal edges are ignored before the read-out. Only after the read-out can a new value be saved through an edge change.
Immediately (Immediately)	Position values are saved at each edge change. Unread values are overwritten.

Tab. 2.51 Function types of the “Sample” input

There is a delay time of typically 8.4 µs between the flying measurement (signal edge) until provision of the measured value. In this time, in a read access to the result register, the old value might still be returned.

Freely configurable digital output

The freely configurable digital output [X9.8] can depict one of the following signals:

Group	Function	Output delivers ...
–	Output high	... always high level.
	Output low	... always low level.
Motion (Motion)	Motion Complete (actual value)	... High level, if the actual value of the current record is in the time window.
	Motion Complete (setpoint value)	... High level, if the setpoint value of the current record is in the time window.
	Axis In motion	... High level, if the axis moves.
	Constant speed reached	... High level, if the target speed or maximum speed of the current record is reached.
	Force limit reached	... High level, if the force limit specified in the record has been reached.
	Standstill monitoring	... High level, if the “Standstill monitoring” message is active.
Homing (Homing)	Homing active	... High level, if homing is being carried out.
	Homing position valid	... High level, if reference position is valid.
Comparators (Comparators)	Position comparator	... High level, if the corresponding comparator is active. ¹⁾
	Speed comparator	
	Force comparator	
	Time comparator	
Faults/ Warnings (Errors/ Warnings)	Common error (low active)	... Low level, if at least one error is reported.
	Following error	... High level, if the corresponding message is active. ²⁾
	I ² t Error	
	I ² t warning	
	Load overvoltage	
	Load undervoltage	

1) Detailed information on comparators → chapter 2.6.2.

2) Information on protective functions → chapter 2.6.3.

Tab. 2.52 Functions of the freely configurable digital output

2.7.4 Functions of the additional inputs/outputs

The EMCA-...-DIO has additional digital inputs (DIN) and outputs (DOUT) at the connection [X9]. If Modbus® TCP is set as the control interface, the additional inputs/output have no function. If the I/O interface is set as the control interface, the functions of these inputs/outputs depend on the selected mode. The mode can be selected by the digital input “Control mode 0/1” (→ chapter 2.8.2).

Overview: Additional inputs (10)			
Pin	Control via the I/O interface		Control via Modbus® TCP
	Mode 0 Normal operation (record selection)	Mode 1 Jog/teach	
[X9.12]	Control mode 0/1 = 0		No Function
[X9.1]	Record selection 1		
[X9.2]	Record selection 2		
[X9.3]	Record selection 4		
[X9.4]	Record selection 8		
[X9.5]	Record selection 16		
[X9.6]	Record selection 32	Jog+	
[X9.13]	Start	Teach	
[X9.14]	Brake control/Delete remaining path	Jog-	
[X9.15]	Stop		
	Control mode 0/1 = 1		

Tab. 2.53 Additional inputs at connection [X9]

Overview: Additional digital outputs (2)			
Pin [X9.x]	Control via the I/O interface		Control via Modbus® TCP
	Mode 0 Normal operation (record selection)	Mode 1 Jog/teach	
[X9.10]	Acknowledge	Setpoint Acknowledge	No Function
[X9.11]	Motion Complete		

Tab. 2.54 Additional outputs at connection [X9]

Functions of the additional inputs/outputs in normal operation (mode 0)		
Pin	Name	Function
Inputs		
[X9.12]	Control mode 0/1	Low level: Activate mode 0 (normal operation).
[X9.1] ... [X9.6]	Record selection 1 ... 32	Selection of the record number (binary coded). 64 records (record 0 to 63) can be selected via these 6 inputs. Record 0 is reserved for homing.
[X9.13]	Start	Rising edge: Start or continue the record
[X9.14]	Brake control/Delete remaining path	<ul style="list-style-type: none"> – High level: <ul style="list-style-type: none"> – If the controller enable is not present: Release the holding brake. – If the controller enable is present: Delete the remaining path. – Low level: Automatic activation of the holding brake
[X9.15]	Stop	<ul style="list-style-type: none"> – High level: No stop/intermediate stop – Low level: Stop the drive with the parameterised deceleration of the active position record (stop/intermediate stop)
Outputs		
[X9.10]	Acknowledge	Handshake signal for the start signal [X9.13]: <ul style="list-style-type: none"> – Falling edge: Job accepted – Rising edge: reaction to falling edge of the start signal
[X9.11]	Motion Complete	Signals the end of the processing of a job (target recognition) <ul style="list-style-type: none"> – High level: job finished – Low level: job in progress

Tab. 2.55 Function overview of normal operation (mode 0)

Record selection in normal operation (mode 0)						
Record selection 1 ... 32						
... 32 (2⁵)	... 16 (2⁴)	... 8 (2³)	... 4 (2²)	... 2 (2¹)	... 1 (2⁰)	Record number
0	0	0	0	0	0	0 ¹⁾
0	0	0	0	0	1	1
0	0	0	0	1	0	2
0
0	1	1	1	1	1	31
...						...
1	1	1	1	1	0	62
1	1	1	1	1	1	63

1) Homing (Homing)

Tab. 2.56 Binary coding of the record numbers in mode 0 (normal operation)

Functions of the additional inputs/outputs in jog/teach mode (mode 1)		
Pin	Name	Function
Inputs		
[X9.12]	Control mode 0/1	High level: Activate mode 1 (jog/teach).
[X9.1] ...	Record selection 1 ... 16	Selection of the record number (binary coded). 31 records (record 1 to 31) can be selected via these 5 inputs.
[X9.5]		
[X9.6]	Jog+	<ul style="list-style-type: none"> – Rising edge: Jogging in positive direction starts at crawl speed. – High level: After the end of the crawl period, the drive continues at jog speed. – Falling edge: Stop jogging
[X9.13]	Teach	<ul style="list-style-type: none"> – Rising edge: Start teaching process for the selected position record (acknowledgement → acknowledge teaching [X 9.10]). – Falling edge: Adopt current position for the selected position record (acknowledgement → acknowledge teaching [X 9.10]).
[X9.14]	Jog–	<ul style="list-style-type: none"> – Rising edge: Jogging in negative direction starts at crawl speed. – High level: After the end of the crawl period, the drive continues at jog speed. – Falling edge: Stop jogging
[X9.15]	Stop	<ul style="list-style-type: none"> – High level: No stopping – Low level: Stop the drive with the parameterised deceleration
Outputs		
[X9.10]	Setpoint Acknowledge	Handshake signal for the teach signal [X9.13]: <ul style="list-style-type: none"> – Rising edge: Ready for teaching – Falling edge: Value accepted
[X9.11]	Motion Complete	Signals the end of the processing of a job (target recognition) <ul style="list-style-type: none"> – High level: job finished – Low level: job in progress

Tab. 2.57 Function overview mode 1

Record selection for jog/teach (mode 1)					
Record selection 1 ... 16					
... 16 (2⁴)	... 8 (2³)	... 4 (2²)	... 2 (2¹)	... 1 (2⁰)	Record number
0	0	0	0	1	1
0	0	0	1	0	2
...					...
1	1	1	1	1	31

Tab. 2.58 Binary coding of the record numbers in mode 1 (jog/teach)

2.8 Control via the I/O interface

2.8.1 Create ready status

The power supply must be switched on for at least 1 s (t_1) before the control signals can be applied at the inputs. The readiness for operation can only be established if there is no error. Errors present must be remedied and acknowledged (→ chapter 2.8.4).

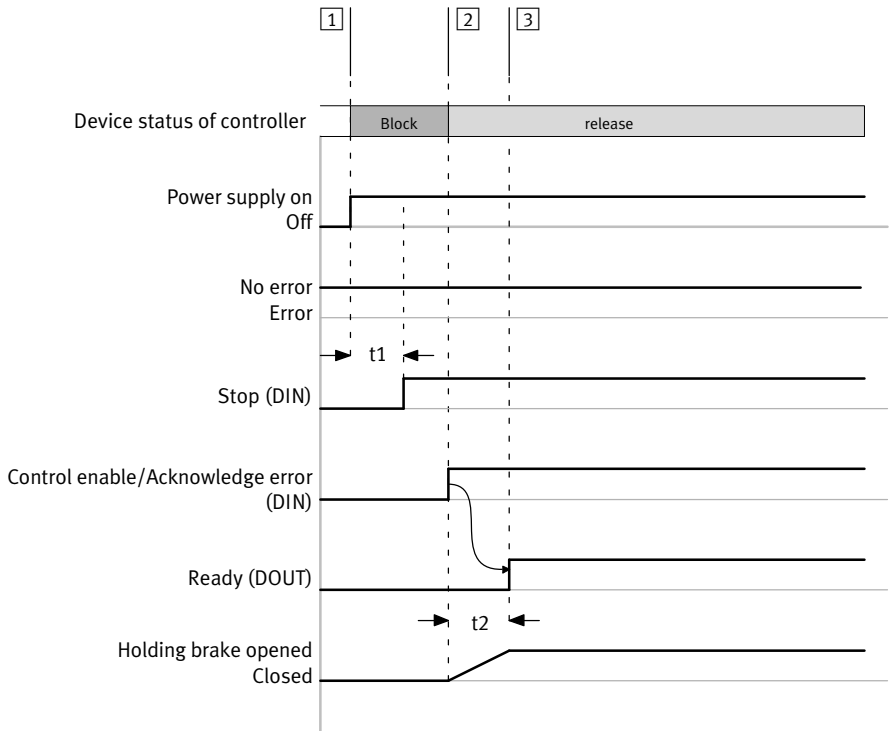

Switch-on time $t_1 \geq 1$ s

Delay times:

t_2 : depending on the parameterised switch-on delay

- 1 Switch on the power supply
- 2 Request controller enable
- 3 Ready to operate

Fig. 2.19 Time diagram, create ready status

2.8.2 Set mode for the I/O interface

The mode for the I/O interface is set by the digital input “Control mode 0/1”:

Pin	Input	Level	Description
[X9.12]	Control mode 0/1	Low level	Mode 0; normal operation
		High level	Mode 1; jog/teach

Tab. 2.59 Control mode of the I/O interface

The control mode should only be set during standstill. If the control mode is set during a job, the current job is stopped first (quick stop). Then it will switch to the set control mode.



To avoid malfunctions during mode changeover, the indicated time delay t must be observed. Then enable the inputs.

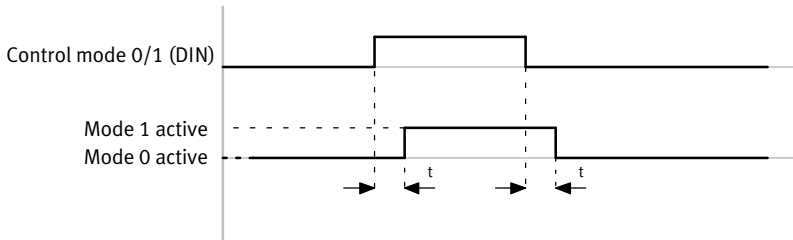

Time delay $t \geq 2$ ms

Fig. 2.20 Set time diagram for the I/O interface mode

2.8.3 Enabling and disabling the controller

The controller enable can be controlled by the input “Control enable/Acknowledge error”.

- High level requests the controller enable.
- Low level blocks the controller. No additional positioning jobs will then be accepted.

For devices with holding brake (only EMCA-EC-...-B):

The control of the holding brake is coupled to the controller enable (➔ chapter 2.4.9).

- When the controller is enabled, the holding brake is released.
- With removal of controller enable, the holding brake is closed.



Further information about the holding brake ➔ chapter 2.4.9 and chapter 2.8.11.

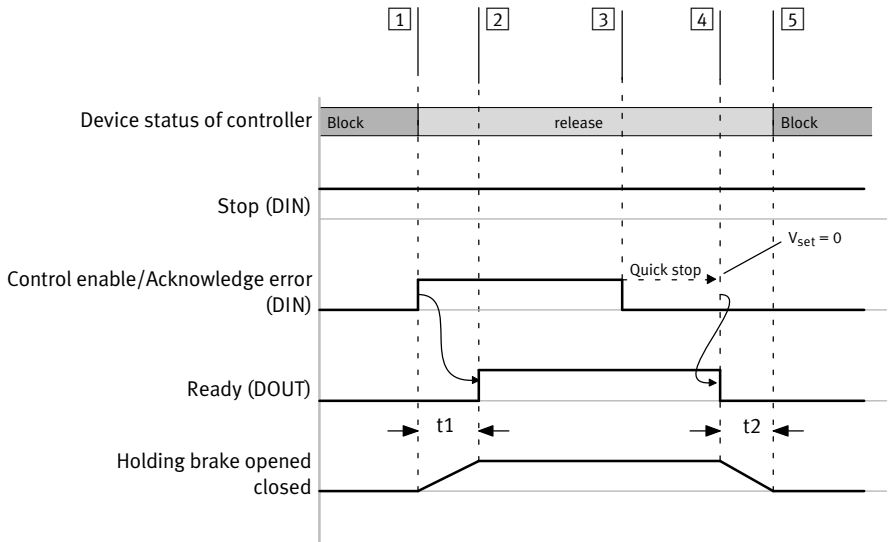

Delay times:

t1: Depending on the parameterised switch-on delay

t2: Depending on the parameterised switch-off delay

- | | |
|---|---|
| 1 Request controller enable | 4 With removal of the controller enable, the holding brake is closed |
| 2 Controller has been enabled | 5 Controller disabled |
| 3 Controlled stop (holding brake released) | |

Fig. 2.21 Time diagram of controller enable after Power ON

2.8.4 Acknowledge error

When an error occurs, the drive switches to error status. The output “Ready” then supplies a low signal. The error code can be read out via:

- Festo Configuration Tool (FCT)
- Web server

The reaction of the device to the error can be parameterised by the FCT error management in some cases (→ chapter 2.6.4). In some cases, errors can be acknowledged immediately, e. g. in case of a drag error. In other cases, the cause for the error must be remedied first (e. g. temperature error, load voltage error).

Acknowledgeable error messages can be acknowledged as follows:

- with the Festo Configuration Tool (→ FCT online help)
- by a rising edge at the input “Control enable/Acknowledge error”

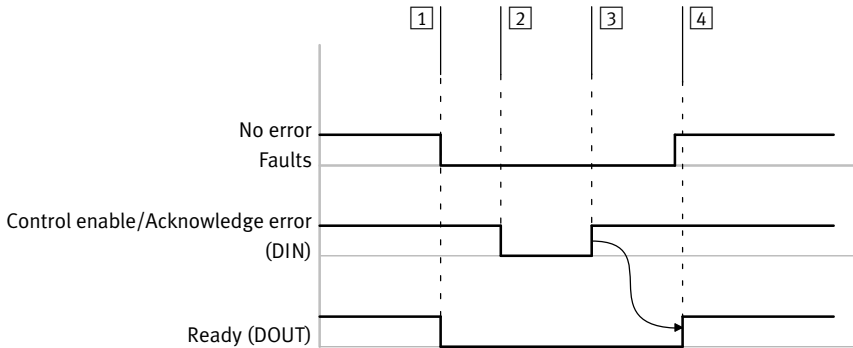

- | | |
|--|---|
| <p>1 Error event</p> <p>2 Revoke controller enable</p> | <p>3 Acknowledge error and request controller enable</p> <p>4 Controller has been enabled</p> |
|--|---|

Fig. 2.22 Time diagram Acknowledge error



If errors cannot be acknowledged, the device must be switched on again (power OFF/ON). Diagnostic events that are parameterised as warnings are displayed once and do not need to be acknowledged.

2.8.5 Carrying out homing

To perform homing, the record number 0 must be addressed at the inputs “Record selection 1...32”. Homing is started by input REF “Start”.

After the successful completion of the homing run, the output “Motion Complete” is set.

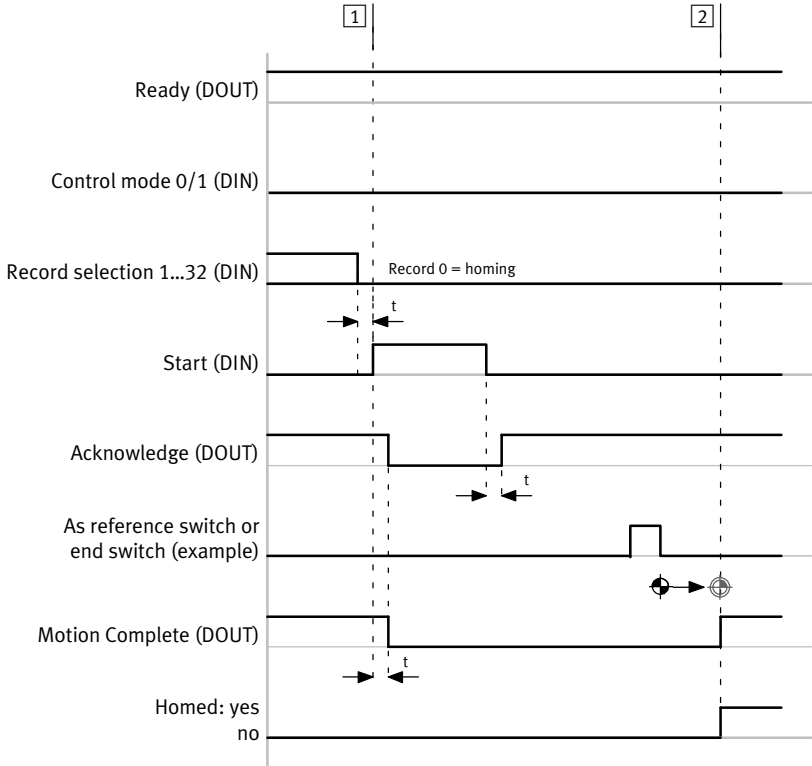

Time delay $t \geq 2$ ms

1 Referenzfahrt starten

2 Drive is referenced

Fig. 2.23 Time diagram mode 0; homing to reference switch or end switch

2.8.6 Jog, teach (mode 1)

In position mode, the target positions for 31 absolute command sets can be taught via the I/O interface.

The teach signals are edge-triggered. If the teach signal was set and the process cannot be executed, the teach signal needs to be reset. A new process cannot be started until after that.

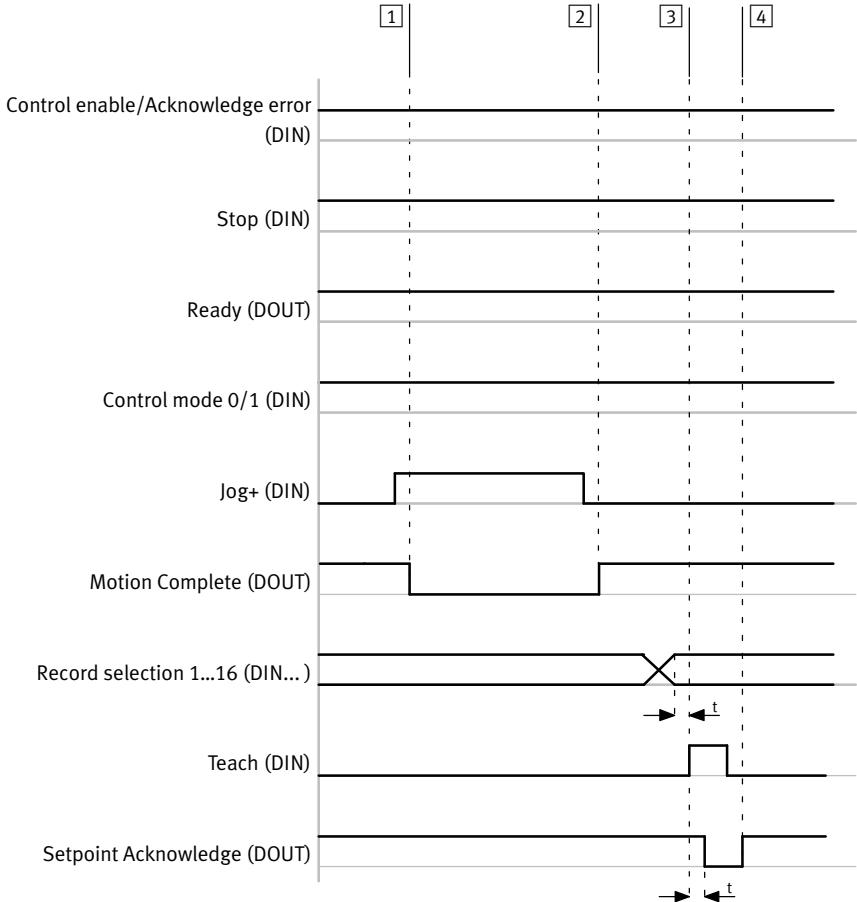

Time delay $t \geq 2$ ms

1 Jogging+ has been started

2 Jogging+ has been stopped

3 Establish teach readiness

4 Current position has been applied

Fig. 2.24 Time diagram jog, teach

2.8.7 Start record (mode 0)

The record number of a job from the record table is transferred to the device as a binary code via the inputs “Record selection 1...32”. Record number 0 is assigned to homing. The record number for a rising edge is adopted at the input “Start”, and the record or the record sequence is processed (depending on parameterisation). The adoption of the job is acknowledged by the signal “Acknowledge”. With the parameter “MC visible”, it is possible to specify for record sequences whether the signal “Motion Complete” should be output between each record (→ chapter 2.5.2). The “Start Condition” parameter (Start Condition) specifies how the device should react to the start signal for the record if another record is still being processed (→ chapter Tab. 2.32). The time diagram shows the time behaviour for the start of a job in mode 0.

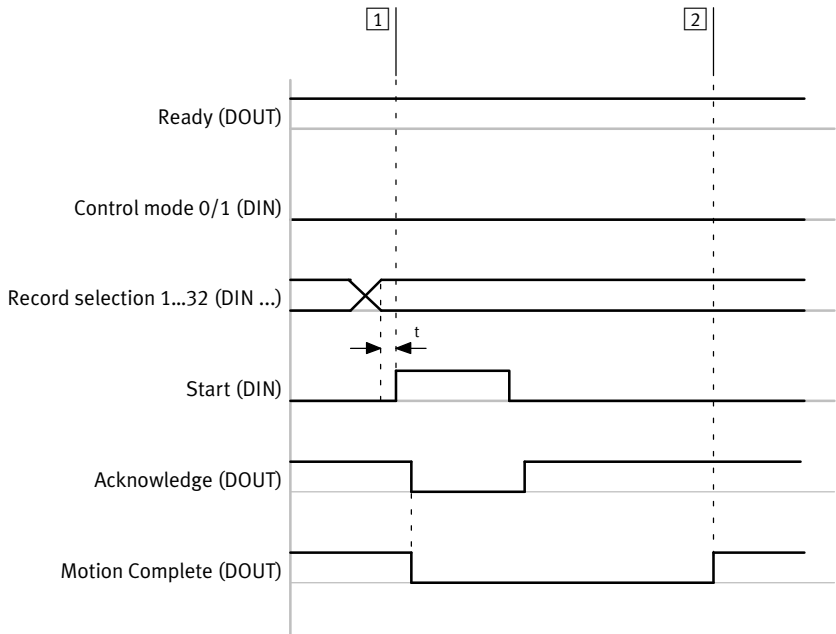

Time delay $t \geq 2$ ms

1 Start record

2 Target recognition (Motion Complete)

Fig. 2.25 Time diagram Start record (mode 0)

2.8.8 Start, stop and continue record (mode 0)

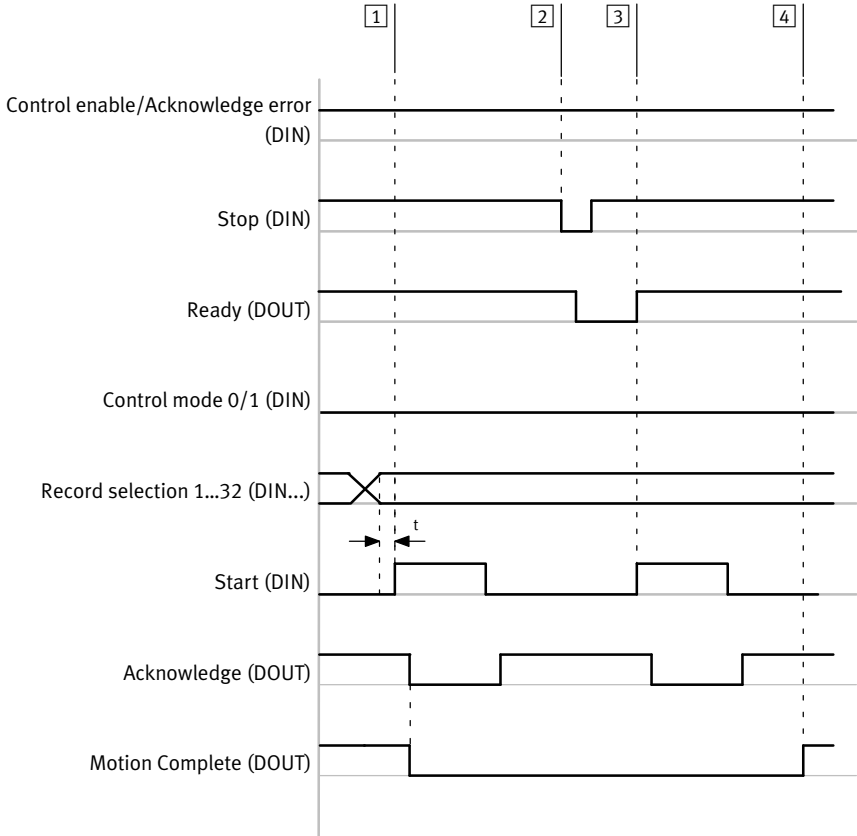

Time delay $t \geq 2$ ms

- | | |
|--|---|
| 1 Start record | 3 Continue record |
| 2 Stop record (intermediate stop) | 4 Target recognition (Motion Complete) |

Fig. 2.26 Start, stop and continue record time diagram

2.8.9 Start and stop record, delete remaining path (mode 0)

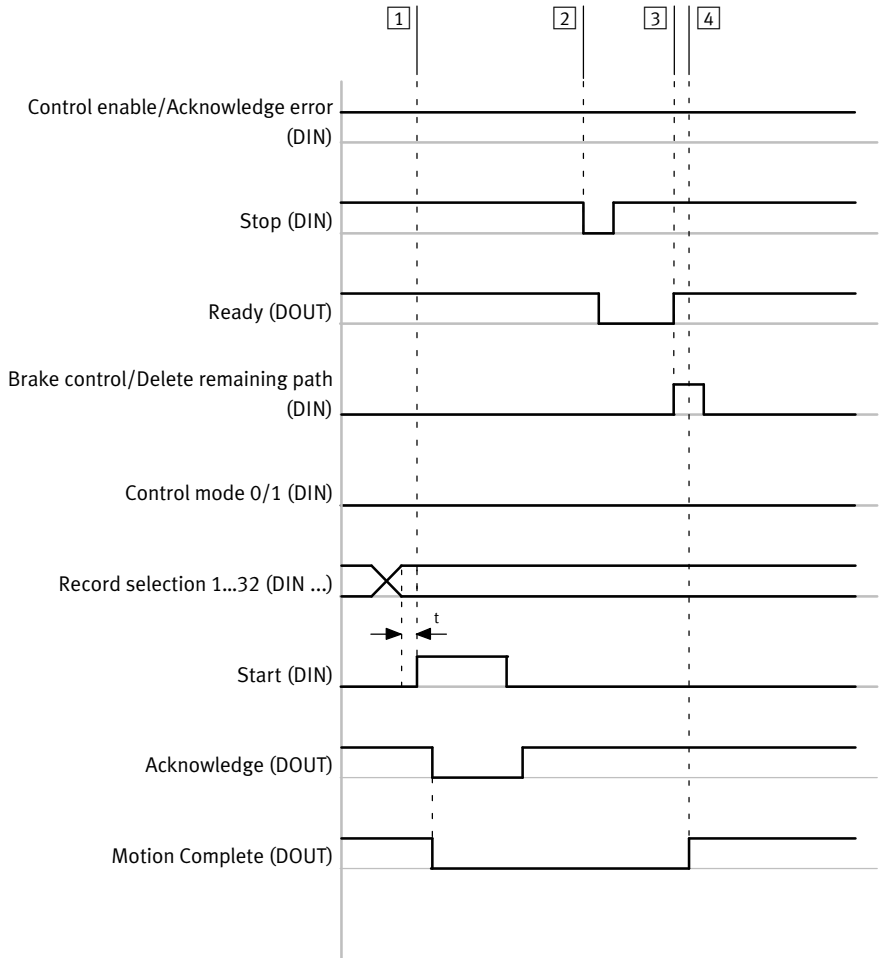

Time delay $t \geq 2$ ms

- | | |
|--|---|
| 1 Start record | 3 Delete remaining path |
| 2 Stop record (intermediate stop) | 4 Job finished (Motion Complete) |

Fig. 2.27 Start, stop record time diagram, delete remaining path

2.8.10 Record switching

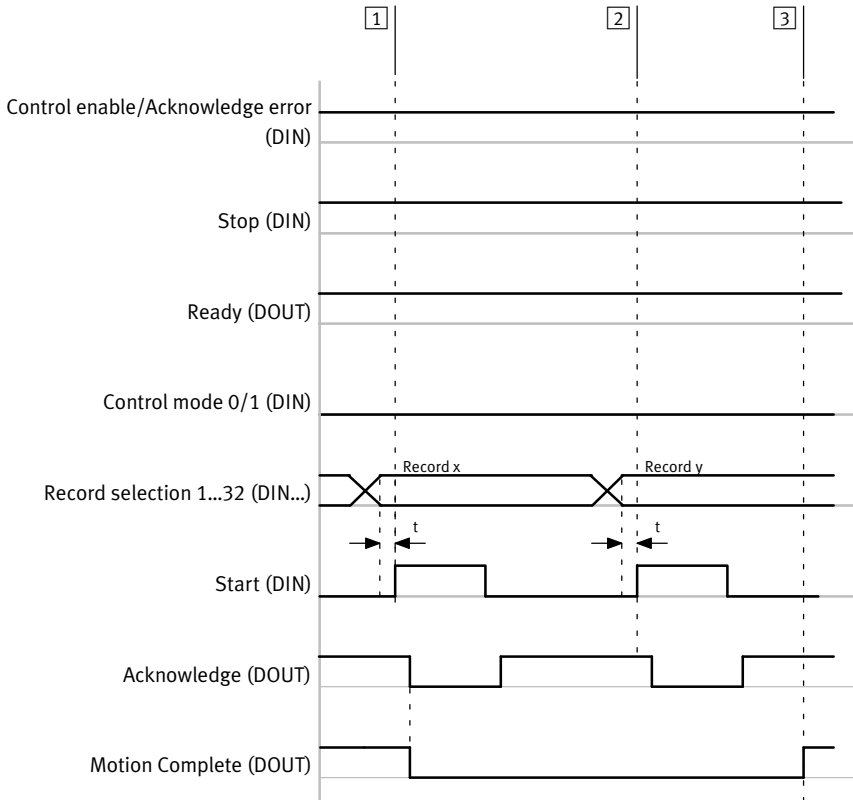

Time delay $t \geq 2$ ms

- 1 Record x start
- 2 Record changeover from record x to record y
Start condition record y: interrupt
- 3 Job finished (record y)

Fig. 2.28 Record changeover with start condition = Interrupt

2.8.11 Release holding brake (only EMCA-EC-...-...-B)

If the controller is blocked, the holding brake is automatically closed. In this status, the holding brake can be opened by the high level at the input “Brake control/Delete remaining path”, e.g. in order to manually shift the drive.

The mechanical inertia of the holding brake means that it takes a certain length of time to release and activate it. The behaviour of the device is adapted to the inertia of the holding brake by parameters (→ chapter 2.4.9).



Further information about the holding brake → Chapter 2.4.9.

3 Mounting

3.1 Dimensions

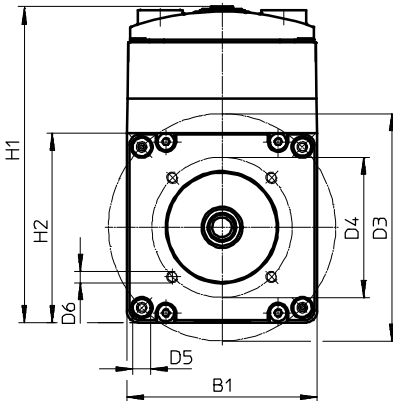
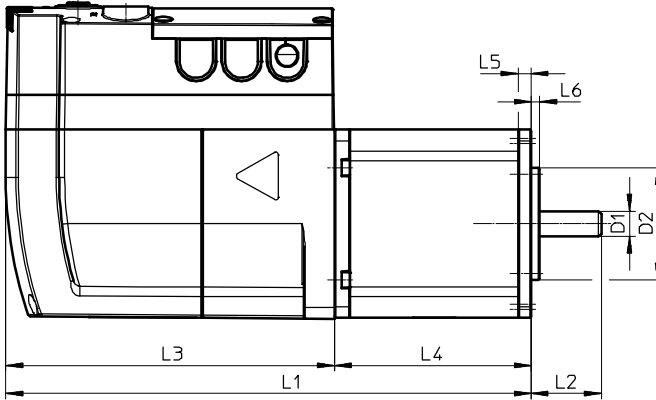

Type	Dimension	L1	L2	L3	L4	L5	L6
EMCA-...-S-...	[mm]	169,9 +0.8/-1.1	25 ±0.5	117,2 -0.3	52,7 ±0.8	4,7 ±0.3	3 -0.1
EMCA-...-M-...		187,4 +0.8/-1.1			70,2 ±0.8		

Dimension	H1	H2	B1	D1	D2	D3	D4	D5	D6
[mm]	113 ±0.5	67	67	∅ 9 -0.009	∅ 40 -0.039	∅ 81 ±0.2	∅ 50 ±0.2	∅ 6.3 ±0.2	M4x5

Tab. 3.1 Dimensions

3.2 Performing mounting



Caution

Uncontrolled drive motion may cause personal injury and material damage.

Before carrying out mounting, installation and maintenance work:

- Switch off power supply.
- Secure the power supplies against accidental reactivation.



The device can become very hot in operation.

- Ensure there is sufficient heat removal, e.g. through a suitable motor flange or the electromechanical drive.
- Make sure there is sufficient ventilation.

The device is mounted with a gearbox or directly onto an axis with axial kits or parallel kits. It can be mounted in any position.



Axial kits, parallel kits and gearbox → www.festo.com/catalogue.

In mounting, the shaft of the drive is connected to the shaft of the axis over a coupling (→ Assembly instructions for axial or parallel kit). The gearbox is mounted directly to the drive. For attachment, the device has a mounting flange. The mounting flange offers the following options for fastening:

- Fastening via 4 through-holes for screws of size M6
- Fastening via 4 female threads of size M4 (screw-in depth [mm]: 5)

Mounting flange EMCA-EC-67-...

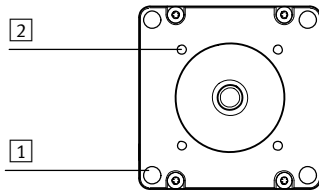

1 Through-holes 6.3 mm (4 x)

2 Thread M4 x 5 (4 x)

Fig. 3.1 Mounting hole pattern of the mounting flange

Before mounting

1. Switch off power supplies.
2. Secure the power supplies against accidental reactivation.
3. Clean the shaft of the drive. The coupling will only grip without slipping on a shaft pin which is dry and free of grease.

Mounting



Note

Excessive axial and radial forces on the motor shaft can damage the motor.

- Comply with maximum permissible shaft loads (→ Technical data for the integrated motor in Appendix A.1.5).



Observe the assembly instructions for the additional components used (e.g. axial kit, parallel kit, gear unit, shaft). Observe the assembly instructions of the lines regarding bending radii or suitability for energy chains.

The drive must be mounted securely and free of tension.

1. Move the slide or cantilever of the driven mechanical system into a safe position.
2. Connect the EMCA to the driven mechanical system (→ Assembly instructions of the additional components used).
3. Tighten the mounting screws (4x). Tightening torque → Assembly instructions of the additional components used.

4 Installation

4.1 Safety instructions



Warning

Danger of electric shock from voltage sources without protective measures.

- Use for the electrical power supply only PELV circuits (Protective extra-low voltage/ PELV) in accordance with EN 60204-1.
- Also observe the general requirements for PELV circuits in accordance with EN 60204-1.
- Use only power sources that guarantee a reliable electric separation of operating and load voltage in accordance with EN 60204-1.



Caution

Uncontrolled drive motion may cause personal injury and material damage.
Before carrying out mounting, installation and maintenance work:

- Switch off power supplies.
- Secure the power supplies against accidental reactivation.



Note

The system contains electrostatically sensitive components. Electrostatic discharges caused by improper handling or incorrect earthing can damage the internal electronics.

- Observe the handling specifications for electrostatically sensitive devices.
- Discharge yourself electrostatically before assembling or disassembling modules to protect the modules.



Note

Material damage due to incorrect handling when detaching the plug connectors.

- Unlock plug connectors on the printed circuit board by pressing the locking lever.
- Pull on the plug housing to pull out the plug connector.



Note

Long signal lines reduce the interference immunity (EMC).

- Observe the maximum permissible branch line lengths (→ Tab. 4.1).



The device can generate high frequency interference, which may make it necessary to implement interference suppression measures in residential areas.

4.2 EMC-compliant wiring



Earth/ground:

- Connect the motor flange to the earth potential with low impedance (short cable with large cross section) if the motor flange is not mounted to an earthed machine frame through an electromechanical drive.
- If a screened supply cable is to be used, place the cable screening on the functional earth connection (flat plug).

Routing cables:

- Comply with general guidelines for EMC-appropriate installation, e.g.:
 - Do not run signal cables parallel to power cables.
 - Comply with required minimum distances between signal cables and power cables dependent on the installation conditions.
 - Avoid crossing power cables or running them at a 90° angle.
- Comply with permissible cable lengths (→ Tab. 4.1).

Connection	Interface	Cable length [m]	Shielding
[X1]	Ethernet interface	Max. 100 ¹⁾	– Screened copper connecting cable, 4-conductor; Ethernet twisted pair cable (→ Tab. 4.4)
[X4]	Power supply	≤ 30	– Unshielded – A screened cable can optionally be used. In this case, the cable screening can be attached to the flat plug on the device side (→ Tab. 4.7).
[X5]	Braking resistor	≤ 3	– Unshielded
[X6]	STO interface	≤ 30	
[X7]	End/reference switch	≤ 3	
[X8]			
[X9]	I/O interface	≤ 30	
[X10]	External battery	≤ 3	

1) Between the network participants

Tab. 4.1 Information for EMC-compliant wiring

4.3 Ethernet interface [X1]

The Ethernet interface on the top of the connection box permits connection to a PC or a network.

➔ Note

Unauthorised access to the device can cause damage or malfunctions. When connecting the device to a network:

- Protect the network against unauthorised access.

Measures to protect the network include:

- Firewall
- Intrusion Prevention System (IPS)
- Network segmentation
- Virtual LAN (VLAN)
- Virtual Private Network (VPN)
- Safety at physical access level (Port Security)

For additional information ➔ guidelines and standards for security in information technology, e.g. IEC 62443, ISO/IEC 27001.

Connection	Design
[X1] on the device	M12 socket, 5-pin, D-coded
Counterplug	Plug M12, 4- or 5-pin, D-coded

Tab. 4.2 Design of the connection [X1]

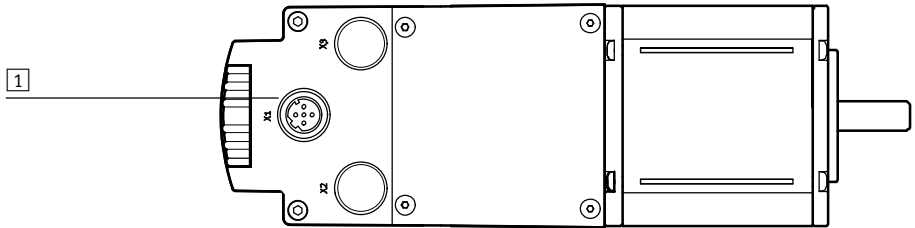

1 Ethernet interface [X1]

[X1]	Pin	Designation	Description
	1	TD+	Transmitted data +
	2	RD+	Received data -
	3	TD-	Transmitted data -
	4	RD-	Received data -
	5	-	Not connected
Housing		Shield/FE	Shield/functional earth

Tab. 4.3 Ethernet interface connection [X1]

Connecting the Ethernet interface



Recommendation: Use the connecting cable NEBC-D12G4-... from Festo.

- Connect the EMCA to your network or directly to the PC via a hub/switch. Note cable specification.

Characteristics		Cable specification
Cable type		Ethernet twisted pair cable, shielded (shielded twisted pair/STP)
Transmission class		Category Cat 5 or higher
Cable diameter	[mm]	> 6
Wire cross-section	[mm ²]	0.14 ... 0.75 (22 AWG) ¹⁾
Connection length	[m]	Max. 100

1) Required for max. connection length between network participants: 22 AWG

Tab. 4.4 Cable specification for the Ethernet interface [X1]

4.4 Connection of the plug connectors [X4] ... [X10]

The connections [X4] to [X10] are designed as plug connectors and are located inside the connection box. The following table provides an overview of the respective cable specifications.

Overview of cable specifications ¹⁾²⁾						
Connection	[X4]	[X5]	[X6]	[X7], [X8]	[X9]	[X10]
	Power supply	Braking resistor	STO (Safe torque off)	End/reference switch	I/O interface	External battery
Manufacturer ³⁾	JST		Tyco Electronics AMP			JST
Plug connector	B2P-VH-FB-B-C	B2P-VH-FB-B	3-794636-6	2-1445053-3	4-794636-8	B2B-ZR-SM4-TF
Counterplug	VHR-2N-BK (Black)	VHR-2N (white)	794617-6	1445022-3	1-794617-8	ZHR-2
Crimp contact	SVH-41T-P1.1		AWG24 ... AWG20: – 794606-1 (strips) – 794610-1 (loose) AWG30 ... AWG26: – 794607-1 (strips) – 794611-1 (loose)			SZH-002T-P0,5
Crimp pliers	WC-930 or YC-930R		91501-1 (AWG24 ... AWG20) 91502-1 (AWG30 ... AWG26)			YRS-491, WC-491 or WC-ZH2632
Strip length	Observe current specifications/crimp instructions of the manufacturer of the plug connectors!					
Diameter of the cable insulation sheath [mm]	1.7 ... 3		0.89 ... 1.53			0.8 ... 1.1
Wire cross-section [mm ²]	0.5 ... 1.25 (AWG20 ... AWG16)		0.2 ... 0.5 (AWG24 ... AWG20) 0.05 ... 0.12 (AWG30 ... AWG26)			0.08 ... 0.13 (AWG28 ... AWG26)
Cable outside diameter	Seal elements for the following cable diameters are included in the scope of delivery: 2.9 ... 3.0 mm, 6.5 ... 7.1 mm, 9.1 ... 9.6 mm					
Cable type	Unshielded ⁴⁾		Unshielded			

1) Includes specifications of manufacturers of plug connectors and crimp contacts at the time the document was released

2) Observe current specifications/crimp instructions of the named manufacturers!

3) Manufacturer of the plug connectors, counterplugs and crimp contacts

4) Optional: screened (→ Tab. 4.1)

Tab. 4.5 Overview of cable specifications

Connecting cables



When making the connecting cables, observe the current specifications/crimp instructions of the named manufacturers (→ Tab. 4.5).



Recommendation: Use the connecting cable NEBM-... from Festo (→ www.festo.com/catalogue).

Make all required connecting cables before connecting the plug connectors.

1. Strip cable ends and attach crimp contacts (→ Crimp instructions/specifications of the respective manufacturers).
2. Push cable ends with crimp contacts into the correct plug connector until the cable ends engage correctly (pin allocation → Chapter 4.4.1 to 4.4.5).

The cable throughfeeds are located on 2 sides of the connection box. The lines can thus be brought through on 2 sides – dependent on the local space conditions. Seal inserts are required for each cable throughfeed to ensure the IP degree of protection (→ Fig. 4.1, 1).

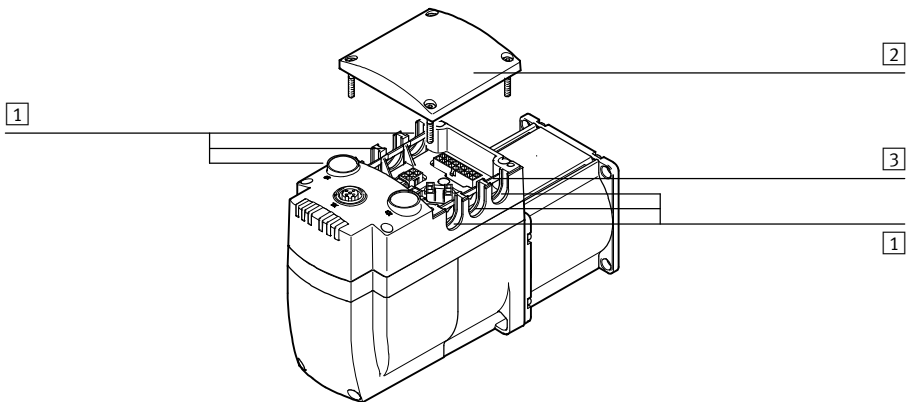

- | | |
|--|--|
| 1 Cable throughfeed (1 seal insert per cable throughfeed required) | 2 Cover of the connection box |
| | 3 Plastic ridge (1x per cable throughfeed) |

Fig. 4.1 Cable throughfeeds of the connection box

A seal insert assortment with the following seal inserts is part of the scope of delivery:

- Blind seals
- Seal inserts for lines with outside diameter 2.9 ... 3.1 mm
- Seal inserts for lines with outside diameter 6.1 ... 7.1 mm
- Seal inserts for lines with outside diameter 8.5 ... 9.6 mm

The seal insert assortment is also available as an accessory (→ www.festo.com/catalogue).

Connecting the internal plug connectors

For electrical installation, the cover of the connection box must be dismantled.

Before dismantling the cover:

1. Switch off the power supply.
2. Protect the device against being switched on again.



Note

The EMCA contains electrostatically sensitive devices. Electrostatic discharges caused by improper handling or incorrect earthing can damage the internal electronics.

- Observe the handling specifications for electrostatically sensitive devices.
- Discharge yourself electrostatically before assembling or disassembling modules to protect the modules.



For electrical installation:

When mounting seal inserts and the cover, make sure the seals are clean.

1. If the cover of the connection box is already mounted, loosen the cover with an Allen key (width across flats (SW) 2.5 mm) and carefully remove the cover.
2. Place seal inserts around the line.
3. With pliers, break out plastic ridges of the cable throughfeeds (→ Fig. 4.1, [3](#)).
4. Push line with seal insert into the respective cable throughfeed – depending on the space conditions.
5. Connect lines correctly (pin allocation → Chapter 4.4.1 to 4.4.5).
6. Push in all plug connectors until the plugs engage.
 - To release plug connectors on the printed circuit board:
 - Unlock plug connectors by pressing the locking lever and pull them out on the plug housing.
7. Seal unused cable throughfeeds with blind seals.
8. Position cover of the connection box correctly. Make sure the seal is seated correctly.
9. Tighten the cover with the 4 included screws – tightening torque 1.5 Nm.

4.4.1 Power supply [X4]



Warning

Danger of electric shock from voltage sources without protective measures.

- Use for the electrical power supply only PELV circuits (Protective extra-low voltage/ PELV) in accordance with EN 60204-1.
- Also observe the general requirements for PELV circuits in accordance with EN 60204-1.
- Use only power sources that guarantee a reliable electric separation of operating and load voltage in accordance with EN 60204-1.

Through the use of PELV circuits, protection from electric shock (protection from direct and indirect contact) in accordance with EN 60204-1 is ensured (Electrical equipment of machines. General requirements). A 24 V power supply unit used in the system must satisfy the requirements of EN 60204-1 for DC power supply (behaviour during power interruptions, etc.).

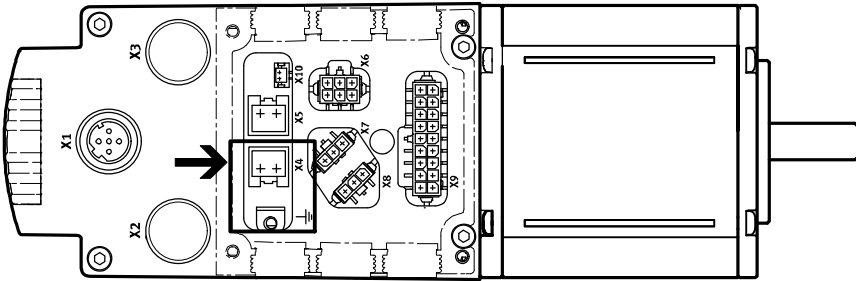

[X4]	Pin	Description
	1	+24 V DC Power supply (logic and load voltage) 19.2 V DC ... 28.8 V DC
	2	0 V GND, reference potential

Tab. 4.6 Pin allocation of power supply [X4]

If a screened supply cable is used, the cable screening can be placed on the functional earth connection (flat plug).

Flat pin	Pin	Description
	- FE 	Optional connection for the cable screening if a screened supply cable is to be used Counterplug: flat connector sleeve (6.3 x 0.8 mm ²)

Tab. 4.7 Flat plug (FE) – optional

Connection to the supply voltage

- Before establishing the connection make sure the power supply is switched off.

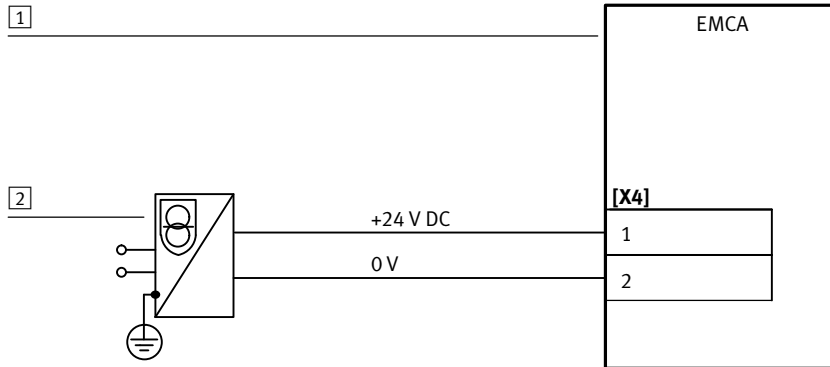

1 Integrated drive EMCA

2 Power supply unit 24 V DC

Fig. 4.2 Connection to the supply voltage

4.4.2 Braking resistor [X5]

The drive of the EMCA supplies energy back into the intermediate circuit of the device during braking or with independent excitation. Excess energy must be absorbed by a braking resistor, which must be attached externally, and converted into heat energy to avoid impermissibly high voltages. An internal braking resistor is **not** present (→ Tab. 2.41).



Note

Impermissibly high voltages can result from feeding energy back into the intermediate circuit of the device. This can damage the device and cause malfunctions.

- Connect a braking resistor adapted to the braking output that occurs in the desired application.

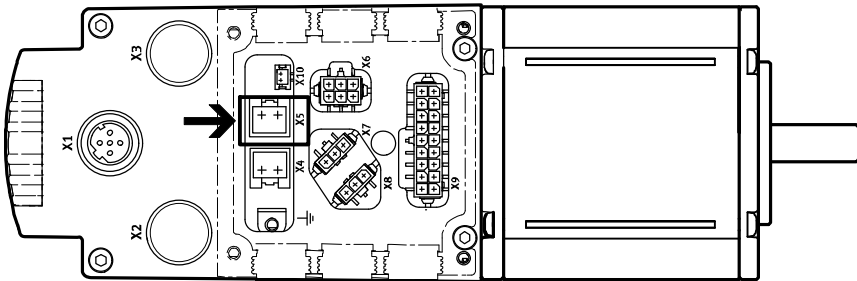

[X5]	Pin	Description	
	1	ZK+	Connection for the external braking resistor R_{BR} 6 Ω
	2	BR-CH	

Tab. 4.8 Pin allocation for braking resistor [X5]



The braking resistor CACR-LE2-6-W60 from Festo is suitable (6 Ω /60 W).

4.4.3 **STO interface [X6]**



The safety function STO (Safe torque off) is described in detail in the document GDCE-EMCA-EC-S1-.... The safety function STO should only be used in the manner described in this document.

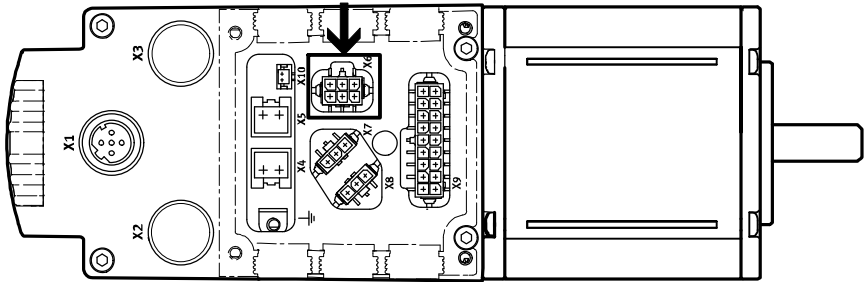

[X6]	Pin	Designation	Description
	1	NC1	Acknowledgment contact: – Potential-free – Low impedance if the STO function has been requested and activated via two channels.
	2	NC2	
	3	+24 V DC LOGIC OUT	Logic voltage output (from [X4]), reference potential (0 V) is pin [X6.6] or [X4.2] (internally bridged) Not overload-proof! Max. 100 mA permissible.
	4	STO 1	Control ports for STO function ¹⁾
	5	STO 2	
	6	GND	Reference potential 0 V

1) In the web server, assigned to the Basic IO Interface (→ Web server).

Tab. 4.9 Pin assignment of STO interface (Safe torque off) [X6]

4.4.4 Limit or reference switch [X7], [X8]

The connections [X7] and [X8] permit connection of 3-pin limit or reference switch (➔ Tab. 4.10 and Tab. 4.11). As a result, each device can connect to a maximum of 2 limit switches or 1 limit switch and 1 reference switch.

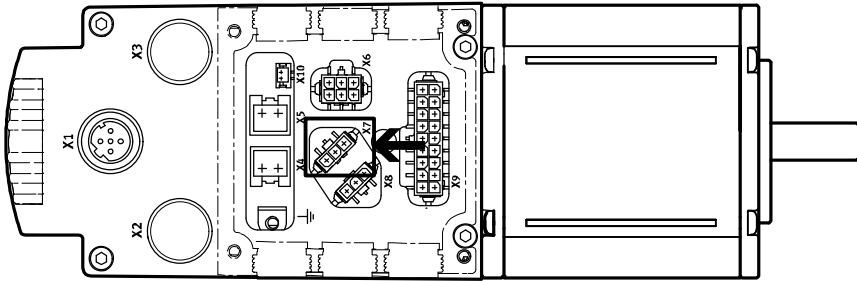

[X7]	Pin	Description
	1	+24 V DC Voltage output 24 V for supply of the reference or limit switch 1 (configurable with FCT, not short-circuit safe)
	2	Switch 1 Signal input for reference switch or limit switch 1
	3	GND Reference potential 0 V

Tab. 4.10 Pin allocation of reference or limit switch 1 [X7]

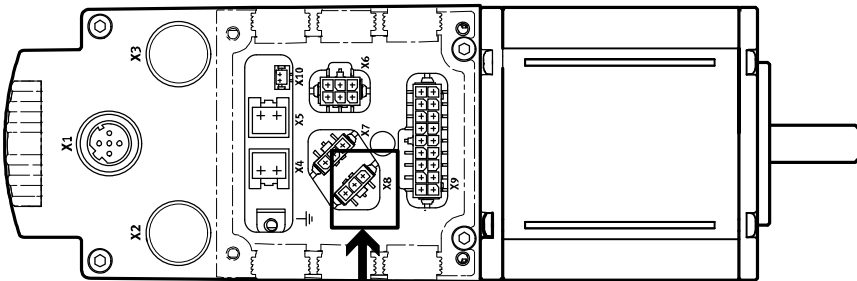

[X8]	Pin	Description
	1	+24 V DC Voltage output 24 V for supply of the reference or limit switch 2 (configurable with FCT, not short-circuit safe)
	2	Switch 2 Signal input for reference switch or limit switch 2
	3	GND Reference potential 0 V

Tab. 4.11 Pin allocation of reference or limit switch 2 [X8]

4.4.5 I/O interface [X9]

The remaining digital I/Os are brought together on connection [X9].

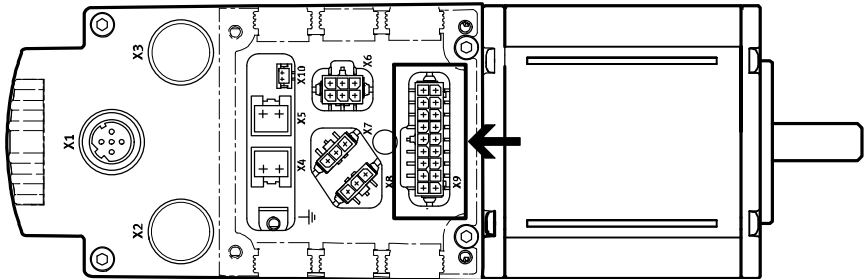

[X9]	Pin	Type ¹⁾	Control interface		Modbus® TCP
			I/O interface Mode 0	Mode 1	
	1	DIN	Record selection 1		No Function
	2	DIN	Record selection 2		
	3	DIN	Record selection 4		
	4	DIN	Record selection 8		
	5	DIN	Record selection 16		
	6	DIN	Record selection 32	Jog+	
	7	DOUT	Ready		
	8	DOUT	configurable		
	9	-	Output 24 V DC, looped through from [X4.1]		
	10	DOUT	Acknowledge	Setpoint Acknowledge	No Function
	11	DOUT	Motion Complete		
	12	DIN	Control mode 0/1 Low level = mode 0	Control mode 0/1 High level = mode 1	
	13	DIN	Start	Teach (Teach)	
	14	DIN	Brake control/Delete remaining path	Jog-	
	15	DIN	Stop		
	16	DIN	Control enable/Acknowledge error		
	17	DIN	Do not connect		Release
	18	-	GND (reference potential)		

1) DIN = digital input; DOUT = digital output

Tab. 4.12 Pin allocation for I/O interface (PNP logic)

4.4.6 External battery [X10]

For devices with multi-turn absolute measurement system (EMCA-EC-...-1TM), position changes are recorded for up to 7 days when fully charged with supply voltage switched off. The duration is extended to up to 6 months with connection of the battery box EADA-A-9 (➔ Tab. 2.7).

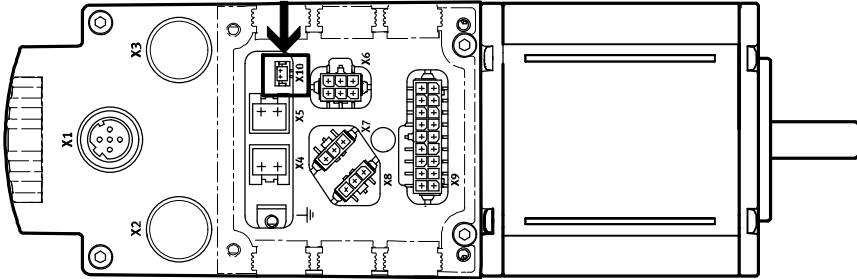

[X10]	Pin	Description
	1	Battery +
	2	Battery – (GND)
		Connection for the external battery box EADA-A-9

Tab. 4.13 Pin allocation of connection for external battery [X10] (only EMCA-EC-...-1TM)



The battery box EADA-A-9 from Festo is suitable.

4.5 Requirements for ensuring IP degree of protection

- Use only connection technology with the corresponding IP degree of protection (→ www.festo.com/catalogue).
- Seal any unused connections with a cover cap. When doing this, make sure the seals are clean! The M12 connection of the device is equipped with an O-ring which ensures the IP degree of protection specified in the Technical data sheet in combination with the following cover caps (included in the scope of delivery):
 - Connection [X1]: cover cap ISK-M12
- To connect the plug connector (connection [X4] to [X10]), use only cable with suitable outside diameter and circular cross section, so that the sealing kits can seal correctly.
- Seal cable throughfeeds of the connection box with the accompanying seal inserts. When doing this, make sure the seals and lines are clean! Replace damaged seals.



Current information on accessories → www.festo.com/catalogue.

5 Commissioning

5.1 Notes on commissioning



Caution

Rapidly rotating motor shaft with high torque.

Contact with the motor shaft can cause burn injuries and abrasions.

- Ensure that the rotating motor shaft and components attached to it cannot be touched.



Warning

Rapidly rotating motor shaft with high torque.

Clothing, jewellery and hair can be caught and wrapped around the shaft. People can be injured as a result.

- Make sure that clothing, jewellery or hair can **not** be caught by the rotating motor shaft.
- Ensure that clothing fits tightly.
- Hair nets must be worn with long hair.



Warning

Danger of burns from hot housing surfaces.

Contact with the motor housing can cause burn injuries. This can frighten people and cause them to act in an unpredictable manner. This can lead to other forms of secondary damage.

- Make sure that unintentional contact is not possible.
- Inform operating and maintenance staff about the possible hazards.



5.2 FCT (Festo Configuration Tool)



The following pages only describe the first few steps in FCT. Implement all other steps in accordance with the instructions in the integrated FCT help system.

5.2.1 Installing FCT



Note

The FCT plug-in EMCA V 1.0.0 supports devices with firmware version V 1.0.x. or later.

- With more recent firmware designs, check whether an updated plug-in is available (→ www.festo.com/sp).

**Note**

Windows administrator rights are required for installing the FCT.

The FCT is installed on your PC with an installation program.

1. Before installation, close all programs.
2. Start installation program (Setup_EMCA....exe).
3. Follow the instructions of the FCT Assistant.

5.2.2 Starting the FCT

Start FCT as follows:

- Double click on the FCT icon on the desktop
- Or in the Windows start menu, select the following menu path:
[Programs][Festo Software][Festo Configuration Tool].

To be able to create a connection to the device, a project must be created or opened in the FCT.

5.2.3 Notes on commissioning with FCT

FCT framework

For information on working with projects and adding a device to a project to a project → Help for the FCT Framework (Command [Help][Contents FCT general]).

EMCA plug-in

The EMCA plug-in for the FCT supports all the steps necessary for commissioning of the device. The necessary parameterisations can be executed on the PC offline and later transferred to the device. This enables preparation for the actual commissioning process, e.g. in the design office when a new system is being planned.

FCT Help

For detailed information about configuration, parameterisation and commissioning → Plug-in Help.

– Command [Help][Contents of installed PlugIns][Festo][EMCA]

The FCT Help also has information about possible commissioning scenarios and initial commissioning.

Printed information

- With the “Print” button of the Help window, individual pages of the FCT Help or all of the pages of a book can be printed directly from the table of contents.
- In the following directories, prepared print versions of the Help are available in PDF format:

Printed version	Directory	File name
FCT help (framework)	...(FCT-Installationsverzeichnis)\Help\	FCT_en.pdf
Plug-in Help (EMCA)	...(FCT-Installationsverzeichnis)\Hardwarefamilies\ Festo\EMCA\...\Help\	EMCA_en.pdf



To view and print out these PDF files, Adobe Reader is recommended.

Loading firmware

The Festo Configuration Tool (FCT) makes it possible to update the device firmware.



Festo provides new firmware designs on the Internet via the Support Portal (➔ www.festo.com/sp).

- When searching for firmware, enter the part number or order reference of the product as search text (➔ product label of the device).

When the firmware is loaded with the FCT, at first only identification data is transmitted to the device.

The device checks if the firmware is compatible with the device.

If the firmware is not compatible, the loading process is terminated and a corresponding error message is generated. If the firmware is compatible with the device, the firmware is transmitted to the device.

When the firmware has been transmitted without error, the device restarts automatically and loads the downloaded firmware.

Restoring factory setting

FCT permits restoring the factory setting of the device. This involves deleting all parameters and restoring the factory presettings. Only the IP configuration remains unchanged at first until the device is restarted.

But firmware updates that have already been made are **not** reversed. The firmware as supplied from the factory can still be reloaded to a device with FCT (➔ FCT, command [Component][Firmware Download]).

5.3 Network connection via Ethernet



Note

On delivery, the integrated DHCP server (Dynamic Host Configuration Protocol) is active. If another DHCP server is active in the network, do **not** connect the device to the network immediately. Two active DHCP servers on a network can lead to network faults.



The factory setting (DHCP server active) is generally not suitable for network operation! A DHCP server is usually already available there! The IP configuration of the device can be set with FCT.

Active DHCP server (factory setting)	
DHCP server	Active
IP address	192.168.178.1
Subnet mask	255.255.255.0
Gateway	– (A gateway is not assigned)

Tab. 5.1 Active DHCP server (factory setting)

Communication of the device with a connected PC takes place via the TCP/IPv4 protocol. In order to create a connection over the Ethernet interface, the IP configuration of the device must fit the configuration of the PC.

- At initial commissioning, connect the device directly to the PC, as the DHCP server of the device is active in the factory setting (→ Chapter 2.7.1).



Recommendation: Use the connecting cable NEBC-D12G4-... from Festo (accessories → www.festo.com/catalogue).

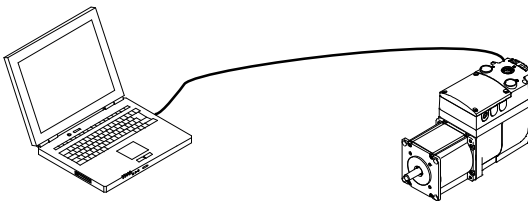

Fig. 5.1 Initial commissioning via point-to-point connection

The DHCP server permits a point-to-point connection between the device and a PC individually configured as a DHCP client. The Ethernet interface used on the PC must have the following (standard) settings → Windows System Control Center:

- “Automatically obtain IP address”
- “Automatically obtain DNS server address”

If the Ethernet interface of the PC is set accordingly, the DHCP server of the device assigns a suitable IP address to the PC.

The DHCP server of the device is not intended for supplying existing networks with IP addresses. The DHCP server issues the following IP configurations:

- IP addresses from the following range: 192.168.178.110 ... 192.168.178.209
- Subnet mask: 255.255.255.0.
- Gateway: – (a gateway is not assigned)

Create network connection – example

Prerequisite:

- The PC is configured as a DHCP client (usually the default setting for PCs).
 - The EMCA is configured as a DHCP server (factory setting).
1. Connect the Ethernet interface of the EMCA directly to the Ethernet interface of the PC (point-to-point connection).
 2. Switch on the power supply of the device.
The DHCP server of the device then assigns an IP address to the PC. This establishes the network connection.

Testing the network connection

1. **Start the web browser** of the PC (Internet Explorer > 6; Firefox > 3; activate JavaScript).
2. Type the IP address of the device (factory setting: 192.168.178.1) into the address bar. Then the web site of the device appears (→ Chapter 5.5).

Or:

Start FCT and establish an online connection (→ FCT, command [Component][Online][Login]).

Actions in case of communication problems

- Check the TCP/IPv4-settings of the used Ethernet interface of the PC (→ Windows System Control):
 - “Obtain an IP address automatically”
 - “Obtain DNS server address automatically”

5.3.1 Displaying or changing network configuration

IP configuration can be carried out with FCT. FCT also offers a search function (network scan) with which a device can be found in the network without knowledge of the current IP configuration.

Scanning network

- If there is no online connection to the device yet, start network scan with FCT (→ FCT, command [Component][FCT Interface], button “Scan...”).
The devices found are then displayed in a list.

Changing network setting

If there is no online connection:

1. Scan network and mark the found device in the list.
2. In the context menu, select the command [Network].
The current network setting is then displayed and can be changed.
3. Change network setting and confirm the change with OK.
The network setting is then displayed.

If an online connection already exists:

1. In the menu [Component], select the command [Online][Setup Network Settings ...].

The current network setting is then displayed and can be changed.

2. Change network setting and confirm the change with OK.

The changes take immediate effect and are automatically stored in the device.

Possible network settings (→ also chapter 2.7.1)

- DHCP server active (factory setting, → Tab. 5.1)
- DHCP-Client (“Obtain IP address automatically”): EMCA obtains the IP address from a DHCP server in your network.
- Fixed IP address: A fixed IP address can be assigned to the device.

5.3.2 Security in the network



Note

Unauthorised access to the device can cause damage or malfunctions. When connecting the device to a network:

- Protect the network against unauthorised access.

Measures to protect the network include:

- Firewall
- Intrusion Prevention System (IPS)
- Network segmentation
- Virtual LAN (VLAN)
- Virtual Private Network (VPN)
- Security at physical access level (port security).

For additional information → Guidelines and standards for security in information technology, e.g. IEC 62443, ISO/IEC 27001.



Recommendation: Activate password protection to avoid accidental access to the device (→ FCT, command [Component][Online][Password]).

Password protection

In the delivery status of the device, password protection is inactive. With FCT, password protection can be activated through entry of a password (→ FCT Help).

Access via ...	Description
FCT	<p>If a password has been established, it is queried when the online connection is established.</p> <ul style="list-style-type: none"> – After the correct password is entered, all functions from FCT are enabled until the next time the data connection is severed. – Without entry of the password, settings and parameters can only be read with FCT. The control and parameterisation options over FCT are blocked.
Web servers	<p>In read access via the web server, the password is not queried. The password query is made only when there is an attempt to load a parameter file into the device.</p>

Tab. 5.2 Effects of password protection



The web server does not support an HTTPS connection. The password is transferred insecurely. The web browser notes the entered password until it is closed. Before the web browser is closed, the buffer memory (cache) of the web browser should be deleted as a precaution.

5.4 Master control

Master control determines through which interface the device may be controlled. The device cannot be controlled over several interfaces simultaneously. The following interfaces can receive master control:

- Control interface (I/O interface or Modbus® TCP)
- Parameterisation interface (master control through FCT or web server)

Simultaneous connections

Several connections simultaneously are technically possible via the parameterisation interface, e.g. over several web browsers or FCTs. If master control has been transferred to the parameterisation interface, parameterisation and control are possible only over the first connection. All other connections have only read rights (for diagnostics). Changeover is possible in enabled as well as in non-enabled status. That means, the device does not prevent changeover of master control during an active movement.



Recommendation: Before the changeover of master control, a stop command should be sent through the interface with master control.

The enable signal of the interface that currently has master control is always valid. If, for example, the FCT switches over to the control interface, the enable signal of the control interface applies from the switchover time on.

Active and passive connections via Ethernet interface

A maximum of 3 simultaneous connections are permitted on the device via the Ethernet interface, depending on the control interface selected:

Number of connections via ...	Control interface	
	I/O interface	Modbus® TCP
Web servers	1	1
FCT	2	1
Modbus®/TCP (FHPP)	-	1

Tab. 5.3 Number of simultaneously permissible connections

If 2 connections are created over FCT, the first connection made is the active one. The second connection is passive. A passive connection cannot become an active connection. For that, both connections would first have to be terminated, then rebuilt in the desired sequence.

Connections	Rights
Active connection	Write rights for parameterisation, control, transfer of master control and read rights
Passive connection	Read rights for diagnostics

Tab. 5.4 Connections and rights via Ethernet interface

A web server connection can always be built up. If FCT does not have master control, the web server connection can take over master control to load a parameter file.

Switching over master control

After the device is switched on, the control interface always has master control. The active FCT connection can take over master control from the control interface if the control interface does not block it. Changeover is possible in enabled as well as in non-enabled status. Master control can also be taken over during execution of an order. For this, an ongoing order is stopped (Quick Stop).

Connection	Switching over master control
FCT	Can take over master control from all other connections (Device Control: activate FCT). When the device control is deactivated, master control is restored to the control interface.
Web server	To transfer the parameter file, the web server can take over master control from the control interface. When the procedure is ended, master control is restored to the control interface.

Tab. 5.5 Changeover of device control

To remove master control from the control interface and transfer it to FCT:

- In the online tab “Operate” under “Device Control”, activate the “FCT” checkbox.

For the FCT to control the connected device, the “Enable” checkbox must be activated after takeover of master control.

If master control is released again by FCT, it automatically goes back to the control interface.

Blocking switchover of master control (only over Modbus® TCP)

Switchover of master control can be blocked over the Modbus® TCP (FHPP) control interface (control bit CCON.LOCK). Switchover from the control interface to the parameterisation interface is possible only after the block is released (➔ description of device profile FHPP, GDCE-EMCA-EC-C-HP-....).

Time-out

When FCT has master control, the device detects when the connection to the FCT software has been interrupted. The device then behaves as parameterised in FCT on the page “Error Management” (mal-function number 0x32). The time-out time is typically 1 s. For slow networks, a longer time-out time can be selected.

5.5 Online connection with the web server

Requirements for call-up of the web server

- The power supply of the device is switched on.
- The IP configuration of the device is correctly set (→ Chapter 2.7.1, Tab. 2.45).
- Device and PC are connected via the Ethernet interface (direct connection or connection over a network).

IP address of the device

In the factory setting, the device has the following IP address: 192.168.178.1.

If the IP configuration of the device has been changed, the current IP address can be determined with FCT (→ FCT, command [Component] [FCT Interface], button “Scan...”).

Call the web server

1. Open Internet browser, e.g. Internet Explorer version 6 or later or Firefox version 3 or later.
2. Enter the IP address of the device in the address line of the Internet browser.

Then the web site of the device appears.

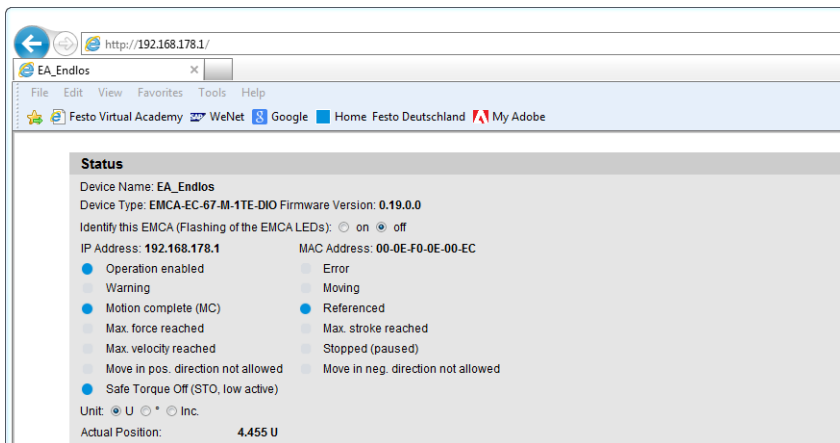

Fig. 5.2 Website of the web server

Active signals are marked with a blue dot. Inactive signals are marked with a grey dot.

Sections of the website	Description
Status (Status)	Shows status information about the device
Basic I/O interface: (Basic I/O Interface)	Shows signal statuses of the digital basic I/Os
I/O interface (I/O Interface)	Shows signal statuses of the digital I/Os

Sections of the website	Description
Upload/download parameters (Parameter Up-/Download)	Permits uploading and downloading of a parameter file (→ Chapter 5.7)
Diagnostic memory (Diagnostic Memory)	Permits read-out and display of the diagnostic memory (→ Chapter 6.1)

Tab. 5.6 Sections of the website of the web server

5.6 Commissioning steps

Overview

Preparations for commissioning

1. Check mounting of the axis assembly and seal inserts as well as cable throughfeeds (→ Chapter 3).
2. Check wiring of the device (→ Chapter 4).
3. Create FCT project (→ Help for the EMCA plug-in).
4. Establish connection with the PC and set network configuration (→ Chapter 5.3).

The following steps must be performed in the initial commissioning:

1. Perform configuration and parameterisation with the FCT software (hardware configuration, limit values and parameters) (→ Chapter 5.6.1 as well as Help for the EMCA plug-in)
2. With use of safety function STO: check the STO function (→ Documentation GDCE-EMCA-EC-S1-...)
3. Check signal characteristics of the digital I/O (e.g. limit/reference switch).
4. Provide required control signals (→ Chapter 5.6.4).
5. Check direction of rotation/direction of travel of the electromechanical drive (e.g. in jog operation).
If required, activate reversing of rotation to reverse the direction (→ FCT, command [Application Data], [Environment], “Inverse Rotation Polarity”).
6. Perform homing (→ Chapter 2.4.2).
7. Test positioning behaviour (test mode → Help for the EMCA plug-in).
8. Optimise controller setting (optional, → Help for the EMCA plug-in).
9. Complete commissioning (→ Help for the EMCA plug-in).

5.6.1 Configuration and parameterisation

- Perform configuration and parameterisation conscientiously.
- Do **not** operate the device with unknown settings.
- If the system structure consists of Festo components, parameters and limit values are preset by the plug-in.
- If the system structure contains user-specific components, parameters and limit values must be determined based on the system structure. For example, the maximum motor current can be limited so the permissible load of a system component is not exceeded.
- Application-related parameters and limit values must be determined based on the application.



For detailed information on parameterisation and optimisation of the controller setting
→ Plug-in Help of the FCT.

Load parameter file

If a parameter file (*.fpf) is available for the project, the following options exist:

- The parameter file can be downloaded with the web server directly into the device (→ Chapter 5.7).
- The parameter file can be imported into an FCT project and downloaded into the device (→ FCT Help).

5.6.2 Checking STO function

With use of the safety function STO [X6]:

The safety function STO must be validated before commissioning (in accordance with EC Machinery Directive).



For additional information on intended use of the safety function “Safe torque off/STO”
→ Description GDCE-EMCA-EC-S1-...

5.6.3 Check signal characteristics of the limit and reference switch

- Check connection and mounting of the limit and reference switches.

If limit switches are to offer a certain protection against travel to mechanical stops or end positions, they must become effective at sufficient distance from the stops or end positions (through corresponding switching ranges or suitable design measures).



To avoid homing errors, there must no range between the limit switch and the nearest stop or end position in which the limit switch is not actuated (undefined range). Ferritic elements in the vicinity of magnetic switches can influence the switching range (e.g. mounting components).

With FCT, the inputs for limit and reference switches must be activated and the switch type used correctly configured (→ FCT, page “Axis”, tab “Axis Options”).

5.6.4 Providing required signals (digital I/Os)

Switching of the digital inputs and outputs for control via Modbus® TCP

For commissioning and operation, the device needs the following signals:

- Signals STO 1 and STO 2 (STO interface) → description of safety function STO, GDCE-EMCA-EC-S1-...
- For release logic DIN + controller (→ Tab. 2.50): signal “Control enable” (I/O interface)

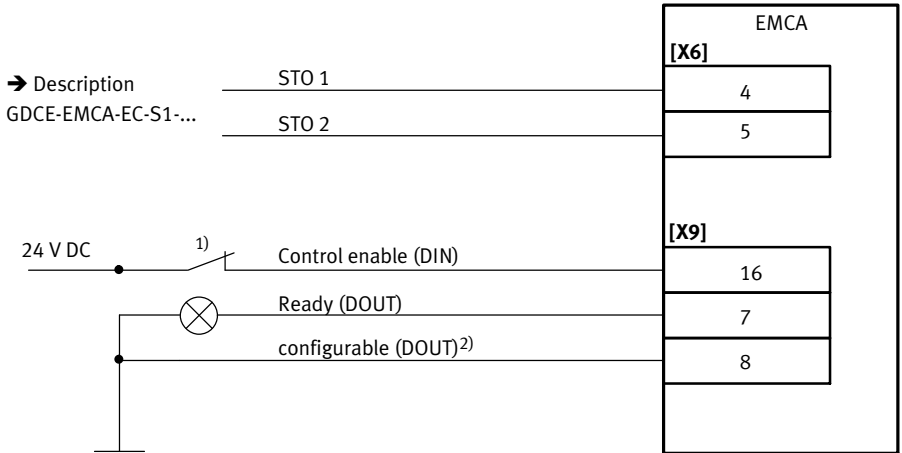

1) Switch setting with switched-on controller enable

2) Optional; output in the Festo Configuration Tool (FCT) freely configurable (e.g. “common error”)

Fig. 5.3 Connection: digital inputs/outputs for operation – enable logic: DIN + controller

Switching of the digital inputs and outputs for control via the I/O interface

For commissioning and operation, the device needs the following signals through the I/O interface and the STO interface:

- STO interface (2-channels): signals STO 1 and STO 2 → description of safety function STO, GDCE-EMCA-EC-S1-...
- I/O interface: signal Control enable

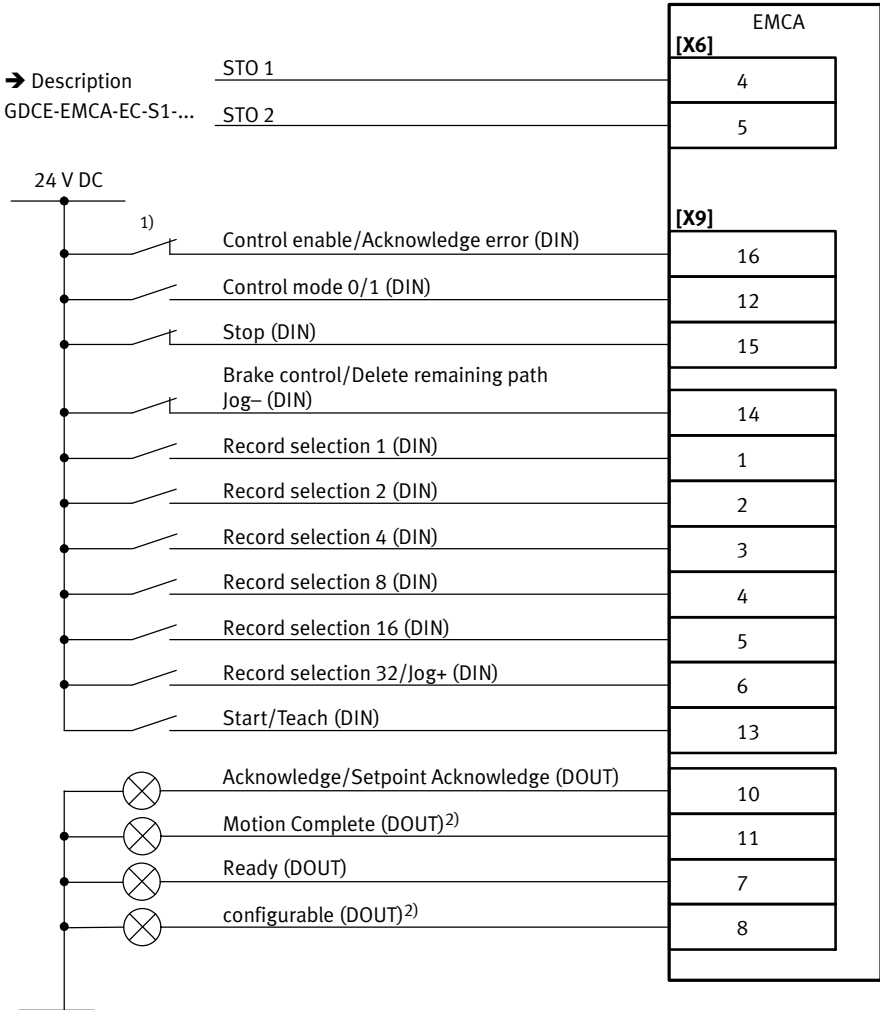

1) Switch setting with switched-on controller enable

2) Optional; output in the Festo Configuration Tool (FCT) freely configurable (e.g. "common error")

Fig. 5.4 Connection: digital inputs/outputs for operation

5.6.5 Checking direction of rotation/travel direction

In the online register “Manual Move”, FCT offers access to jog operation. With jogging, the motor can be moved manually to visually check the direction of rotation. Homing is not required for this (➔ FCT Help).

Prerequisites are:

- STO function is not requested.
- Enable signal is present at the “Control enable/Acknowledge error” input.
- Online connection with the EMCA is established.
- FCT has master control (➔ FCT, “Device Control”, “FCT”).
- The drive is enabled (➔ FCT, “Device Control”, “Enable”).
- Carefully check direction of rotation with jogging (Observe drive).
- If required, reverse direction of rotation with the “Reverse direction of rotation” parameter (➔ FCT, page “Application Data”, tab “Environment”, “Inverse Rotation Polarity”).

5.6.6 Carrying out homing



Recommendations for parameterisation

- Do not change default settings, if possible. If changes are required:
 - Select low search/crawl speed to enable the target points to be identified as accurately as possible.
 - Set deceleration high enough to prevent the target points from being overrun during the search run.

In the online register “Homing”, FCT offers access to the Homing drive function.

Prerequisites are:

- STO function is not requested.
- Enable signal is present at the “Control enable/Acknowledge error” input.
- Online connection with the EMCA is established.
- FCT has master control (➔ FCT, “Device Control”, “FCT”).
- The drive is enabled (➔ FCT, “Device Control”, “Enable”).

5.6.7 Testing positioning behaviour (test mode)

Through manual movement with FCT, it can be determined whether the device is fundamentally ready for operation. In addition, the settings of the measuring reference system and the software end positions can be checked.

FCT makes it possible to record drive data over a defined period in real time, e.g. speeds and contouring errors during a movement.

For additional information on this ➔ Help on the EMCA plug-in.

5.6.8 Optimising controller setting (optional)

When using Festo components:

- The controller parameters are calculated by the FCT plug-in and preset.

When using user-specific components or if the control behaviour should be further optimised:

- Optimise controller settings as described in the Help for the EMCA plug-in (➔ Help for the EMCA plug-in).

5.6.9 Completing commissioning

Recommendation: disable “Automatic saving” option

- Under FCT [...] [Controller] [I/O Configuration] disable the automatic saving of taught positions in the Flash memory



Note

Loss of device data

If the power supply is interrupted, any modifications made to the device data that have not been saved to the permanent memory will be lost.

- Save each change to the device data in the permanent memory of the device (FCT: Store).

When downloading (Download) parameters with FCT, the data are stored only temporarily in the device. The temporarily stored data are lost when the power supply is switched off.

To conclude commissioning:

- Recommendation: Activate password protection (➔ Help for the EMCA plug-in).
- Save parameters permanently in the device (➔ Help for the EMCA plug-in).
- Recommendation: Save parameters of the device in a parameter file (➔ Chapter 5.7).

5.7 Saving or loading parameter file

The parameterisation of the device can be read out and saved as a file with the format *.fpf. Parameter files with this format can be transferred to devices of the same design. In a download, the selected parameter file is written to the permanent memory of the device. This permits:

- restoration of the parameterisation
- fast transfer of all parameters to several identical devices
- fast parameterisation of new devices when service is needed (replacement of devices)

Uploading (reading out) of parameter files from devices and downloading into devices can be performed with:

- FCT (→ Help for the FCT, command [Component][Online][Backup Recovery ...])
- the web server



Recommendation: Save parameters of the device in a parameter file after successful commissioning.

For the web server, the commands for uploading (Upload) and downloading (Download) of the parameter file are located in the section “Parameter Up-/Download” of the website of the device (→ Fig. 5.5 and chapter 5.5):

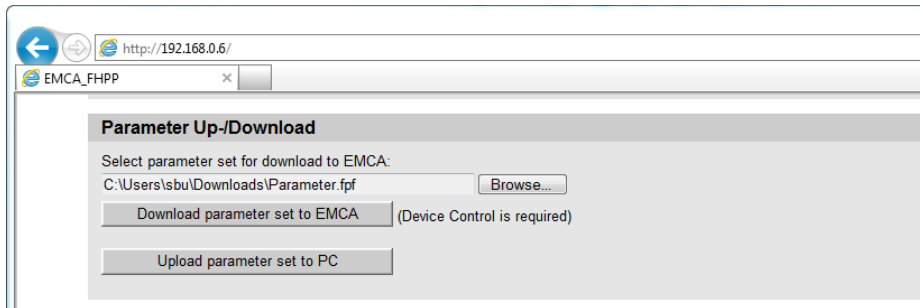

Fig. 5.5 Section “Parameter Up-/Download”

Command	Description
Download parameter set to EMCA	Transfer parameter file to the device memory.
Upload parameter set to PC	Upload parameter file and save it on the PC.

Tab. 5.7 Commands in the section Parameter Up-/Download

Further options

With FCT, a parameter file can be imported into the current project and parameters of the current project exported into a parameter file (→ FCT, command [Component][Import/Export]).

5.8 Notes for operation

The device is controlled via the I/O interface.



More information → Chapter 2.8.

5.8.1 Maximum writing cycles of the flash memory

Stored in the integrated flash memory are parameter files, for example. In addition, firmware updates are stored in the flash memory. In principle, the number of possible write cycles is limited. The FLASH memory is designed for 100,000 write cycles.

With the following procedures, entries are written to the flash memory:

- Teaching with automatic storage
- download of a new parameter file
- firmware update
- “Store” in FCT
- Configuration of fault characteristics/error responses
- Recording of movements with the trace function in FCT



Note

Damage to the FLASH memory

In position mode, the target positions for absolute command sets can be taught and automatically saved via the I/O interface.

- Only use the TEACH function in combination with automatic storage for commissioning and not in continuous operation. This would otherwise rapidly use up the permitted number of write cycles.
- Disable automatic saving after commissioning via FCT (→ FCT, [Controller][I/O Configuration]).

6 Diagnostics and fault clearance



For information on classification of diagnostic messages of the device and parameterisation of possible error responses → Chapter 2.6.4 and FCT Help, keyword “Error Management”.

When an error occurs, the device goes into error status. The output “Ready” is hereby reset to “Low”.

Acknowledge error

Some errors can be acknowledged immediately, e.g. a following error. For other errors, the cause of the error must be remedied first, e.g. temperature error, load voltage error. For some errors, a restart of the device is necessary, e.g. encoder errors.

For error-specific information on readiness for acknowledgment → List of diagnostic messages in chapter 6.3.2.

Acknowledgeable error messages can be acknowledged as follows:

- Festo Configuration Tool (→ FCT online Help)
- rising edge at the input “Control enable”



If errors cannot be acknowledged, the device must be switched on again (power OFF/ON). Diagnostic events that are parameterised as warnings are displayed once and do not need to be acknowledged.

6.1 Access to the diagnostic memory

The diagnostic memory of the device (→ Chapter 2.6.5) can be accessed as follows:

Access via	Options
FCT	In online mode, the diagnostic memory can be read out, displayed, deleted or exported (→ Help on FCT – online register “Diagnosis”).
Web servers ¹⁾	Read out and display diagnostic memory.

1) For information on the web server → Chapter 5.5.

Tab. 6.1 Access to the diagnostic memory

The web server of the device displays the section “Diagnostic Memory” (diagnostic memory) as the last section of the English-language website. The most recent diagnostic message is displayed in the top row.

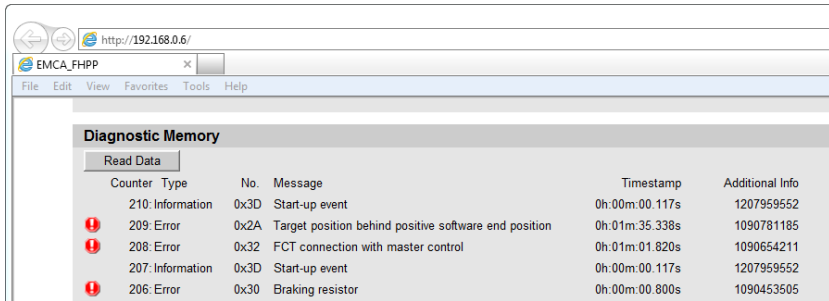

Fig. 6.1 Display of the diagnostic memory on the website

Information	Description
Counter (Counter)	Counter number of the diagnostic message. The most recent message (top) has the highest number.
Type (Type)	Classification of the diagnostic message (→ Chapter 2.6.4) <ul style="list-style-type: none"> – Error – Warning – Information For additional information → Chapter 2.6.4.
Number (No.)	Number of the diagnostic message in hexadecimal notation (0x = hex prefix).
Message (Message)	Brief English-language description
Timestamp (Timestamp)	Time of the diagnostic message in the form HH.MM.SS:nnn (HH = hours, MM = minutes, SS = seconds, nnn = milliseconds). The time base is the respective switch-on time of the device.
Additional info (Additional Info)	Additional information for Festo Service

Tab. 6.2 Information for diagnostic messages

Deleting the diagnostic memory

The content of the diagnostic memory can be deleted:

- with the FCT, “Delete” button (→ FCT online Help)

During deletion, a “start-up event” (Start-up event, message 3Dh) is generated and entered in the diagnostic memory. The malfunction counter is not reset.

6.2 Diagnostics via LED

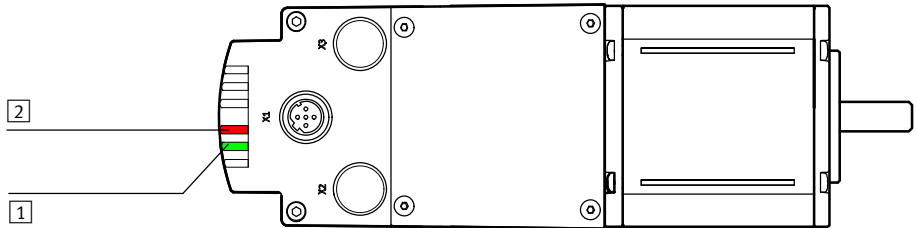

1 OK LED (green)

2 FAULT LED (red)

Fig. 6.2 LED of the device (example EMCA-EC-67-S-1TE-DIO)

6.2.1 Behaviour during the switch-on phase

LED	LED status	Event/status
OK	Flashes green	– Start-up phase, bootloader active
ERROR	Flashes red	

Tab. 6.3 Behaviour in the switch-on phase

6.2.2 Behaviour in the operating phase

LED	LED status	Event/status
OK	Off	– Hardware is not ready for operation; an error is present.
	Flashes green	– Hardware is ready for operation; but the signal “Control enable” is not present.
	Green	– Normal operating status; hardware is ready for operation; signal “Control enable” is present
ERROR	Off	– No error, no warning
	Flashes red	– A warning is indicated.
	Red	– An error is reported.

Tab. 6.4 Behaviour in the operating phase

6.2.3 Identification sequence active

LED	LED status	Event/status
OK	Flashing at the same time	Feedback to the optical identification active (can be activated via the web server)
ERROR		

Tab. 6.5 Identification sequence active

6.2.4 Behaviour with errors in the firmware update phase

LED	LED status	Event/status
OK	Off	Firmware update was cancelled due to an error.
ERROR	Flashes red ¹⁾	

1) The dark phase is 10 times as long as the switch-on phase.

Tab. 6.6 Behaviour during a firmware update

Actions in the event of an error

- Switch device off and back on.
- Restart the firmware download process.
- If the error occurs repeatedly, contact your local Festo Service.

6.3 Diagnostic messages, causes and remedies



The error management of FCT makes it possible to parameterise the reaction to diagnostic messages of the device (→ Chapter 2.6.4).

6.3.1 Explanations of the diagnostic messages

The table of the diagnostic messages (→ Chapter 6.3.2) contains the following information:

Term	Significance
No.	Number of the diagnostic message in hexadecimal notation (FCT code)
Can be parameterised as ...	F/W/I = Fault/warning/information (see chapter 2.6.4) Indicates which classification is possible for a diagnostic message. The factory setting is printed in bold (here F). If a classification is not possible, this is indicated by dashes. Example: “F/-/-” means that the diagnostic message can only be classified as a fault.
Diagnostic memory	Indicates whether an entry is always made in the diagnostic memory, or whether this can be parameterised in FCT (always/optional)
Acknowledgeability	Contains information about the ability to acknowledge The specification software reset means that a restart is required (either by switching off and back on or via FCT (→ FCT, command [Component])[Online] [Restart Controller]).
Parameterisable error response(s)	For every diagnostic message, provides the parameterisable error response as code letters (A to G) (→ Tab. 6.8) Code letters for the factory response settings are printed in bold.

Tab. 6.7 Explanations for table of error messages (→ Chapter 6.3.2)

Code letters for the parameterisable error response(s)

A	Free run-out – no braking ramp	Deactivate output stage
B	Quick-Stop deceleration – quick-stop braking ramp	After that, switch off output stage
C	Set deceleration - turn off braking ramp of the current position set	
D	End record - execute record to Motion Complete (MC)	The output stage remains switched on
E	Quick-Stop deceleration – quick-stop braking ramp	
F	Set deceleration - turn off braking ramp of the current position set	
G	End record - execute record to Motion Complete (MC)	

Tab. 6.8 Possible error responses (can be parameterised)

6.3.2 Diagnostic messages with instructions for fault clearance

Diagnostic messages and fault clearance		
01h	Software error	Can be parameterised as: F/-/- Diagnostic memory: always
<p>An internal firmware error has been detected.</p> <ul style="list-style-type: none"> • Contact Festo repair service. – Resetable: Cannot be reset, software reset is necessary. <p>Definable error response(s): A</p>		
02h	Default parameter file invalid	Can be parameterised as: F/-/- Diagnostic memory: always
<p>An error has been detected when examining the default parameter file. The file is damaged.</p> <ul style="list-style-type: none"> • Reload the default parameter file into the device via a firmware update. If the error is still present, it means the memory may be faulty and the device needs to be replaced. – Resetable: Cannot be reset, software reset is necessary. <p>Definable error response(s): A</p>		
03h	Internal communication error CPUs	Can be parameterised as: F/-/- Diagnostic memory: always
<p>An error has been detected in internal communication.</p> <ul style="list-style-type: none"> • Restart device. If the error occurs frequently, the device must be replaced. – Resetable: Cannot be reset, software reset is necessary. <p>Definable error response(s): A</p>		
04h	Non-permitted hardware	Can be parameterised as: F/-/- Diagnostic memory: always
<p>Internal electric circuitry is faulty.</p> <ul style="list-style-type: none"> • The device must be replaced immediately. – Resetable: Cannot be reset, software reset is necessary. <p>Definable error response(s): A</p>		
06h	Encoder	Can be parameterised as: F/-/- Diagnostic memory: always
<p>An error has occurred during evaluation of the encoder. The current position values may be incorrect.</p> <ul style="list-style-type: none"> • Conduct a software reset and homing procedure. – Resetable: Cannot be reset, software reset is necessary. <p>Definable error response(s): A</p>		

Diagnostic messages and fault clearance		
07h	Limit switch positive	Can be parameterised as: F/-/- Diagnostic memory: optional
<p>The drive is at the positive limit switch.</p> <ul style="list-style-type: none"> • Acknowledge error and move the drive in a negative direction to the permissible range. Also check the movement range and record parameters, if necessary. • Check switches and cables. • Check positioning dynamics (overshoot?), e.g. with trace diagrams in FCT. <p>– Resettable: Error can be reset immediately. Definable error response(s): A, B, C, E, F</p>		
08h	Limit switch negative	Can be parameterised as: F/-/- Diagnostic memory: optional
<p>The drive is at the negative limit switch.</p> <ul style="list-style-type: none"> • Reset error and move the drive in a positive direction into the permissible range. Also check the movement range and record parameters, if necessary. • Check switches and cables. • Check positioning dynamics (overshoot?), e.g. with trace diagrams in FCT. <p>– Resettable: Error can be reset immediately. Definable error response(s): A, B, C, E, F</p>		
09h	Offset determination for current measurement	Can be parameterised as: F/-/- Diagnostic memory: always
<p>An error has occurred during initialisation of the current measurement.</p> <ul style="list-style-type: none"> • Perform a software reset. <p>– Resettable: Cannot be reset, software reset is necessary. Definable error response(s): A</p>		
0Ah	General error	Can be parameterised as: F/-/- Diagnostic memory: always
<p>An internal error has occurred.</p> <ul style="list-style-type: none"> • Restart device. If the error occurs frequently, contact Festo Service. <p>– Resettable: Error can be reset immediately. Parameterisable error response(s): B</p>		
0Bh	Parameter file invalid	Can be parameterised as: F/-/- Diagnostic memory: always
<p>No valid parameter set stored. After creation of the parameter file, a firmware update is performed, if necessary: As much data as possible is automatically loaded from the parameter file. Parameters that are not initialised by the parameter file are loaded from the default parameter file.</p> <ul style="list-style-type: none"> • Enter a valid parameter set in the device. If the error is still present, the hardware may be defective. <p>– Resettable: Error can be reset immediately. Definable error response(s): A</p>		

Diagnostic messages and fault clearance		
0Ch	Firmware update execution error	Can be parameterised as: F/-/- Diagnostic memory: optional
<p>The firmware update has not been properly executed or completed.</p> <ul style="list-style-type: none"> • Check Ethernet connection between device and PC. Restart device and perform the firmware update again. Check whether valid firmware has been selected for the device. The previous firmware version remains active until the firmware update has been successfully completed. If this error is still present, the hardware may be defective. – Resettable: Cannot be reset, software reset is necessary. Definable error response(s): A 		
0Dh	Overcurrent	Can be parameterised as: F/-/- Diagnostic memory: always
<p>Short circuit in the motor, lines or brake chopper. Output stage defective. Incorrect parameterisation of the current regulator.</p> <ul style="list-style-type: none"> • Check parameterisation of the current regulator. An incorrectly parameterised current regulator can generate currents up to the short-circuit limit; as a rule this is clearly noticeable through high frequency whistling. Inspection with the trace function in FCT (active current actual value). • Error message immediately after connecting to the load supply: Short circuit in the output stage. The device must be replaced immediately. • Error message only occurs when setting the output stage enable: Short circuit in motor or the (internal) motor cables. Replace device. • Error occurs only with active brake chopper: Check external braking resistor for short circuit or insufficient resistance value. – Resettable: Cannot be reset, software reset is necessary. Definable error response(s): A 		
0Eh	I²t malfunction motor	Can be parameterised as: F/-/- Diagnostic memory: always
<p>The I²t limit for the motor is reached. The motor or the drive system may be insufficient for the required task.</p> <ul style="list-style-type: none"> • Check the layout of the drive system. • Check the mechanics for sluggishness. • Reduce load/dynamic response, longer time delays. – Resettable: Error can only be reset after the cause of the error has been eliminated. Definable error response(s): B, C 		

Diagnostic messages and fault clearance		
11h	Software limit positive	Can be parameterised as: F/-/- Diagnostic memory: optional
<p>The position setpoint has reached or exceeded the respective software end position.</p> <ul style="list-style-type: none"> • Check target data. • Check positioning area. • This error can be reset immediately. Afterwards start a corresponding positioning record or move the drive by using the jogging function. Movements in a positive direction are blocked. – Resettable: Error can be reset immediately. <p>Definable error response(s): A, B, C, E, F</p>		
12h	Software limit negative	Can be parameterised as: F/-/- Diagnostic memory: optional
<p>The position setpoint has reached or exceeded the respective software end position.</p> <ul style="list-style-type: none"> • Check target data. • Check positioning area. • This error can be reset immediately. Afterwards start a corresponding positioning record or move the drive by using the jogging function. Movements in a negative direction are blocked. – Resettable: Error can be reset immediately. <p>Definable error response(s): A, B, C, E, F</p>		
13h	Positive direction locked	Can be parameterised as: F/-/- Diagnostic memory: optional
<p>A limit switch error or a software limit position error has occurred and subsequent positioning in the blocked direction has been initiated.</p> <ul style="list-style-type: none"> • Check target data. • Check positioning area. • This error can be reset immediately. Afterwards start a corresponding positioning record or move the drive by using the jogging function. Movements in a positive direction are blocked. – Resettable: Error can be reset immediately. <p>Definable error response(s): A, B, C, E, F</p>		

Diagnostic messages and fault clearance		
14h	Negative direction locked	Can be parameterised as: F/-/- Diagnostic memory: optional
<p>A limit switch error or a software limit position error has occurred and subsequent positioning in the blocked direction has been initiated.</p> <ul style="list-style-type: none"> • Check target data. • Check positioning area. • This error can be reset immediately. Afterwards start a corresponding positioning record or move the drive by using the jogging function. Movements in a negative direction are blocked. <p>– Resettable: Error can be reset immediately. Definable error response(s): A, B, C, E, F</p>		
15h	Output stage temperature exceeded	Can be parameterised as: F/-/- Diagnostic memory: optional
<p>The permissible limit value for the output stage temperature has been exceeded. The output stage is possibly overloaded.</p> <ul style="list-style-type: none"> • This error can only be acknowledged if the temperature is within the permissible range. • Check cylinder sizing. • Check the mechanics for sluggishness. • Reduce the ambient temperature, improve heat dissipation. Check ambient temperature. Consider power derating. <p>– Resettable: Error can only be reset after the cause of the error has been eliminated. Definable error response(s): A, B, C, D</p>		
16h	Output stage temperature too low	Can be parameterised as: F/-/- Diagnostic memory: optional
<p>The ambient temperature is below the permissible range.</p> <ul style="list-style-type: none"> • Increase the ambient temperature. This error can only be reset if the temperature is within the permissible range. <p>– Resettable: Error can only be reset after the cause of the error has been eliminated. Definable error response(s): A, B, C, D</p>		
17h	Logic voltage exceeded	Can be parameterised as: F/-/- Diagnostic memory: optional
<p>The logic power supply monitor has detected an overvoltage. This is either due to an internal defect or an excessive supply voltage.</p> <ul style="list-style-type: none"> • Check external supply voltage directly on the device. • If the error is still present after a reset has been conducted, it means there is an internal defect and the device has to be replaced. <p>– Resettable: Error can only be reset after the cause of the error has been eliminated. Definable error response(s): A, B</p>		

Diagnostic messages and fault clearance		
18h	Logic voltage too low	Can be parameterised as: F/-/- Diagnostic memory: optional
<p>The logic power supply monitor has detected an undervoltage. There is either an internal defect or an overload/short circuit caused by connected peripherals.</p> <ul style="list-style-type: none"> • Separate device from the entire peripheral equipment and check whether the error is still present after reset. If it is, it means there is an internal defect and the device has to be replaced. – Resettable: Cannot be reset, software reset is necessary. <p>Definable error response(s): A</p>		
19h	Real time error LM-CPU	Can be parameterised as: F/-/- Diagnostic memory: optional
<p>The LM-CPU requires more computation time than is available to it.</p> <ul style="list-style-type: none"> • Check whether multiple connections have been established to the device. If yes, terminate the unneeded connections. Further remedial measures: Do without trace drawings, reduce bus load – Resettable: Error can be reset immediately. <p>Definable error response(s): A, B</p>		
1Ah	Intermediate circuit voltage exceeded	Can be parameterised as: F/-/- Diagnostic memory: always
<p>Load voltage not within the permissible range. Braking resistor is overloaded; too much braking energy which cannot be dissipated quickly enough. Braking resistor is defective or not connected.</p> <ul style="list-style-type: none"> • Check power supply; measure voltage directly at the device. • Check the design of the external braking resistor. The resistance value is possibly too large. • Check the connection to the braking resistor. – Resettable: Error can only be reset after the cause of the error has been eliminated. <p>Definable error response(s): A, B</p>		
1Bh	Intermediate circuit voltage too low	Can be parameterised as: F/W/- Diagnostic memory: optional
<p>The load voltage is too low.</p> <ul style="list-style-type: none"> • Voltage drops under load: power supply unit too weak, supply line too long, cross section too small? • If you intentionally want to operate the device with a lower voltage, parameterise this malfunction as a warning. – If parameterised as an error: The error can only be reset after the cause is eliminated. <p>Parameterisable error response(s): A</p> <ul style="list-style-type: none"> – For parameterisation as a warning: The warning disappears if the load voltage is back within the permissible range. 		

Diagnostic messages and fault clearance		
20h	FHPP+ incorrect parameterisation	Definable as: F/W/- Diagnostic memory: optional
<p>Parameterisation of the FHPP+ telegram entries is faulty. The PNU may not be present on the device, or a 16-bit value has been mapped to an odd address.</p> <ul style="list-style-type: none"> • Check entries in the telegram editor. An overview of the PNUs available in the device and their size can be found in the FHPP documentation of your device. – If defined as an error: The error can only be reset after the cause is eliminated. Definable error reaction(s): B, C, D, E, F, G – If defined as a warning: The warning disappears when a valid telegram entry is written. 		
21h	FHPP+ incorrect value	Definable as: F/W/I Diagnostic memory: optional
<p>At least one PNU has been assigned an invalid value. The telegram has been ignored.</p> <ul style="list-style-type: none"> • Correct the values <input type="checkbox"/><input type="checkbox"/> and send the telegram again. – If defined as an error: Error can be reset immediately. Definable error reaction(s): B, C, D, E, F, G – If defined as a warning: The warning disappears when a valid telegram is received. 		
22h	Homing	Can be parameterised as: F/-/- Diagnostic memory: optional
<p>Homing run to switch unsuccessful. A corresponding switch has not been found.</p> <ul style="list-style-type: none"> • Check to make sure the correct homing method is set. • Check whether the limit switches and/or reference switches are connected and have been parameterised correctly (normally closed contact/normally open contact?). Check the functionality of the switches and the lines for wire breaks. • If the error is still present, it means there is an internal defect and the device has to be replaced. – Resettable: Error can be reset immediately. Definable error response(s): B, C, E, F 		
23h	No index pulse found	Can be parameterised as: F/-/- Diagnostic memory: optional
<p>Error during homing: no zero pulse found. Defective encoder.</p> <ul style="list-style-type: none"> • Restart device. If the error occurs again, the device needs to be replaced. – Resettable: Cannot be reset, software reset is necessary. Definable error response(s): B, C, E, F 		

Diagnostic messages and fault clearance		
25h	Path calculation	Can be parameterised as: F /-/ - Diagnostic memory: optional
<p>The positioning target cannot be reached through the positioning options or the edge conditions. During record sequencing: the end speed of the last record was higher than the target speed of the following record.</p> <ul style="list-style-type: none"> • Check the parameterisation of the affected records. • Also check the actual values of the previous positioning process at the switching point, if necessary, by using the trace function. The error may be caused by the actual speed or the actual acceleration being too high at the switching point. <p>– Resettable: Error can be reset immediately. Definable error response(s): A</p>		
27h	Save parameters	Can be parameterised as: F /-/ - Diagnostic memory: optional
<p>Error during writing of the internal permanent memory.</p> <ul style="list-style-type: none"> • Execute the last operation again. • Check the following: Is an error present that can be reset first? When downloading a parameter file, check if the version of the parameter file fits the firmware. If the error occurs again, please contact Festo Service. <p>– Resettable: Error can be reset immediately. Definable error response(s): F, G</p>		
28h	Homing required	Can be parameterised as: F /W/- Diagnostic memory: optional
<p>A valid reference travel has not yet been conducted. The drive is no longer referenced (e.g. as a result of a logic power failure or because the homing method or axis zero point has been changed).</p> <ul style="list-style-type: none"> • Perform homing or repeat the last homing if it was not completed successfully. <p>– If parameterised as an error: Error can be reset immediately. Parameterisable error response(s): B, C, D, E, F, G</p> <p>– For parameterisation as a warning: The warning disappears if the homing run has been completed successfully.</p>		
29h	Target position behind negative software limit	Can be parameterised as: F /-/ - Diagnostic memory: optional
<p>The start of a positioning task was suppressed because the target lies behind the negative software limit position.</p> <ul style="list-style-type: none"> • Check target data. • Check positioning area. • Check position set type (absolute/relative?). <p>– Resettable: Error can be reset immediately. Definable error response(s): B, C, E, F</p>		

Diagnostic messages and fault clearance		
2Ah	Target position behind positive software limit	Can be parameterised as: F/-/- Diagnostic memory: optional
<p>The start of a positioning task was suppressed because the target lies behind the positive software limit position.</p> <ul style="list-style-type: none"> • Check target data. • Check positioning area. • Check position set type (absolute/relative?). <p>– Resettable: Error can be reset immediately. Definable error response(s): B, C, E, F</p>		
2Bh	Firmware update, invalid firmware	Can be parameterised as: F/W/- Diagnostic memory: optional
<p>The firmware update process could not be performed. The firmware version is incompatible with the hardware used.</p> <ul style="list-style-type: none"> • Determine the version of the hardware. You can ascertain the compatible firmware designs and download the appropriate firmware from the Festo website. <p>– If parameterised as an error: Error can be reset immediately. Parameterisable error response(s): A</p> <p>– For parameterisation as a warning: The warning disappears if a new FW download process is started.</p>		
2Ch	FHPP incorrect record number	Definable as: F/W/I Diagnostic memory: optional
<p>An attempt has been made to start a record with an invalid record number.</p> <ul style="list-style-type: none"> • Select a new record with a valid record number. <p>– If defined as an error: Error can be reset immediately. Definable error response(s): F, G</p> <p>– If defined as a warning: The warning disappears when a record with a valid record number is started.</p>		
2Dh	I²t warning motor	Can be parameterised as: -/W/I Diagnostic memory: optional
<p>The I²t warning limit for the motor is reached.</p> <ul style="list-style-type: none"> • Parameterise message as a warning or suppress completely as information. <p>– If parameterised as a warning: The warning disappears when the I²t integral falls below 80 %.</p>		
2Eh	Index pulse too close on proximity sensor	Can be parameterised as: F/-/- Diagnostic memory: optional
<p>The switching point of the proximity sensor is too close to the index pulse. This can in some cases mean that no reproducible reference position can be determined.</p> <ul style="list-style-type: none"> • Move reference switch/limit switch to the axis. You can display the distance between the switch and index pulse in the FCT. <p>– Resettable: Error can be reset immediately. Definable error response(s): B, C, E, F</p>		

Diagnostic messages and fault clearance		
2Fh	Following error	Can be parameterised as: F/W/I Diagnostic memory: optional
<p>The following error has become too great. This error can occur during positioning and speed modes.</p> <ul style="list-style-type: none"> • Enlarge error window. • Acceleration, speed, jerk or load too great? Mechanics stiff? • Motor overloaded (current limitation from I²t monitoring active?) <p>– If parameterised as an error: The error can only be reset after the cause is eliminated. Definable error response(s): B, C, E, F</p> <p>– For parameterisation as a warning: The warning disappears if the following error is back within the permissible range.</p>		
30h	Braking resistor	Can be parameterised as: F/W/I Diagnostic memory: always
<p>No braking resistor is connected.</p> <ul style="list-style-type: none"> • Check whether a braking resistor is required for the application. This is especially the case if the error 1Ah “Intermediate circuit voltage exceeded” appears. • If this message appears even though a braking resistor is connected, check the lines for wire break. • If no braking resistor is needed, the message can be suppressed with “Ignore”. <p>– If parameterised as an error: The error can only be reset after the cause is eliminated. Parameterisable error response(s): A</p> <p>– If parameterised as a warning: The warning disappears when a braking resistor is connected.</p>		
32h	FCT connection with master control	Can be parameterised as: F/-/I Diagnostic memory: optional
<p>Connection to the FCT has been interrupted.</p> <ul style="list-style-type: none"> • Check the connection and perform a reset, if necessary. <p>– Resettable: Error can be reset immediately. Definable error response(s): B, C, D, E, F, G</p>		
33h	Output stage temperature warning	Can be parameterised as: -/W/I Diagnostic memory: optional
<p>Temperature of output stage increased.</p> <ul style="list-style-type: none"> • Check cylinder sizing. • Check motor and cabling for short circuits. • Check the mechanics for sluggishness. • Reduce the ambient temperature; take output derating into account; improve heat dissipation. <p>– If parameterised as a warning: The warning disappears when the temperature is back below the danger threshold.</p>		

Diagnostic messages and fault clearance		
34h	Safe Torque Off (STO)	Can be parameterised as: F/W/I Diagnostic memory: optional
<p>The “Safe Torque Off” safety function has been requested.</p> <ul style="list-style-type: none"> Observe the separate documentation for the STO function. If parameterised as an error: The error can only be reset after the cause is eliminated. Definable error response(s): 0 For parameterisation as a warning: The warning disappears if the STO is no longer requested. 		
37h	Standstill monitoring	Can be parameterised as: -/W/I Diagnostic memory: optional
<p>The actual position is outside the downtime window. Parameterisation of the window may be too narrow.</p> <ul style="list-style-type: none"> Check parameterisation of the downtime window. If parameterised as a warning: The warning disappears when the actual position is within the standstill window again or a new record has been started. 		
38h	Parameter file access	Can be parameterised as: F/-/- Diagnostic memory: optional
<p>During a parameter file procedure all other reading and writing routines for the parameter file are blocked.</p> <ul style="list-style-type: none"> Wait until the process is complete. The time between 2 parameter file downloads should not be less than 3 s. Resettable: Error can only be reset after the cause of the error has been eliminated. Definable error response(s): F, G 		
39h	Trace warning	Can be parameterised as: -/W/- Diagnostic memory: optional
<p>An error has occurred during trace recording.</p> <ul style="list-style-type: none"> Start a new trace recording. For parameterisation as a warning: The warning disappears if a new trace has been started. 		
3Dh	Start-up event	Can be parameterised as: -/-/- Diagnostic memory: always
<p>The device has been switched on or was switched on for longer than 48 days. This event also occurs when deleting the diagnostic memory. The start-up event does not occur if the preceding entry in the diagnostic memory has already been a start-up event.</p> <ul style="list-style-type: none"> This event is used only for better documentation of the diagnostic messages that occurred. 		
3Eh	Diagnostic memory	Can be parameterised as: F/-/- Diagnostic memory: always
<p>An error has occurred when writing or reading from the diagnostic memory.</p> <ul style="list-style-type: none"> Reset error. If the error is still present, it means a memory module is probably defective or an incorrect entry has been stored. Clear diagnostic memory. If the error is still present, the device needs to be replaced. Resettable: Error can be reset immediately. Definable error response(s): F, G 		

Diagnostic messages and fault clearance		
3Fh	Record invalid	Can be parameterised as: F/-/- Diagnostic memory: optional
<p>The started record is invalid. The record data is implausible or the record type is invalid.</p> <ul style="list-style-type: none"> • Check parameters of the record. – Resettable: Error can be reset immediately. Definable error response(s): B, C, D, E, F, G 		
40h	Last teaching not successful	Can be parameterised as: -/W/l Diagnostic memory: optional
<p>Teaching of the current positioning record is not possible.</p> <ul style="list-style-type: none"> • The current positioning record must be of the type 'position record'. – If parameterised as a warning: The warning disappears if the following TEACH attempt is successful or a switch takes place from the Teach mode (mode 1) to normal operation (mode 0). 		
41h	System reset	Can be parameterised as: F/-/- Diagnostic memory: always
<p>An internal firmware error has been detected.</p> <ul style="list-style-type: none"> • Contact Festo repair service. – Resettable: Error can be reset immediately. Definable error response(s): A 		
43h	FCT connection without master control	Can be parameterised as: -/W/l Diagnostic memory: optional
<p>There is no longer a connection to the FCT, e.g. the cable was disconnected.</p> <ul style="list-style-type: none"> • Check the connection and perform a reset, if necessary. – For parameterisation as a warning: The warning disappears if the connection to the FCT is re-established. 		
44h	Parameter file not compatible with firmware	Can be parameterised as: -/W/l Diagnostic memory: always
<p>The parameter file that was just written to the device is not suitable for the firmware of that device. As much data as possible is automatically taken over from the parameter file. Parameters that are not initialised through the parameter file are imported from the default parameter file. If new firmware software is required, all parameters might not be written.</p> <ul style="list-style-type: none"> • Load a valid parameter file into the device. – If parameterised as a warning: The warning disappears when a new parameter file is successfully written. 		

Diagnostic messages and fault clearance		
47h	Modbus® connection with master control	Definable as: F/-/- Diagnostic memory: optional
<p>The Modbus® connection to the controller has been interrupted.</p> <ul style="list-style-type: none"> • Check the connection and perform a reset. – Resettable: Error can be reset immediately. Definable error reaction(s): B, C, D, E, F, G – For parameterisation as a warning: The warning disappears if the connection to the controller is re-established. 		
48h	Modbus® connection without master control	Definable as: -/W/I Diagnostic memory: optional
<p>There is no longer a connection to the controller, e.g. the cable was disconnected.</p> <ul style="list-style-type: none"> • Check the connection and perform a reset. – For parameterisation as a warning: The warning disappears if the connection to the controller is re-established. 		
4Ah	Safe Torque Off (STO) discrepancy time	Can be parameterised as: F/W/I Diagnostic memory: optional
<p>Control signals STO1 and STO2 did not occur concurrently or are wired opposite to each other.</p> <ul style="list-style-type: none"> • Check discrepancy time. Assure both control signals are wired in the same direction and maintain discrepancy time. – If parameterised as an error: Error can be reset immediately. Definable error response(s): 0 – For parameterisation as a warning: The warning disappears if the STO is no longer requested. 		
4Ch	Value is out of range	Definable as: F/-/- Diagnostic memory: optional
<p>The object value could not be written because the value lies outside the permitted range of values.</p> <ul style="list-style-type: none"> • Write the object again, taking due account of the permitted range of values. – Resettable: Error can be reset immediately. Definable error response(s): B, C, D, E, F, G 		
4Dh	Bootloader memory error	Can be parameterised as: F/-/- Diagnostic memory: always
<p>In the boot procedure, a defective memory cell was detected.</p> <ul style="list-style-type: none"> • Perform a firmware update. If the error is still present, the memory might be faulty. Then the device must be replaced. – Resettable: Cannot be reset, software reset is necessary. Definable error response(s): A 		

Diagnostic messages and fault clearance		
4Eh	Overload 24V Outputs	Can be parameterised as: F/-/- Diagnostic memory: always
<p>A short circuit or overload has occurred to an external 24-V supply voltage of the device.</p> <ul style="list-style-type: none"> • Check wiring of the STO interface, reference switch and digital inputs and outputs. – Acknowledgement option: Error can only be acknowledged after eliminating the cause. Definable error response(s): A, B 		
4Fh	System information	Can be parameterised as: -/-/. Diagnostic memory: always
<p>A device-specific system event has occurred.</p> <ul style="list-style-type: none"> • This event is used for extended diagnostics. 		

6.4 Problems with the Ethernet connection

In the event of problems with the Ethernet connection, the IP configuration of the EMCA and the IP configuration of your PC are presumably not correctly adjusted to each other. FCT enables the following:

- Search for the EMCA device in the network
- Determination and change of the IP configuration

Determining and changing IP configuration of the device – with the FCT

1. In the [Component] menu of the FCT plug-in, select the command [FCT Interface], button “Scan...”. Then the devices found in the network are displayed.
2. In the context menu for the found device, select the command [Network]. Then the “Network properties” dialogue is displayed. With this dialogue, the IP configuration can be determined and changed (possible settings → Tab. 2.45).

Determine the IP configuration of the PC and change it - with Windows (e.g. Windows 7)

1. Select the command [Start] [System control] [Network and Internet] [Network and Release Centre] [Local Area Connection].
2. In the “Status” dialogue of [Local Area Connection], select the command [Properties].
3. Mark in the following dialogue window [Internet protocol Version 4].
4. Select the command “Properties”. Then, in the “Properties of Internet protocol version 4”, the IP configuration of the corresponding Ethernet interface of the PC is displayed.
5. Set an IP configuration suitable for the EMCA (→ Following example).

Example: Matching IP configurations to suit one another

The factory-setting IP configuration is particularly well suited for a direct connection. From the factory, the DHCP server of the device is active (→ Tab. 2.45). In this case, the device has a permanently parameterised IP configuration (IP address 192.168.178.1; subnet mask: 255.255.255.0).

To match the PC to the factory setting, select for the PC the setting [Source the IP address automatically] or set an appropriate fixed IP configuration (e.g. IP address 192.168.178.110; subnet mask: 255.255.255.0; Standard gateway: – (no address)).

Check the network settings of the PC – with Windows (example Windows 7)

1. Select the command [Start] [(All)Programs] [Accessories] [Input Request].
2. Enter the command `ipconfig` or `ipconfig /all`.
3. Check whether the devices are accessible in the same subnet. Contact your network administrator, if necessary.

The command `Ping` can be used to determine if the device can be reached in the network.

1. Select the command [Start] [(All)Programs] [Accessories] [Input Request].
2. Enter the following command line: `ping 192.168.178.1` (IP address of the device from the factory)

6.5 Other problems and remedies

Problem	Cause	Remedy
The EMCA is not working.	The EMCA is connected incorrectly.	<ul style="list-style-type: none"> • Check all cables and connections for short circuits, open circuits or incorrect pin allocation.
	Defective cable	<ul style="list-style-type: none"> • Observe the instructions in the assembly instructions for the cables and plugs used.
	Burned-through internal fuse (internal short circuit)	<ul style="list-style-type: none"> • Replace EMCA.
The EMCA does not achieve the specified performance data.	Incorrect control signals from the higher-order controller	<ul style="list-style-type: none"> • Check control program.
	The controller is incorrectly set.	<ul style="list-style-type: none"> • Check controller parameters. • Observe the information in the Help of the FCT plug-in to correctly set the controller parameters.
	Error in the power supply	<ul style="list-style-type: none"> • Comply with voltage tolerances in accordance with Technical Data chapter.

Tab. 6.9 Other problems and remedies

7 Maintenance, care, repair and replacement

7.1 Maintenance and care



Warning

Rapidly rotating motor shaft with high torque.

Clothing, jewellery and hair can be caught and wrapped around the shaft. People can be injured as a result.

- Make sure that clothing, jewellery or hair **cannot** be caught by the rotating motor shaft.
- Ensure that clothing fits tightly.
- Hair nets must be worn with long hair.



Warning

Danger of burns from hot housing surfaces.

Contact with the motor housing can cause burn injuries. This can frighten people and cause them to act in an unpredictable manner. This can lead to other forms of secondary damage.



- Make sure that unintentional contact is not possible.
- Inform operating and maintenance staff about the possible hazards.



Note

Gas formation with fire risk.

If cleaning agents make contact with the hot surface of the motor, gases can form and ignite.

- Prior to cleaning work, let the drive cool down to room temperature.
- Pay attention to the instructions for use of the cleaning agent.



Caution

Uncontrolled drive motion may cause personal injury and material damage.

Before carrying out mounting, installation and maintenance work:

- Switch off power supplies.
- Secure the power supplies against accidental reactivation.



Caution

Rapidly rotating motor shaft with high torque.

Contact with the motor shaft can cause burn injuries and abrasions.

- Ensure that the rotating motor shaft and components attached to it cannot be touched.

EMCA-EC-67-...-1TM... with external battery (multi-turn absolute measurement system)

The battery is **not** charged when the supply voltage is switched on.

- Check status of the battery at appropriate intervals.
- Replace discharged battery early enough.

Regarding care:

- Clean the outside of the product with a soft cloth.

EMCA-EC-67-... without external battery

If used as intended, the product is maintenance-free.

Regarding care:

- Clean the outside of the product with a soft cloth.

7.2 Disassembly



Note

Loss of the parameter file

The parameters of the device are reset to factory settings after repair or replacement (new devices).

- Before replacement or repair of the device, read it out with the web server or FCT and save it (upload).
- After mounting the new or repaired device, download the parameter file into the device with the web server or FCT.

Disassemble in reverse order of installation (→ Chapter 3).

To disconnect the connections [X4] to [X10], the cover of the device must be removed. Other components of the device must **not** be disassembled.

Before dismantling

1. Ensure that there is no voltage.
2. Ensure the system cannot be switched back on.
3. Remove the cover of the connection box with an Allen key – width across flats (SW) 2.5 mm.
4. Remove cover carefully.
5. Disconnect all electrical lines.
6. Seal cable throughfeeds (e.g. with blind seals).
7. Place cover on the connection box and screw it tight – tightening torque 1.5 Nm.

Disassembly



Note

Excessive axial forces on the motor shaft can damage the motor.

- Do not apply axial forces to the motor shaft of the device.

1. Loosen the 4 mounting screws between the motor and additional components.
2. Disconnect device from the driven mechanical components.

7.3 Repair



Repair or maintenance of the product is not permissible. If necessary, replace the complete product.

7.4 Replacement and disposal

- Observe the instructions on dismantling in chapter 7.2.

7.4.1 Disposal



Observe the local regulations for environmentally friendly disposal of electronic modules. The product is RoHS-compliant. The material used in the packaging has been specifically chosen for its recyclability.

A Technical appendix

A.1 Technical data

A.1.1 General technical data

General technical data	EMCA-EC-67-...
Type name code	EMCA
Type of mounting	<ul style="list-style-type: none"> – Screw-clamped – With through-hole
Assembly position	Any
Controller operating mode	PWM MOSFET power output stage Cascade controller with <ul style="list-style-type: none"> – P position controller – PI speed controller – PI current controller
Parameterisation interface	Ethernet
Ethernet, supported protocols	TCP/IP, Modbus [®] TCP (FHPP)
Control interface	Digital I/O interface
	Modbus [®] TCP
Communication profile	FHPP
Protective functions	<ul style="list-style-type: none"> – I²t monitoring – Temperature monitoring – Current monitoring – Voltage failure detection – Following error monitoring – Software end-position detection
Temperature monitoring	<ul style="list-style-type: none"> – Silicon absolute temperature sensor – Automatic switch-off in event of over-temperature

Tab. A.1 Technical data: general

A.1.2 Product conformity and certifications

Product conformity and certifications	EMCA-EC-67-...
CE marking (declaration of conformity → www.festo.com/sp)	In accordance with EU Machinery Directive 2006/42/EC
	in accordance with EU EMC Directive 2014/30/EU ¹⁾
Additional certifications	RCM mark ²⁾ c UL us - Recognised (OL) ²⁾

1) The component is intended for industrial use. Outside of industrial environments, e.g. in commercial and mixed-residential areas, actions to suppress interference may have to be taken.

2) Only valid for product variants with corresponding marking

Tab. A.2 Technical data: product conformity and certifications

A.1.3 Mechanical data

Dimensions and weight		EMCA-EC-67-S-...	EMCA-EC-67-M-...
Dimensions (H*W*D)		→ Section 3.1	
Product weight			
EMCA without holding brake [B]	[g]	1900	2260
and without multi-turn absolute measurement system [M]			
Option multi-turn absolute measurement system [M]	[g]	25	
Option holding brake [B]	[g]	350	

Tab. A.3 Technical data: general

A.1.4 Operating and environmental conditions

Operating and environmental conditions		EMCA-EC-67-...
Ambient temperature		
At nominal power	[°C]	0 ... +20
With power reduction of 1.75 % per °C:	[°C]	20 ... 50
Storage temperature	[°C]	-25 ... +70
Relative air humidity at 25 °C	[%]	0 ... 95 (non-condensing)
Degree of protection		
EMCA-... (without S1)		IP54
EMCA-...-S1		IP65; motor shaft IP54
Vibration and shock resistance (in accordance with DIN EN 60068) ¹⁾		
Transport		3.5 mm path at 2 ... 9 Hz; 1 g acceleration at 9 ... 200 Hz
– Vibration (part 2-6)		Severity level ¹⁾ 2
– Shock (part 2-27)		Severity level ¹⁾ 2
– Continuous shock (part 2-29)		-

1) Explanation of the severity level → table "Explanation of vibration and shock – severity level"

Tab. A.4 Technical data: operation and ambient conditions

Explanation of vibration and shock – severity level

Vibration load					
Frequency range [Hz]		Acceleration [m/s^2]		Deflection [mm]	
Severity level 1	SL2	SL1	SL2	SL1	SL2
2 ... 8	2 ... 8	–	–	±3.5	±3.5
8 ... 27	8 ... 27	10	10	–	–
27 ... 58	27 ... 60	–	–	±0.15	±0.35
58 ... 160	60 ... 160	20	50	–	–
160 ... 200	160 ... 200	10	10	–	–

Shock load					
Acceleration [m/s^2]		Duration [ms]		Shocks per direction	
SL1	SL2	SL1	SL2	SL1	SL2
±150	±300	11	11	5	5

Continuous shock load					
Acceleration [m/s^2]		Duration [ms]		Shocks per direction	
±150		6		1000	

A.1.5 Data on the integrated motor

Motor data		EMCA-EC-67-S-...	EMCA-EC-67-M-...
Nominal power	[W]	120	150
Nominal torque	[Nm]	0.37	0.45
Nominal speed	[rpm]	3100	3150
Maximum speed	[rpm]	3500	3300
Mass moment of inertia of rotor	[kg cm ²]	0.175	0.301
Perm. axial shaft load	[N]	60	60
Perm. radial shaft load	[N]	100	100

Tab. A.5 Motor data

A.1.6 Data on the integrated rotary position encoder

Rotary position encoder		EMCA-EC-67-...-1TE...	EMCA-EC-67-...-1TM...
Rotary position encoder		Absolute single turn encoder	Absolute multi-turn encoder
Rotary position encoder measuring principle		Magnetic	
Resolution	[bit]	12 (4096 increments per revolution)	
	[°]	Approx. 0.088	
Absolute encoder operating duration (at medium ambient temperature)			
Without external battery		-	7 days
With external battery			6 months
Duration of charge until the storage duration without external battery is reached	[h]		24

Tab. A.6 Encoder data

A.1.7 Holding brake (only EMCA-EC-...-...-B)

Holding brake (optional)		EMCA-EC-67-...-...B
Brake holding torque ¹⁾	[Nm]	1
Brake power consumption	[W]	9
Mass moment of inertia, brake	[kg cm ²]	0.021

1) Nominal values after run-in period at plant. Prolonged periods without operation (e.g. storage) can reduce these values, for example, as a result of settling processes. This effect can be eliminated through repeated operation at low rotational speed.

Tab. A.7 Holding brake (optional)

A.1.8 Ethernet interface [X1]

Ethernet		EMCA-EC-67-...
Connection design		Plug connector M12, 5-pin, D-coded
Max. transmission rate	[Mbit/s]	100
Supported protocols		TCP/IP

Tab. A.8 Connection data: Ethernet interface [X1]

A.1.9 Power supply [X4]

Power supply [X4]		EMCA-EC-67-S-...	EMCA-EC-67-M-...
Cabling			
Max. cable length	[m]	$l \leq 30$	
Cable specification		→ Tab. 4.5	
Logic and load supply			
Nominal voltage	[V DC]	24	
Perm. voltage fluctuations	[%]	±20	
Nominal current	[A]	6.9	7.2
Peak current	[A]	10.2	10.3
Protection against electric shock		PELV circuit (Protected Extra-Low Voltage)	

Tab. A.9 Connection data: power supply [X4]

A.1.10 Braking resistor [X5]

Braking resistor [X5]		EMCA-EC-67-S-...	EMCA-EC-67-M-...
Connection for external braking resistor, e.g. CACR-LE2-6-W60			
Max. cable length	[m]	$l < 3$	
Braking resistor, external	[Ω]	6	

Tab. A.10 Technical data: braking resistor [X5]

A.1.11 STO interface [X6]



Technical data for STO interfaces [X6] → Description of STO safety function, GDCE-EMCA-EC-S1-....

A.1.12 Reference or limit switch [X7], [X8]

Reference or limit switch [X7], [X8]		EMCA-EC-67-...
Max. cable length	[m]	$l < 3$
Cable specification		→ Tab. 4.5
Logic auxiliary supply		
Nominal voltage	[V DC]	24
– Supply via [X9]		
– Not additionally filtered or stabilised		
Maximum current	[mA]	100
Overload protection		No overload protection Only use for switching the digital inputs
Digital inputs		
Work range of logic input	[V DC]	24
Switching logic		Configurable
Characteristics		Galvanically connected to logic potential
Specification		Based on IEC 61131-2

Tab. A.11 Reference or limit switch [X7], [X8]

A.1.13 I/O interface [X9]

I/O interface [X9]		EMCA-EC-67-...
Max. cable length	[m]	l < 30
Cable specification		→ Tab. 4.5
Logic auxiliary supply		
Nominal voltage	[V DC]	24
<ul style="list-style-type: none"> – Supply via [X9] – Not additionally filtered or stabilised 		
Maximum current	[mA]	100
Overload protection		No overload protection Only use for switching the digital inputs
Digital inputs		
Number of digital logic inputs		11
Work range of logic input	[V DC]	24
Switching logic		PNP (positive switching)
Characteristics		Galvanically connected to logic potential
Specification		Based on IEC 61131-2
Digital outputs		
Number of digital logic outputs		4
Characteristics of digital logic outputs		Freely configurable in some cases Not galvanically isolated
Maximum peak current for digital outputs	[mA]	100
Switching logic		PNP (positive switching)

Tab. A.12 Technical data: I/O interface [X9]

A.1.14 Connection for external battery [X10] (only EMCA-EC-67-...-1TM)

Connection for external battery [X10]		EMCA-EC-67-...
Max. cable length	[m]	≤ 3
Cable specification		→ Tab. 4.5
Voltage	[V DC]	9

Tab. A.13 Connection for external battery [X10]

A.1.15 Materials

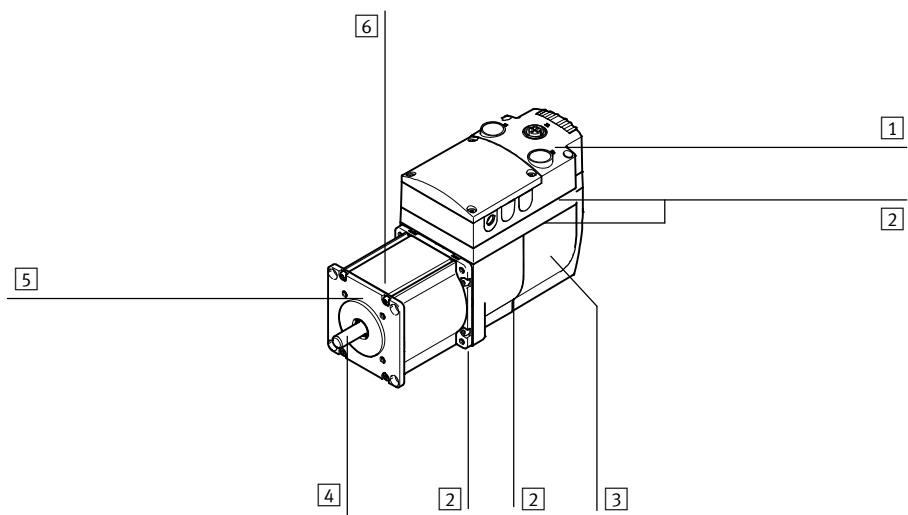

Materials	EMCA-EC-67-...
Housing	
- Connection box [1]	Polymer
- Lower housing part (power electronics) [3]	Die-cast zinc
Seal [2]	NBR
Motor	
- Shaft [4]	Steel
- Flange [5]	Die-cast zinc
- Housing profile [6]	Aluminium
Note on materials	- Contains paint-wetting impairment substances

Tab. A.14 Technical data: materials

B Glossary

Term/abbreviation	Description
AZ (= Axis Zero point)	Axis zero point → Chapter 2.4.1
DIN	Digital input
DOUT	Digital output
EMC	Electromagnetic compatibility
FCT	Parameterisation and commissioning software (FCT = Festo Configuration Tool)
Following error	The deviation between the setpoint position (in accordance with the pre-calculated course of the path) and the actual position is calculated during the execution of a positioning record. This deviation is designated a following error.
Homing	Overview of the dimension reference system → Chapter 2.4.1
I/O	Input/output
Jog mode	Manual control of the drive → Chapter 2.4.3
MC	Motion Complete (Target recognition)
PLC/IPC	Programmable logic controller/industrial PC
PZ (= project zero point)	Project zero point → Chapter 2.4.1
REF (= REference point)	Reference point → Chapter 2.4.1
Reference switch	Proximity sensor for defining the reference point
Software end position	Overview of the dimension reference system → Chapter 2.4.1
Teaching	Transfer of the current position as a parameter → Chapter 2.4.4

Tab. B.1 Product-specific terms and abbreviations

Index

- A**
- Acknowledge error 78
 - Axis zero point 23, 24
- B**
- Battery 102
 - Brake chopper 61
 - Braking resistor 98
 - External 151
- C**
- Cable lengths 90
 - Cable specifications 93
 - Commissioning steps 115
 - Comparators 54
 - Control section and connections 20
 - Crimp contact 93
 - Crimp pliers 93
- D**
- Data matrix code 8
 - DHCP server 64
 - Diagnostic memory 63, 123
 - Diagnostic messages 127
 - Dimension reference system 23, 24
 - Dimensions 86
 - Direction of rotation 23
 - Disposal 146
 - Documentation 7
 - Drive functions 22
- E**
- EMC 155
 - Cabling 90
 - Screening 90
 - EMC-compliant wiring 90
 - Error management 62
 - Error responses 127
 - Errors 62
 - Ethernet interface 91
- F**
- Factory setting 106
 - Fault clearance 128
 - FCT 8, 19, 155
 - Festo Configuration Tool 19, 155
 - Firmware 8
 - Flash memory 122
 - Flying measurement 70
 - Following error 54, 56
 - Force comparator 60
 - Force/torque mode 44, 45
 - Free run-out 62
- H**
- Holding brake 85, 150
 - Homing 22, 26, 79
 - Homing methods 28
- I**
- I²t monitoring 61
 - Index evaluation 26
 - Information 62
 - Intermediate stop 46
 - IP configuration 107, 142
- J**
- Jog mode 22
 - Jog/teach (mode 1) 74
 - Jogging 35, 80
- L**
- LED 125
 - Limit or reference switch 100
 - Limit switch 25
 - Line lengths 90
 - Load parameter file 116
 - Loading firmware 106

M

Master control	111
Materials	154
Message	
– Following error	56
– Motion complete	55
– Standstill monitoring	57
Modbus® TCP	65
Mode 0/1	76
Motion complete	54
Motor current	61
Mounting	88

N

Network connection	108
Normal operation (mode 0)	73

O

Optimise controller setting	119
-----------------------------------	-----

P

Password protection	109
PLC	155
Plug connector	93
Position comparator	59
Positioning mode	37
Product key	8
Product label	8
Project zero point	23, 24
Protective functions	61

Q

Quick stop	46, 62
------------------	--------

R

Record deceleration	62
Record selection for jog/teach	74
Record selection in normal operation	73
Reference point	23, 24
Reference switch	100
Repair	146

S

Safety function	116
Safety instructions	11
Screening	90
Seal inserts	94
Serial number	8
Set linking	52
Software end position	25
Speed comparator	59
Speed mode	40
Standstill monitoring	54, 57
Start record	81
STO (safe torque off)	99
Stroke limit	41

T

Teaching	80
Technical data	147
Temperature monitoring	61
Time comparator	60
Transport and storage conditions	13

U

Use for intended purpose	12
--------------------------------	----

V

Version	8
Voltage monitoring	61

W

Warning	62
Web server	19, 112, 113

Y

Year of manufacture	8
---------------------------	---

Copyright:
Festo AG & Co. KG
Ruiter Straße 82
73734 Esslingen
Germany

Phone:
+49 711 347-0

Fax:
+49 711 347-2144

Reproduction, distribution or sale of this document or communication of its contents to others without express authorization is prohibited. Offenders will be liable for damages. All rights reserved in the event that a patent, utility model or design patent is registered.

E-mail:
service_international@festo.com

Internet:
www.festo.com