

Spindle axis ELGC-BS and toothed belt axis ELGC-TB

FESTO

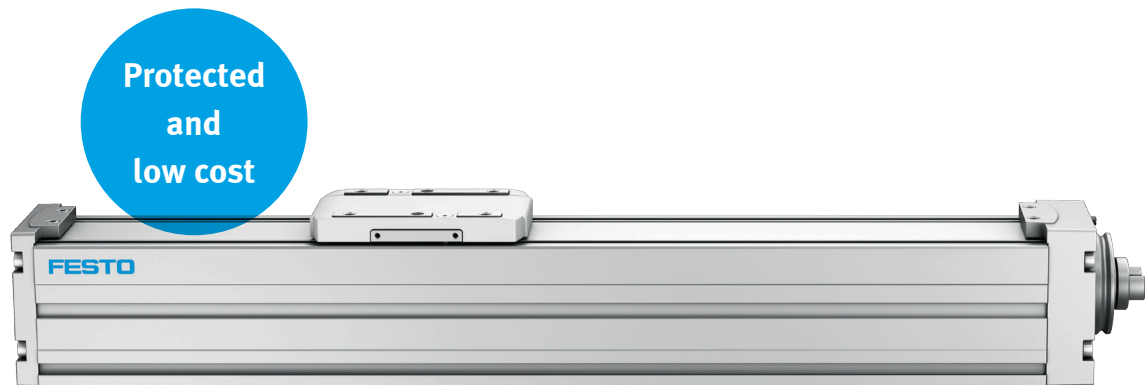

Compact movement!

Highlights

- Compact: optimum ratio of installation space to working space
- Protected: internal guide keeping external influences out
- Flexible: wide range of motor mounting options for optimum machine integration
- Unique: "one-size-down" mounting system

When it comes to compact dimensions and optimised installation space, the low-cost axis series ELGC is ideal. These features are a clear advantage in assembly systems, test and inspection systems, small parts handling, the electronics industry and desktop applications. The spindle and toothed belt axes are suitable for all horizontal and vertical movements, and are the perfect complement to the guide axis ELFC or the mini slide EGSC.

Powerful and clean

Precise, capable of carrying heavy loads and very durable, the linear axes ELGC have an internal, protected recirculating ball bearing guide and life-time lubrication. The weight-optimised design and smooth, clean look surfaces create handling systems that are fit to be seen. Flexible motor mounting is included as standard.

Optimum protection

The magnetic, stainless steel band provides a tight seal and doesn't sag in inverted installations.

Spindle axis ELGC-BS-KF

Internal spindle with ball screw for precise and smooth operation.

Toothed belt axis ELGC-TB-KF

Internal toothed belt drive for dynamic movements, even with heavy loads.

Guide axis ELFC-KF

Driveless linear guide axis with freely movable slide and recirculating ball bearing guide. Ideal for supporting force and torque as well as for increased torsional resistance and reduced vibrations.

Spindle axis ELGC-BS and toothed belt axis ELGC-TB

Spindle axis ELGC-BS-KF

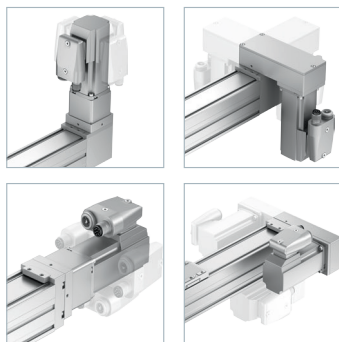

Flexible motor mounting,
position can be changed at any
time

Stainless steel cover band
kept in place with magne-
tic strips

Compact double bearing
integrated in the axis to save space

Toothed belt axis ELGC-TB-KF

Recirculating ball bearing guide

- Integrated recirculating ball bearing guide with long service life
- Rigid and precise guide rail to absorb high guide forces

Compact, integrated
coupling, easy to service

Clean look design: easy to clean
and less prone to contamination

Vacuum connection

- Standard: closed in order to seal the axis and reduce particle emissions
- Optional: can be connected at any time for increased protection of the system

Technical data	Spindle axis ELGC-BS-KF	Toothed belt axis ELGC-TB-KF	Guide axis ELFC-KF
Design	Electromechanical axis with ball screw	Electromechanical axis with toothed belt	Guide without drive
Sizes	32, 45, 60, 80	45, 60, 80	32, 45, 60, 80
Working stroke [mm]	100 ... 1,000	200 ... 2,000	100 ... 2,000
Max. feed force [N]	40, 100, 200, 350	75, 120, 250	-
Max. speed [m/s]	1	1.5	1.5
Max. acceleration [m/s ²]	15	15	15

Simple and compact system

