

Semi-rotary drive

DRRD-12 ... 63

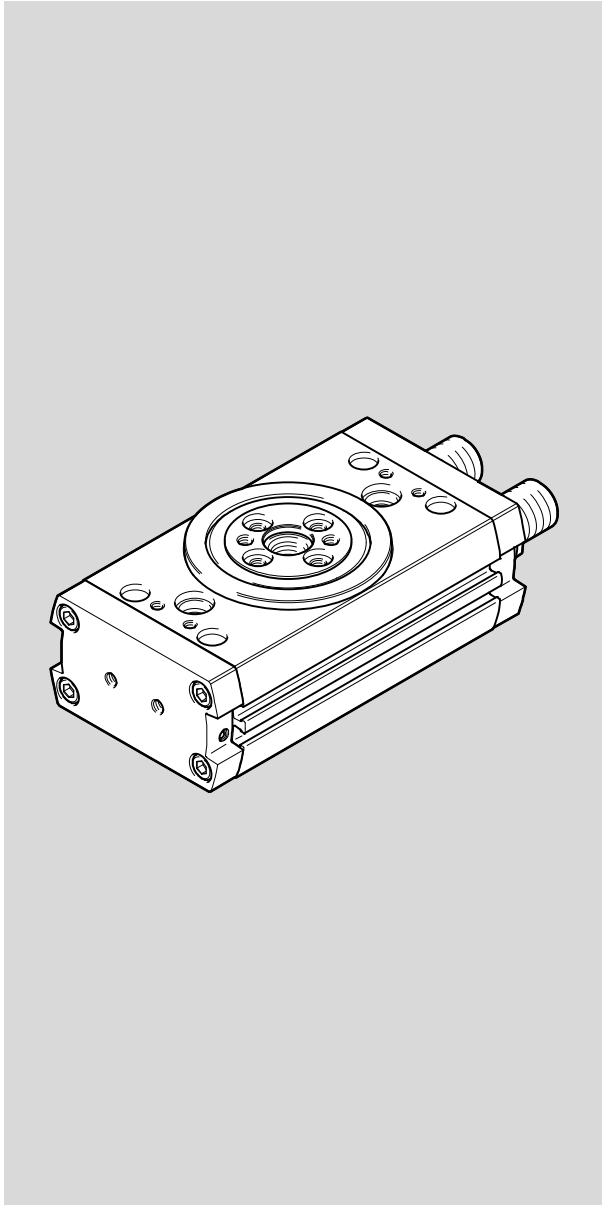

FESTO

en **Operating
instructions**

8074788
2017-10d
[8074790]

Original instructions

Symbols:



Warning

Installation and commissioning may only be performed in accordance with these instructions by technicians with appropriate qualifications.



Caution



Note



Environment



Accessories

English – Semi-rotary drive DRRD-12 ... 63

Table of contents

1	Control sections and connections	4
2	Function and application	5
3	Requirements for product use	6
4	Transport and storage	7
5	Installation	7
5.1	Mechanical installation	7
5.2	Pneumatic installation	9
5.3	Electrical installation	9
6	Commissioning	10
6.1	Commissioning end-position adjustment	10
6.2	Carrying out commissioning	12
7	Operation	13
8	Maintenance and care	14
9	Disassembly and repair	15
10	Accessories	16
11	Trouble-shooting	16
12	Technical data	17

Documentation on the product



For all available product documentation → www.festo.com/pk

1 Control sections and connections

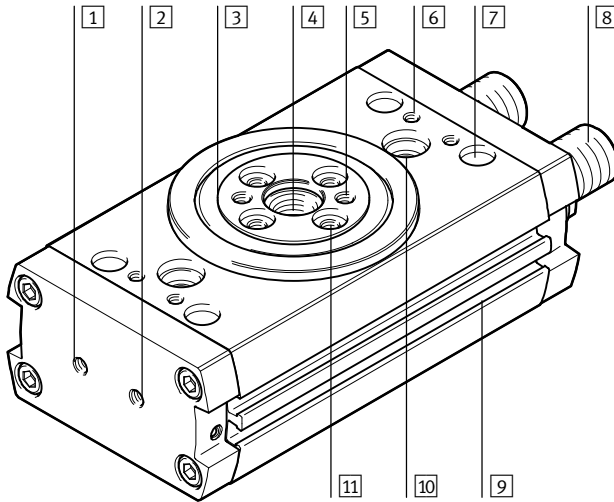

- | | |
|---|---|
| 1 Supply port (swivel clockwise) | 7 Centring hole for accessories |
| 2 Supply port (swivel anti-clockwise) | 8 Shock absorber for swivel angle adjustment, secured with lock nut (x2) |
| 3 Flanged shaft | 9 Slot for cylinder switch (2x for DRRD-12); (4x for DRRD-16 ...) 63) |
| 4 Shaft opening for guiding through cables/ compressed air tubing with centring hole | 10 Mounting interface DRRD (2x) |
| 5 Thread for accessories flange | 11 Mounting interface for payload (4x) |
| 6 Thread for accessories (e.g. for clamping unit and external shock absorbers) | |

Fig. 1

2 Function and application

The DRRD semi-rotary drive is a double-acting twin-piston drive. When the compressed air supply ports are pressurized reciprocally, two pistons arranged in parallel move in the opposite direction backwards and forwards. This linear motion is converted through pinions into a swivel motion of the drive shaft.

The end position cushioning is done:

- DRRD-...-P with flexible cushioning
- DRRD-...-Y9/Y10/Y14 with internal hydraulic shock absorbers
- DRRD-...-Y12 with external hydraulic shock absorbers (→ assembly instructions).

The DRRD semi-rotary drive is intended for swivelling effective loads which have to execute a defined angular movement.

3 Requirements for product use



Note

Malfunction and material damage due to incorrect handling.

- Always comply with the specifications of this chapter.
This is the only way to ensure correct and safe product behaviour.

- Take into consideration the legal regulations applicable for the destination, as well as:
 - regulations and standards
 - regulations of the testing organizations and insurers
 - national specifications.
- Note the warnings and instructions on the product and in the relevant operating instructions.
- Remove all transport packaging, such as transparencies, caps and cartons (with the exception of any covers in the pneumatic ports).
The packaging is intended for recycling (exception: oil paper = residual waste).
- Take into account the material specifications (→ 12 Technical data).
- Use the product in its original status, without any unauthorised product modifications.
- Take into consideration the ambient conditions at the location of use.
Corrosive elements in the environment (e.g. ozone) will reduce the service life of the product.
- Compare the limit values specified in these operating instructions with your actual application (e.g. pressures, forces, torques, temperatures, masses, speeds).
Operation of the product in compliance with the relevant safety regulations is contingent on adherence to the load limits.
- Take the tolerance of the tightening torques into account. Unless otherwise specified, the tolerance is $\pm 20\%$.
- Do not modify any screws or threaded pins unless this is directly requested in these instructions. For safety reasons, they are fixed with screw locking agent.

For vertical installation:

- Make sure the drive reaches a stable position when it comes to rest (e.g. the lowest point or a variant with clamping unit → 10 Accessories).
- Make sure the compressed air is properly prepared (→ 12 Technical data).
- Having selected a medium, stick with it for the entire life of the product (e.g. always use unlubricated compressed air).
- Pressurize your entire system slowly.
There will then be no uncontrolled movements.
For slow start-up pressurisation, use start-up valve type HEL.

4 Transport and storage

- Take into account the weight of the DRRD: It weighs up to 20 kg (→ 12 Technical data).

5 Installation

5.1 Mechanical installation



Note

- Handle the DRRD with care to prevent damage to the drive shaft. This applies in particular to the following points:

1. Position the DRRD so that you can easily reach the control sections and connections.
2. Secure the DRRD at the mounting interface 10 by using two screws and two centring sleeves each. The tightening torque is summarised in the following table (→ Tab. 1).

Direct mounting

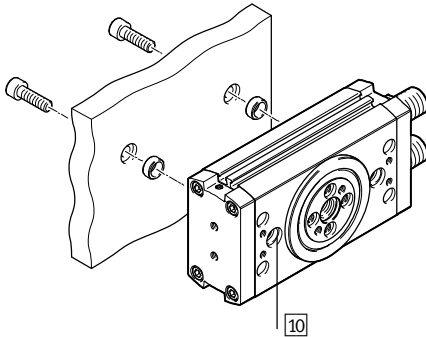

Through-hole fastening

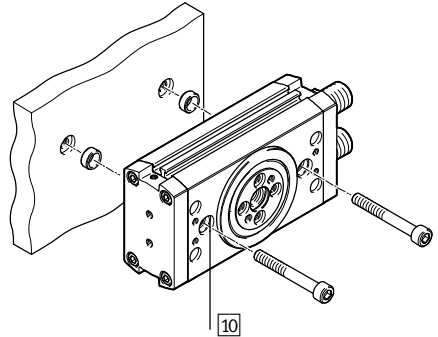

Fig. 2

Size	12	16	20	25	32	35	40	50	63
Screw (direct mounting)	M5	M5	M5	M6	M8	M8	M10	M10	M12
Tightening torque [Nm]	6	6	6	10	18	18	30	30	55
Screw (through-hole fastening)	M4	M4	M4	M5	M6	M6	M8	M8	M10
Tightening torque [Nm]	3	3	3	6	10	10	18	18	30
Centring sleeve ZBH [mm]	9	9	9	12	15	15	15	15	25

Tab. 1

3. Feed the appropriate lines through the hollow drive shaft, if necessary, or use the variant with energy throughfeed.

The shaft opening for wiring has the following dimensions (→ Tab. 2).

4. When mounting the moving mass, make sure that the following specifications are observed:

- installation without tilting
- permissible radial force F_y
- permissible axial force F_x
- permissible mass moment of inertia
- a structure that is as rotationally symmetrical as possible.

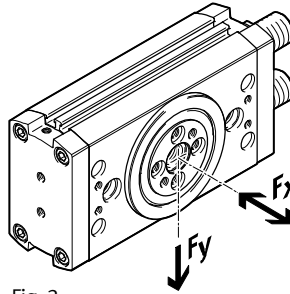

Fig. 3

The mass moment of inertia of the payload should be calculated. Lever arms, cantilevers and masses should be considered in the calculation (maximum permissible values → Catalogue specifications, www.festo.com/catalogue).



Note

If there are demanding requirements for concentricity of the components on the flanged shaft:

- Use the middle centring hole [4] as well as one of the 4 existing centring holes.

5. Secure the effective load to the drive flange at the mounting interface [11] by using at least two screws positioned opposite one another and centring sleeves.

The tightening torque is summarised in the following table (→ Tab. 2).

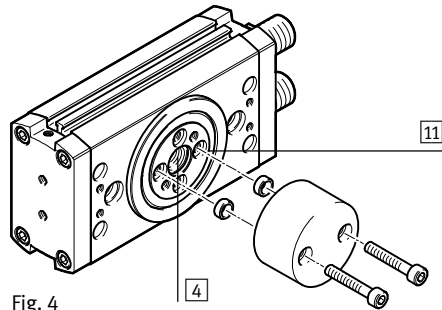

Fig. 4

Size		12	16	20	25	32	35	40	50	63
Shaft opening [4]	[mm]	5	8	8	10.5	10.5	10.5	21	21	21
Centring sleeve ZBH for middle centring hole	[mm]	7	12	12	15	15	25	25	25	25
Screw for thread at [11]		M3	M4	M4	M5	M6	M6	M6	M8	M10
Centring sleeve ZBH	[mm]	5	7	7	9	9	9	9	12	15
Tightening torque	[Nm]	1.2	3	3	6	10	10	10	20	40

Tab. 2

5.2 Pneumatic installation

- If necessary, remove the covers in the pneumatic ports.

To adjust the swivel speed:

- Use the GRLA one-way flow control valves. These are screwed directly into the compressed air supply ports.

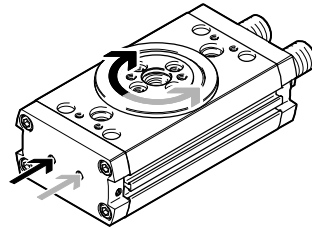

Fig. 5

For vertical installation and eccentric loads:

- Use the controlled check valve HGL or a compressed air spacer compensation reservoir VZS. In this way you can prevent the effective load from sliding down suddenly if there is a sudden pressure drop.

5.3 Electrical installation



Note

Multiple switching cycles of cylinder switches are possible, dependent on the design.

- Make sure the cylinder switches are always set to the first switching point. To do this, push the cylinder switch (A) in from the slot end where the piston to be sensed is located until the first switching occurs.

- Place the cylinder switches for sensing the end positions into the slots 9.

Sensing can be conducted with inductive proximity sensors with the help of the external sensing kit (➔ 10 Accessories).

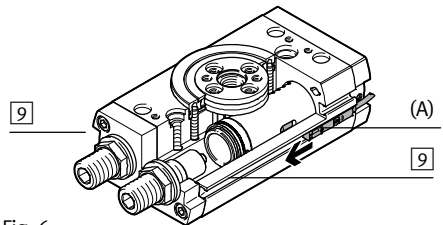

Fig. 6

6 Commissioning



Warning

Danger of injury from rotating loads.

- Make sure the DRRD is only set into motion with protective devices.
- Make sure that in the swivel angle of the DRRD
 - Nobody can reach in
 - No foreign objects can enter (e.g. by means of an individual protective guard).



Note

- Make sure that the following requirements are observed:
 - the shock absorbers are secured with lock nuts
 - the operating conditions are within the permissible ranges
 - the assembly instructions for the DRRD-...-Y12 are observed.

6.1 Commissioning end-position adjustment

1. Rotate both upstream one-way flow control valves (A):
 - at first completely closed
 - then open them again approximately one turn.
2. Pressurize the drive optionally in one of the following ways:
 - slow pressurisation of one side
 - simultaneous pressurisation of both sides with subsequent venting of one side.

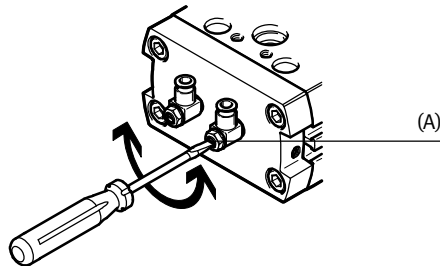

Fig. 7



Note

Risk of damage!

If the shock absorber is unscrewed too far, it will result in the piston colliding with the end cap with insufficient cushioning.

- Observe the permissible shock absorber settings (➔ Tab. 4).

3. Pressurize the corresponding port to swivel the DRRD into the desired end position.
4. Loosen the lock nut on the shock absorber.

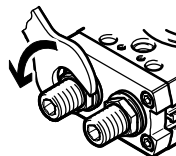

Fig. 8

- Turn the corresponding shock absorber until the desired end position adjustment has been reached.

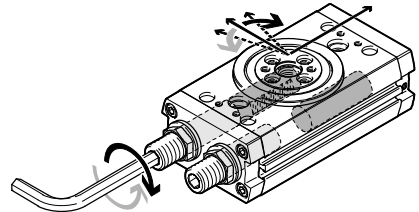

Fig. 9

Angle adjustment	Reaction	Setting range related to the basic factory setting (example DRRD-...-180)
Turn the shock absorber clockwise	Reduce the swivel angle	
Turn the shock absorber anti-clockwise	Increase the swivel angle	

Tab. 3

The following settings are possible:

Size		12	16	20	25	32	35	40	50	63
Elastic shock absorber on the DRRD-...-P										
Angle adjustment per rotation	[°]	9.6	8.7	9.0	6.6	8.2	8.2	5.4	–	
Max. shock absorber setting XPmax	[mm]	18.8	19	19.4	26.1	31.8	43.2	44.7	–	
Min. shock absorber setting XPmin	[mm]	6	6	6.7	9	11	13.5	13.5	–	
Hydraulic shock absorber on the DRRD-...-Y9/Y10/Y14										
Angle adjustment per rotation	[°]	9.6	8.7	9.0	6.6	8.2	8.2	5.4	3.8	2.9
Max. shock absorber setting XYmax	[mm]	29.9	38.5	43.3	64.9	80.7	99.9	101.4	130.4	126.9
Min. shock absorber setting XYmin		up to the minimum swivel angle (→ 12 Technical data)								

Tab. 4

6. Re-tighten the locking nut on the shock absorber by using the following tightening torque:

Size		12	16	20	25	32	35	40	50	63
☞ Internal hexagon socket	P [mm]	5	5	6	8	10	10	10	–	
	Y9/Y10/Y14 [mm]	2.5	3	4	5	5	6	6	8	8
☞ Lock nut	[mm]	10	13	15	19	27	32	32	36	46
Tightening torque	[Nm]	2	3	5	20	35	60	60	80	100

Tab. 5

7. Repeat the procedure to set the second end position.

6.2 Carrying out commissioning

1. Start a test run at low swivel speed.
2. When conducting the test run, check whether the DRRD settings need to be corrected.
These could be:
 - swivel angle of the payload (→ Tab. 3)
 - swivel speed of the payload.
3. Unscrew the one-way flow control valves (A) slowly again up to the desired swivel speed.
4. Interrupt the test run if the piston can be heard to strike hard.
Causes of metallic knocking may be:
 - mass moment of inertia of the payload too high
 - swivel speed of the payload too high
 - no compressed air cushion on the exhaust side
 - shock absorber unscrewed too far (maximum values → Tab. 4).
5. Make sure you remedy the above-mentioned causes.
6. End the test run when all of the necessary corrections have been undertaken.

7 Operation



Warning

Danger of injury from moving masses.

- Make sure that in the swivel angle of the DRRD
 - Nobody can reach in
 - No foreign objects can enter (e.g. by means of an individual protective guard).

For several uninterrupted swivel cycles:



Note

Operational reliability can be impaired by an excessive temperature rise.

- Make sure that the following maximum swivel frequency is not exceeded.

Size			12	16	20	25	32	35	40	50	63
Maximum swivel frequency ^{1) 2)}	P	[Hz]	2.4	2.9	2.0	2.0	2.1	1.4	1.5	–	
	Y9	[Hz]	1.3	1.25	1.4	0.9	0.5	0.45	0.5	0.5	0.6
	Y10	[Hz]	–			0.6	–	0.3	0.3	0.3	0.28
	Y14	[Hz]	–	2.9	2.1	1.7	1.0	0.9	1.1	–	

1) Longer reset times are to be expected at temperatures below 0 °C for all Y9/Y10/Y14 versions; it is therefore possible that the maximum swivel frequency can no longer be reached under certain circumstances

2) The housing temperature of the shock absorber housing should not exceed 60 °C

Tab. 6

8 Maintenance and care

To check the function of the shock absorbers:

- Proceed as follows:

DRRD-...	P	Y9/Y10/Y12/Y14
Test interval	2 million switching cycles	2 million switching cycles (DRRD-12 ... 40) 1 million switching cycles (DRRD-50/63)
Procedure	<ol style="list-style-type: none"> 1. Check the function of the shock absorbers. In case of audible bottoming out or rebounding: 2. Replace the cushioning components and seals (lubricate the cushioning components before installation with, for example, LUB-KC1). 	<ol style="list-style-type: none"> 1. Check the function of the shock absorbers for bottoming out and rebounding. 2. Unscrew the shock absorber and check for oil leaks. In case of audible bottoming out, rebounding or visible oil loss: 3. Replace the shock absorber and seals (→ 9 Disassembly and repair).
Replacement interval	If there is evidence of wear (bottoming out)	If there is evidence of bottoming out, leaking oil or every 10 million switching cycles (DRRD-12 ... 40) Every 5 million switching cycles (DRRD-50) Every 2 million switching cycles (DRRD-63)

Tab. 7

If the piston can be heard to strike hard in the end position:

- Replace the following components if they are worn (→ 9 Disassembly and repair):
 - the internal cushioning components of the DRRD-...-P
 - both shock absorbers of the DRRD-...-Y9/Y10/Y14.
- If the DRRD is contaminated, clean it with a soft cloth.
Permissible cleaning agents include:
 - warm soap suds up to +60 °C
 - petroleum ether
 - all non-abrasive cleaning agents.

9 Disassembly and repair

For eccentric masses on the lever arm:



Warning

Danger of injury from masses dropping suddenly.

- Make sure the payload has reached a stable position before venting (e.g. the lowest point).



Note

- Make sure that the semi-rotary drive is vented for disassembly.

- Recommendation: Send the product to our repair service. This way the required fine tuning and tests will be taken into special consideration.
- Information about spare parts and aids can be found at: www.festo.com/spareparts

For replacement of the integrated cushioning components/shock absorbers (→ 10 Accessories):

- Proceed as follows:
 1. Vent the DRRD.
 2. Measure the position of the shock absorber (dimension XP or XY) and loosen the lock nut on the shock absorber [8].
 3. Unscrew the shock absorber and:
 - Lubricate the new cushioning component (e.g. with LUB-KC1) and mount it (for DRRD-...-P). Use new sealing discs (→ (B) in Fig. 10), if required
 - Replace shock absorber (for DRRD-...-Y9/Y10/Y14). Use new sealing discs (→ (C) in Fig. 10), if required.
 4. Screw in shock absorbers up to dimension XP or XY (→ point 2).
 5. Check the angle adjustment and correct, if necessary.
 6. Tighten the lock nut on the shock absorber [8] (tightening torque → Tab. 5).

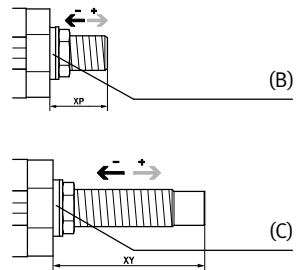

Fig. 10

10 Accessories



Note

- Please select the corresponding accessories from our catalogue (→ www.festo.com/catalogue).

11 Trouble-shooting

Malfunction	Possible cause	Remedy
Uneven movement of the effective load	Flow control valves inserted incorrectly	Check the flow control function (supply or exhaust air flow control)
	Asymmetric angle setting	Symmetric setting preferred
	DRRD defective	Return to Festo
Hard metal impact at the end position Drive shaft does not remain in the end position (bouncing)	Residual energy too high	Select a lower swivel speed
		Use external shock absorbers (→ 10 Accessories)
		Move only against residual air cushion on the exhaust side
		Select a lighter mass
	Semi-rotary drive moves against an unpressurized chamber	Pressurize semi-rotary drive on both sides
	Shock absorber unscrewed too far	Observe the maximum permissible unscrewing length
Shock absorber/cushioning component defective/worn	Replace shock absorber/cushioning component (→ 9 Disassembly and repair)	

Tab. 8

12 Technical data

Size	12	16	20	25	32	35	40	50	63	
Design	Semi-rotary drive with twin pistons									
Cushioning at both ends	P	Elastic cushioning, with metal end position							–	
	Y9	Hydraulic shock absorber								
	Y10	–			Hydraulic shock absorber (hard) ⁴⁾					
	Y14	–	Hydraulic shock absorber (soft)					–		
Pneumatic port	M5	M5	M5	M5	G1/8	G1/8	G1/8	G1/4	G3/8	
Operating medium	Compressed air to ISO 8573-1:2010 [7:4:4]									
Note on the operating medium	Lubricated operation possible (in which case lubricated operation will always be required)									
Operating pressure	P [bar]	3 ... 8							–	
	Y9/Y10/Y14 [bar]	2 ... 10								
Mounting position	Any									
Swivel angle [°]	180									
Setting range on both sides	P [°]	Infinitely adjustable between –100 ... +10							–	
	Y9/Y10/Y14 [°]	Infinitely adjustable between –100 ... +10 ¹⁾								
Cushioning angle (△ minimum swivel angle)	P [°]	32	36	45	33	33	36	23	–	
	Y9/Y10/Y14 [°]	48	43	72	79	82	85	56	61	48
Repetition accuracy [°]	≤ 0.03							< 0.05		≤ 0.03
Ambient temperature [°C]	–10 ... +60									
Torque at 6 bar (theor.) [Nm]	0.8	1.59	2.41	5.15	10.1	15.8	24.1	53.0	112	
Max. axial load (static) [kN]	1.4 ³⁾	1.5	2.4	2.4	3.75	6.1	6.1	9.0	11.0	
Max. permissible axial and radial force on drive shaft	Dependent on the distance of the force application point (→ www.festo.com/catalogue)									
Max. permissible mass moment of inertia	Depending on the product type (→ www.festo.com/catalogue)									
End-position adjustment	By turning the cushioning components									
Note on materials	Contains paint-wetting impairment substances (PWIS)									
Materials										
Housing, cover	Anodised aluminum									
Shaft, screws, plug and retaining plate for DRRD-12	Steel									
Seals	TPE-U (PU), NBR									
Product weight ²⁾	P [kg]	0.38	0.64	0.84	1.35	2.82	4.51	6.07	–	
	Y9/Y10/Y14 [kg]	0.39	0.65	0.88	1.36	2.98	4.78	6.42	11.3	19.1

1) Reduction possible on one side > 100°; observe the cushioning angle as the minimum swivel angle

2) Basic design with internal cushioning, without accessories

3) Pressure load (tensile load: 0.33 kN)

4) With DRRD-32, Y10 is not available

Tab. 9

Copyright:
Festo AG & Co. KG
Ruiter Straße 82
73734 Esslingen
Germany

Phone:
+49 711 347-0

Fax:
+49 711 347-2144

Reproduction, distribution or sale of this document or communication of its contents to others without express authorization is prohibited. Offenders will be liable for damages. All rights reserved in the event that a patent, utility model or design patent is registered.

E-mail:
service_international@festo.com

Internet:
www.festo.com