

Safety Sub-functions
SS1-t Category 1, up to PL c
STO Category 1, up to PL c
PUS Category 1, up to PL c

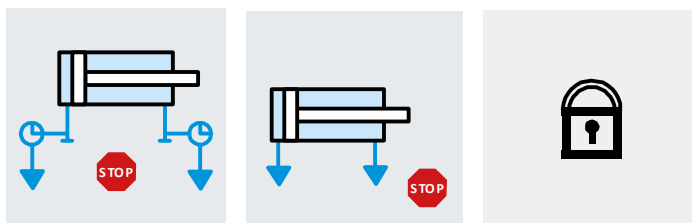

Application Note
SS1-t, STO, PUS,
Category 1, up to PL
c

Title Application Note SS1-t, STO, PUS, Category 1, up to PL c
Version 1.0
Document number (TSHQ) 100226
Original German
Author Festo
Last date of saving 26.04.2019

Legal Notice

In the following, the “Festo AG & Co.KG” is designated as “Festo”.

This Example circuit is not binding. This example circuit outlines a possible solution for a sample application and makes no claim of completeness, especially with regard to configuration and equipment, as well as any eventualities for your actual application. The Example circuit is not a customised solution, it merely offers assistance with typical task assignments.

The values stated in the Example circuit are partly assumptions and assessments which do not replace a detailed examination based on EN ISO 13849 part 1 and 2.

The actual characteristic values that can be obtained (especially PL, PFH_D, category, DC, MTT_D, CCF) depend on the components used, as well as their conditions of use in the actual application.

The example circuit does not relieve you of the obligation to carry out a risk assessment and a validation of the specific application and to ensure the adherence to all specifications, especially the EC Machinery Directive 2006/42/EG. As the user, you are responsible for your specific application and for the correct operation of the described products.

Festo does not accept any liability for damages arising from the use of any incorrect or incomplete information contained in this documentation or any information missing therefrom. This equally applies to defects resulting from improper handling of devices and modules. In addition, all liability, with the exception of intent or gross negligence on the part of Festo, for damages arising due to non-adherence of the specifications of the EC Machinery Directive 2006/42/EG is also rejected.

The information in this document is in no way intended as a substitute for the operating instructions of the respective manufacturers or the design and testing of the application by the user. The operating instructions for products from Festo can be found at www.festo.com. Users of this document must themselves verify that all the functions described herein also work correctly in the application. Even after examining this document and using the specifications contained herein, users are nevertheless solely responsible for their own application.

Otherwise, all stipulations concerning liability included in the terms and conditions of delivery, payment and use of software from Festo, which can be found at www.festo.com and can be supplied on request, apply.

This document is only suitable for persons with sufficient expertise for machine safety based on EN ISO 12100 and EN ISO 13849. In addition, the following qualifications are required in the project team:

- Specialist in pneumatics
- Specialist in electrical engineering
- Specialist for the programming of control systems and safety switching devices

Copyright Notice

This documentation is the intellectual property of Festo, which also holds the exclusive copyright. Any modification of the content, duplication or reprinting of this documentation, as well as distribution to third parties, is only permissible with the express consent of Festo.

Festo reserves the right to make modifications to this document in whole or in part. All brand and product names are trademarks or registered trademarks of their respective owners.

© (Festo AG & Co.KG, D - 73734 Esslingen, 2018)

Internet: www.festo.com

E-Mail: service_international@festo.com

Table of Content

1	Example Circuits	4
1.1	SS1-t with 5/3 and 3/2 Directional Control Valves, Category 1, up to PL c.....	5
1.1.1	Circuit Diagram	5
1.1.2	Components.....	5
1.1.3	Description.....	6
1.1.4	Safety Considerations	7
1.2	SS1-t with 3/2 Directional Control Valves, Category 1, up to PL c	8
1.2.1	Circuit Diagram	8
1.2.2	Components.....	8
1.2.3	Description.....	9
1.2.4	Safety Considerations	10
1.3	SS1-t with 2/2 Directional Control Valves, Category 1, up to PL c	11
1.3.1	Circuit Diagram	11
1.3.2	Components.....	11
1.3.3	Description.....	12
1.3.4	Safety Considerations	13
2	Literature	13

1 Example Circuits

- The circuits specified in this document are principle circuits which cannot be complete due to their clarity and scope.
- The abbreviations used for the safety sub-functions refer to the definitions in VDMA 24584 [1] for pneumatics:
 - SS1-t: Safe Stop 1, time controlled
 - STO: Safe Torque Off
 - PUS: Prevention of unexpected start-up
- Category and PL according EN ISO 13849-1 [2]
- The circuits and the procedure described are recommendations which do not exclude other possibilities.
- Due to the wide variety of possible valves, no valve type and part numbers can be given in this document. When selecting valves, make sure that the selected valves have the following characteristics:
 - Type of actuation: electrical
 - Type of reset: mechanical spring
 - Sealing principle: soft
 - Type of piloting: piloted
 - Pilot air supply: internal or external
 - Duty cycle: 100%.
 - Well-tried components according to EN ISO 13849-1 and the relevant basic and well-tried safety principles have been observed.
 - B10 value required for the calculation of the $MTTF_D$ value must be available.

Important note

- In addition, further design features and requirements may exist, which must be determined depending on the application.

1.1 SS1-t with 5/3 and 3/2 Directional Control Valves, Category 1, up to PL c

SS1-t, STO and PUS according VDMA 24584 [1] and category 1, up to PL c according EN ISO 13849-1 [2].

1.1.1 Circuit Diagram

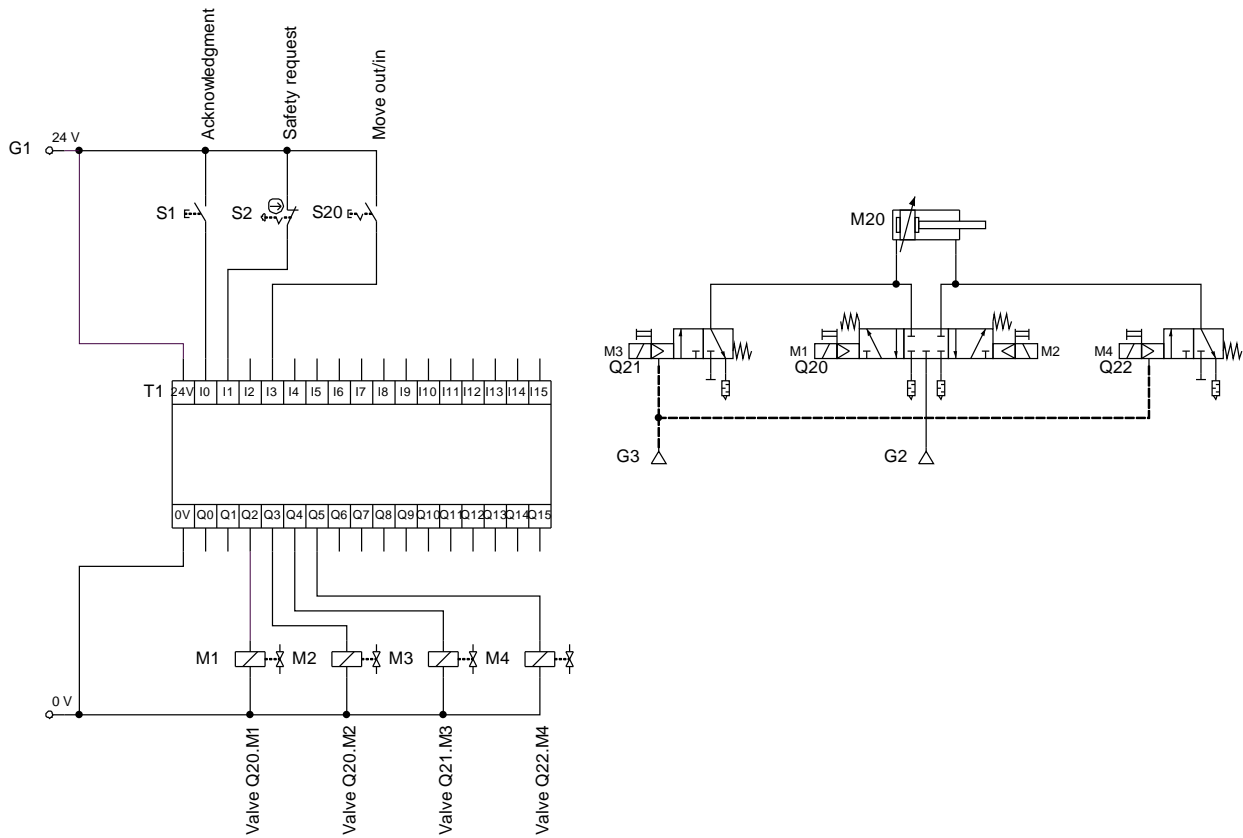

1.1.2 Components

Component	Type	Description / Part Number / Remarks	Qty.	Mssr.
M20		Pneumatic drive	1	Festo
Q20		5/3 directional control valve, monostable	1	Festo
Q21, Q22		3/2 directional control valve, monostable	2	Festo
		Blanking plug, suitable for the connection of the selected valve	2	Festo
		Silencer, if necessary	4	Festo
S1		Acknowledge push button	1	
S2		Safety commanding device, e.g. emergency stop switch	1	
S20		Switch functional control	1	
T1		Safety switching device	1	

1.1.3 Description

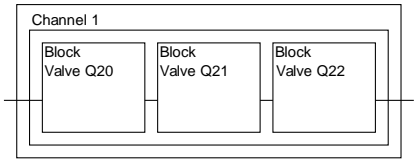
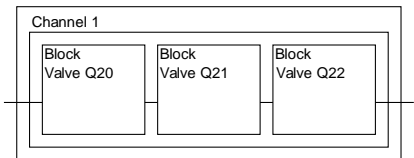
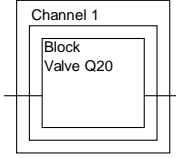
Application	Double acting pneumatic drive, horizontal
Triggering event	Safety request, e.g. by emergency stop switch, safety gate
Reaction (Safety Sub-function)	<p>Safe Stop 1, time controlled (SS1-t), category 1, PL c</p> <p>Subsystem valves</p>  <p>Safe torque off (STO), category 1, PL c</p> <p>Subsystem valves</p>  <p>Prevention of unexpected start-up (PUS), category 1, PL c</p> <p>Subsystem valves</p> 
Safe state	The pneumatic drive is stopped time-controlled, exhausted and free of energy. It is presumed that the exhausted state of the pneumatic drive is the safe state.
Function	<p>The safety requirement (S1):</p> <ol style="list-style-type: none"> 1. Interrupts the input circuit of the safety switching device (T1). 2. The safe output of the safety switching device (T1) for the valve (Q20) is switched off so that the valve is no longer controlled and switches to the normal position. In the normal position, the pneumatic flow paths are closed by the valve. This stops the pneumatic drive (M20). 3. With a time delay, the safe outputs of the safety switching device (T1) for the valves (Q22, Q23) are switched off so that they are no longer controlled and switch to the normal position. In the normal position of the valves, both chambers of the pneumatic drive (M20) are exhausted. Depending on the pressure conditions in the chambers of the pneumatic drive (M20), this exhaust can cause a movement.
Manual reset function	<ol style="list-style-type: none"> 1. After resetting the safety request (S2), e.g. by mechanically unlocking the emergency stop switch or closing the safety guard, the start or restart can be made possible by pressing the acknowledge push button (S1). 2. When starting or restarting, the safe outputs of the safety switching device (T1) for the valves (Q21, Q22) are first switched on so that they switch to their switching position and close the pneumatic flow paths. 3. The safe outputs of the safety switching device (T1) for the valve (Q20) are enabled with a time delay so that the valve (Q20) can switch to the desired switching position and enable normal operation.

1.1.4 Safety Considerations

Input	Safety considerations must be carried out in accordance with the selected safety commanding device (S2).
Logic	Safety considerations must be carried out in accordance with the selected safety switching device (T1).
Output	The valves (Q20, Q21, Q22) are well-trying components according to EN ISO 13849-1 and the relevant basic and well-trying safety principles have been observed. B10 value required for the calculation of the $MTTF_D$ must be available.

1.2 SS1-t with 3/2 Directional Control Valves, Category 1, up to PL c

SS1-t, STO and PUS according VDMA 24584 [1] and category 1, up to PL c according EN ISO 13849-1 [2].

1.2.1 Circuit Diagram

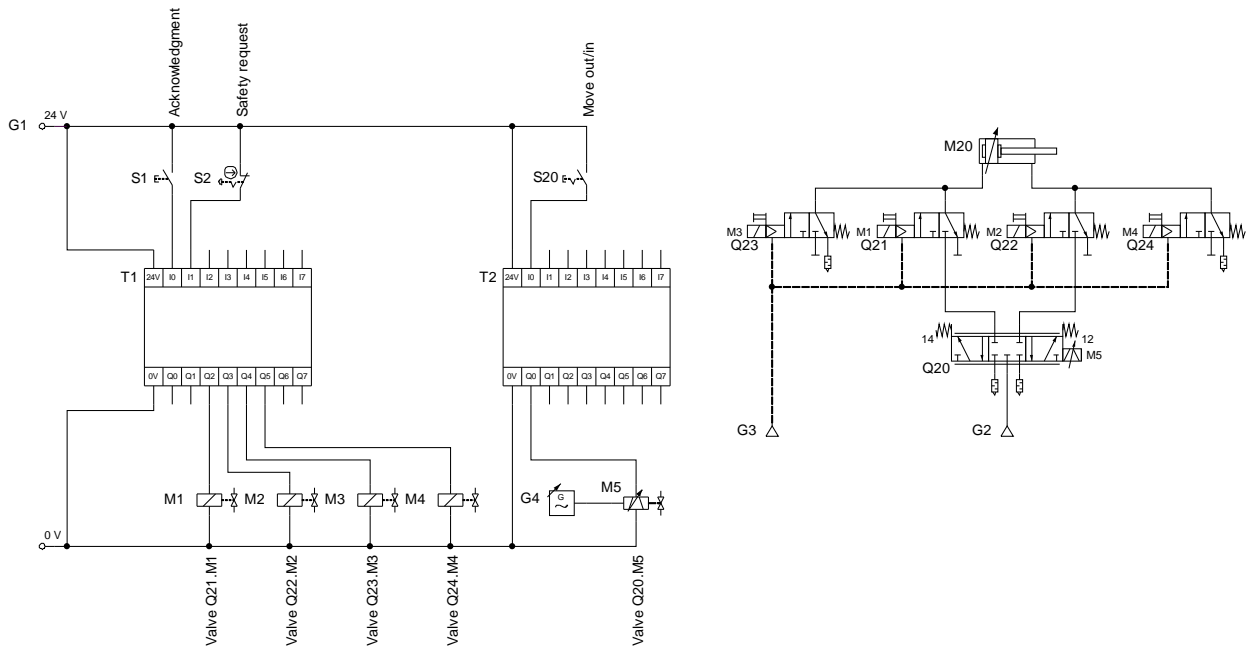

1.2.2 Components

Component	Type	Description / Part Number / Remarks	Qty.	Mssr.
M20		Pneumatic drive	1	Festo
Q20, G4		Any valve for controlling the direction of movement, here a proportional valve	1	Festo
Q21, Q22, Q23, Q24		3/2 directional control valve, monostable	4	Festo
		Blanking plug, suitable for the connection of the selected valve	2	Festo
		Silencer, if necessary	2	Festo
S1		Acknowledge push button	1	
S2		Safety commanding device, e.g. emergency stop switch	1	
S20		Switch functional control	1	
T1		Safety switching device	1	
T2		Functional PLC	1	

1.2.3 Description

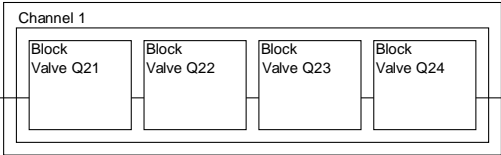
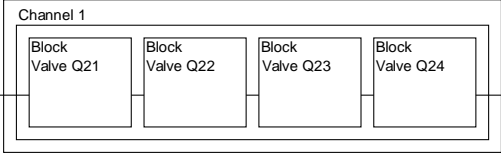
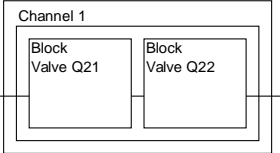
Application	Double acting pneumatic drive, horizontal
Triggering event	Safety request, e.g. by emergency stop switch, safety gate
Reaction (Safety Sub-function)	<p>Safe Stop 1, time controlled (SS1-t), category 1, PL c</p> <p>Subsystem valves</p>  <p>Safe torque off (STO), category 1, PL c</p> <p>Subsystem valves</p>  <p>Prevention of unexpected start-up (PUS), category 1, PL c</p> <p>Subsystem valves</p> 
Safe state	The pneumatic drive is stopped time-controlled, exhausted and free of energy. It is presumed that the exhausted state of the pneumatic drive is the safe state.
Function	<p>The safety requirement (S1):</p> <ol style="list-style-type: none"> 1. Interrupts the input circuit of the safety switching device (T1). 2. First the valve (Q20) should be brought into the closed normal position. This closes ports 2 and 4 of the valve (Q20). 3. The safe outputs of the safety switching device (T1) for the valves (Q21, Q22) are switched off so that the valves is no longer controlled and switch to the normal position. In the normal position, the pneumatic flow paths are closed by the valves. This stops the pneumatic drive (M20). 4. With a time delay, the safe outputs of the safety switching device (T1) for the valves (Q23, Q24) are switched off so that they are no longer controlled and switch to the normal position. In the normal position of the valves, both chambers of the pneumatic drive (M20) are exhausted. Depending on the pressure conditions in the chambers of the pneumatic drive (M20), this exhaust can cause a movement. <p>Notes</p> <ul style="list-style-type: none"> • The valve (Q20) is not involved in these safety functions and cannot fail dangerously with respect to these safety functions.
Manual reset function	<ol style="list-style-type: none"> 1. After resetting the safety request (S2), e.g. by mechanically unlocking the emergency stop switch or closing the safety guard, the start or restart can be made possible by pressing the acknowledge push button (S1). 2. When starting or restarting, the safe outputs of the safety switching device (T1) for the valves (Q23, Q24) are first switched on so that they switch to their switching position and close the pneumatic flow paths. 3. The safe outputs of the safety switching device (T1) for the valves (Q21, Q22) are switched on with a time delay so that the valves (Q21, Q22) can switch to the desired switching position and enable normal operation. <p>Notes</p> <ul style="list-style-type: none"> • In the case of proportional valves with external sensors, the control loop may cause an output to be pressurised with operating pressure or exhausted. This can lead to a movement with a high force and speed with the manual reset function. Whether this can lead to a hazard must be assessed depending on the application.

1.2.4 Safety Considerations

Input	Safety considerations must be carried out in accordance with the selected safety commanding device (S2).
Logic	Safety considerations must be carried out in accordance with the selected safety switching device (T1).
Output	The valves (Q21, Q22, Q23, Q24) are well-tried components according to EN ISO 13849-1 and the relevant basic and well-tried safety principles have been observed. B10 value required for the calculation of the $MTTF_D$ must be available.

1.3 SS1-t with 2/2 Directional Control Valves, Category 1, up to PL c

SS1-t, STO and PUS according VDMA 24584 [1] and category 1, up to PL c according EN ISO 13849-1 [2].

1.3.1 Circuit Diagram

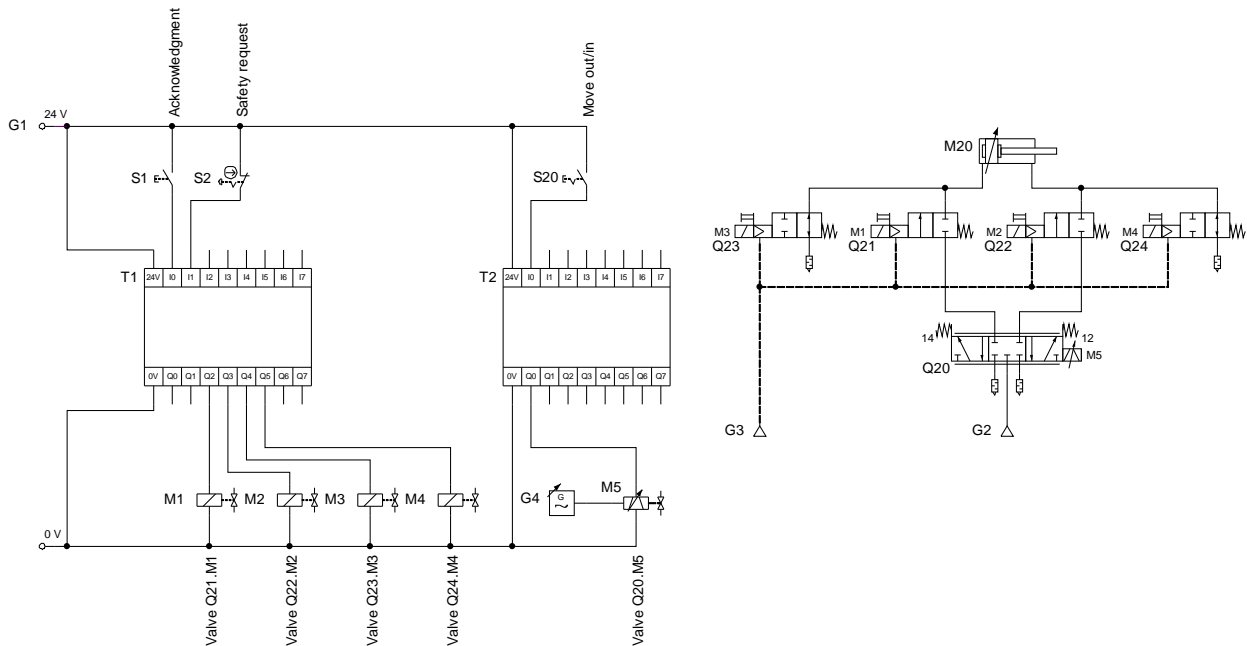

1.3.2 Components

Component	Type	Description / Part Number / Remarks	Qty.	Mssr.
M20		Pneumatic drive	1	Festo
Q20, G4		Any valve for controlling the direction of movement, here a proportional valve	1	Festo
Q21, Q22, Q23, Q24		2/2 directional control valve, monostable	4	Festo
		Silencer, if necessary	2	Festo
S1		Acknowledge push button	1	
S2		Safety commanding device, e.g. emergency stop switch	1	
S20		Switch functional control	1	
T1		Safety switching device	1	
T2		Functional PLC	1	

1.3.3 Description

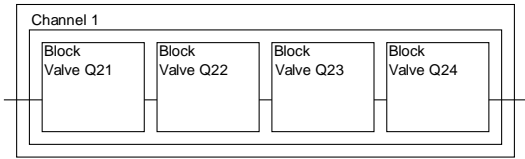
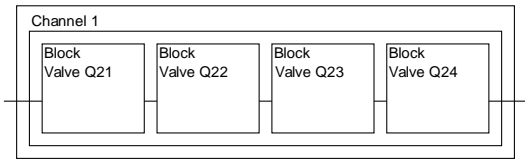
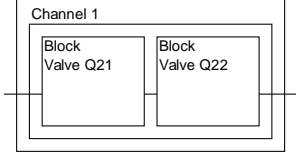
Application	Double acting pneumatic drive, horizontal
Triggering event	Safety request, e.g. by emergency stop switch, safety gate
Reaction (Safety Sub-function)	<p>Safe Stop 1, time controlled (SS1-t), category 1, PL c</p> <p>Subsystem valves</p>  <p>Safe torque off (STO), category 1, PL c</p> <p>Subsystem valves</p>  <p>Prevention of unexpected start-up (PUS), category 1, PL c</p> <p>Subsystem valves</p> 
Safe state	The pneumatic drive is stopped time-controlled, exhausted and free of energy. It is presumed that the exhausted state of the pneumatic drive is the safe state.
Function	<p>The safety requirement (S1):</p> <ol style="list-style-type: none"> 1. Interrupts the input circuit of the safety switching device (T1). 2. First the valve (Q20) should be brought into the closed normal position. This closes ports 2 and 4 of the valve (Q20). 3. The safe outputs of the safety switching device (T1) for the valves (Q21, Q22) are switched off so that the valves is no longer controlled and switch to the normal position. In the normal position, the pneumatic flow paths are closed by the valves. This stops the pneumatic drive (M20). 4. With a time delay, the safe outputs of the safety switching device (T1) for the valves (Q23, Q24) are switched off so that they are no longer controlled and switch to the normal position. In the normal position of the valves, both chambers of the pneumatic drive (M20) are exhausted. Depending on the pressure conditions in the chambers of the pneumatic drive (M20), this exhaust can cause a movement. <p>Notes</p> <ul style="list-style-type: none"> • The valve (Q20) is not involved in these safety functions and cannot fail dangerously with respect to these safety functions.
Manual reset function	<ol style="list-style-type: none"> 1. After resetting the safety request (S2), e.g. by mechanically unlocking the emergency stop switch or closing the safety guard, the start or restart can be made possible by pressing the acknowledge push button (S1). 2. When starting or restarting, the safe outputs of the safety switching device (T1) for the valves (Q23, Q24) are first switched on so that they switch to their switching position and close the pneumatic flow paths. 3. The safe outputs of the safety switching device (T1) for the valves (Q21, Q22) are switched on with a time delay so that the valves (Q21, Q22) can switch to the desired switching position and enable normal operation. <p>Notes</p> <ul style="list-style-type: none"> • In the case of proportional valves with external sensors, the control loop may cause an output to be pressurised with operating pressure or exhausted. This can lead to a movement with a high force and speed with the manual reset function. Whether this can lead to a hazard must be assessed depending on the application.

1.3.4 Safety Considerations

Input	Safety considerations must be carried out in accordance with the selected safety commanding device (S2).
Logic	Safety considerations must be carried out in accordance with the selected safety switching device (T1).
Output	The valves (Q21, Q22, Q23, Q24) are well-tried components according to EN ISO 13849-1 and the relevant basic and well-tried safety principles have been observed. B10 value required for the calculation of the $MTTF_D$ must be available.

2 Literature

- [1] VDMA 24584:2016-08 - Safety functions of regulated and unregulated (fluid) mechanical systems (German edition)
- [2] DIN EN ISO 13849-1:2016-06 - Safety of machinery - Safety-related parts of control systems - Part 1: General principles for design (ISO 13849-1:2015); German version EN ISO 13849-1:2015