

Servo press kit YJKP for electrical press-fitting applications

FESTO

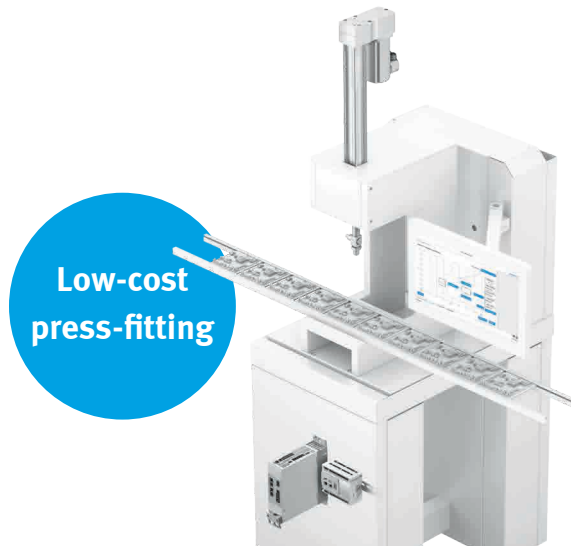

Correctly sized!

Highlights

- Suitably designed
- Less expensive than conventional press-fitting systems
- Software and hardware from a single source
- Pre-installed modular software
- Pre-assembled kit
- Press forces up to 17 kN (variants up to 100 kN on request)
- Easy to integrate into your own system concept
- Compatible with Industry 4.0

The modular servo press kit YJKP gives you just the software functions you need for your application. You get an extremely precise press-fitting system with a high level of repetition accuracy and an excellent price/performance ratio. Simple, cost-effective and quick to install.

Pre-assembled system kit

The YJKP consists of modular operating software and harmonised standard Festo components so there is always a right size for every application. With electric spindle drive, motor, motor controller, force sensor and control system, you have everything you need for electrical press-fitting tasks up to 17 kN (variants up to 100 kN on request). All you have to do is integrate it into your application.

Pre-installed software

The pre-installed operating software is ready to use straight away and you don't need to be a programming expert to parameterise it, it's that easy and intuitive. The modular software featuring application-specific functions can be used on a PC, iPad or other human-machine interfaces and is compatible with all types of platforms. The press controller with OPC-UA interface makes the system ready for Industry 4.0.

Flexible applications

You can exchange control and process data with a higher-order controller over an Ethernet interface as soon as the press controller is integrated into the local network.

Areas of application

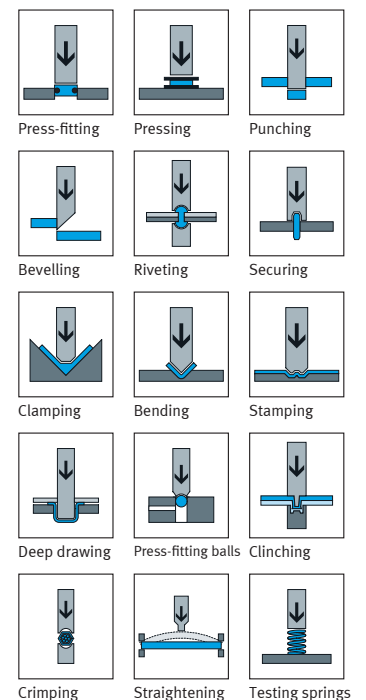

Coordinated system solution...

Individual and flexible design: the pre-assembled system kit

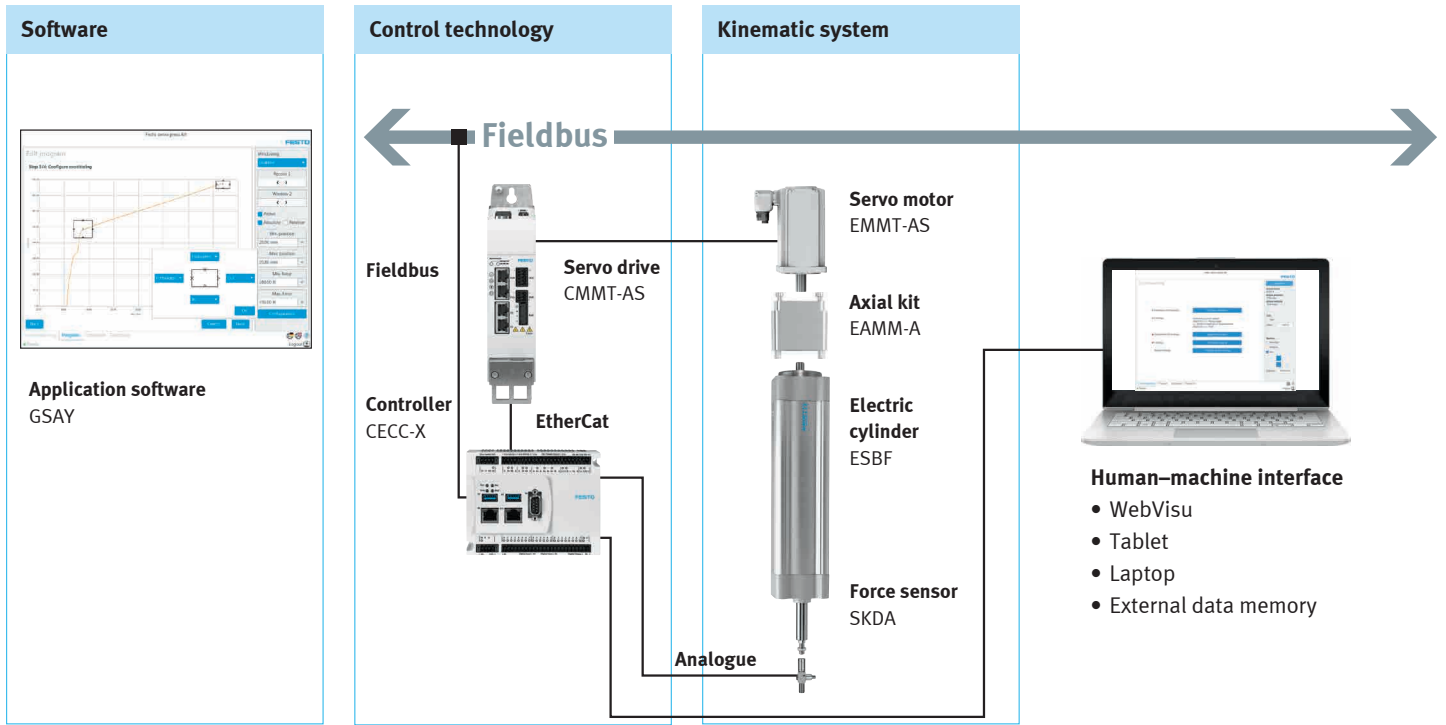

Added flexibility with the modular system

Individually adapt your servo press kit to your application requirements!

- Force ranges: 0.8 ... 17 kN (up to 100 kN on request)
- Stroke lengths: 100 ... 400 mm
- Choice of axial or parallel motor attachment
- Motor with or without holding brake
- Single turn or multi-turn encoder
- Suitable and sufficient cable length prevents expensive oversizing

Reduces the assembly required: the pre-assembled cylinder-kit-motor combination

The electric cylinder with spindle drive, the mounting kit and the servo motor are assembled in one application-specific module. This reduces the number of individual components you need to handle. You can integrate this module directly into the system thanks to defined mechanical and electrical interfaces. After completion, a full performance test is carried out. The entire assembly process is therefore taken care of for you.

Your documentation process also becomes much easier: you can conveniently integrate the configuration-specific CAD data from the assembly drawing into your documentation.



Axial motor attachment

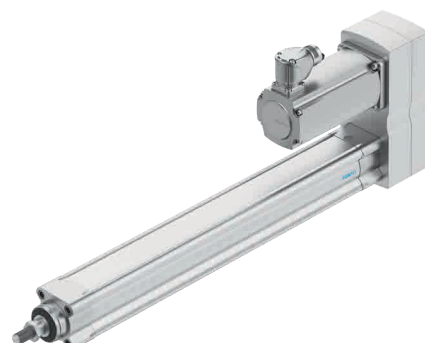

Parallel motor attachment

...and modular operating software from a single source

Modular software for configuration, operation and visualisation

Ready-to-use operating software

The operating software is already installed on the press controller – and therefore ready to use as soon as system integration is complete. No programming skills are needed. Thanks to the integrated sequencer, press-fitting operations are quick to configure and easy to implement.

Monitoring the process is simple. Everything is displayed clearly and logically:

- Configurator for the joining process: feed/joining path, possible wait times, threading functionality, etc.
- Recording process data for quality assurance
- Recorded force/displacement graph exported as *.csv file
- Analysis functions for the force/displacement graph
- Definition of windows
- Envelopes
- Through points
- Software customisable

Platform-independent basic software GSAY GSAY-A4-F0-Z4-L-Y0

The modular operating software can be displayed on a PC, tablet or other human-machine interfaces and is compatible with all types of platforms.

Latest version available free of charge in the App World

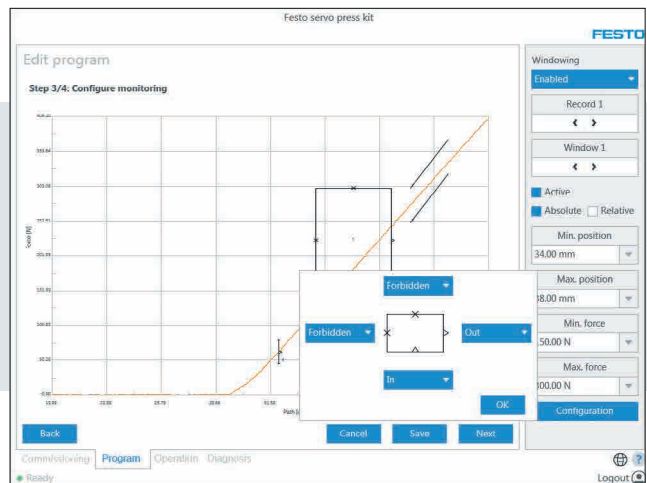

Advanced software package GSAY-A4-F0-Z4-L-Y1

For even more individual adaptation to the application and for specific tasks. With selected features at an attractive price, e.g.

- Force control
- OPC-UA connection
- Advanced sequencer

Available to purchase via the App World

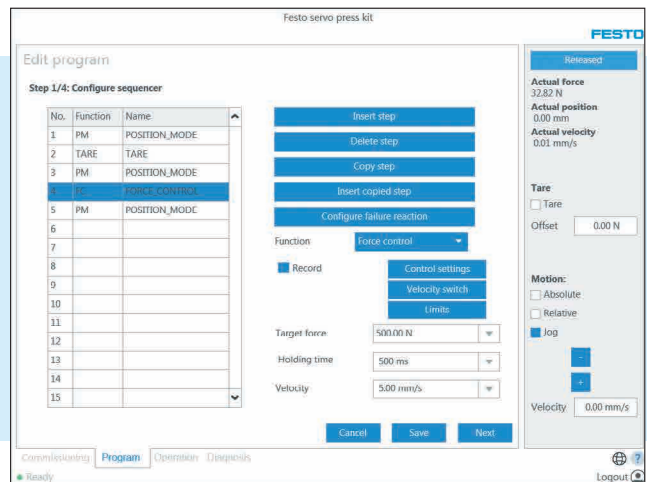

www.festo.com/AppWorld

Optimally designed: the matching, configuration-specific accessories

Our accessories make your automation even more productive because they are optimally designed for the servo press kit YJKP. They are particularly reliable, perfectly matched and make routine daily work easier.

Guide unit EAGF:

For protecting electric cylinders against torsion when these are subjected to high torque loads and for high guide accuracy during workpiece handling.

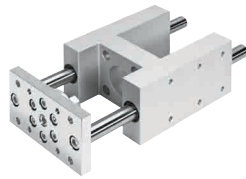

Flange mounting EAHH:

For mounting the electric cylinder via the profile. The position is freely selectable along the cylinder length.

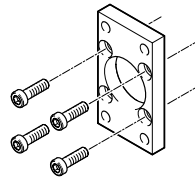

Profile mounting EAHF:

Always securely fastened.

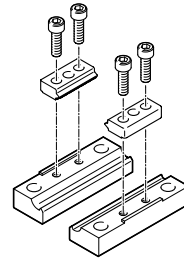

Our support guarantees you productivity advantages. With our configuration-specific CAD data and EPLAN macros, you achieve your goals quickly and easily.

Configuration-specific CAD files:

For quick, easy and correct documentation.

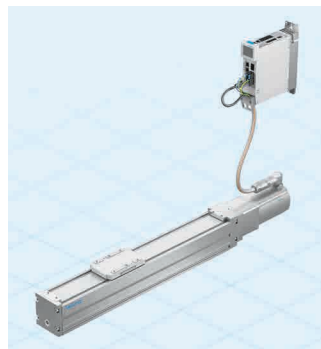

Configuration-specific EPLAN macros:

For maximum process reliability.



Technical data

Storage temperature [°C]	-10 ... +60
Operating temperature [°C]	0 ... +40
Stroke length [mm]	100, 200, 300, 400
Force ranges [kN]	0.1 – 0.8, 1.5, 4, 7, 12, 17 ¹⁾
Max. feed speed [mm/s]	250
Repetition accuracy [mm]	≤ ± 0.01
Interface	EtherNet, 24 V I/O
Bus systems	Modbus-TCP, EtherNet/IP, EtherNet TCP/IP, Profinet, OPC-UA
Configuration via visualisation system	Force/displacement diagrams
	Default for good/bad parts
	Visualisation

FS accuracy of force measurement ²⁾ [%]	± 0.25
Measuring speed for force sensor	1,000 measurements/s
Evaluation methods	Window technique
	Threshold
	Envelope
Visualisation	At the customer's premises via a web browser

¹⁾ Other variants and output stages up to 100 kN on request.

²⁾ Related to the pressing force of the complete system.
Example for YJKP-0.8: 0.25% x 800 N