

Electric cylinder EPCC

FESTO



Easy positioning!

Highlights

- Dynamic due to low internal friction
- Fast positioning times
- Low-cost: best price-performance ratio
- Flexible: wide range of mounting options for the motor
- Unique: "one-size-down" assembly system for excellent use of space

Cost-effective, yet powerful and very flexible: the EPCC with ball screw drive enables precise and rapid positioning in simple positioning tasks. And its compact dimensions are ideal when you need to make optimum use of installation space: in assembly systems, test and inspection systems or desktop applications, in small parts handling or the electronics industry.

Compact and precise

The compact ball screw drive with integrated coupling and double bearing ensures quiet spindle operation and precise positioning, while the life-time lubrication ensures a long service life. The 4 sizes with non-rotating, plain-bearing guided piston rod and a stroke of up to 500 mm make it very suitable for a wide range of applications, as does the free selection of axial or parallel motor position, which you can convert at any time.

Flexible position sensing

A position magnet for position sensing is integrated in the spindle nut, and the proximity sensor can be freely positioned on 3 sides of the cylinder.

"One-size-down" assembly system

The universal profile mounting allows space-saving mounting of the electric cylinder on the linear axis ELGC – without the need for additional adapters. Especially handling systems benefit from the weight-optimised design of the EPCC.

Electric cylinder EPCC

The EPCC at a glance



Pressure compensation port

- Standard: sintered plate screwed into the port
- Optional: pressure compensation air added later so that ambient particles or moisture are not sucked into the electric cylinder and no particles are emitted from the drive into the ambient air.

Very flexible motor mounting

Free choice of motor positions (turned 4 x 90°) and mounting kits (axial or parallel); can also be changed at a later date.

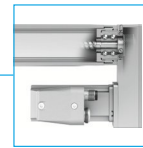
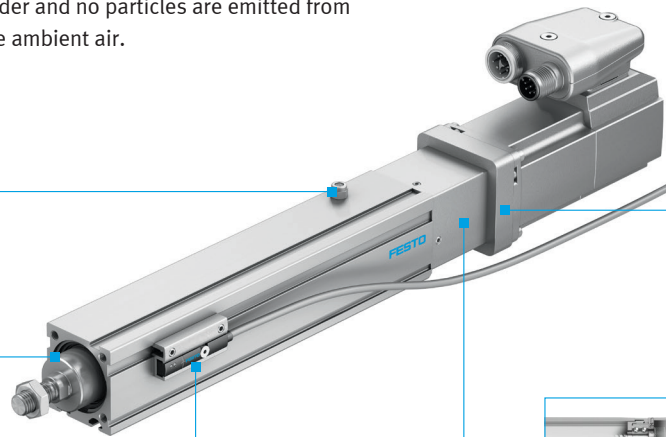
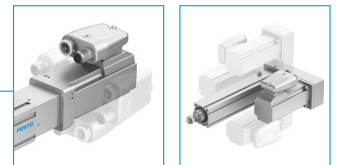

Double bearing and coupling

Double ball bearing to absorb drive forces and torques:

- Space-saving in the cylinder
- No additional bearing of pinions required in the parallel kit
- Extremely compact coupling as part of the cylinder
- Easy to replace during servicing

Smooth-running ball screw drive

- High grade ball screw drive with low internal friction
- The minimal basic load torque allows use of a smaller motor
- This reduces both size and weight as well as the power consumption

Cost-effective position sensing

- Standard: integrated position magnet
- Sensing using proximity sensor SMT-8M
- Sensor bracket for flexible, secure and rapid mounting on the profile
- Can be extended or repositioned at any time

Important technical data at a glance

Size	25	32	45	60
Drive and guide	Ball screw drive/plain-bearing guide			
Stroke length [mm]	25–200	25–200	25–300	25–500
Max. feed force [N]	75	150	450	1000
Max. speed (low/high) [mm/s]	133/400	188/500	180/600	250/600
Spindle pitch (low/high) ¹ [mm]	2/6	3/8	3/10	5/12
Max. rotary speed [rpm]	4000	3750	3600	3000
Max. acceleration [m/s ²]	15			
Repetition accuracy [mm]	± 0.02			