

Terminal CPX

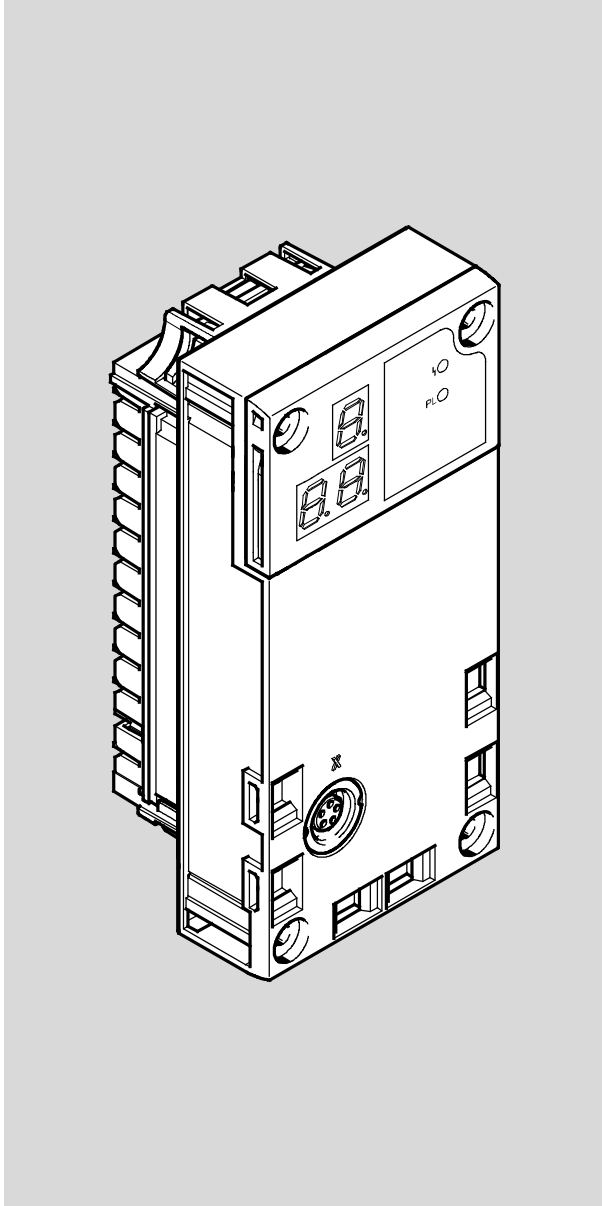

FESTO

Manual

FHPP interface

Type
CPX-CM-HPP

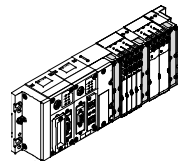

Manual

568 684
en 1409a
[8040658]

Contents and general instructions

Original de

Edition en 1409a

Designation P.BE-CPX-CM-HPP-EN

Order no. 568 684

© (Festo AG & Co. KG, D-73726 Esslingen, Germany, 2009)

Internet: <http://www.festo.com>

E-Mail: service_international@festo.com

The reproduction, distribution and utilization of this document as well as the communication of its contents to others without express authorization is prohibited. Offenders will be held liable for the payment of damages. All rights reserved in the event of the grant of a patent, utility module or design.

Contents and general instructions

PROFIBUS, PROFIBUS-DP, PROFINET IO[®] are registered trademarks of PROFIBUS International (P.I.)

DeviceNet[®] is a registered trademark of Open DeviceNet Vendor Association. Inc. (ODVA)

RSLinx, RSLogix, RSNetworx for DeviceNet[®] are registered trademarks of Rockwell Software Inc. or Rockwell Automation

EtherNet/IP[®] is a registered trademark of ControlNet International Ltd. and the Open DeviceNet Vendor Association. Inc. (ODVA)

CC-Link[®] is a registered trade mark of Mitsubishi Electric Corp.

Interbus[®] is a registered trademark of Phoenix Contact GmbH & Co. KG, Blomberg, Germany

Contents

1.	System summary	1-1
1.1	The CPX-CM-HPP	1-3
	1.1.1 Functions and characteristics	1-3
	1.1.2 Functions	1-3
1.2	Supported motor controllers	1-4
1.3	Control possibilities	1-5
1.4	System configuration	1-6
	1.4.1 Autonomous automation solution	1-6
	1.4.2 Control of the CPX terminal through a higher-order controller	1-7
	1.4.3 Autonomous automation solution with communication with a higher-level controller	1-8
1.5	Connection and display components	1-9
2.	Fitting and installation	2-1
2.1	General installation instructions	2-3
2.2	Dismantling and mounting	2-4
	2.2.1 Dismantling	2-4
	2.2.2 Mounting	2-5
2.3	Axis connection (CAN bus interface)	2-6
2.4	Connecting the CAN bus	2-7
	2.4.1 CAN bus line	2-7
	2.4.2 Terminating resistor	2-8

3.	Commissioning	3-1
3.1	General instructions on commissioning	3-3
3.2	Communication profile FHPP	3-4
3.2.1	Overview of FHPP data structures	3-5
3.3	Communication between CPX-CM-HPP and the motor controllers	3-9
3.4	Commissioning	3-10
3.5	Parameterisation of the connected motor controllers with FCT	3-12
3.5.1	Requirement for commissioning of the motor controllers with FCT	3-12
3.5.2	Commissioning of the motor controllers	3-13
3.5.3	Specific settings for motor controllers CMMD-AS, CMMS-AS and CMMS-ST	3-14
3.5.4	Specific settings for CMMP-AS motor controller	3-16
3.5.5	Specific settings for the MTR-DCI motor unit	3-17
3.5.6	Specific settings for SFC-DC motor controller	3-18
3.5.7	Specific settings for SFC-LAC motor controller	3-18
3.5.8	Specific settings for EXCM motor controller	3-19
3.6	Configuration of the CPX-CM-HPP	3-20
3.6.1	Configuration parameter	3-20
3.6.2	Description of configuration parameters	3-21
3.6.3	Additional parameters	3-24
3.6.4	Configuration with the MMI	3-25
3.6.5	Configuration with CPX-FMT	3-27
3.7	Force	3-29
4.	Diagnosis and error treatment	4-1
4.1	Summary of diagnostics options	4-3
4.2	Errors and warnings	4-4
4.2.1	Behaviour in case of errors and warnings	4-4
4.2.2	Acknowledging errors	4-4
4.2.3	Error numbers	4-5
4.3	Diagnosis via display	4-11
4.4	Diagnosis via LEDs	4-13

Contents and general instructions

4.5	Diagnosis at the CPX terminal	4-15
4.5.1	Status bits in the system status of the CPX terminal	4-15
4.5.2	I/O diagnostic interface and diagnostics memory	4-16
4.5.3	Definition of diagnostics channels	4-19
A.	Technical appendix	A-1
A.1	Technical Data	A-3
A.2	Accessories	A-4
A.3	Device-specific information on the CPX-MMI handheld	A-5
B.	Index	B-1
	Intended use	VII
	Target group	VIII
	Service	VIII
	Important user instructions	IX
	Safety instructions	XI
	Instructions on this description	XIII
	Glossary	XV

Intended use

The CPX-CM-HPP module documented in this description is intended exclusively for use in Festo CPX terminals for installation in a machine or an automation technology system.

The CPX-CM-HPP, in combination with a controller, permits independent control of up to four drives via CAN bus.

The CPX terminal and the CPX-CM-HPP is only to be used as follows:

- As intended in an industrial environment.
- In its original condition without unauthorised modifications. Only the conversions or modifications described in the documentation supplied with the product are permitted.
- In perfect technical condition.
- Only in combination with permitted components. An overview of the supported motor controllers can be found in Tab. 1/4.

The limit values specified for pressures, temperatures, electrical data, torques etc. should be observed.

Observe the regulations of the trade associations, German Technical Control Board (TÜV), VDE specifications or relevant national regulations.

Target group

This description is intended exclusively for technicians trained in control and automation technology, who have experience in installing, commissioning, programming and diagnosing positioning systems.

Service

Please consult your local Festo Service agent if you have any technical problems.

Important user instructions

Danger categories

This manual contains instructions on the possible dangers which may occur if the product is not used correctly. These instructions are marked (Warning, Caution, etc.), printed on a shaded background and marked additionally with a pictogram. A distinction is made between the following danger warnings:



Warning

This means that failure to observe this instruction may result in serious personal injury or damage to property.



Caution

This means that failure to observe this instruction may result in personal injury or damage to property.



Note

This means that failure to observe this instruction may result in damage to property.

The following pictogram marks passages in the text which describe activities with electrostatically sensitive components.



Electrostatically sensitive components may be damaged if they are not handled correctly.

Marking special information

The following pictograms mark passages in the text containing special information.

Pictograms



Information:
Recommendations, tips and references to other sources of information.



Accessories:
Information on necessary or sensible accessories for the Festo product.



Environment:
Information on environment-friendly use of Festo products.

Text markings

- The bullet indicates activities which may be carried out in any order.
- 1. Figures denote activities which must be carried out in the numerical order specified.
- Hyphens indicate general activities.

Square brackets designate menu entries.
Example: [Configuration].

Angle brackets mark position holders for designations.
Example: “Status of <Your Connection>”.

Quotation marks designate names of windows, dialogues and buttons. Example: “Status of <Your Connection>”.

Safety instructions



Protection against dangerous movements

Warning

High forces of acceleration at the connected actuators! Accidental movements can cause collisions and severe injuries.

Dangerous movements can occur through faulty control of connected actuators, e.g. via:

- unsafe or faulty wiring or cabling,
- faulty operation of the components,
- errors in the measured value and signal generators,
- faulty or non-EMC-compliant components,
- errors in the higher-order control system,

Simply switching off the compressed air supply or load voltage are not suitable locking procedures. In the event of a malfunction, this could lead to unintentional movement of the drive.

- Before doing mounting, installation and service work, bring the system into a safe condition (e.g. by bringing the drive into a safe position and deactivating the controller).

Always make sure that the compressed air supply and power supply are switched off and locked when working in the machine area.

- Make sure that no persons are in the sphere of influence of the drives or any other connected actuators.
- Do not switch on the compressed air supply until the system is correctly installed and parameterised.

- Holding brakes controlled by the drive controller alone are not suitable to ensure personal protection!
Secure vertical axes from falling or sliding down when the compressed air and load voltage are switched off, as follows:
 - mechanical locking of the vertical axis,
 - external braking/safety catch/clamping device or
 - sufficient counterbalance of the axis.
- Additional measures are required for use in safety-related applications; in Europe, for example, the standards listed under the EC Machinery Directive must be observed. Without additional measures in accordance with statutory minimum requirements, the product is not suitable for use in safety-related sections of control systems.

Protection from pressurised lines



Caution

Danger of injury through improper handling of pressurised lines!

Uncontrolled movements of the connected actuators and uncontrollable movements of loose tubing lines can cause injury to people or material damage.

- Do not disconnect, open or cap pressurised lines.
- The lines must always be vented before removal (release compressed air).
- Use appropriate protective equipment (for instance safety goggles, safety shoes, etc.).

Instructions on this description



Note

This description refers to the module CPX-CM-HPP from Revision 01.

You will find the revision on the rating plate



This description contains specific information on the mode of operation, mounting, installation and commissioning of the CPX-CM-HPP.

Additional information on the CPX-CM-HPP can be found in the following documentation.

Document	Contents
Brief description of the CPX-CM-HPP, P.BE-K-CPX-CM-HPP	Information on mounting and installation of the CPX-CM-HPP.

Tab. 0/1: Overview of additional documentation on the CPX-CM-HPP

You will find additional information on the CPX terminal in the following documentation.

Type	Title	Description
Description Electronics	“System description” P.BE-CPX-SYS-... 	Overview of structure, components and mode of operation of CPX terminals; installation and commissioning instructions as well as basic principles of parametrisation
	“CPX fieldbus node” P.BE-CPX-FB... 	Instructions for the assembly, installation, commissioning and diagnostics of the corresponding fieldbus node

Tab. 0/2: Extract from the overview of additional documentation on the CPX terminal

Glossary

The following product-specific terms and abbreviations are used in this description:

Term/abbreviation	Significance
0-Signal	Input or output delivers 0 V (also LOW, FALSE or logic 0).
1-Signal	Input or output provides 24 V (also HIGH, TRUE or logic 1).
0xA0 A0 _h	Hexadecimal numbers are marked by a prefixed "0x" or by a lowered "h". Example: 0xA0 = A0 _h = 160 decimal.
Axis	Motor controller, linear/rotative axis, motor and gear unit
Axis connection	Interface of the CPX-CM-HPP for connection of the motor controllers via CAN bus.
Control	Control of the CPX terminal and the CPX-CM-HPP takes place through: <ul style="list-style-type: none"> – a higher-order controller <li style="padding-left: 20px;">a controller connected via fieldbus to the CPX terminal – CPX-FEC or CPX-CEC-...: <li style="padding-left: 20px;">a controller integrated into the CPX terminal
CPX-CEC-...	The CoDeSys controller as CPX module. Controller that can be integrated into the CPX terminal.
CPX-FEC	Front-end controller as CPX module. Controller that can be integrated into the CPX terminal.
CPX module	Collective term for the various modules which can be integrated into a CPX terminal.
CPX terminal	Complete system comprising CPX modules.
FE	Functional earth
FHPP	Festo Handling and Positioning Profile
Fieldbus node	Provides the connection to specific fieldbuses. Transmits control signals to the connected modules and monitors their functioning (as a CPX module: CPX fieldbus node).
Handheld CPX-MMI	Handheld terminal for commissioning and service purposes
I	Digital input
I/Os	Digital inputs and outputs

Term/abbreviation	Significance
O	Digital output
OB	Output byte
Parameter	Parameters which must be set so that the system can be operated.
RSB	Record status byte

Tab. 0/3: Terms and abbreviations

System summary

Chapter 1

1. System summary

Contents

1.	System summary	1-1
1.1	The CPX-CM-HPP	1-3
	1.1.1 Functions and characteristics	1-3
	1.1.2 Functions	1-3
1.2	Supported motor controllers	1-4
1.3	Control possibilities	1-5
1.4	System configuration	1-6
	1.4.1 Autonomous automation solution	1-6
	1.4.2 Control of the CPX terminal through a higher-order controller	1-7
	1.4.3 Autonomous automation solution with communication with a higher-level controller	1-8
1.5	Connection and display components	1-9

1. System summary

1.1 The CPX-CM-HPP

The CPX-CM-HPP is an interface for electric positioning and handling axes in the CPX System by Festo.

Programming of the CPX-CM-HPP is not required for this. The following options are available for configuration:

- MMI
- FMT
- EDS file
- GSD file
- Programming software of the CPX Front End Controller

1.1.1 Functions and characteristics

The CPX-CM-HPP is designed for up to 4 axes. The axes are connected on the front side via the CAN bus interface (M9, 5-pin). The motor controllers are configured with the Festo Configuration Tool FCT.

The motor controllers are controlled by a higher-order controller via a CPX fieldbus node or through the CPX-FEC or CPX-CEC-... controller integrated into the CPX terminal. The CPX-CM-HPP merely passes on the I/O data. The Festo data profile FHPP is used for communication.

1.1.2 Functions

The CPX -CM-HPP takes over the following functions:

- Transfer of control and status data between the controller and the connected motor controllers.
- Malfunction management

1. System summary

1.2 Supported motor controllers

The CPX-CM-HPP supports the following motor controllers:

Motor controller	Comment
CMMS-AS	–
CMMS-ST	–
CMMP-AS	–
Motor unit MTR-DCI	–
SFC-DC	–
SFC-LAC	–
CMMD-AS	–
EXCM	–

Tab. 1/4: Supported motor controllers
(Status September 2014)

1. System summary

1.3 Control possibilities

The CPX-CM-HPP can be controlled in the following ways:

- Through a higher-order controller using a CPX fieldbus node

or

- Control through a front-end controller in the CPX terminal

Communication with the controller takes place over the Festo data profile FHPP (32-byte input and output data, 8 bytes per axis).



Detailed information on the Festo data profile FHPP is provided in the P.BE-CMM-FHPP-SW-... description.

The following software versions of the CPX modules are required to operate the CPX-CM-HPP:

CPX module	Required version ¹⁾	Comment
CPX-FB11 (DeviceNet)	from Revision 22	–
CPX-FB13 (PROFIBUS)	from Revision 23	–
CPX-FEC	from Revision 16	–
¹⁾ Software version (SW) see rating plate		

Tab. 1/5: Required software versions (Status September 2014)



Observe the following when using the CPX-CM-HPP:

- When using two CPX-CM-HPP in one CPX terminal, you must deactivate the diagnostic byte.
- The CAN bus setting node ID: Default 1 cannot be changed.

1. System summary

1.4 System configuration

1.4.1 Autonomous automation solution

- 1 CPX terminal with CPX-FEC/CPX-CEC-... and CPX-CM-HPP
- 2 CAN bus
- 3 CMMS
- 4 EMMS
- 5 SFC-DC
- 6 SLTE
- 7 MTR-DCI

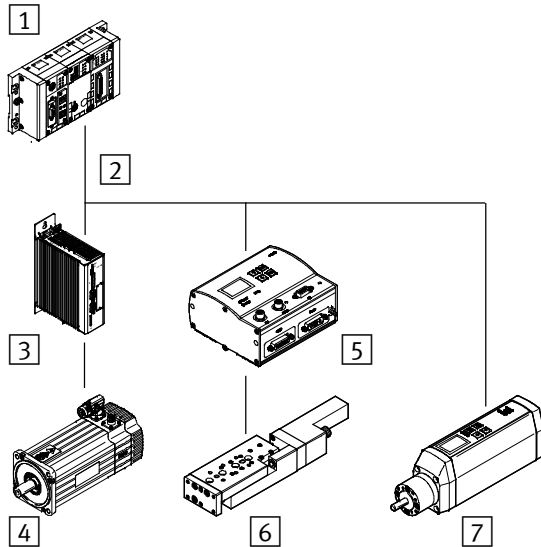

Fig. 1/1: Autonomous automation solution with CPX terminal, CPX-FEC/CPX-CEC-... and CPX-CM-HPP

In this configuration, the sequence control of the CPX terminal is taken over by the CPX-FEC/CPX-CEC-. Communication takes place over the Festo data profile FHPP.

1. System summary

1.4.2 Control of the CPX terminal through a higher-order controller

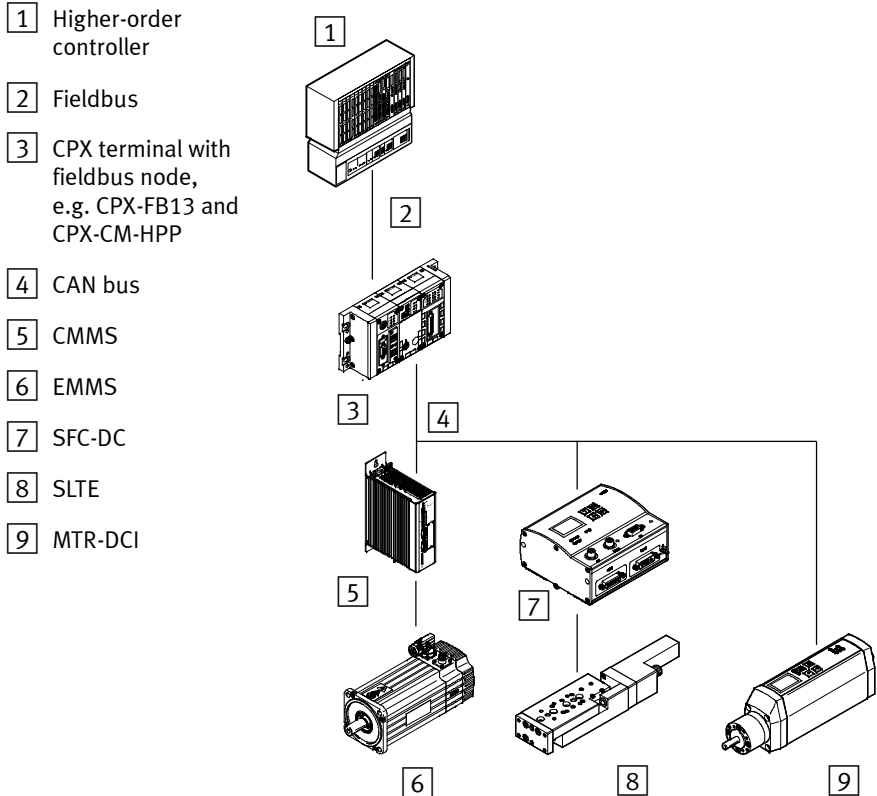

Fig. 1/2: Design of CPX terminal with higher-order controller

In this configuration, the sequence control of the CPX terminal is taken over by a higher-level controller. Communication takes place over the Festo data profile FHPP.

1. System summary

1.4.3 Autonomous automation solution with communication with a higher-level controller

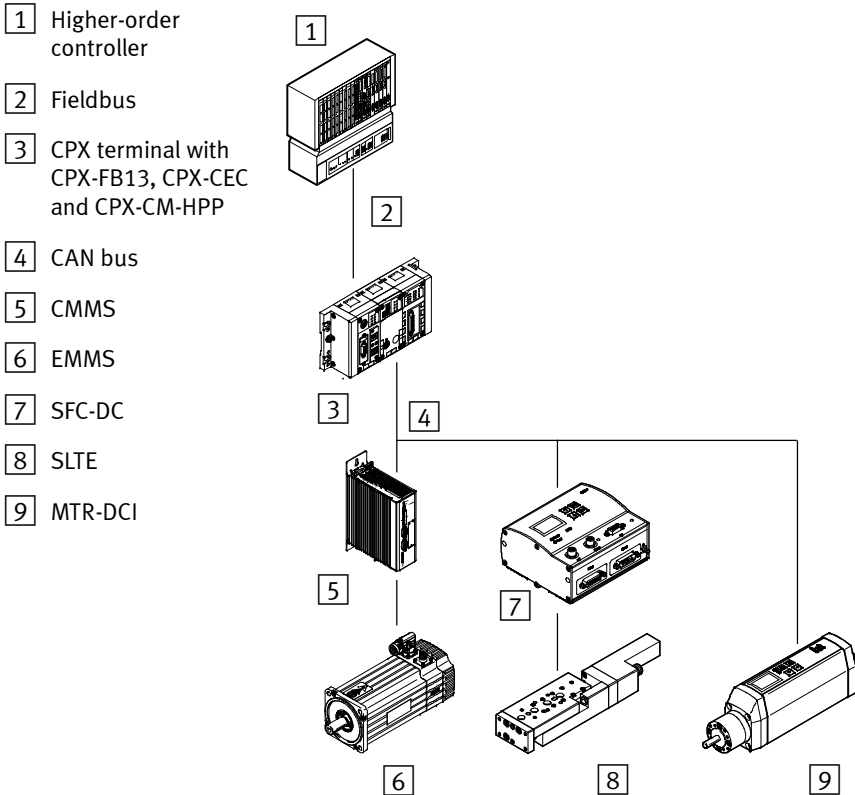

Fig. 1/3: Design of autonomous automation solution with communication with a higher-level controller

In this configuration, the sequence control of the CPX terminal is taken over by the CPX-FEC. Communication takes place over the Festo data profile FHPP.

1. System summary

1.5 Connection and display components

The following connection and display components can be found on the CPX-CM-HPP:

- 1 Status LEDs, see section 4.4
- 2 X: Axis connection
- 3 Inscription labels (accessories)
- 4 3-character display, see section 4.3
- 5 Rating plate see side

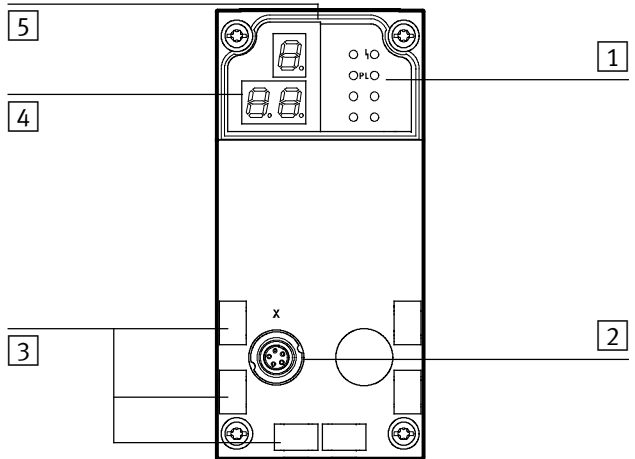

Fig. 1/4: Connection and display components on the CPX-CM-HPP

- 6 1st position (e.g. code letters for parameters or status type)
- 7 Point for separation
- 8 2nd and 3rd position (e.g. value, step or status information)

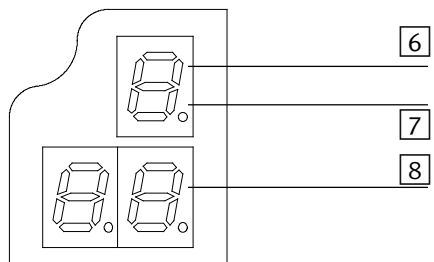

Fig. 1/5: Display/7-segment display

1. System summary

Fitting and installation

Chapter 2

2. Fitting and installation

Contents

2.	Fitting and installation	2-1
2.1	General installation instructions	2-3
2.2	Dismantling and mounting	2-4
	2.2.1 Dismantling	2-4
	2.2.2 Mounting	2-5
2.3	Axis connection (CAN bus interface)	2-6
2.4	Connecting the CAN bus	2-7
	2.4.1 CAN bus line	2-7
	2.4.2 Terminating resistor	2-8

2. Fitting and installation

2.1 General installation instructions



Warning

Before carrying out installation and maintenance work, switch off the following:

- if applicable, the compressed air supply
- the operating voltage supply for the electronics/sensors
- the load voltage supply for the outputs/valves

In this way, you can avoid:

- uncontrolled movements of loose tubing lines
- uncontrolled movements of the connected actuators
- undefined switching states of the electronics



Caution

The CPX-CM-HPP contains electrostatically sensitive devices.

- Therefore, do not touch any components.
- Observe the handling specifications for electrostatically sensitive devices.

They will help you avoid damage to the electronics.

Information about mounting the CPX terminal can be found in the CPX system description (P.BE-CPX-SYS-...).

Information on mounting the components of the positioning system can be found in the related components documentation.

2. Fitting and installation

2.2 Dismantling and mounting

The CPX-CM-HPP is mounted in an interlinking block of the CPX terminal (see Fig. 2/1).

- 1 CPX-CM-HPP
- 2 Interlinking block
- 3 Contact rails
- 4 Screws,
Tightening torque
0.9 ... 1.1 Nm

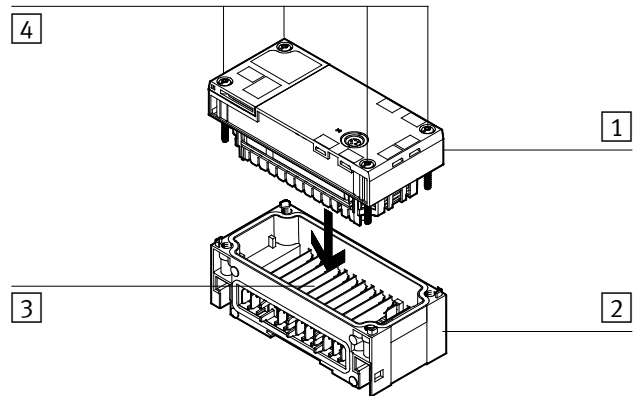

Fig. 2/1: Dismantling/mounting of the CPX-CM-HPP

2.2.1 Dismantling

Dismantle the CPX-CM-HPP as follows:

1. Loosen the 4 screws of the CPX-CM-HPP.
2. Pull the CPX-CM-HPP carefully and without tilting away from the contact rails of the interlinking block.

2. Fitting and installation

2.2.2 Mounting

Mount the CPX-CM-HPP as follows:

1. Set the CPX-CM-HPP in the interlinking block. Make sure that the corresponding grooves with the power contact terminals on the bottom of the CPX-CM-HPP lie above the contact rails.
2. Press the CPX-CM-HPP carefully and without tilting into the interlinking block up to the stop.
3. Set the screws so that the self-cutting threads can be used.
4. Tighten the screws by hand in diagonally opposite sequence. Tightening torque 0.9 ... 1.1 Nm

2. Fitting and installation

2.3 Axis connection (CAN bus interface)

The motor controllers of the positioning system are connected via the CAN bus to the axis connection of the CPX-CM-HPP.

CAN bus parameters:

- Transmission rate: 1 Mbit/s
- Data profile: FHPP
- Max. line length: 30 m

The axis connection of the CPX-CM-HPP is designed as a 5-pin M9 socket:

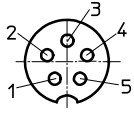
M9 socket	Pin	Signal	Wire colour ¹⁾	Explanation
	1	n.c.		Not connected
	2	n.c.		Not connected
	3	CAN_GND	Green	CAN Ground
	4	CAN_H	White	CAN High
	5	CAN_L	Brown	CAN Low
	Housing			

1) When using a connecting cable with open end, e.g. NEBC-M9W5-K-5-N-LE3.

Tab. 2/6: Pin allocation of the CAN bus interface



The CPX-CM-HPP does not provide power supply to the connected CAN bus stations via the CAN bus interface.

2.4 Connecting the CAN bus

2.4.1 CAN bus line



Note

In case of faulty installation or high transmission rates, data transmission errors can occur as a result of signal reflections and attenuations.

Transmission errors can be caused by:

- missing or incorrect terminating resistor
- incorrect screened connection
- branches
- large distances
- unsuitable cables

Use a connecting cable from Festo with open end, e.g. NEBC-M9W5-K-5-N-LE3, as the CAN bus line between CPX-CM-HPP and the first motor controller.

Use a twisted, screened 4-wire cable as CAN bus line between the motor controllers. A CAN bus plug is available as an accessory (→ www.festo.com/catalogue) to connect the motor controller.

If the Festo CAN bus plug is used, a cable diameter of 5 ... 8 or 7 ... 10 mm is permitted.



Note

If the CPX terminal is mounted movably in a machine, the CAN bus line on the movable part must be provided with strain relief. Also observe the relevant regulations in EN 60204 part 1.

2. Fitting and installation

2.4.2 Terminating resistor

A CAN bus terminating resistor is integrated into the axis connection of the CPX-CM-HPP.

A CAN bus terminating resistor of 120 ohms must be installed at the other end of the CAN bus. Depending on the drive, this terminating resistor is integrated into the drive and activated via DIP switches. If the drive does not have an integrated terminating resistor, it must be manually connected between the signals CAN-H (High) and CAN-L (Low).

Commissioning

Chapter 3

Contents

3.	Commissioning	3-1
3.1	General instructions on commissioning	3-3
3.2	Communication profile FHPP	3-4
3.2.1	Overview of FHPP data structures	3-5
3.3	Communication between CPX-CM-HPP and the motor controllers	3-9
3.4	Commissioning	3-10
3.5	Parameterisation of the connected motor controllers with FCT	3-12
3.5.1	Requirement for commissioning of the motor controllers with FCT	3-12
3.5.2	Commissioning of the motor controllers	3-13
3.5.3	Specific settings for motor controllers CMMD-AS, CMMS-AS and CMMS-ST	3-14
3.5.4	Specific settings for CMMP-AS motor controller	3-16
3.5.5	Specific settings for the MTR-DCI motor unit	3-17
3.5.6	Specific settings for SFC-DC motor controller	3-18
3.5.7	Specific settings for SFC-LAC motor controller	3-18
3.5.8	Specific settings for EXCM motor controller	3-19
3.6	Configuration of the CPX-CM-HPP	3-20
3.6.1	Configuration parameter	3-20
3.6.2	Description of configuration parameters	3-21
3.6.3	Additional parameters	3-24
3.6.4	Configuration with the MMI	3-25
3.6.5	Configuration with CPX-FMT	3-27
3.7	Force	3-29

3. Commissioning

3.1 General instructions on commissioning



Caution

Switch on the operating voltage supply and the compressed air only when installation of the entire system has been completely finished without errors.



Warning

Danger of collisions with serious injuries due to uncontrolled movements of the actuators.

- Be very careful when the axes are moving (e.g. teaching positions, jogging, homing).
- Make sure that no persons are in the sphere of influence of the drives or any other connected actuators.

Information about commissioning the CPX terminal can be found in the CPX system description (P.BE-CPX-SYS-...).

Information on commissioning the components of the positioning system, motor controllers, motors and axes can be found in the related components documentation.

3.2 Communication profile FHPP

Festo has developed an optimised data profile, the “Festo Handling and Positioning Profile (FHPP)” tailored to handling and positioning tasks.

The FHPP enables uniform control and programming for the various fieldbus systems and controllers from Festo.

In addition it defines the following for the user:

- operating modes,
- I/O data structure,
- parameter objects,
- sequence control.

An overview of the I/O data structure can be found in section 3.2.1.

Detailed information on the FHPP can be found in the respective documentation of the motor controllers.



3. Commissioning

3.2.1 Overview of FHPP data structures

The subsequent description of the telegram design for communication with the CPX-CM-HPP shows the allocation of the bytes. The FHPP profile for the CPX-CM-HPP differs in some positions from the standard FHPP.



Detailed information on the FHPP can be found in the respective documentation of the motor controllers.

Record select operating mode								
	Byte 1	Byte 2	Byte 3	Byte 4	Byte 5	Byte 6	Byte 7	Byte 8
O-data X-axis	CCON	CPOS	Record no.	Reserved	Reserved			
I-data X-axis	SCON	SPOS	Record no.	RSB	Actual position			
	Byte 9	Byte 10	Byte 11	Byte 12	Byte 13	Byte 14	Byte 15	Byte 16
O-data Y-axis	CCON	CPOS	Record no.	Reserved	Reserved			
I-data Y-axis	SCON	SPOS	Record no.	RSB	Actual position			
	Byte 17	Byte 18	Byte 19	Byte 20	Byte 21	Byte 22	Byte 23	Byte 24
O-data Z-axis	CCON	CPOS	Record no.	Reserved	Reserved			
I-data Z-axis	SCON	SPOS	Record no.	RSB	Actual position			
	Byte 25	Byte 26	Byte 27	Byte 28	Byte 29	Byte 30	Byte 31	Byte 32
O-data U-axis	CCON	CPOS	Record no.	Reserved	Reserved			
I-data U-axis	SCON	SPOS	Record no.	RSB	Actual position			

3. Commissioning

Direct mode operating mode								
	Byte 1	Byte 2	Byte 3	Byte 4	Byte 5	Byte 6	Byte 7	Byte 8
O-data X-axis	CCON	CPOS	CDIR	Setpoint value 1 (speed)	Setpoint value 2 (position, force, torque,...)			
I-data X-axis	SCON	SPOS	SDIR	Actual value 1 (speed)	Actual value 2 (actual position, actual force, actual torque, ...)			
	Byte 9	Byte 10	Byte 11	Byte 12	Byte 13	Byte 14	Byte 15	Byte 16
O-data Y-axis	CCON	CPOS	CDIR	Setpoint value 1 (speed)	Setpoint value 2 (position, force, torque, ...)			
I-data Y-axis	SCON	SPOS	SDIR	Actual value 1 (speed)	Actual value 2 (actual position, actual force, actual torque, ...)			
	Byte 17	Byte 18	Byte 19	Byte 20	Byte 21	Byte 22	Byte 23	Byte 24
O-data Z-axis	CCON	CPOS	CDIR	Setpoint value 1 (speed)	Setpoint value 2 (position, force, torque, ...)			
I-data Z-axis	SCON	SPOS	SDIR	Actual value 1 (speed)	Actual value 2 (actual position, actual force, actual torque, ...)			
	Byte 25	Byte 26	Byte 27	Byte 28	Byte 29	Byte 30	Byte 31	Byte 32
O-data U-axis	CCON	CPOS	CDIR	Setpoint value 1 (speed)	Setpoint value 2 (position, force, torque, ...)			
I-data U-axis	SCON	SPOS	SDIR	Actual value 1 (speed)	Actual value 2 (actual position, actual force, actual torque, ...)			

3. Commissioning

Control bytes

	B7	B6	B5	B4	B3	B2	B1	B0
	OPM2	OPM1	LOCK		RESET	BRAKE	STOP	ENABLE
CCON	Operating mode selection		MMI access blocked		Acknowledge malfunction	Release brake	Stop	Enable drive

	B7	B6	B5	B4	B3	B2	B1	B0
		CLEAR	TEACH	JOGN	JOGP	HOM	START	HALT
CPOS		Delete remaining path	Teach value	Jog negative	Jog positive	Start reference travel	Start positioning job	Halt

	B7	B6	B5	B4	B3	B2	B1	B0
	FUNC	FAST	XLIM	CTOG	CONT	COM2	COM1	ABS
CDIR	Execute function	Exact stop/quick stop	Stroke limit value deactivated	Tracking mode toggle bit	Tracking mode	Control mode (position, force, torque, speed)		Absolute/relative



The functions of the individual bits of the CDIR byte can deviate from the above definition, depending on the drive. You can find the valid definition in the system description of the respective drives.

3. Commissioning

Status bytes

	B7	B6	B5	B4	B3	B2	B1	B0
	OPM2	OPM1	LOCK	24VL	FAULT	WARN	OPEN	ENABLED
SCON	Operating mode acknowledgment		Higher-order controller FCT/MMI	Load voltage applied	Malfunction	Warning	Operation enabled	Drive enabled

	B7	B6	B5	B4	B3	B2	B1	B0
	REF	STILL	DEV	MOV	TEACH	MC	ACK	HALT
SPOS	Drive referenced	Standstill monitoring	Following error	Axis moves	Acknowledge teach	Motion complete	Acknowledge start	Halt

	B7	B6	B5	B4	B3	B2	B1	B0
	FUNC	FAST	XLIM	VLIM	CONT	COM2	COM1	ABS
SDIR	Function is executed	Exact stop/quick stop	Stroke limit reached	Speed limit reached	Tracking mode	Acknowledgment control mode (position, force, torque, speed)		Absolute/relative



The functions of the individual bits of the SDIR byte can deviate from the above definition, depending on the drive. You can find the valid definition in the system description of the respective drives.

3. Commissioning

3.3 Communication between CPX-CM-HPP and the motor controllers

Communication between CPX-CM-HPP and the motor controllers takes place over the following interface:

Parameter	Setting
Interface	CANopen
Data profile	FHPP
Bit rate	1000 kbit/s or 1 Mbit/s
CAN address	2 ... 9

Tab. 3/1: Parameter of the interface

3.4 Commissioning

1. First, place the drives into operation as single axes over the FCT with the respective plug-in. Observe the required settings for communication via CAN bus (see chapter 3.5).
2. Configure the CPX-CM-HPP in accordance with the drives (drive type, CAN address, data format, see chapter 3.6). Adjust the start mode so that the system starts with the stored parameters (see CPX system description P.BE-CPX-SYS-...).
3. Switch the CPX terminal off.
4. Connect the CPX-CM-HPP with the drives via a CAN bus cable (see www.festo.com/catalogue). Make sure that the bus terminal on the drive side is activated at the last station.
5. Switch the CPX terminal on.
The firmware version, e.g. Version 1.22, is displayed on the three-digit 7-segment display (see Fig. 1/5):

1 st position	2 nd position	3 rd position	Significance
1	2	2	Firmware version 1.22

The CPX-CM-HPP begins with initialization of the drives, e.g. with axis 1:

1 st position	2 nd position	3 rd position	Significance
1	i	n	Initialization of axis 1

If initialization has run correctly, all motor controllers are in status S0 and are ready for operation.

3. Commissioning

Errors during initialization

In case of errors, initialization stops with the defective axis. The error numbers are permanently displayed, e.g.

1 st position	2 nd position	3 rd position	Significance
4	E (=error)	1	Axis 4 shows error 1



Initialization is continued only after the error is eliminated. An overview of the error numbers can be found in chap. 4.2.3.

Errors after initialization

Errors that occur during operation are depicted with a changing display. First the error type is displayed (error or warning), then the error number. The display duration is in each case approx. 0.5 s. The following example depicts the display for error 44 at axis 1:

1 st position	2 nd position	3 rd position	Significance
1	E (=error) u (=warning)		Axis 1 shows error type “error” or “warning”
1	4	4	Axis 1 shows error 44



An overview of the error numbers can be found in chap. 4.2.3.

3.5 Parameterisation of the connected motor controllers with FCT



The subsequent information takes into account only a general procedure for commissioning of the motor controllers and the specific settings of the motor controllers for use in positioning systems with CPX-CM-HPP. Information on other settings can be found in the documentation and online help for the respective motor controller.

3.5.1 Requirement for commissioning of the motor controllers with FCT

You will need the following software packages and accessories for commissioning of the motor controllers:

- PC with FCT software and the respective plug-ins for the motor controllers
- Serial programming cable for connecting the motor controller to the PC, with special connections, depending on the device, e.g. for motor unit MTR-DCI
- System descriptions of the respective equipment

3. Commissioning

3.5.2 Commissioning of the motor controllers

**Note**

Carry out the following instructions for each motor controller.

1. Connect the PC and the motor controller with a serial programming cable.
2. Start the FCT software and follow the instructions in the FCT and in the operating instructions of the respective motor controller.
3. Make sure that the limit switches work properly
4. Check the following parameters
 - Maximum travel distances
 - Maximum travel speed
 - Maximum acceleration or deceleration
 - Translation factor for position and speed
 - Software limit switch
 - Type of homing
5. Edit the positioning record table if you want to operate the drive in the record selection mode
6. Save your settings in the controller (download -> save) and in the project (save)

The subsequent chapters describe the specific parameters for the respective drives for operation with CPX-CM-HPP.

3. Commissioning

3.5.3 Specific settings for motor controllers CMMD-AS, CMMS-AS and CMMS-ST

Menu/Tab	Parameter	Value
[Application data] [Operating mode selection]	Control interface	CANopen
[Controller][Fieldbus] [Interface parameter]	Data profile	FHPP
[Controller][Fieldbus] [Factor group]	Used	activated
	Unit	mm for linear axes ° for rotative axes
	Exponent Position	10 ⁻³
	Exponent Velocity	10 ⁻³
	Exponent Accel.	10 ⁻³

Tab. 3/2: Specific settings for motor controllers CMMD-AS, CMMS-AS and CMMS-ST

Make the following settings via the DIP switches of the motor controllers:

Parameter	Setting
Bus terminal	On/off
Bit rate	1000 kbit/s
CAN address	2 ... 9

Tab. 3/3: Settings for motor controllers CMMD-AS, CMMS-AS and CMMS-ST

3. Commissioning



CAN adress for CMMD-AS:

The CAN address of the first controller is set in CMMD-AS. The CAN address of the first controller + 1 is automatically assigned to the second controller.

With selection of the CMMD-AS, only one controller of the CMMD-AS is assigned to an axle. If the second controller of the CMMD-AS should be assigned to an axle, a CMMD must also be assigned to this axle.



You can find further information in the documentation of the motor controllers.

3. Commissioning

3.5.4 Specific settings for CMMP-AS motor controller

Menu/Tab	Parameter	Value
[Application data] [Operating mode selection]	Control interface	CANopen
[Controller]	Enable logic Enabled with	DIN5 and fieldbus
[Controller][Fieldbus] [Operating parameter]	Bit rate	1000 kbit/s
	Node number	CAN address of the axis, see Tab. 3/1
	Protocol	Festo FHPP
[Controller][Fieldbus] [Factor group]	Used	activated
	Unit	mm for linear axes ° for rotative axes
	Exponent Position	10 ⁻³
	Exponent Velocity	10 ⁻³
	Exponent Accel.	10 ⁻³

Tab. 3/4: Specific settings for CMMP-AS motor controller

3. Commissioning

3.5.5 Specific settings for the MTR-DCI motor unit

Menu/Tab	Parameter	Value
[Configuration]	Motor type	MTR-DCI-...-CO
[Motor][Control interface] [Interface parameter]	CAN address	CAN address of the axis, see Tab. 3/1
	Bit rate	1 Mbit/s
	Data profile	FHPP
	Supply voltage	internal With the “external” option, an external supply voltage must be connected to the CAN bus plug; see system description of the motor unit MTR-DCI.

Tab. 3/5: Specific settings for the MTR-DCI motor unit

3. Commissioning

3.5.6 Specific settings for SFC-DC motor controller

Menu/Tab	Parameter	Value
[Configuration]	Controller type	SFC-DC-...-CO
[Controller][Interface] [Interface parameter]	CAN address	CAN address of the axis, see Tab. 3/1
	Bit rate	1 Mbit/s
	Data profile	FHPP
	Supply voltage	internal With the “external” option, an external supply voltage must be connected to the CAN bus plug; see system description of the motor controller.

Tab. 3/6: Specific settings for SFC-DC motor controller

3.5.7 Specific settings for SFC-LAC motor controller

Menu/Tab	Parameter	Value
[Configuration]	Controller type	SFC-LAC-...-CO (CANopen)
[Controller][Interface] [Interface parameter]	CAN address	CAN address of the axis, see Tab. 3/1
	Bit rate	1 Mbit/s
	Data profile	FHPP
	Supply voltage	With the “external” option, an external supply voltage must be connected to the CAN bus plug; see system description of the motor controller.

Tab. 3/7: Specific settings for SFC-LAC motor controller

3. Commissioning

3.5.8 Specific settings for EXCM motor controller

Menu/Tab	Parameter	Value
[Configuration]	Controller type	EXCM
[Controller]	CAN address	CAN address of the axis, see Tab. 3/1
	Bit rate	1 Mbit/s
	Data profile	FHPP

Tab. 3/8: Specific settings for EXCM motor controller

3.6 Configuration of the CPX-CM-HPP

3.6.1 Configuration parameter

For each module, 64 byte module parameters can be entered in the system table of the CPX terminal. Function number $4828 + m * 64 + 0 \dots 63$ (m = module number in the CPX terminal).

Function number	Parameter entry	
$4828 + m * 64 + 6$	Axis 1	Axis type ¹⁾
$4828 + m * 64 + 7$		Node ID
$4828 + m * 64 + 8$		Format
$4828 + m * 64 + 9$	Axis 2	Axis type ¹⁾
$4828 + m * 64 + 10$		Node ID
$4828 + m * 64 + 11$		Format
$4828 + m * 64 + 12$	Axis 3	Axis type ¹⁾
$4828 + m * 64 + 13$		Node ID
$4828 + m * 64 + 14$		Format
$4828 + m * 64 + 15$	Axis 4	Axis type ¹⁾
$4828 + m * 64 + 16$		Node ID
$4828 + m * 64 + 17$		Format
¹⁾ There must be no gaps in the list. Axis type = "No Axis" is the end of the list.		

Tab. 3/9: Function number 4828 – configuration parameters

The configuration parameters are stored in the EEPROM of the CPX-CM-HPP. The parameters Axis Type and Node ID only become effective after the next Power On. The saved configuration parameters are loaded as "default parameters"

3. Commissioning

during switch-on if the system parameter “System starts with default parameter” is selected in the CPX fieldbus node or CPX-FEC.

3.6.2 Description of configuration parameters

Axis type

Value	Significance
0	No axis (axis not on hand)
1	Motor controller CMMP-AS
2	Motor controller CMMS-AS
3	Motor controller CMMS-ST
4	Motor unit MTR-DCI
5	Motor controllers SFC-DC
6	Motor controller SFC-LAC
7	Motor controller EXCM
8	Motor controller CMMD-AS

Tab. 3/10: Axis Type configuration parameter

Node ID

CAN bus address of the motor controller

Range of values: from 2 to 9

3. Commissioning

Format

Input and output format of the position value

Valid for:

- Actual position
- Setpoint position in the direct mode



Warning

Danger of injury to people and material damage.
If format specifications are set incorrectly, the setpoint position can deviate from the real positions.

- Check the format specifications carefully.

Value	Format	Significance
0	32 bit [Ink]	Only for CMMx-xx motor controller: original 32 bit long integer of the motor controller. When the factor group for motor controller CMMx-xx is used, this 32 bit value represents the path (e.g. μm) dependent on the set resolution (e.g. 10^{-3}).
1	32 bit [μm]	Only for motor unit MTR-DCI and motor controller SFC-xx: The 32-bit position value is converted into [μm] or [$1/1000^\circ$].

3. Commissioning

Value	Format	Significance			
2	BD/AD [mm]	If a 16-bit controller is used, e.g. CPX-FEC: for MTR-DCI and SFC-xx, the position value is first converted into [μm] or [1/1000°] and then into before decimal word (BD) and after decimal word (AD).			
		Position value [μm] or [1/1000°]	Position value [mm] or [°]	BD	AD
		245987	245,987	245	987
		1234034	1234,034	1234	34
		-200065	-200,065	-200	65
-345	-0,345	0	-345		

Tab. 3/11: Configuration parameter Format



Two words are used when a controller with an address range > 65536 is used. A conversion into hexadecimal values is required; see following example:

245987 = 0x3C0E3

Byte 4.5 (FHPP): 0xC0E3

Byte 6.7 (FHPP): 0x0003

Conversion is not necessary when a higher-level fieldbus master and double words are used.



If a Profibus control is used, attention must be paid that the bytes are correctly transferred. The bytes might be transposed.

3. Commissioning

3.6.3 Additional parameters

Function number	Parameter	Value	Comment
$16 + 16 * m + 0$	Module code	175	Entry in the CPX system table.
$16 + 16 * m + 13$	Version	0 ... 255	Shows the output status (version) of the module corresponding to the rating plate.
$784 + m * 4 + 0$	Serial number		Byte 0: includes the year and month of the series.
$784 + m * 4 + 1$			The bytes 1 ... 3 include per nibble a digit of the serial number (BCD coded).
$784 + m * 4 + 2$			
$784 + m * 4 + 3$			

Tab. 3/12: Additional parameters

3. Commissioning

3.6.4 Configuration with the MMI

Requirements

If you use a system structure with a fieldbus slave as CPX master:

- Set the parameter “System start” (path: “CPX Terminal/System parameters/System start”) to “Saved parameters” one time.

If the parameter “System start” is set to “Default parameters”, the default parameters are loaded. The default parameters can deviate from the current system configuration.

Configuration

In the [Parameters] menu, the configuration parameters of the CPX-CM-HPP are displayed and revised.



You can find the description of the possible settings in chapter 3.6.1.

In the [Parameters] menu, the configuration parameters of the CPX-CM-HPP are displayed and changed.

- After parametrisation, carry out a restart of the CPX terminal to accept the revised parameters.

3. Commissioning

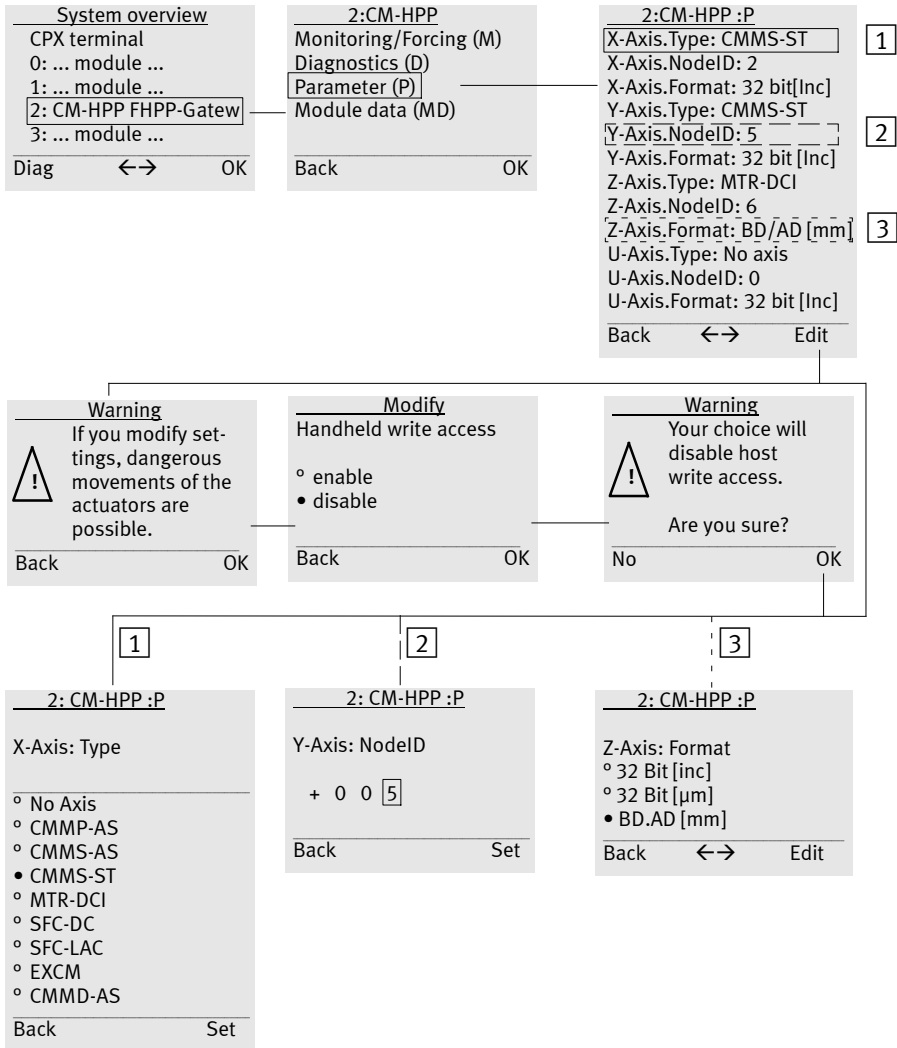

Fig. 3/2: Display configuration parameters and change with the CPX-MMI

3. Commissioning

3.6.5 Configuration with CPX-FMT

The following illustrations show the configuration of the CPX-CM-HPP with CPX-FMT.

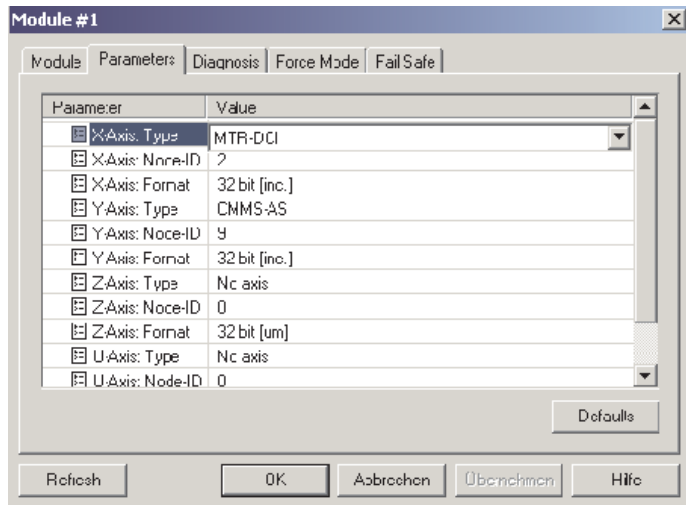

Fig. 3/3: Configuration with FMT: Axis selection

3. Commissioning

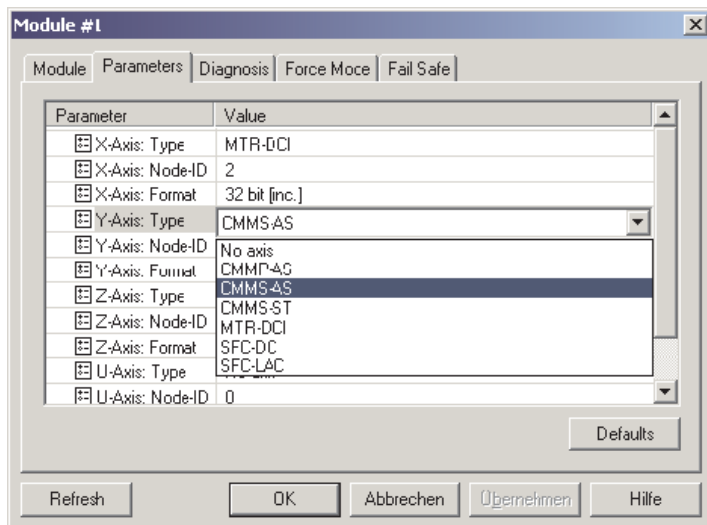

Fig. 3/4: Configuration with FMT: Axis type selection

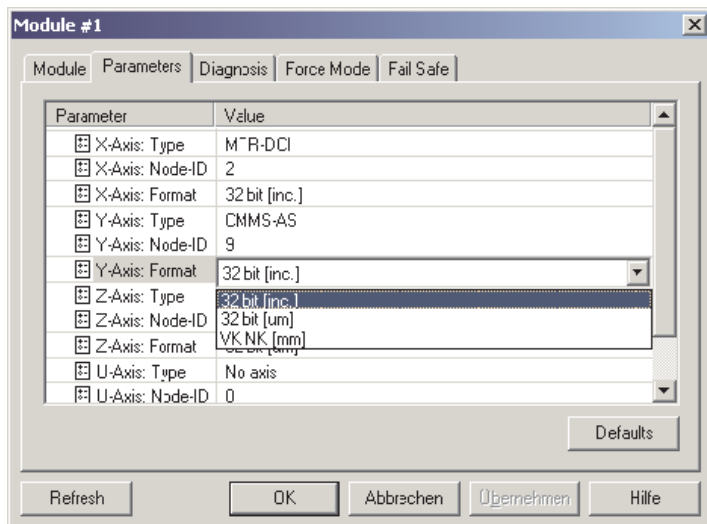

Fig. 3/5: Configuration with FMT: Format selection

3.7 Force

Through forcing, you can compel input and output signals. Actual input signals or changes in status by program are ignored and replaced by the force values.



Warning

High forces of acceleration at the connected actuators! Uncontrolled movements of the actuators can cause collisions and severe injuries.

- Be very careful when forcing in order to avoid uncontrolled movements of the actuators.
- Make sure that no persons are in the sphere of influence of the drives or any other connected actuators.

The following options are available for forcing:

- Handheld type CPX-MMI
- Front end controller
- Higher-order controller

Whether forcing is already possible after the system start can be set via the CPX terminal.



Further information on forcing can be found in the CPX system description, type P.BE-CPX-SYS-...

3. Commissioning

Diagnosis and error treatment

Chapter 4

Contents

4.	Diagnosis and error treatment	4-1
4.1	Summary of diagnostics options	4-3
4.2	Errors and warnings	4-4
4.2.1	Behaviour in case of errors and warnings	4-4
4.2.2	Acknowledging errors	4-4
4.2.3	Error numbers	4-5
4.3	Diagnosis via display	4-11
4.4	Diagnosis via LEDs	4-13
4.5	Diagnosis at the CPX terminal	4-15
4.5.1	Status bits in the system status of the CPX terminal	4-15
4.5.2	I/O diagnostic interface and diagnostics memory	4-16
4.5.3	Definition of diagnostics channels	4-19

4. Diagnosis and error treatment

4.1 Summary of diagnostics options

The CPX-CM-HPP supports various diagnostic and error handling options in the CPX terminal. An overview shows Tab. 4/1.

Diagnostics option	Brief description	Advantages	Detailed description
Error messages	The CPX-CM-HPP reports specific malfunctions of the connected drives as error messages (error groups) to the CPX master.	The error messages can be evaluated via the CPX fieldbus node or CPX-FEC/CPX-CEC or CPX-MMI.	See chapter 4.2 and CPX system description
Diagnostics with handheld type CPX-MMI	Diagnostic information can be shown on the CPX-MMI in a convenient and menu-driven manner.	Fast “on-site” error detection.	See chapter A.3 and description of handheld CPX-MMI.
Diagnostics with the display on the CPX-CM-HPP	The display on the CPX-CM-HPP alternately displays the status information and the error number of a current malfunction (error or warning) of the individual axes.	Fast “on-site” error detection.	See chapter 4.3
LED display	The LED Error displays error conditions directly.	Fast “on-the-spot” recognition of errors	See chapter 4.4
Status bits, I/O diagnostics interface and specific diagnostic functions	The errors recognised by the CPX-CM-HPP are reported in some cases to the CPX fieldbus node or CPX-FEC/CPX-CEC with specific additional information.	Fast access to error messages via the fieldbus, etc.	See CPX system description and descriptions of the respective CPX modules.

Tab. 4/1: Diagnostics options



Note

The available diagnostic information depends on the settings of the CPX fieldbus node or the CPX-FEC/CPX-CEC.

4.2 Errors and warnings

The CPX-CM-HPP supports a detailed error handling and evaluation. A list of errors is provided in section 4.2.3.

4.2.1 Behaviour in case of errors and warnings

A malfunction is reported to the CPX-CM-HPP as an error or warning message, depending on the parametrisation of the motor controller.



Warning

If an error occurs, only the axis involved stops. All other axes continue the movement. Undesired movements of the actuators can thus cause collisions and severe injuries.

- Make sure that no persons are in the sphere of influence of the drives or any other connected actuators.
- If necessary, program the higher-level PLC so that the other axes are automatically locked in the case of an error.

If a warning occurs, the drive involved can continue, depending on the selected setting. Warnings are sometimes displayed only for a certain time period.

4.2.2 Acknowledging errors

You have the following options to delete the error:

- Acknowledge the error with CCON.Reset.
- Acknowledge the error with the CPX-MMI.
- Switch the operating voltage off and then on again.

4. Diagnosis and error treatment

4.2.3 Error numbers

In the CPX terminal, error messages are summarised into error groups. You can find an overview of the error messages of the CPX-CM-HPP in Tab. 4/2.

On the handheld type CPX-MMI, the error group of the individual drives is displayed in the Diagnostics menu. If an axis is selected, the fault signal of this axis is displayed in plain text.

Since it can sometimes be defined in the drives whether a status is a warning or an error, the status type of the message in the CPX terminal cannot be uniquely specified. The error numbers of the subsequent table can therefore be for both errors and warnings.

The CPX-CM-HPP offers a 3-step error diagnosis:

1. The CPX-CM-HPP reports the error group no. to the CPX master (error group no. 100 ... 109).
2. The precise error below the error group is displayed on the 7-segment display of the CPX-CM-HPP and can be read out with the CPX-MMI.
3. Additional diagnostics options are then possible via the displayed error messages directly at the motor controller.



Further instructions can be found in the descriptions of the respective motor controller.



The possible error causes named in the following table do not claim to be complete. If in doubt, contact your local Festo Service.

4. Diagnosis and error treatment

Error no.	Designation and possible cause	Error handling
Configuration error (CPX error category 100)		
1	CAN communication error. <ul style="list-style-type: none"> – The drive's logic voltage is not switched on. – Cable defective. – Incorrect communication settings (profile: FHPP, Node-ID, baud rate). – Terminating resistors missing. 	<ul style="list-style-type: none"> • Switch on the drive's logic voltage • Exchange cable • Correct settings • Attach terminating resistors
2	Wrong axis type in configuration	<ul style="list-style-type: none"> • Correct axis type
3	FHPP Protocol ist not active	<ul style="list-style-type: none"> • Correct communication profile
Execution error (CPX error category 101)		
10	Please enforce homing run	<ul style="list-style-type: none"> • Execute homing
11	Error at start of homing run <ul style="list-style-type: none"> – Drive-internal error. 	<ul style="list-style-type: none"> • Contact Festo
12	Error during homing run <ul style="list-style-type: none"> – Enable signal not set. 	<ul style="list-style-type: none"> • Check trigger signals for homing. • Check controller parameters
13	SW limit switch <ul style="list-style-type: none"> – Internal software limit of the end position reached. 	<ul style="list-style-type: none"> • Check set software end positions
14	Limit switch: Negative setpoint inhibited <ul style="list-style-type: none"> – Neg. proximity switch actuated. 	<ul style="list-style-type: none"> • Check neg. proximity switch
15	Limit switch: Negative setpoint inhibited <ul style="list-style-type: none"> – Pos. proximity switch actuated. 	<ul style="list-style-type: none"> • Check pos. proximity switch
16	Positioning error <ul style="list-style-type: none"> – Following limit reached – Controller parameters not correct. 	<ul style="list-style-type: none"> • Check controller parameters • Correct controller parameters

4. Diagnosis and error treatment

Error no.	Designation and possible cause	Error handling
Position record error (CPX error category 102)		
20	Unknown command in record – Invalid entry in drive's record table	<ul style="list-style-type: none"> • Correct entry
21	Illegal record – Selection of a record number that is not on hand in the drive's record table	<ul style="list-style-type: none"> • Select another record
22	Parameter error in record (acceleration) – Invalid values in the drive's record table	<ul style="list-style-type: none"> • Correct values
23	Jump target error in record – Jump to a record that is not in the drive's record table	<ul style="list-style-type: none"> • Correct the jump destination
24	Missing user position data sets – Selection of a record without content in the drive's record table	<ul style="list-style-type: none"> • Create position data record or select another record
Controller error (CPX error category 103)		
30	General arithmetic error (in FHPP factor) – Internal error of the motor controller	<ul style="list-style-type: none"> • Contact Festo
31	Max. following error exceeded – Following error due to too much load – Incorrect settings of the drive parameters (speed, acceleration, delay)	<ul style="list-style-type: none"> • Check controller parameters • Correct settings
32	Operating mode error – Incorrect setting of the operating mode in the FHPP profile	<ul style="list-style-type: none"> • Correct setting
33	Standstill warning – Axis is not at standstill	<ul style="list-style-type: none"> • Check controller parameters
34	Time out of quick stop – Axis could not brake in the specified time	<ul style="list-style-type: none"> • Check controller parameters

4. Diagnosis and error treatment

Error no.	Designation and possible cause	Error handling
System error_A software, communication (CPX error category 104)		
40	CAN bus: Communication error – Internal error of the drive	• Contact Festo
41	Stack overflow – Internal error of the drive	• Contact Festo
42	Initialization error, Unexpected state – Internal error of the drive	• Contact Festo
43	Error current measurement U, V – Internal error of the drive	• Contact Festo
44	Node Guarding or Heart Beat – Internal error of the drive	• Contact Festo
45	RS232 communication error – Internal error of the drive	• Contact Festo
46	Internal calculation error – Internal error of the drive	• Contact Festo
47	IRQ overflow – Internal error of the drive	• Contact Festo
System error B hardware (CPX error category 105)		
50	Overvoltage of DC-bus – Internal error of the drive	• Contact Festo
51	Undervoltage of DC-bus – Internal error of the drive	• Contact Festo
52	Internal undervoltage supply – Internal error of the drive	• Contact Festo
53	SD error – Internal error of the drive	• Contact Festo
54	HW component error – Internal error of the drive	• Contact Festo

4. Diagnosis and error treatment

Error no.	Designation and possible cause	Error handling
55	Checksum error – Internal error of the drive	<ul style="list-style-type: none"> • Contact Festo
56	Flash error – Internal error of the drive	<ul style="list-style-type: none"> • Contact Festo
Error in the controller (CPX error category 107)		
70	Undervoltage logic power supply – Voltage lacking at the motor controller	<ul style="list-style-type: none"> • Check the power supply
71	I ² t Error (Overheating) – Too much load at the output of the controller	<ul style="list-style-type: none"> • Reduce the load. Check controller parameters.
72	Undervoltage or overcurrent of digital I/O – Internal error of the drive	<ul style="list-style-type: none"> • Contact Festo
73	Missing calibration data – Hardware fault at the motor controller – SD card defective	<ul style="list-style-type: none"> • Contact Festo
74	No user parameter set – Hardware fault at the motor controller – SD card defective	<ul style="list-style-type: none"> • Contact Festo
75	Hours-run meter missing – Hardware fault at the motor controller – SD card defective	<ul style="list-style-type: none"> • Contact Festo
Error in the measuring system (CPX error category 108)		
80	Angle encoder error – Encoder or resolver defective – Cable of the angle transducer defective – Hardware fault at the motor controller	<ul style="list-style-type: none"> • Check cable and replace if necessary • Contact Festo
81	Old encoder parameter set (type CMMP-AS) – Internal error of the drive	<ul style="list-style-type: none"> • Contact Festo
82	Index pulse warning	<ul style="list-style-type: none"> • Contact Festo

4. Diagnosis and error treatment

Error no.	Designation and possible cause	Error handling
Error in the motor or output stage (CPX error category 109)		
90	Motor stop – Internal error of the drive	• Contact Festo
91	Supply voltage error – Entrance bridge of the power supply defective – Intermediate circuit defective	• Contact Festo
92	Overtemperature of the power stage – Internal error of the drive	• Contact Festo
93	Overtemperature motor – Temperature sensor in the motor defective – Motor too hot	• Contact Festo
94	Short circuit in the power stage – Internal error of the drive	• Contact Festo
95	Motor temperature 5 °C below maximum – Internal error in the motor	• Contact Festo
96	I ² t Error (motor) – Internal error in the motor	• Contact Festo
99	General unassignable error – Other errors	• Contact Festo

Tab. 4/2: Error messages of the CPX-CM-HPP

4. Diagnosis and error treatment

4.3 Diagnosis via display

The status of the individual axes is displayed one after the other with the three-digit 7-segment display. In case of malfunctions, the error number or warning number is displayed; see section 4.2.3, page 4-5.

- 1 1st position
(e.g. code letter for parameters or status type)
- 2 Point for separation
- 3 2nd and 3rd position
(e.g. value, step or status information)

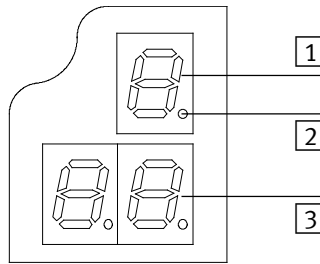

Fig. 4/6: Display/7-segment display

4. Diagnosis and error treatment

The following table describes the significance of the individual positions of the 7-segment display.



1 st position Axis no.	2 nd position Mode/ error no.	3 rd position Status/ error no.	Significance
1			Display of the status of the x-axis
2			Display of the status of the y-axis
3			Display of the status of the z-axis
4			Display of the status of the u-axis
	in Initialisation		Initialization display Connection set-up and initialization of the axes one after the other. Only when initialization of the current axis has been successfully completed will initialization of the next axis be started.
	S Record selection	0	Axis is switched on (Axis is READY)
		1	Controller enable (Axis is ENABLED)
		2	Axis is homed (Axis is REFERENCED)
	d Direct mode	0	Axis is switched on (Axis is READY)
		1	Controller enable (Axis is ENABLED)
		2	Axis is homed (Axis is REFERENCED)
	E Error		Error no.: 12 The display first shows “E” and then “12”.
	12		
	u Warning		Warning: 28 The display first shows “u” and then “28”.
28			

Tab. 4/3: Information on the three-digit 7-segment display

4. Diagnosis and error treatment



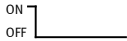

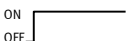

4.4 Diagnosis via LEDs

The following LEDs are available on the CPX-CM-HPP for diagnosing the CPX terminal.

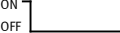
PL (Power Load) – load supply			
LED (yellow)	Sequence	Status	Error handling
 LED is off		Power supply failed	<ul style="list-style-type: none">• Make sure the voltage is applied
 LED illuminated		Power supply OK	–

Tab. 4/4: PL LED

4. Diagnosis and error treatment

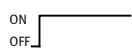
ERROR – error			
LED (red)	Sequence	Status	Error handling
 LED not illuminated		No error.	–
 LED flashes		CPX system error, CPX error category 3	See CPX System Description
		CPX-CMXX error, CPX error category 2	
		CPX system error, CPX error category 1	
		Software update (flash programming) active	
 LED lights up		1. CPX-CM-HPP is initialized. 2. Communication or drive error. The statuses of the axes are displayed in succession. Example 1: Only one axis is configured and is reporting an error. Result: The Error LED is illuminated continuously Example 2: Four axes are configured, but only one reports an error. Result: The Error LED is always illuminated when the status of the defective axis is shown on the display.	–

Tab. 4/5: ERROR LED

4.5 Diagnosis at the CPX terminal

Malfunctions of the connected axes are reported as CPX error group to the CPX master (CPX fieldbus node or CPX-FEC/CPX-CEC). One diagnostic channel is available for this per drive; see Tab. 4/9. The following sections include the special features of the representation for the CPX-specific diagnostics options.

- Status bits (see section 4.5.1)
- Diagnostics memory with CPX error groups (I/O diagnostics interface, see section 4.5.2)

4.5.1 Status bits in the system status of the CPX terminal

A CPX-CM-HPP error is always specified in the system status of the CPX terminal as follows:

Module type in which an error has occurred:

- Bit 0 ... 2 = 0
- Bit 3 = 1:

Error in analogue /function or technology module

Type of error

- Bit 4 ... 6 = 0
- Bit 7 = 1: Other error

Further instructions on the structure of the status bits can be found in the CPX system manual P.BE-CPX-SYS-...



4. Diagnosis and error treatment

4.5.2 I/O diagnostic interface and diagnostics memory

The CPX-CM-HPP reports the CPX error group to the CPX (CPX fieldbus node or CPX-FEC/CPX-CEC).

Diagnosis of the CPX error group can be made via the I/O diagnostics interface and the diagnostics memory of the CPX terminal.

Diagnostics memory data (I/O diagnostics interface)

The representation of diagnostics messages of the CPX-CM-HPP in the diagnostics memory of the CPX terminal takes place as shown in Tab. 4/6.

4. Diagnosis and error treatment

Diagnostic memory data (10 bytes per entry, max. 40 entries)				Function no. ¹⁾															
Byte no.	Designation	Description	Value	3488 + n															
1 ... 5	Days [day] Hours [h] Minutes [m] Seconds [s] Milliseconds [ms]	Time specification of the error reported, measured from the point when the power supply is switched on (CPX standard).	0 ... 255 0 ... 23 0 ... 59 0 ... 59 0 ... 99 (128 ... 227)	$n = 10 * d + 0$															
6	Module code	Module code of the CPX-CM-HPP: 175	0 ... 255	$n = 10 * d + 5$															
7	Module position [Pos]	Module number of the CPX module that reported the error.	0 ... 47	$n = 10 * d + 6$															
8	Channel number	<table border="1"> <thead> <tr> <th>Bit</th> <th>channel</th> <th>description</th> </tr> </thead> <tbody> <tr> <td>00</td> <td>I1</td> <td>X-axis</td> </tr> <tr> <td>01</td> <td>I2</td> <td>Y-axis</td> </tr> <tr> <td>10</td> <td>I3</td> <td>Z-axis</td> </tr> <tr> <td>11</td> <td>I4</td> <td>U-axis</td> </tr> </tbody> </table>	Bit	channel	description	00	I1	X-axis	01	I2	Y-axis	10	I3	Z-axis	11	I4	U-axis	0 ... 255	$n = 10 * d + 7$
Bit	channel	description																	
00	I1	X-axis																	
01	I2	Y-axis																	
10	I3	Z-axis																	
11	I4	U-axis																	
9	Error number [FN]	CPX error group (see section 4.2.3)	100 ... 109	$n = 10 * d + 8$															
10	Following channels	With CPX-CM-HPP always 0	0 ... 63	$n = 10 * d + 9$															
¹⁾ d (diagnostics event) [NB] = 0 ... 39 ; most current diagnostics event = 0																			

Tab. 4/6: Diagnostics memory data of the CPX-CM-HPP



Instructions on diagnostics with the I/O diagnostics interface can be found in the CPX System Description.

4. Diagnosis and error treatment

Diagnostics data of the module (I/O diagnostics interface)

The specific representation of module diagnostics data (error messages) of the CPX-CM-HPP takes place as shown in Tab. 4/7 and Tab. 4/8.

Module diagnostics data: Location where error arose																
Function no.	$2008 + m * 4 + 0$; m = module number (0 ... 47)															
Description	Describes where the corresponding error occurred.															
Bit	Bits 0 ... 7 Location where error arose <table border="1"> <thead> <tr> <th>Bit</th> <th>channel</th> <th>description</th> </tr> </thead> <tbody> <tr> <td>00</td> <td>I1</td> <td>X-axis</td> </tr> <tr> <td>01</td> <td>I2</td> <td>Y-axis</td> </tr> <tr> <td>10</td> <td>I3</td> <td>Z-axis</td> </tr> <tr> <td>11</td> <td>I4</td> <td>U-axis</td> </tr> </tbody> </table>	Bit	channel	description	00	I1	X-axis	01	I2	Y-axis	10	I3	Z-axis	11	I4	U-axis
Bit	channel	description														
00	I1	X-axis														
01	I2	Y-axis														
10	I3	Z-axis														
11	I4	U-axis														

Tab. 4/7: Location where error arose

Module diagnostics data: Module error number	
Function no.	$2008 + m * 4 + 1$; m = module number (0 ... 47)
Description	CPX error category (see chapter 4.2.3)
Bit	Bits 0 ... 7 Range of values: 100 ... 109

Tab. 4/8: Module error number

4. Diagnosis and error treatment

4.5.3 Definition of diagnostics channels

To implement the axis-specific diagnostics, four input channels are defined as diagnostics channels. The individual diagnostics channels report errors of the respective axis.

The following table shows the definition of the diagnostics channels

	Channel number	Axis
Input channel	1	1
	2	2
	3	3
	4	4

Tab. 4/9: Definition of diagnosis channels

4. Diagnosis and error treatment

Technical appendix

Appendix A

Contents

C.	Technical appendix	A-1
A.1	Technical Data	A-3
A.2	Accessories	A-4
A.3	Device-specific information on the CPX-MMI handheld	A-5

A.1 Technical Data

Type	CPX-CM-HPP
General technical data of the CPX terminal	See CPX System Description – P.BE-CPX-SYS-...
Total number of axes	Max 4 axes per CPX-CM-HPP
Device-specific diagnostics	– Channel and module-oriented diagnostics – Undervoltage/short-circuit modules – Diagnostics memory
Configuration support	CPX-MMI
LED indicator	PL: Power supply Error Error
Axis connection – Protocol – Baud rate – Fieldbus interface – Max. line length	CAN bus FHPP 1 Mbit/s Socket, M9, 5-pin 30 m
CPX module code	175
Max. address capacity – Inputs – Outputs	32 byte 32 byte
Protection class as per IP 60529, plug connector inserted	IP65
Nominal operating voltage	24 VDC
Operating voltage range	18 ... 30 V DC
Intrinsic current consumption – at rated operating voltage	typ. 80 mA
Power failure buffering	10 ms
Product weight (without interlinking block)	approx. 140 g
Dimensions W x L x H	50 mm x 107 mm x 55 mm

A.2 Accessories



Accessories for the CPX-CM-HPP can be found in our catalogue under www.festo.com/catalogue.

A.3 Device-specific information on the CPX-MMI handheld

Some information of the CPX-CM-HPP is represented on the CPX-MMI. This information is explained subsequently by means of some examples.

System Overview		
CPX terminal		
0: FEC Controller		
1: CM-HPP FHPP-Gateway		
2: 8DI/8DO Multi I/O		
Diag	←→	OK

The CPX-CM-HPP is displayed as “CM-HPP FHPP-Gateway” module on the MMI. The complete name is displayed with the key “←→”.

The module-related menu options and functions are explained subsequently. Further below, you will find information about the system diagnosis that you can call up under [Diag].

1: CM-HPP	
Monitoring/Forcing (M)	
Diagnostics (D)	
Parameters (P)	
Module Data (MD)	
Back	OK

The CPX-CM-HPP supports the following functions:

- Monitoring/Forcing (M)
- Diagnostics (D)
- Parameters (P)
- Module Data (MD)



Warning

Incorrect entries in the Force Mode, [Monitoring/Forcing (M)] menu can cause accidental movements and severe personal injury and material damage!

A. Technical appendix

<u>1: CM-HPP</u>	
X-Axis: MTR-DCI	
Y-Axis: CMMS-AS	
Z-Axis: No axis	
U-Axis: No axis	
Back	OK

In the [Monitoring/Forcing (M)] menu, the current values of some inputs and outputs of the connected motor controllers are displayed. With the “Force Mode” function, statuses of the inputs and outputs can be forced.

<u>1: CM-HPP:M.X</u>	
Process state	
I: Enabled	
I: Open	
I: Warn	
I: Fault	
I: 24VL	
I: Lock	
I: OPM1	
I: OPM2	
I: /Halt	
I: MC	
I: Ref	
O: Enable	
O: /Stop	
O: /Brake	
O: Reset	
O: Lock	
O: OPM1	
O: OPM 2	
O: /Halt	
Back	Force Mode

The following I/O data are displayed for each axis:

Entry in the CPX-MMI	FHPP bit
I: Enabled	SCON.B0
I: Open	SCON.B1
I: Warn	SCON.B2
I: Fault	SCON.B3
I: 24VL	SCON.B4
I: Lock	SCON.B5
I: OPM1	SCON.B6
I: OPM2	SCON.B7
O: Enable	CCON.B0
O: /Stop	CCON.B1
O: /Brake	CCON.B2
O: Reset	CCON.B3
O: Lock	CCON.B5
O: OPM1	CCON.B6
O: OPM2	CCON.B7
O: /Halt	CPOS.B0



Note

The status changes are not constantly updated. Allocation of the individual bits conforms to the FHPP profile. Please observe the drive-specific allocation (see e.g. description P.BE-CMM-FHPP-SW-DE)

With the [Force Mode] function, you change to the [Force Mode] menu. The first time it is called up, you receive the following warning:

“Warning: If you modify settings, dangerous movements of the actuators are possible.”

This is how you activate the write authorization for the Handheld CPX-MMI: Menu [Modify] function “Handheld write access” enable/disable.

- Select “Enable”

The following warning is displayed:

”Warning: Your choice will disable host write access. Are you sure?”

- Confirm with “Ok” to change to the [Force Mode] menu.

<u>1: CM-HPP :M.Y</u>		
Drive Control (C)		
Exex Record (E)		
Jog / Ref / Teach (J)		
Back	Mode	OK

The following functions are available in the [Force Mode] menu:

- Drive Control (C)
- Exec Record (E)
- Jog / Ref / Teach (J)
- Mode

The following functions are available in the [Mode] menu:

- Clear force settings actual module/all modules
- Force Mode (Sys.par.) enable / disable

A. Technical appendix

<u>1: CM-HPP :M.Y.C</u>	
Sys: Force Mode enabled	
State	
Enable	
/Stop	
Reset	
/Halt	
Lock	
OPM1	
OPM2	
Back	Set

In the [Drive Control (C)] menu, the following commands can be set:

Entry in the CPX-MMI	FHPP bit
Enable	CCON.B0
/Stop	CCON.B1
Reset	CCON.B3
/Halt	CPOS.B0
Lock	CCON.B5
OPM1	CCON.B6
OPM2	CCON.B7

<u>1: CM-HPP :M.Y.E</u>	
Sys: Force Mode enabled	
Record no.	0
	Set
Start	
/Stop	
/Halt	
Clear	
	State
MC	
Warn	
Fault	
Back	Set

In the [Exec Record (E)] menu, a positioning record can be selected and started. In addition, the following commands and status information are available:

Entry in the CPX-MMI	FHPP bit
Start	CPOS.B1
/Stop	CCON.B1
/Halt	CPOS.B0
Clear	CPOS.B6
MC	SPOS.B2
Warn	SCON.B2
Fault	SCON.B3

A. Technical appendix

1: CM-HPP :M.Y.J	
Sys: Force Mode enabled	
Set	
0	Home
0	Jog neg
0	Jog pos
0	/Teach
	State
MC	0
Ref	0
Warn	0
Fault	0
Teach Ack	0
Back	Set

You can execute the following functions in the [Jog / Ref / Teach (J)] menu. Some status information is also available:

Entry in the CPX-MMI	FHPP bit
Home	CPOS.B2
Jog neg	CPOS.B4
Jog pos	CPOS.B3
/Teach	CPOS.B5
MC	SPOS.B2
Ref	SPOS.B7
Warn	SCON.B2
Fault	SCON.B3
Teach Ack	SPOS.B3

1: CM-HPP :D	
Diagnostics	
X-Axis: 104-System error A	
Y-Axis: No error	
Z-Axis: No error	
U-Axis: No error	
Back	↔ Detail

The CPX error groups of the axes are displayed in the [Diagnostics (D)] menu.

1: CM-HPP :D.X	
Fault X-Axis: 104-44	
44- Node Guarding or Heart Beat	
Back	Res fault

The CPX error group, error number and error text of the selected axis are displayed in the [Detail] menu.

The description of this is found in section 4.2.3.

A. Technical appendix

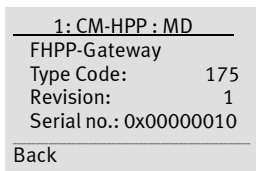

In the [Module Data (MD)] menu, the following information is displayed by the CPX-CM-HPP (example).

- Module designation: FHPP-Gateway
- Module type: 175
- Revision: 1
- Serial number 0x00000010

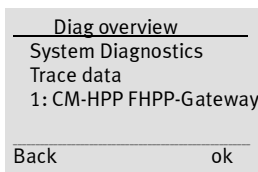

System diagnostics functions are available in the [Diag] menu.

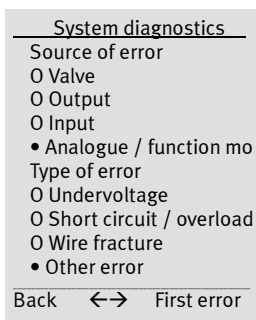

The CPX status bits are displayed in the [System diagnostics] menu.

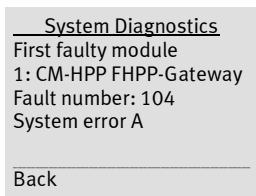

The [First Error] menu displays the following additional information on the current error.

- Module position and designation
- Number of the CPX error group
- Designation of the CPX error group

A. Technical appendix

Trace data
NB-FN-Pos-Day-h-m-s-ms
√ 0 107 1 000:0:2:57:13

Back ←→ Detail

The error memory is displayed in the [Trace Data] menu.

- Number of the entry (NB)
- Number of the CPX error group (FN)
- Module position (Pos)
- Time stamp in the format Days:Hours:Minutes: Seconds:Milliseconds (Day-h-m-s-ms) since the CPX terminal was switched on

Trace data number 0
In fault Ch 1
System error A
Module position 1
CM-HPP: FHPP-Gateway
Days: 0
Hours: 0
Minutes: 2
Seconds: 57
Milliseconds: 13

Back ←→

The [Detail] menu displays the following additional information on the current error.

- Channel number
- Designation of the CPX error group
- Module position
- Module designation
- Time stamp in the format Days:Hours:Minutes: Seconds: Milliseconds (Days:Hours:Minutes:Seconds: Milliseconds) since switch-on



Note

Additional information on the Handheld CPX-MMI can be found in the documentation P.BE-CPX-MMI-1-...

A. Technical appendix

Index

Appendix B

B. Index

Contents

D.	Index	B-1
-----------	--------------------	------------

Numbers

0-Signal	XV
1-Signal	XV

A

Abbreviations, Product-specific	XV
Acknowledging errors	4-4
Axis connection	XV

C

CAN bus	
Connecting	2-7
Line	2-7
CAN bus interface	2-6
Connection and display components	1-9

D

Diagnostics	
CPX Terminal	4-15
Diagnostics channels	4-19
Diagnostics memory	4-16
Display	4-11
I/O diagnostics interface	4-16, 4-18
LEDs	4-13
Status bits	4-15
Summary of diagnostics options	4-3
Dismantling	2-4

E

Errors and warnings	
Acknowledge error	4-4
Behaviour	4-4
Error numbers	4-5
Overview	4-4

F

FHPP	3-4
------------	-----

H

Handheld CPX-MMI	A-5
------------------------	-----

I

Important user instructions	IX
Installation	2-3, 3-3
Instructions on the description	XIII
Intended use	VII

M

Module diagnostics data	
Module error number	4-18
Number of the first defective channel	4-18
Mounting	2-4

P

Pictograms	X
------------------	---

S

Safety instructions	XI
Service	VIII
Strain relief	2-7

T

Target group	VIII
Technical Data	A-3
Text markings	X

B. Index