

Linear/swivel clamps CLR-CS

FESTO

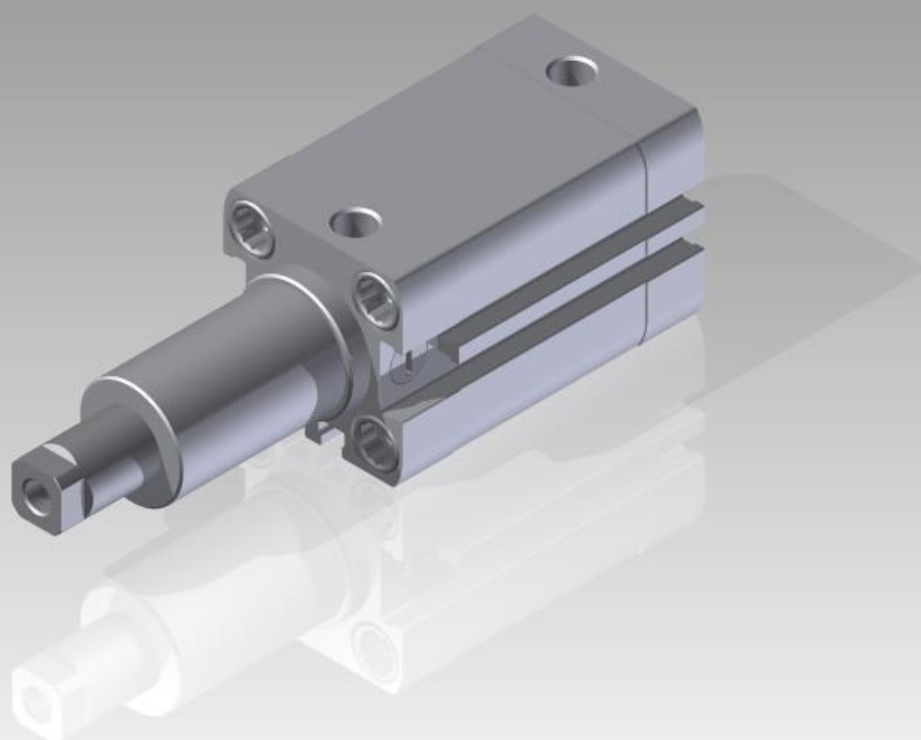

Key features

Functional description

The linear/swivel clamp CLR-CS is used for all types of clamping. Through the combination of the linear and swivel motion of the piston rod, workpieces can be inserted and removed even beyond the clamping range. There is a choice between swivelling to the right or left, while the CLR-CS also boasts a linear stroke for diameters of 40 and above.

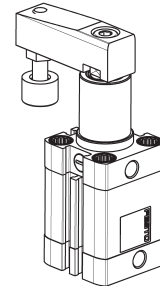

Optimal range

- Uncomplicated mechanical system
- Sturdy design
- Long service life
- Low procurement, assembly and maintenance costs

Easy to mount

- The hole pattern corresponds to ISO 21287, meaning that foot and flange mountings from the standard accessories range can be used
- Female threads in the bearing and end caps make it easy to assemble the cylinder either directly or using mounting accessories

Practical

- Clamping finger including plug-on rubber cap to protect sensitive surfaces
- Clamping finger can be freely adjusted each 90°
- Can be repaired using set of wearing parts
- Corresponding accessories such as tubing, flow control valves and push-in fittings

Swivel direction

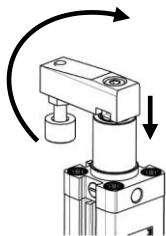

Swivelling to the right

View from above of the piston rod side

with the piston rod retracted.

Clockwise swivel direction.

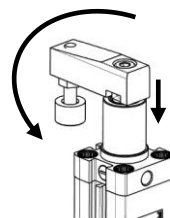

Swivelling to the left

View from above of the piston rod side

with the piston rod retracted.

Anticlockwise swivel direction

Type code	
001	Series
CLR	Linear swivel clamp, double-acting
002	Piston diameter
25	25
32	32
003	Stroke
10	10
20	20
004	Swivel direction
R	Right
L	Left
005	Cushioning
P	Elastic cushioning rings/plates on both sides
006	Position sensing
A	For proximity sensor
007	Version
CS	CM project

General technical data			
Piston \varnothing	25	32	
Pneumatic connection	M5	G1/8	
Piston rod thread	M6	M8	
Clamping stroke ¹⁾	[mm]	10	20
Total stroke ²⁾	[mm]	20	30
Swivel direction	Right, left	10	20
Swivel angle	[°]	90±4	25
Operating medium	Compressed air to ISO 8573-1:2010 [7:4:4]	35	
Note on operating/ pilot medium	Lubricated operation possible (in which case lubricated operation will always be required)		
Design	Piston		
	Piston rod		
	Cylinder barrel		
Cushioning	Elastic cushioning rings/plates at both ends		
Position sensing	Via proximity switch		
Type of mounting	With through-hole		
	With female thread		
	Via accessories		
Mounting position	Any		
Clamping range	≥ 2 mm before the end position is reached		

1) The clamping stroke corresponds to the linear stroke used for clamping

2) The total stroke comprises the clamping stroke and the swivel stroke

Operating and environmental conditions		
Operating pressure	[MPa]	0.2 ... 1
Ambient temperature ¹⁾	[°C]	-10 ... +80
Corrosion resistance class		CRC 0 (according to Festo FN 940070)

1) Note operating range of proximity switches

Weight [g]			
Piston \varnothing		25	32
Product weight at stroke	10 mm	254	431
	20 mm	293.5	485.5

Working frequency [Hz]			
Piston \varnothing		25	32
Frequency at stroke	10 mm	2.5	2.5
	20 mm	1.7	1.7

Forces [N] without clamping finger		
Piston \varnothing	25	32
Theoretical clamping force at 0.6 MPa	227	362

Forces [N] with clamping finger ¹⁾²⁾			
Piston \varnothing		25	32
Effective clamping force at	0.2 MPa	63	111
	0.4 MPa	127	216
	0.6 MPa	188	313

1) Clamping finger is not a standard parts; for its material and outfit dimensions, please refer to standard product CLR-20/25-FS, CLR-32/40-FS

2) Forces measured where 5mm before end of stroke

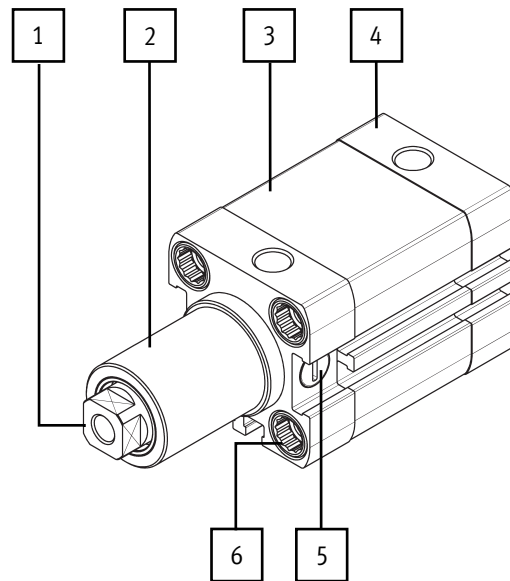

Material of components		
1	Piston rod	Heat-treated tool steel
2	Bearing cap	Anodised aluminium
3	Cylinder barrel	Anodised aluminium
4	End cap	Anodised aluminium
5	Guide pin	Surface-treated tool steel
6	Flange screws	Galvanised steel
-	Seals	Polyurethane
-	Note on materials	RoHS-complaint

Maximum permissible mass moment of inertia J_0

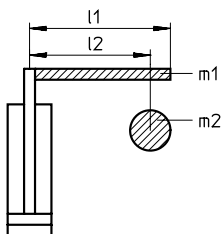

m_1 = mass of the clamping finger
 l_1 = length of the clamping finger
 m_2 = mass of the screw
 l_2 = centre distance between screw and piston rod

Note:

The permissible mass moment of inertia at the piston rod depends on the cylinder's speed. The moment can easily be calculated using this formula. The software program "mass moments of inertia", available on the our website, can also be used for calculation purposes.

Maximum permissible mass moment of inertia:

$$J_0 = \frac{m_1 \cdot l_1^2}{3} + m_2 \cdot l_2^2$$

Mass moment of inertia J as a function of the time t required for a single stroke

∅ 25

∅ 32

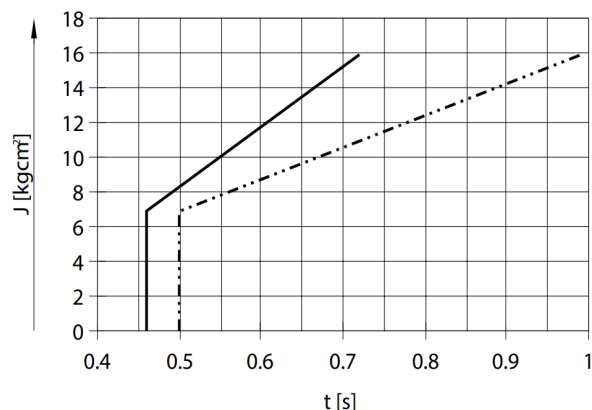
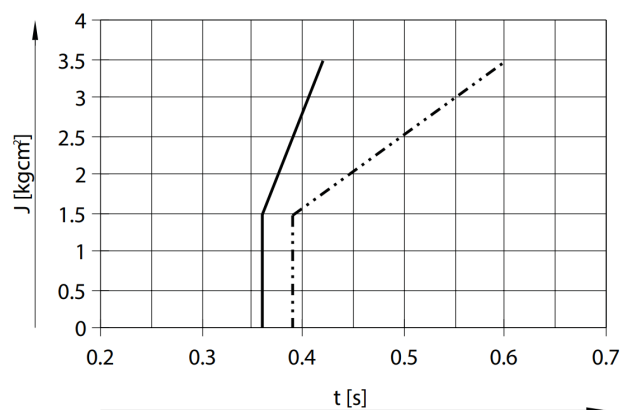

——— 10 mm stroke
 - - - - - 20 mm stroke

Assembling a clamping finger

Step 1

- Place the clamping finger on the slot of the piston rod
- Screw the retaining screw into the threaded hole of the piston rod until the clamping finger can still be turned

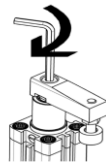

Step 2

- Hold the clamping finger in the place at the spanner flat using an open-ended spanner
- Tighten the retaining screw using the tightening torque below

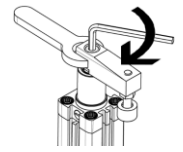

Tightening torques [Nm]		
Piston \varnothing	25	32
Max. tightening torque clamping finger screw	12	24

Note:

Holding the clamping finger instead of cylinder body when tightening, or else, too much force on piston rod will damage the internal mechanism.

Maximum permissible clamping arm length l as a function of the operating pressure p

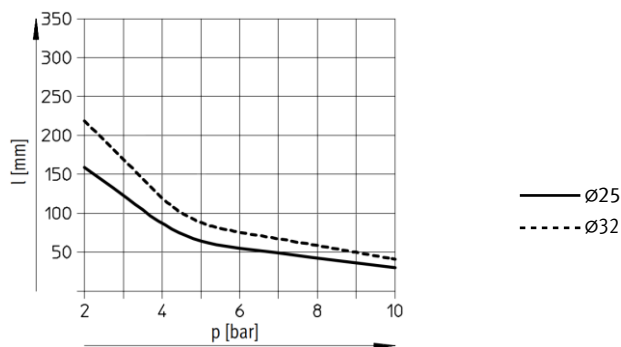

Note:

When manufacturing the clamping finger in-house, the following values must be checked and calculations performed.

Dimensions

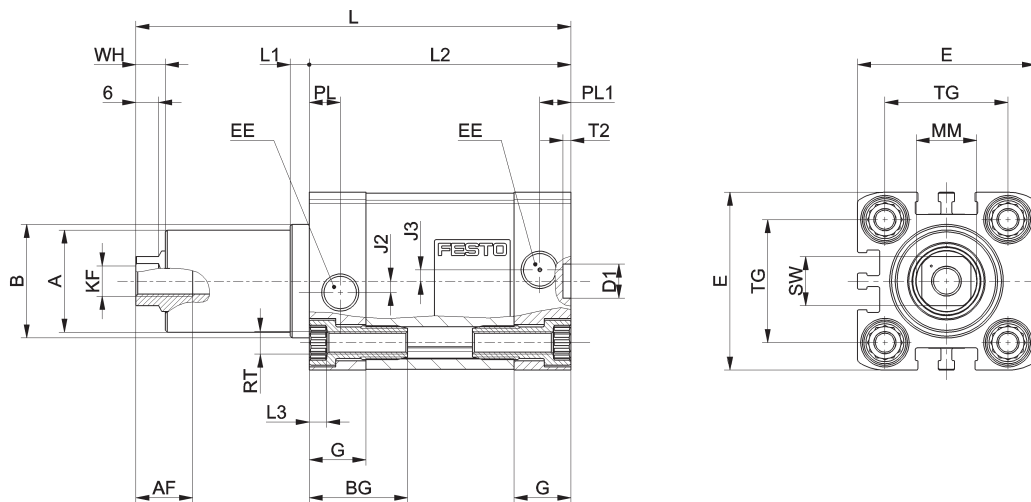

Type	E +0.3	TG	SW H13	KF	AF Min.	$\varnothing A$	$\varnothing MM$	L3	RT	BG Min.	PL	PL1
CLR-25-10-	39.5	26	10	M6	15	21	12	4.6	M5	19.5	6	6
CLR-25-20-	39.5	26	10	M6	15	21	12	4.6	M5	19.5	6	6
CLR-32-10-	47	32.5	13	M8	15	27	16	4.6	M6	26	8.2	8.2
CLR-32-20-	47	32.5	13	M8	15	27	16	4.6	M6	26	8.2	8.2

Type	L1	$\varnothing B$ h9	WH	EE	L2 ± 0.3	L(in) ± 1.5	L(out) ± 1.5	G	J2	J3	$\varnothing D1$ h9	T2 +0.1
CLR-25-10-	5	23	6.2	M5	59	98	118	12	0	0	9	1.8
CLR-25-20-	5	23	6.2	M5	69	118	148	12	0	0	9	1.8
CLR-32-10-	5	30	7.8	G1/8	69	115	140	15	3	3	9	2.1
CLR-32-20-	5	30	7.8	G1/8	79	135	170	15	3	3	9	2.1

Linear/swivel clamps CLR-CS

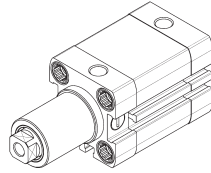

Ordering data		
Part No.	Part number	Type
	8187877	CLR-25-10-L-P-A-CS
	8187878	CLR-25-20-L-P-A-CS
	8187879	CLR-25-10-R-P-A-CS
	8187880	CLR-25-20-R-P-A-CS
	8187881	CLR-32-10-L-P-A-CS
	8187882	CLR-32-20-L-P-A-CS
	8187883	CLR-32-10-R-P-A-CS
8187884	CLR-32-20-R-P-A-CS	
Function	Double - acting	

Accessories

Foot mounting HNA

Material:
Galvanised steel
Free of copper and PTFE
RoHS-compliant

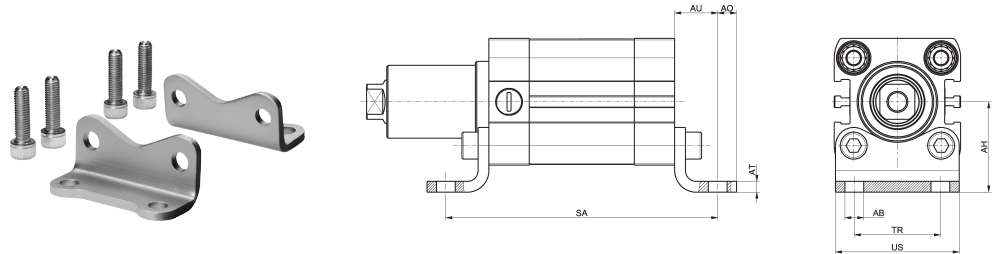

Type	∅AB H14	AH JS4	AO	AT	AU	SA	TR	US	Weight [g]	Part no.	Type
CLR-25-10-	7	29	6.25	4	16	91	26	38.5	90	537240	HNA-25
CLR-25-20-						101					
CLR-32-10-	7	33.5	7	4	16	101	32	46	123	537241	HNA-32
CLR-32-20-						111					



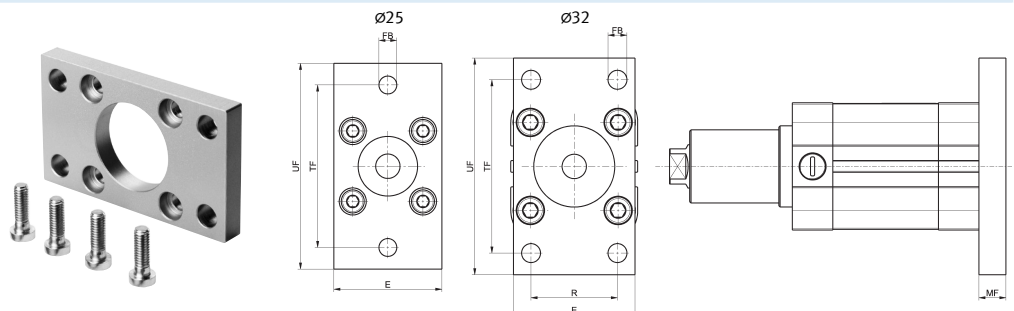

Foot mounting FNC

Material:
Galvanised steel
Free of copper and PTFE
RoHS-compliant



Type	E	∅FB H13	MF	R	TF	UF	Weight [g]	Part no.	Type
CLR-25-	40	6.60	8	-	60	76	165	537248	FNC-25
CLR-32-	45	7	10	32	64	80	221	174376	FNC-32



Accessories

Ordering data – One-way flow control valves					
	Connection Thread	For tubing O.D. [mm]	Material	Part no.	Type
For exhaust air					
	M5	3	Metal design	193137	GRLA-M5-QS-3-D
		4		193138	GRLA-M5-QS-4-D
		6		193139	GRLA-M5-QS-6-D
	G1/8	3		193142	GRLA-1/8-QS-3-D
		4		193143	GRLA-1/8-QS-4-D
		6		193144	GRLA-1/8-QS-6-D
		8		193145	GRLA-1/8-QS-8-D
		For exhaust air			
	G1/8	4	Metal design	578797	VFOH-LE-A-G18-Q4
		6		578798	VFOH-LE-A-G18-Q6
		8		578799	VFOH-LE-A-G18-Q8
For exhaust air					
	G1/8	6	Metal design	162965	GRLA-1/8-QS-6-RS-B
		8		162966	GRLA-1/8-QS-8-RS-B
For supply air					
	M5	3	Metal design	193153	GRLZ-M5-QS-3-D
		4		193154	GRLZ-M5-QS-4-D
		6		193155	GRLZ-M5-QS-6-D
	G1/8	3		193156	GRLZ-1/8-QS-3-D
		4		193157	GRLZ-1/8-QS-4-D
		6		193158	GRLZ-1/8-QS-6-D
		8		193159	GRLZ-1/8-QS-8-D

Ordering data – One-way flow control valves					
	Connection Thread ¹⁾	For tubing I.D. [mm]	Material	Part no.	Type
For exhaust air					
	M5	3	Metal design	151161	GRLA-M5-PK-3-B
		4		151162	GRLA-M5-PK-4-B
		6		151166	GRLA-1/8-PK-3-B
	G1/8	3		151167	GRLA-1/8-PK-4-B
		4		151168	GRLA-1/8-PK-6-B
		6			

1) Union nut for barbed fitting only with screw-in thread G1/8

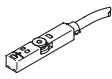
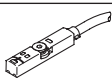
Accessories

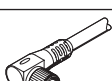
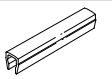
Ordering data – Proximity switch for T-slot, magneto-resistive						
	Type of mounting	Switching output	Electrical connection	Cable length [m]	Part no.	Type
N/O contact						
	Inserted in the slot from above, flush with the cylinder profile, short design	PNP	Cable, 3-wire	2.5	574335	SMT-8M-A-PS-24V-E-2.5-OE
			Plug M8x1, 3-pin	0.3	574334	SMT-8M-A-PS-24V-E-0.3-M8D
			Plug M12x1, 3-pin	0.3	574337	SMT-8M-A-PS-24V-E-0.3-M12
		NPN	Cable, 3-wire	2.5	574338	SMT-8M-A-NS-24V-E-2.5-OE
			Plug M8x1, 3-pin	0.3	574339	SMT-8M-A-NS-24V-E-0.3-M8D
N/C contact						
	Inserted in the slot from above, flush with the cylinder profile, short design	PNP	Cable, 3-wire	7.5	574340	SMT-8M-A-PO-24V-E-7.5-OE
Ordering data – Connecting cables						
	Electrical connection, left	Electrical connection, right	Cable length [m]	Part no.	Type	
	Straight socket, M8x1, 3-pin	Cable, open end, 3-wire	2.5	541333	NEBU-M8G3-K-2.5-LE3	
			5	541334	NEBU-M8G3-K-5-LE3	
	Straight socket, M12x1, 5-pin	Cable, open end, 3-wire	2.5	541363	NEBU-M12G5-K-2.5-LE3	
			5	541364	NEBU-M12G5-K-5-LE3	
	Angled socket, M8x1, 3-pin	Cable, open end, 3-wire	2.5	541338	NEBU-M8W3-K-2.5-LE3	
			5	541341	NEBU-M8W3-K-5-LE3	
	Angled socket, M12x1, 5-pin	Cable, open end, 3-wire	2.5	541367	NEBU-M12W5-K-2.5-LE3	
			5	541370	NEBU-M12W5-K-5-LE3	
Ordering data – Slot cover for T-slot						
	Mounting	Length [m]	Part no.	Type		
	Insertable	2x 0.5	151680	ABP-5-S		