

# FBS-SUB-9-GS-2X4POL-B

## Plug

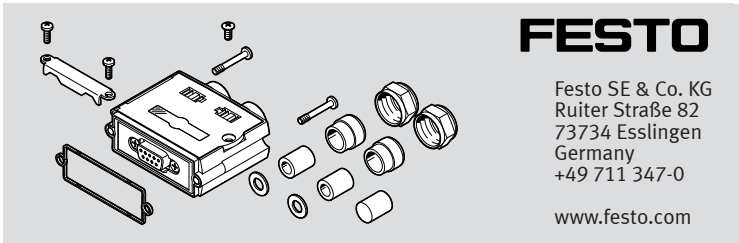

**FESTO**

Festo SE & Co. KG  
Rüter Straße 82  
73734 Esslingen  
Germany  
+49 711 347-0

www.festo.com

Assembly instructions

8183062  
2024-06b  
[8183064]



8183062

Original instructions

© 2024 all rights reserved to Festo SE & Co. KG

### 1 Applicable Documents

All available documents for the product → [www.festo.com/sp](http://www.festo.com/sp).

### 2 Safety

#### 2.1 Safety instructions

– Before working on the product: Switch off the power supply, ensure that it is off and secure it against being switched on again.

#### 2.2 Intended use

The plug connects bus nodes with CC-LINK interface and additional fieldbus stations.

### 3 Additional information

- Contact the regional Festo contact if you have technical problems → [www.festo.com](http://www.festo.com).
- Accessories → [www.festo.com/catalogue](http://www.festo.com/catalogue).

### 4 Product overview

#### 4.1 Scope of delivery

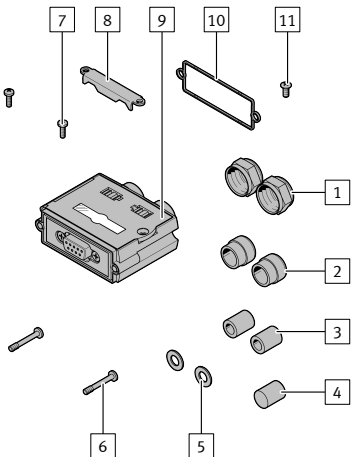

- 1 Union nut (2x)
- 2 External sealing ring (2x)
- 3 Internal sealing ring (2x) Open
- 4 Internal sealing ring (1x) Closed
- 5 Washer (2x)
- 6 Screw (2x)
- 7 Screw (2x) self-tapping
- 8 Clamping clip (1x)
- 9 Housing (1x) with SUB-D plug
- 10 Seal (1x)
- 11 Screw (1x) self-tapping

Fig.1

### 4.2 Contact assignment

SUB-D plug	Terminal	Signal
1	–	–
2	DA	DA
3	DG	DG
4	–	–
5	*NC*	–
6	–	–
7	DB	DB
8	–	–
9	–	–
Housing	Clamping clip	SLD/FG

Tab. 1: Contact assignment

### 5 Mounting

#### 5.1 Preparing assembly

For cables with diameter 5 ... < 6.5 mm

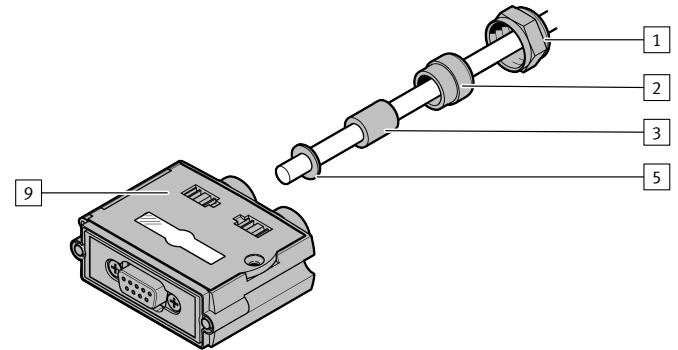

Fig.2

1. Slide components 1, 2, 3 and 5 onto the cable.
2. Insert the internal sealing ring 3 into the external sealing ring 2.

For cables with diameter 6.5 ... 10 mm

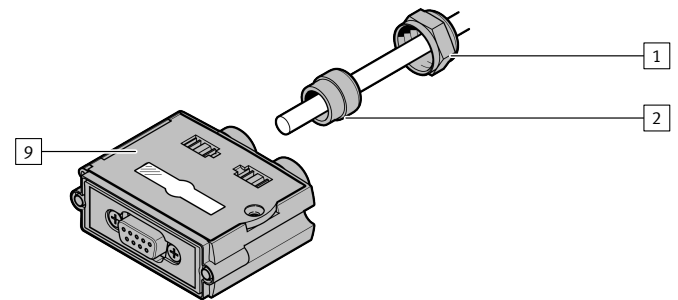

Fig.3

- Slide components 1 and 2 onto the cable.

#### 5.2 Wiring cables

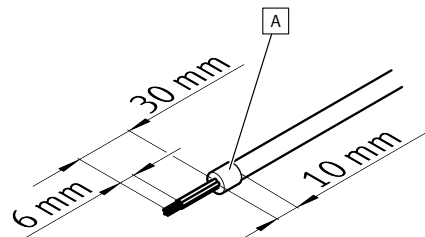

Fig.4

1. Strip the cable end.
2. Attach the braided screen (A) to the cable sheath.
3. Open the housing 9.
4. Run the cable through the housing 9.

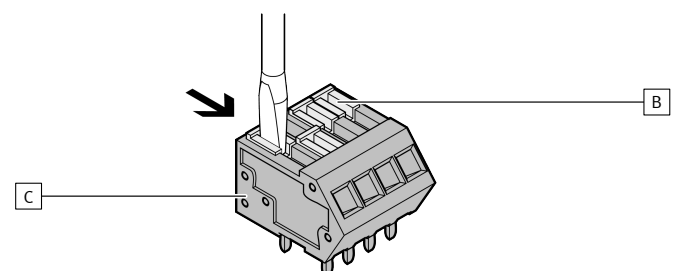

Fig.5

- Unlock all release sliders (B). Use a screwdriver with 2.5 x 0.4 mm.

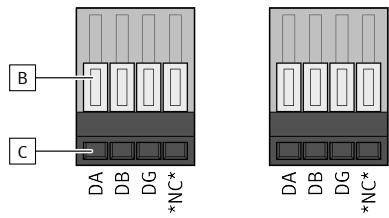

Fig.6

- Insert the wires into the terminal strip (C) in accordance with the contact assignment.

### 5.3 Mounting cables

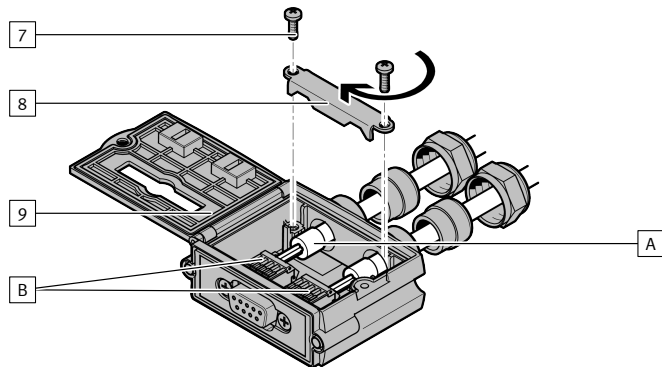

Fig.7

1. Use the clamping clip [8] to clamp the bare braided screen (A) to the contact surface of the circuit board.
2. Tighten the screws [7] alternately. When tightening again, use the threads already present. Tightening torque: 0.5 Nm ± 10%
3. Make sure that the wires are correctly seated in the terminal strip.
4. Lock all release sliders (B).

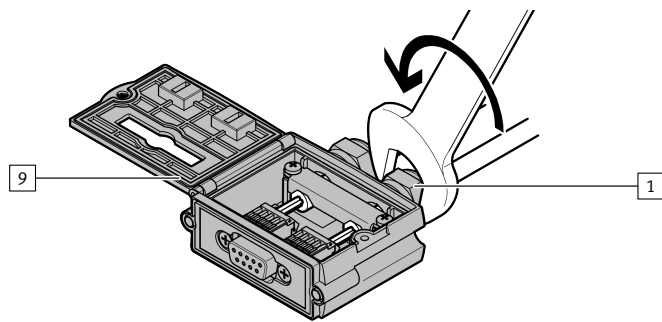

Fig.8

- Tighten the union nut [1].
  - $\approx 17$
  - Tightening torque: 0.5 Nm ± 10%

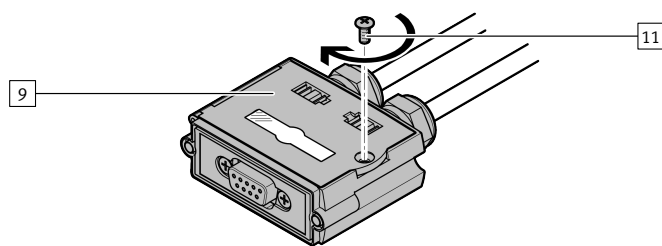

Fig.9

1. Close the housing [9].
2. Tighten the screw [11]. When tightening again, use the threads already present. Tightening torque: 0.5 Nm ± 10%

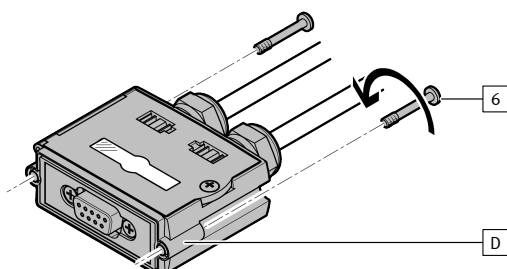

Fig.10

- Tighten the screws [6] firmly through the captive elements [D].

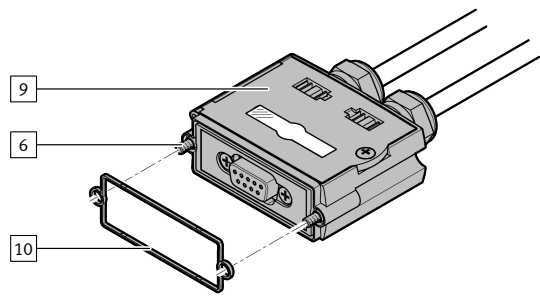

Fig.11

1. Place the seal [10] into the recess of the housing [9].
2. Fasten the plug with the screws [6]. Tightening torque: 0.5 Nm ± 10%